

ISSUE OF 6 PAGES

AIRPLANE CHARACTERISTICS & PERFORMANCE

BUREAU OF AERONAUTICS, NAVY DEPT.

COLUMN NUMBER		1	2	3	4
LOADING CONDITION		SCOUT	SCOUT	BOMBER 1-2000# BOMB 2-WING TANKS	BOMBER 1-2000# BOMB AN/APS-4
GROSS WEIGHT	LBS.	14236	14236	18360	16337
EMPTY WEIGHT (CALCULATED)	LBS.	10669			
FUEL/OIL	GALS.	390/22	390/22	690/32	390/22
FIXED GUNS/AMMUNITION		2-20 mm/400 Rds (MK I Sight System)			
FLEXIBLE GUNS/AMMUNITION		NONE			
ENGINE POWER USED FOR PERFORMANCE		COMBAT	NORMAL	NORMAL	NORMAL
WING LOADING	LBS./SQ.FT.	35.6	35.6	45.9	40.9
POWER LOADING ①	LBS./BHP.	6.5	7.5	9.7	8.6
V-MAX. SEA LEVEL	KN.	323	287	253	257
V-MAX./CRITICAL ALT.	KN./FT.	344/13400	327/19600	282/19000	289/19100
V-STALL GROSS WEIGHT ②	KN.	73.6	73.6	83.6	78.9
V-STALL WITHOUT FUEL ②	KN.	67.3	67.3	73.6	73.0
TIME-TO-CLIMB -10000FT-	MIN.	3.0	3.7	5.5	4.6
TIME-TO-CLIMB -20000FT-	MIN.	7.2	8.6	13.4	10.9
SERVICE CEILING	FT.	33800	33800	29100	31100
TAKE-OFF DISTANCE -CALM-	FT.	481	481	910	684
TAKE-OFF DISTANCE -15 KN-	FT.	301	301	605	444
TAKE-OFF DISTANCE -25 KN-	FT.	203	203	436	311
TAKE-OFF DISTANCE -50 FT. OBST.	FT.				
TAKE-OFF TIME	SECONDS				
RATE OF CLIMB -SL-	FT./MIN.	4030	2790	1930	2300
MAX. RANGE / V-AV. ③	N MI./KN.		1340/165	1775/145	1065/142
RANGE / V-AV. -60%NSP-③-	N MI./KN.				
SEARCH RADIUS / V-AV. -20%R-	N MI./KN.				
A.S.W. RADIUS / V-AV. -20%R-	N MI./KN.				
SCOUT RADIUS (S-1)	N MI.		370		
COMBAT RADIUS (B-1)	N MI.			650	240
ENGINE / PROP GEAR RATIO R-3350-26W / .4375					
ENGINE RATING BHP/RPM/ALT.	COMBAT	MILITARY	NORMAL	TAKE-OFF	
	3200/2900/SL-1000	2700/2900/SL-3700	2300/2600/SL-6200	2700/2900/SL	
	2920-2700/2900/3700	2100/2600/11500-14500	1900/2600/12000-17000		
	2600/2600/4900-10600				
	2220-2100/2600/14500				
Military, T.O., and Normal Ratings are with "Normal" Mixture.					
TANKAGE IN GALLONS		OIL	FUEL	OFFENSIVE ARMAMENT	
AUX. FIXED	PROTECTED		390	Fuselage-External (Douglas Bomb Ejector)	
	UNPROTECTED	32		(Alternate with drop tanks)	
	TOTAL-FIXED INTERNAL	32	390	Bombs: 1-2000#, 1-1600#, 1-1000# or 1-500#	
	DROPPABLE 2 @ 150 on wings		300	Depth Bombs: 1-325#	
	DROPPABLE			Mines: 1-2000# or 1-1000#	
TOTAL	32	690	Torpedo: 1-MK13-3		
NOTE			Wings (2-MK51-11 bomb racks)		
	① BHP AT MAX. CRIT. ALT.		(Alternate with drop tanks or radar)		
	② STALL - WITHOUT POWER		Bombs: 2-2000#, 2-1600#, 2-1000#, 2-500#, 2-250#		
	③ AT 1500' ALTITUDE		Depth Bombs: 2-325# Mines: 2-1000#		
		Torpedo: 2-MK13-3 Rockets: 2-11.75"AR (Tiny Tim) or 12-5" HVAR			

DATE 1 MAY, 1947

PAGE 1

RESTRICTED

MODEL AD-2

DECLASSIFIED IN ACCORDANCE WITH E. O. 11652

13610

AIRPLANE CHARACTERISTICS & PERFORMANCE

BUREAU OF AERONAUTICS, NAVY DEPT.

Performance is based on flight tests of the XBT2D-1 airplane.

Range and radius are based on engine specification fuel consumption data increased by 15% to conform with past experience.

 Scout Condition: Two MK-51 wing bomb racks with sway bracing and fuselage bomb ejector aboard. AN/APS-4 radar and rocket launchers not aboard. Addition of 12 MK-9 rocket launchers to Condition (1) decreases Vmax S.L. to 316 kn. and Vmax/ACA to 336 kn./13300 ft. Addition of 12-5" HVAR increases gross weight of Condition (1) to 15966# and decreases Vmax S.L. to 294 kn. and Vmax/ACA to 311 kn./13000 ft.

Notes:

1. AN/APS-4 radar carried on port wing bomb rack.
2. 12-100 # bombs or 12-250# bombs can be carried at MK-9 rocket launchers positions by replacing launchers with MK-55 bomb racks.
3. Minimum engine power and speed of 580 HP and 1100 rpm, respectively, limits maximum range and scouting radius of Condition (2) and also the bomber radius of Conditions (3) and (4) by requiring more fuel for reserve.
4. 20 gallons of AD1 fluid are available for 12 minutes at combat power at 1500 ft. altitude.
5. 200 ft. length is required to spot 20 planes on the 96' wide deck immediately aft of the forward ramp on the CV-9 Class carriers.

BOMBER COMBAT RADIUS FORMULA NO. B-1-CONDITIONS NOS. - 3 & 4					RADIUS=CLIMB+CRUISE-OUT+CRUISE BACK		
<u>WARM-UP</u> 20 min.	<u>RENDEZVOUS</u> 20 min. at sea level	<u>CLIMB</u> to 15000 ft.	<u>CRUISE OUT</u> at 15000 ft. 180 kts.TAS	<u>DROP TANKS</u> <u>DESCEND</u> to 1500 ft.	<u>COMBAT</u> 15 min. at 1500 ft.	<u>CRUISE BACK</u> at 15000 ft. 170 kts.TAS	<u>RESERVE</u> 60 min. at Vel. for Max.Range
<u>TAKE-OFF</u> 1 min.	at 60% N.S.P. Norm. Mix.	at Norm. Power Norm. Mix.	Norm. Mix.	DROP BOMBS FIRE ROCKETS	5 min. WEP. 10 min. Nor.Pr.	Norm. Mix.	Norm. Mix.

SCOUTING RADIUS FORMULA NO. S-1-CONDITION NO. - 2

RADIUS IS 1/3 RANGE AT VEL. FOR MAX. RANGE AT 1500 FT. Fuel for 20 min.warm-up,1 min.T.O. used at start of flight. Allowance for 60 min.at V.for max.range for rendezvous,landing and reserve carried ent.distance
 Practical scout radius is decreased approximately 10 nautical miles for each minute of combat power operation at 1500 ft. altitude.

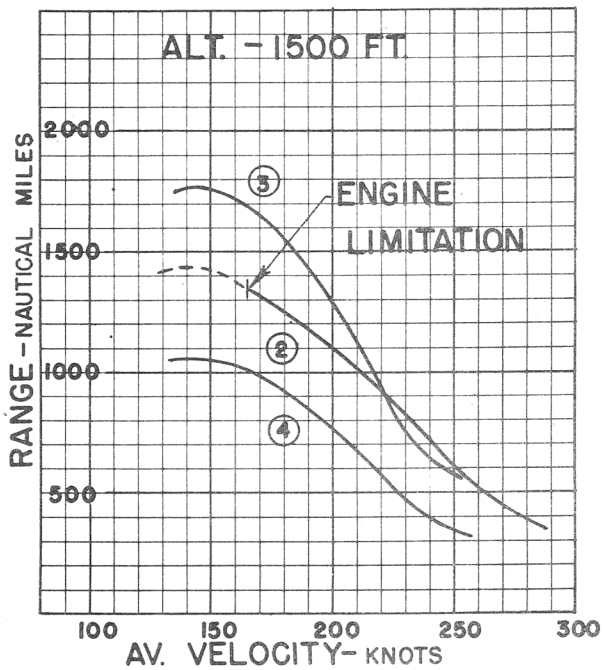
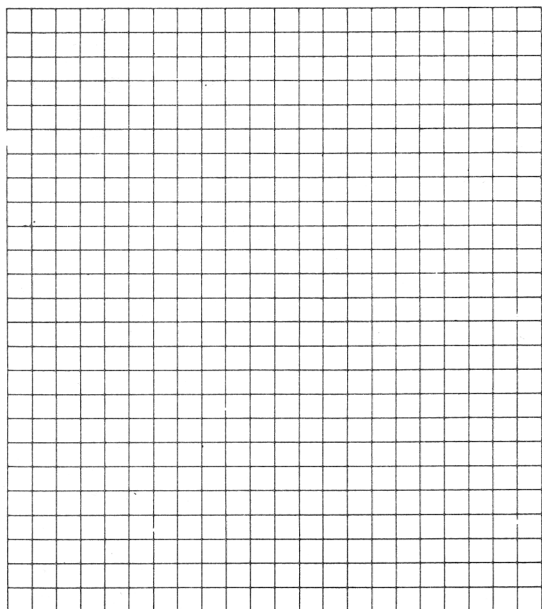
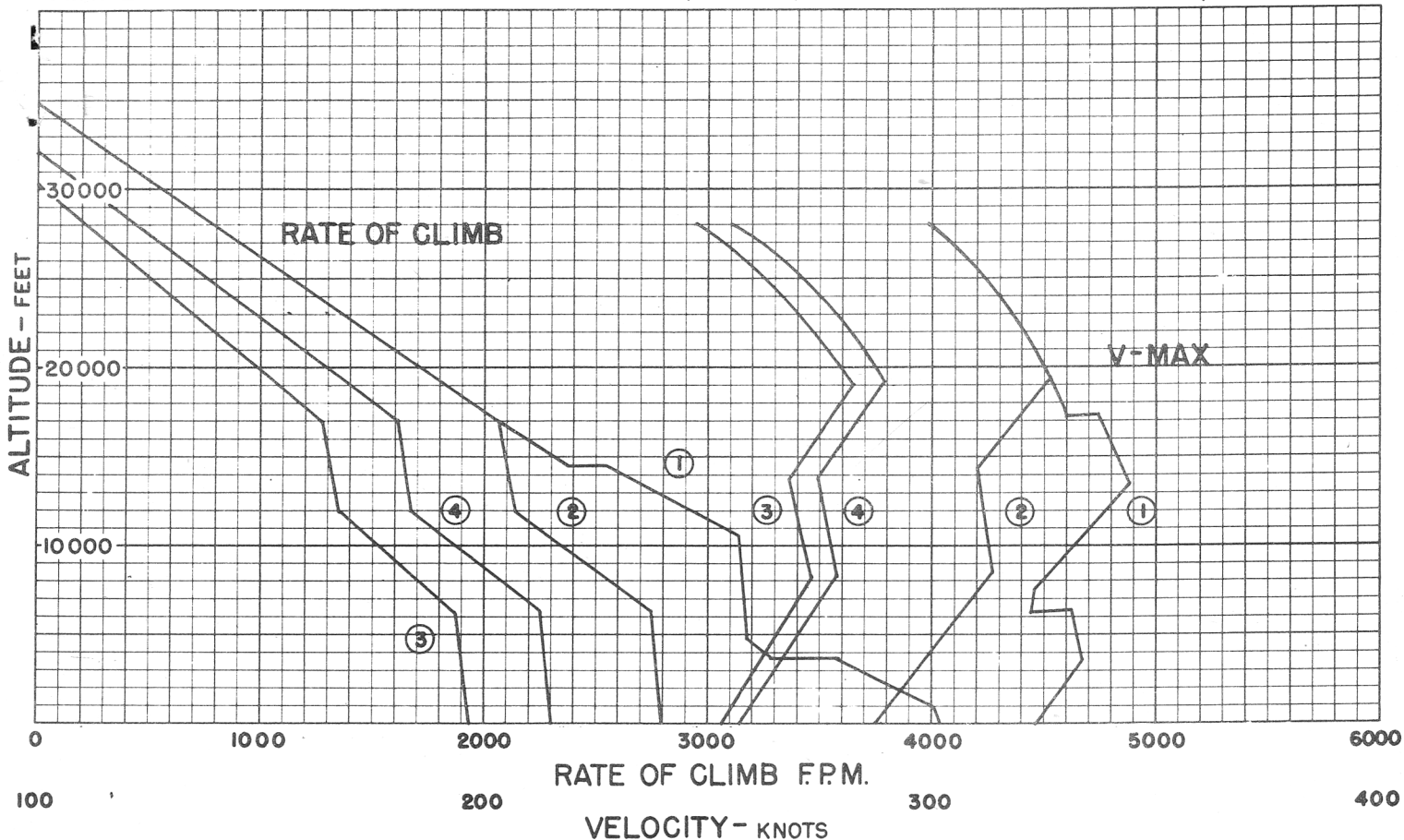

○ LOADING CONDITION COLUMN NUMBER

DECLASSIFIED IN ACCORDANCE WITH E. O. 11652



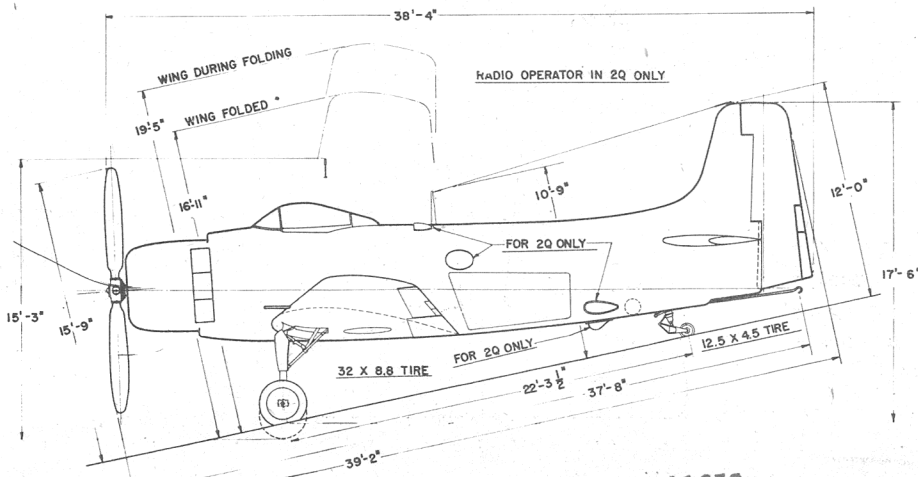
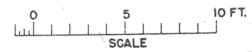
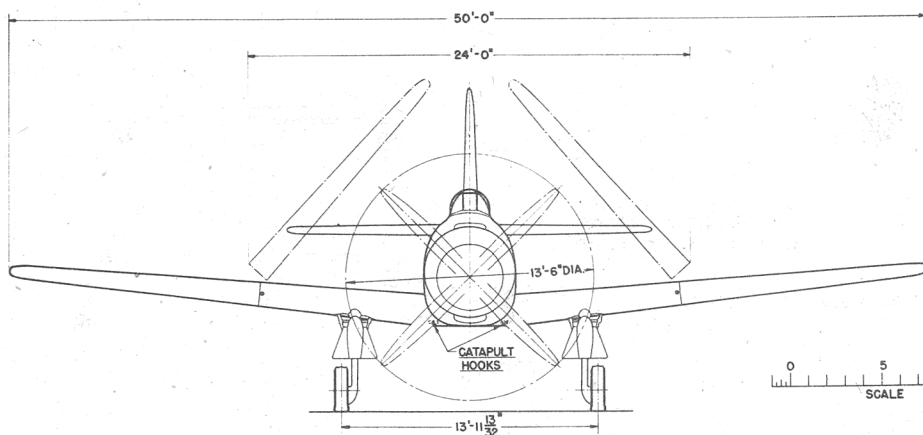
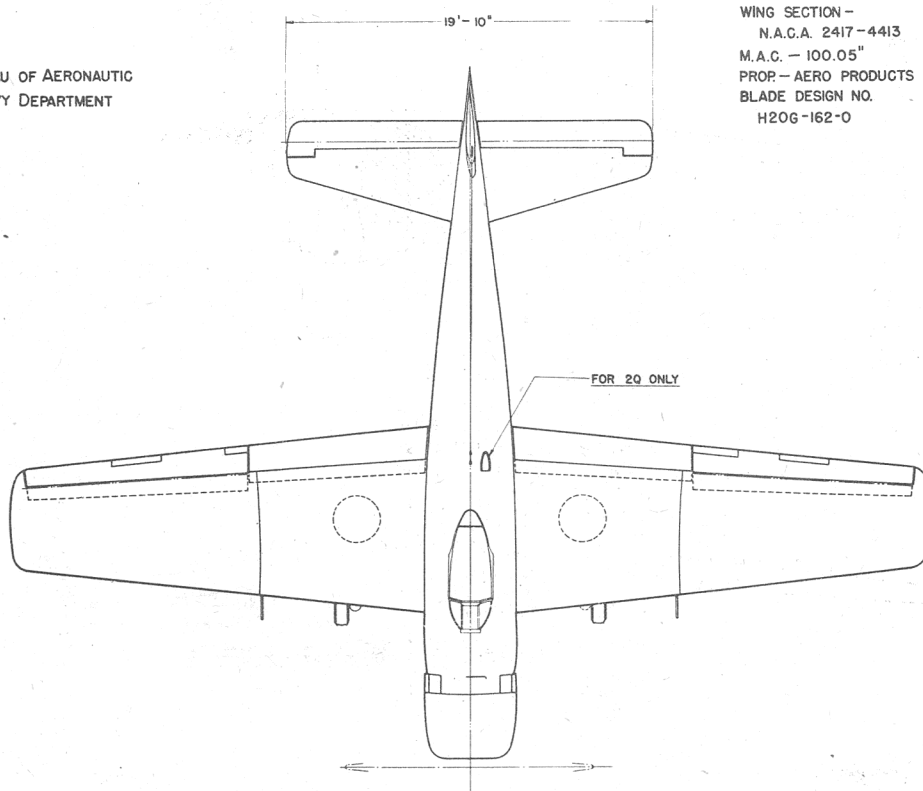

13
BUREAU OF AERONAUTIC
NAVY DEPARTMENT

WING AREA - 400 SQ. FT.
WING SECTION -
N.A.C.A. 2417-4413
M.A.C. - 100.05"
PROP. - AERO PRODUCTS
BLADE DESIGN NO.
H20G-162-0



DECLASSIFIED IN ACCORDANCE WITH E. O. 11652

BUREAU OF AERONAUTICS
NAVY DEPARTMENT

-  BULLET RESISTANT GLASS ARMOR PLATE
-  DEFLECTION PLATE
-  SELF-SEALING TANKS
- 

PROTECTION

- 1. PILOT FORWARD 9.15 LBS.
- 2. PILOT AFT 38.0 LBS.
- 3. ENGINE 148.33 LBS.
- 4. SELF-SEALING CELLS 266 LBS.

