

Standard Aircraft Characteristics NAVAER 1335A (REV. 1-55)

STANDARD AIRCRAFT CHARACTERISTICS

AD-4 "SKYRAIDER"

DOUGLAS

SERVICE

BUREAU OF AERONAUTICS
NAVY DEPARTMENT

WING AREA-400.3 FT.
WING SECTION:
ROOT-NACA 2417
TIP - NACA 4413
M.A.C.-100.06"
A.R.-6.25

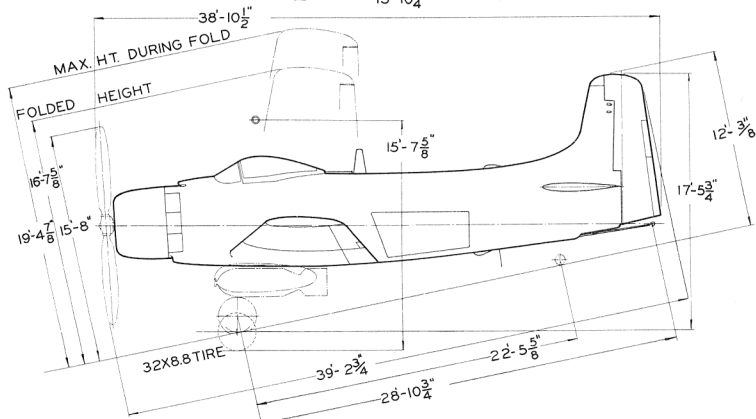
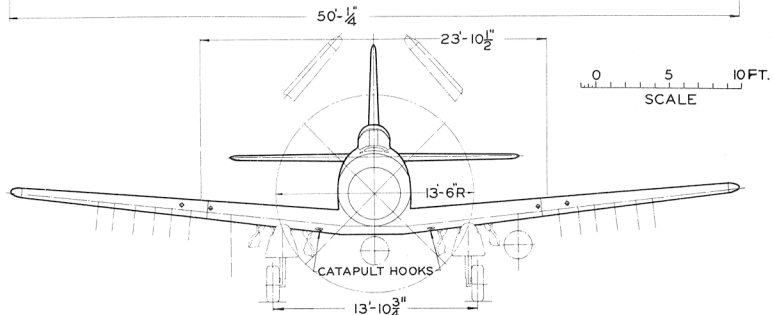
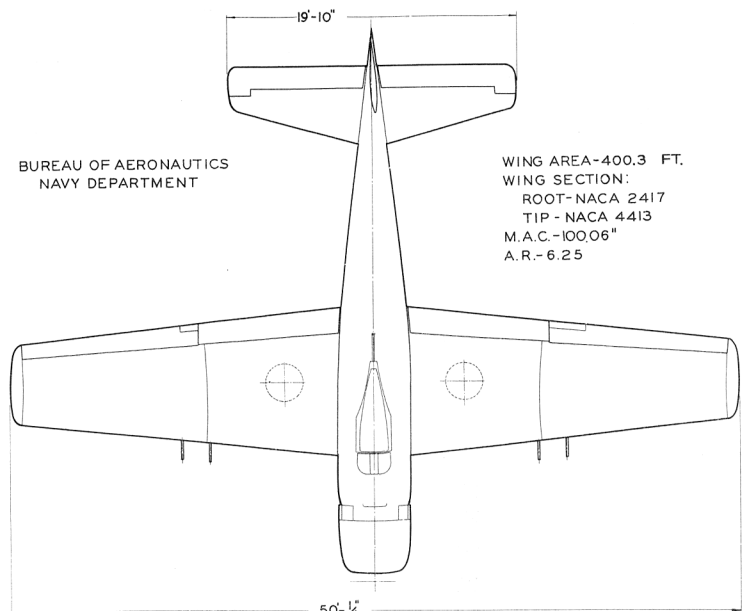

DESCRIPTIVE ARRANGEMENT

- ARMOR
- DEFLECTOR PLATE & WINDSHIELD
- S. S. TANK
- NON S.S. TANK

- PROTECTION
1. PILOT FORWARD 114.8 LBS.
 2. WINDSHIELD 26.9 LBS.
 3. AFT ARMOR 4.44 LBS.
 4. S. SEALING CELL 232.0 LBS.

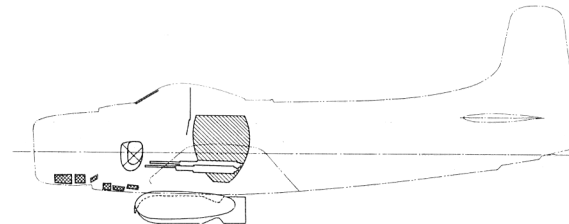
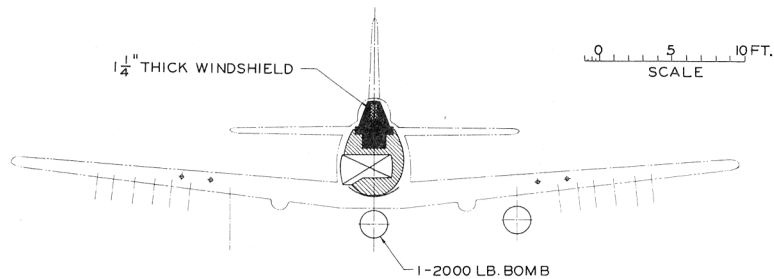
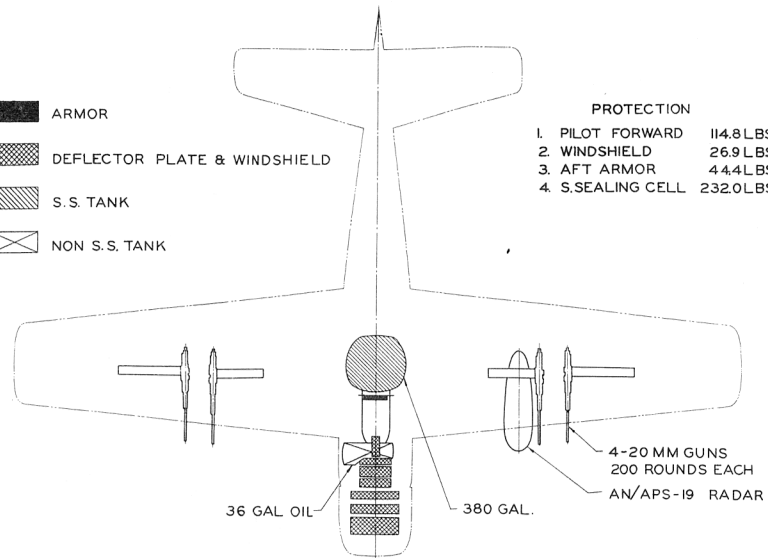

ARMAMENT & TANKS

Standard Aircraft Characteristics NAVAER 1335B (Rev. 1-55)

Standard Aircraft Characteristics NAVAER-1335C (Rev. 1-55)

POWER PLANT

NO. & MODEL(1) R-3350-26WA
 MFR..... Wright
 SUPERCH..... 1 Stage, 2 Speed
 RED. GR. RATIO..... 0.4375
 PROP. MFR..... Aero. Prod.
 BLADE DESIGN..... A642G8/M20A-162-0
 NO. BL./DIA..... 4/13' - 6"

RATINGS

	BHP.	@ RPM.	@ ALT.
T.O.	2,700	2,900	S.L.
MIL.	2,700	2,900	S.L.
	2,100	2,600	to 3,700'
			11,500
			to 14,500'
NORM.	2,300	2,600	S.L.
			to 6,200'
	1,900	2,600	12,000
			to 17,000'

SPEC. NO. N836-B

MISSION AND DESCRIPTION

The primary mission of the AD-4 is the destruction of sea and ground targets by dive bombing tactics. The airplane is also capable of torpedo, glide bombing, rocket attacks and tactical support missions. The AD-4 is designed to operate from all classes of naval aircraft carriers or from land bases.

It is equipped with a strengthened landing gear, G-2 compass, anti-G suit provisions, 4-20 MM cannon, and Aero 14 rocket launchers capable of carrying bombs up to 500 lbs.

The airplane is conventional in design and structure. Landing gear, canopy, flaps, wing folding, and three fuselage dive brakes are hydraulically operated. The pressure-balance type ailerons are operated by power boost. The rudder is equipped with a spring tab system, Longitudinal trim is achieved by an electrically adjustable stabilizer. Elevators, power plant, and engine mount are conventional. Oxygen for five hours is supplied. Bomb displacing gear at the center-line station is powder operated. Twenty gallons of ADI fluid are supplied for injection.

DEVELOPMENT

First Flight June 1949
 Service Use July 1949

WEIGHTS

<u>LOADINGS</u>	<u>LBS.</u>	<u>L.F.</u>
EMPTY.....	11,712
BASIC.....	12,649
DESIGN.....	15,5956.0
COMBAT.....	17,8186.0
MAX.T.O.(Field)...	25,000
(Cat.).....	25,000
MAX.LAND.(Field)...	21,000
(Arrest) 17,500

All weights are actual.

FUEL AND OIL

<u>GAL.</u>	<u>NO. TANKS</u>	<u>LOCATION</u>
380	1	Fuse., S.S.
150 or 300	1	Ctr. Drop
150 or 300	2	Wing Drop

FUEL GRADE.....115/145
 FUEL SPEC..applicable..MIL-F-5572

OIL

CAPACITY (Gals.).....36
 GRADE.....1100
 SPEC.....applicable..MIL-O-6082A

ORDNANCE

GUNS

<u>No.</u>	<u>Size</u>	<u>Location</u>	<u>Rds.</u>
4	20 mm	Wing	800

Mk. 1 Mod. 4 Gunsight

BOMBS & ROCKETS STATIONS

<u>Racks</u>	<u>Max. Cap.</u>	<u>Location</u>	<u>No.</u>
MK.51	2,300#	Inner Wing	2
Douglas Ejector	2,300#	Center Fuselage	1
Aero 14A	500#	Outer Wing	12

Max. Bomb Cap. (Ship) 6,500 lbs.
 (Shore) 9,900 lbs.

DIMENSIONS

WING
 AREA.....400 sq. ft.
 SPAN.....50' - 0"
 M. A. C.....8' - 4"
 LENGTH.....39' - 3"
 HEIGHT.....15' - 8"
 THREAD.....13' - 11"
 PROP. GRD. CLEAR.....6"

ELECTRONICS

VHF COMM.....AN/ARC-1 or -1A or AN/ARC-27
 RADIO ALTM.....AN/AFN-1
 RANGE REC.....R-23A/ARC-5
 RADIO REC.....AN/ARR-2A
 SEARCH & AIM RDR.....AN/APS-19A
 IFF.....AN/AFX-6

PERFORMANCE SUMMARY						
TAKE-OFF LOADING CONDITION		(1) LOW ALT. ATTACK 1-2000 lb. Store 12-5 in. HVAR 2-150 gal.ext.tanks	(3) LOW ALT. ATTACK 1-2000 lb. Store AN/APS-19 Radar	(4) LOW ALT. ATTACK 1-2000 lb. Store 2-1000 lb. Stores 12-5 in. HVAR		
TAKE-OFF WEIGHT	lb.	21,483	18,111	21,483		
Fuel	(Fixed/Drop) lb.	2,280/1,800	2,280/ - -	2,280/ - -		
Fayload	(Bombs/Rockets) lb.	2,000/1,680	2,000/ - -	4,000/1,680		
Wing loading	lb./sq.ft.	53.7	45.3	53.7		
Stall speed - power-off	kn.	89.0	80.5	89.0		
Take-off run at S.L. - calm	ft.	1,390	900	1,390		
Take-off run at S.L. 25 kn. wind	ft.	740	450	740		
Take-off to clear 50 ft. - calm	ft.	2,350	1,550	2,350		
Max. speed/altitude	(A) kn./ft.	256/20,000	244/20,000	255/20,000		
Rate of climb at S.L.	(A) fpm.	1,540	1,960	1,540		
Time: S.L. to 10,000 ft.	(A) min.	7.5	5.5	7.5		
Time: S.L. to 20,000 ft.	(A) min.	22.0	14.5	22.0		
Service ceiling (100 fpm)	(A) ft.	23,500	25,800	23,300		
Combat range	n.mi.	1,170	726	500		
Average cruising speed	kn.	197	189	206		
Cruising altitude(s)	ft.	15,000	15,000	15,000		
Combat radius	n.mi.	540	285	220		
Average cruising speed	kn.	184	177	180		
Mission time	hrs.	6.3	3.5	2.8		
COMBAT LOADING CONDITION		(2) Includes 1-2000 lb. Store				
COMBAT WEIGHT	lb.	17,818				
Engine power		Military				
Fuel	lb.	2,280				
Combat speed/combat altitude	kn./ft.	274/S.L.				
Rate of climb/combat altitude	fpm/ft.	2,880/S.L.				
Combat ceiling (500 fpm)	ft.	25,300				
Rate of climb at S.L.	fpm.	2,880				
Max. speed at S.L.	kn.	274				
Max. speed/altitude	kn./ft.	303/20,000				
LANDING WEIGHT	lb.	13,828				
Fuel	lb.	200				
Stall speed - power-off	kn.	70.5				
Stall speed - with approach power	kn.	68.2				

NOTES

REASON FOR REISSUE: Change in performance due to weight changes and change in combat loading configuration.

(A) Normal Rated Power.

(B) All Loading Conditions include 4-20mm guns, 800 rds. of ammunition, and 12 Aero - 14A racks.

(C) PERFORMANCE is based on Contractor's Flight Test data and NATC Evaluation Test data.

SPOTTING: A maximum operating spot aboard a CVA-19 (Angled Deck) class carrier consists of 42 aircraft on the flight deck with elevators and landing area clear and 41 aircraft on the hangar deck with hangar bay fire doors and elevators clear. Total 83 aircraft.

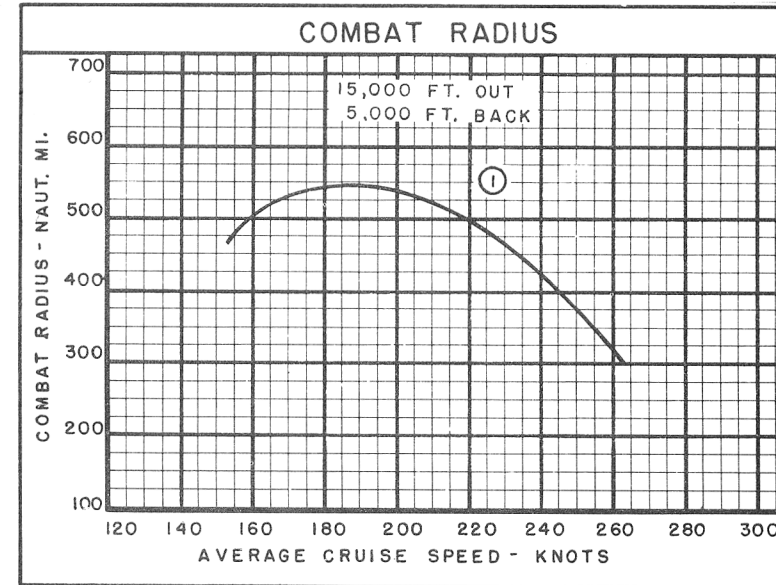
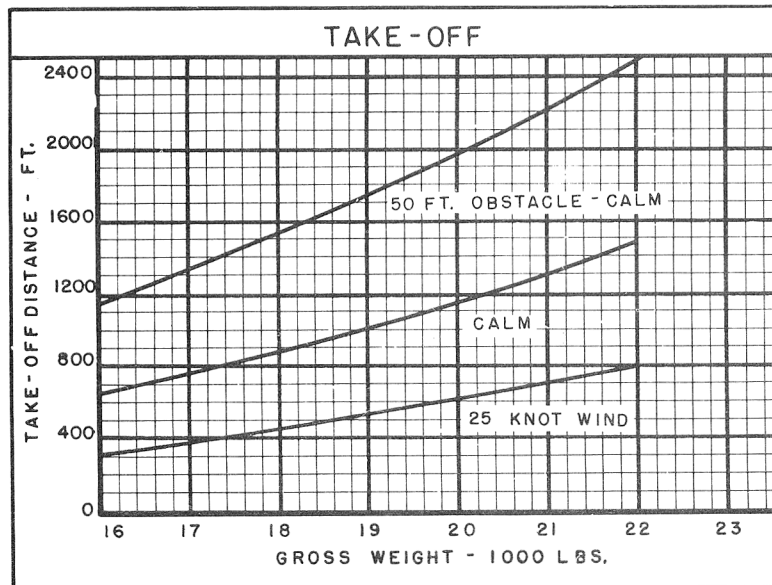
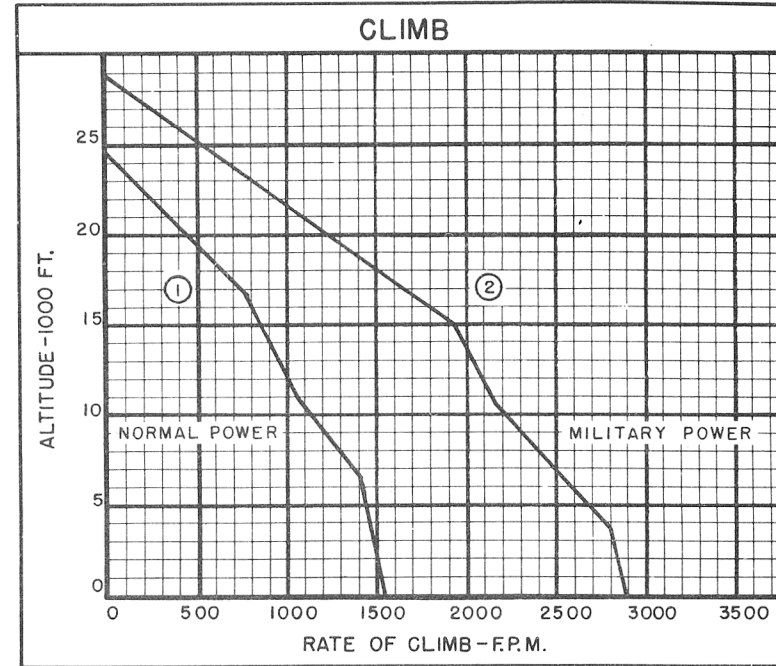
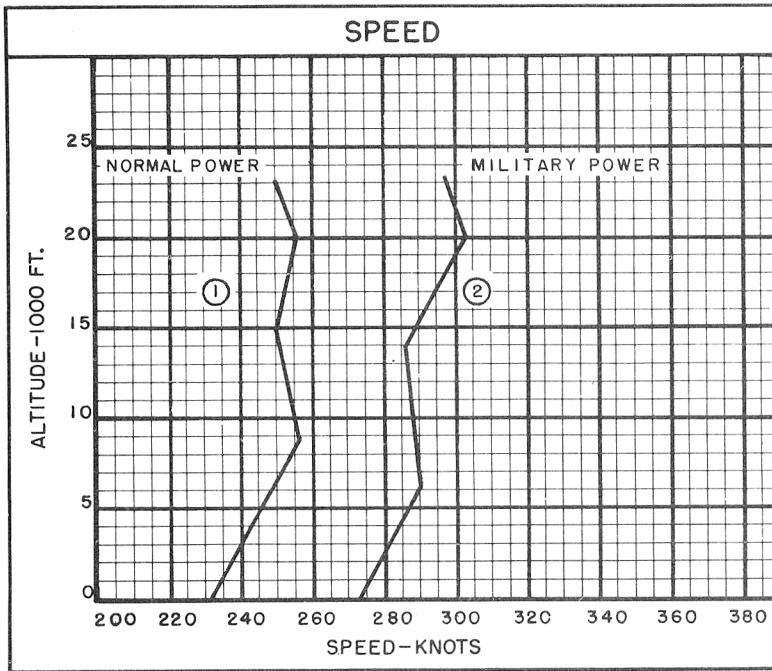

11

Standard Aircraft Characteristics NAVAER 1335E (Rev. 1-55)

○ LOADING CONDITION COLUMN NUMBER

NOTES

LOW ALTITUDE ATTACK COMBAT RADIUS PROBLEM (RECIPROCATING ENGINE)

WARM-UP, TAXI, TAKE-OFF: 10 minutes at normal rated power.
 CLIMB: On course to 15,000 feet at normal rated power.
 CRUISE-OUT: At 15,000 feet, at V for long range. External fuel tanks dropped when empty.
 DESCEND: To sea level. (No fuel used, no distance gained).
 DROP BOMBS, FIRE ROCKETS
 COMBAT: 15 minutes at sea level. (5 minutes at military rated power and 10 minutes at normal rated power).
 CLIMB: On course to 5,000 feet at normal rated power.
 CRUISE-BACK: At 5,000 feet at V for long range.
 RESERVE: 20 minutes at V for long range at sea level plus 5% of initial fuel load.

$$\text{COMBAT RADIUS} = \text{CLIMB} + \text{CRUISE-OUT} = \text{CLIMB} + \text{CRUISE-BACK}$$

$$\text{MISSION TIME} = \text{CLIMB} + \text{CRUISE-OUT} + \text{COMBAT} + \text{CLIMB} + \text{CRUISE-BACK}$$

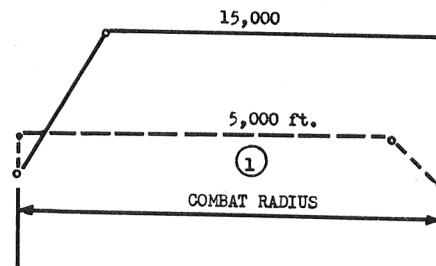

12

Standard Aircraft Characteristics NAVAER 1335F (Rev. 1-55)

LOADING CONDITION COLUMN NUMBER