

STANDARD AIRCRAFT CHARACTERISTICS

CLEARED
FOR OPEN PUBLICATION

A3D-1 "SKYWARRIOR"

28 OCT 1985

COMNAVAIRSYSCOM

DOUGLAS CLASSIFICATION (CANCELED) (██████████) BY AUTHORITY OF

AIR-7203

ON 10-21-85

J. H. Persons
(SIGNATURE)

Security Spec'l.
(RANK)

NAVAL AIR SYSTEMS COMMAND
DEPARTMENT OF THE NAVY

A3D-1

Standard Aircraft Characteristics NAVAER 1335A (REV. 1-55)

15 SEPTEMBER 1959

[Signature]
A. W. Frascella
Public Information Officer
By direction of the Commander

~~CONFIDENTIAL~~

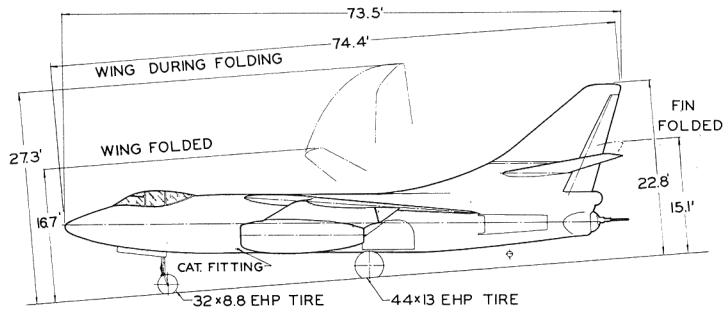
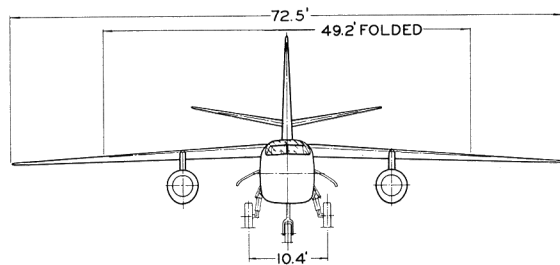
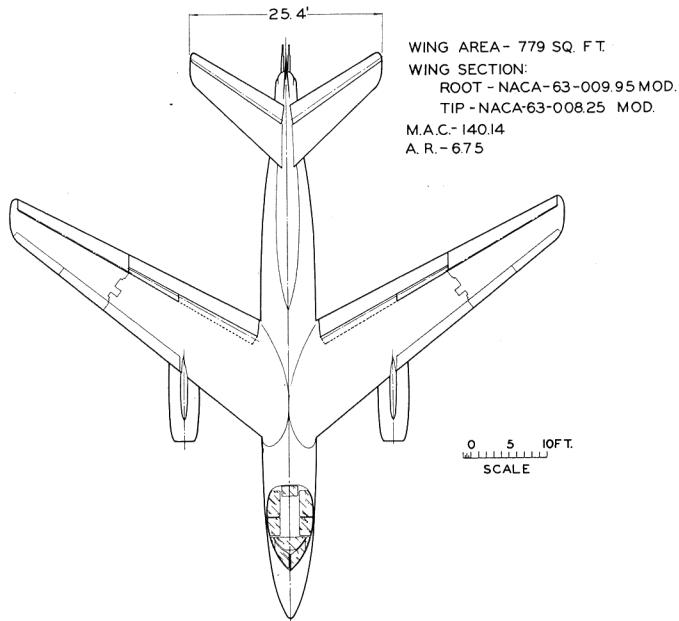

DESCRIPTIVE ARRANGEMENT

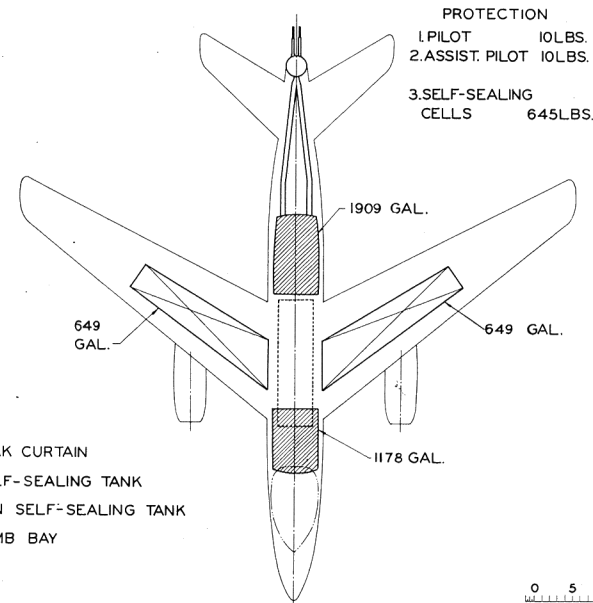

- FLAK CURTAIN
- ▨ SELF-SEALING TANK
- ▧ NON SELF-SEALING TANK
- ▤ BOMB BAY

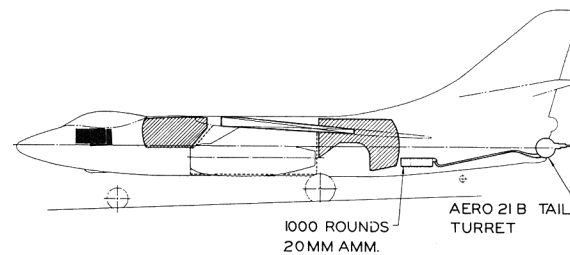
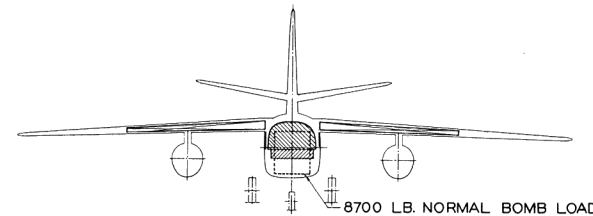

ARMAMENT & TANKAGE

POWER PLANT

No. & Model ----- (2) J57-P-6
 Mfr. ----- Pratt & Whitney
 Eng. Spec.No.---- N-1671-E (5-10-55)
 Type ----- Axial Comp
 Length ----- 159 in.
 Diameter ----- 41 in.
 No. & Type Assist--12-5KS4500 JATO
 Tail Pipe Nozzle---Const. Exit Area

RATINGS

Sea Level Static

	Thrust ^{HP}		R.P.M.	
	Lb.	N ₁	N ₂	
Maximum	10000	6130	9900	
Military	9500	6030	9800	
Normal	8250	5770	9550	

Spec No. N-1671-E

ORDNANCE

Maximum Bomb Capacity:
 12,800 lbs.

Bombs -----	4-2000 lb.	G.P.
	8-1600 lb.	A.P.
	6-1000 lb.	G.P.
	8-500 lb.	G.P.

Mines -----	2-2000 lb.	Mk.10
	4-2000 lb.	Mk.25
	6-1000 lb.	Mk.36
	8-500 lb.	Mk.50

Special Stores

Guns/Amm.

2-20mm M3L/500 rounds per gun.
 Tail Turret System ----- Aero 21B
 Bomb Director Mk.5 ASB-1A

MISSION AND DESCRIPTION

The primary mission of the A3D-1 airplane is the attack and destruction of enemy ground and surface targets.

The airplane has a conventional swept-wing structure. Two turbo-jet engines are enclosed in under-wing nacelles. Provisions are made for a three-man crew; a pilot, a bomber-assistant pilot, and a gunner-navigator.

The tricycle landing gear, arresting gear, wing-fold and tail-fold mechanisms, single-slotted wing flaps, fuselage speed brakes, and power mechanisms for rudder, elevator and ailerons are operated by hydraulic power. The horizontal stabilizer is adjustable for trim in flight. Leading edge slats are actuated automatically by aerodynamic loads.

Anti-skid braking is provided. The JATO installation accommodates twelve 4500-pound-thrust bottles. In-flight refueling provisions are provided. A landing deceleration chute is provided.

DEVELOPMENT

First Flight ----- September 1953
 Service Use ----- April 1956

DIMENSIONS

Wing:
 Area ----- 779 sq. ft.
 Span ----- 72.5 ft.
 M.A.C. ----- 140.14 in.
 Sweepback ----- 36°

Length ----- 74.4 ft.
 Height ----- 22.8 ft.
 Tread ----- 10.4 ft.

WEIGHTS

Loading	Lbs.	L.F.
Empty	35,999 (A)	
Basic	36,178	
Design	55,942	2.67
Combat	59,942	2.49
Take-Off, Field	70,000	2.13
Landing Cat.	70,000	2.13
a. Field	56,000	
b. Carrier	49,000	

FUEL AND OIL

Gal.	No Tanks	Location
3087	2	Fuselage
1298	2	Wing
Fuel Grade-----JP-4 or JP-5		
Fuel Spec (applicable)---MIL-F-5624		

OIL

Gal.	No. Tanks	Location
11	2	Integral with Engine
Oil Spec-----MIL-L-7808		

ELECTRONICS

UHF Dir. Finder ----- AN/ARA-25
 VOR Homing ----- *AN/ARN-14E
 VHF Trans-Rec. ----- AN/ARC-27A
 HF Transmitter ----- AN/ART-13
 HF Receiver ----- AN-ARR-15A
 IFF ----- AN/APX-6B & AN/APA-89
 Interphone ----- AN/AIC-4A
 Radio Altimeter ----- AN/APN-22

* Alternate ----- AN/ARN-21

PERFORMANCE SUMMARY

TAKE-OFF LOADING CONDITION	(1) HIGH ALTITUDE ATTACK 2-3100 LB. STORES	(3) HIGH ALTITUDE ATTACK 2-2025 LB. STORES	(5) LOW ALTITUDE ATTACK 3-1300 LB. STORES	(7) LOW ALTITUDE ATTACK 1-2025 LB. STORE	(9) FERRY NO STORES FULL INT. FUEL
TAKE-OFF WEIGHT	lb. 70,000	70,000	70,000	70,000	68,377
Fuel (JP-5)	lb. 25,145	27,290	27,352	29,411	29,818
Payload	lb. 6200	4050	3900	2025	NONE
Wing loading	lb./sq.ft. 89.9	89.9	89.9	89.9	87.8
Stall speed - power-off	kn. 129.5	129.5	129.5	129.5	127.9
Take-off run at S.L. - calm (A)	ft. 4740	4740	4740	4740	4410
Take-off run at S.L. 25 kn. wind (A)	ft. 3320	3320	3320	3320	3090
Take-off to clear 50 ft. - calm (B)	ft. 6550	6550	6550	6550	6140
Max. speed/altitude (A)	kn./ft. 544/1700	544/1700	544/1700	544/1700	544/1700
Rate of climb at S.L. (A)	fpm. 4190	4190	4190	4190	4300
Time: S.L. to 20,000 ft. (A)	min. 6.0	6.0	6.0	6.0	5.8
Time: S.L. to 30,000 ft. (A)	min. 11.0	11.0	11.0	11.0	10.5
Service ceiling (100 fpm) (A)	ft. 39,200	39,200	39,200	39,200	39,700
Combat range	n.mi. 2070	2325	2345	2600	2680 (c)
Average cruising speed	kn. 457	457	457	457	457
Cruising altitude(s)	ft. 36,400/43,000	36,400/43,950	36,400/44,300	36,400/45,200	37000/45,900
Combat radius /Mission time	n.mi./hr. 1080/4.7	1180/5.2	1085/4.9	1195/5.3	
Average cruising speed	kn. 457	457	457	457	
IFR-Radius/Mission time (B)	n.mi./hr. 1778/8.0			1775/8.1	
IFR-Fuel Transf/distance (B)	lb./n.mi. 16730/800			13880/940	
COMBAT LOADING CONDITION	(2) 60% FUEL STORES RETAINED	(4) 60% FUEL STORES RETAINED	(6) 60% FUEL STORES RETAINED	(8) 60% FUEL STORES RETAINED	
COMBAT WEIGHT	lb. 59,942	59,084	59,059	58,236	
Engine power	MAXIMUM	MAXIMUM	MAXIMUM	MAXIMUM	
Fuel	lb. 15,087	16,374	16,411	17,647	
Combat speed/combat altitude	kn./ft. 495/39,800	494/40,200	535/Sea Level	535/Sea Level	
Rate of climb/combat altitude	fpm/ft. 770/39,800	700/40,200	5140/Sea Level	5230/Sea Level	
Combat ceiling (500 fpm)	ft. 40,900	41,200	41,200	41,500	
Rate of climb at S.L.	fpm. 5050	5130	5140	5230	
Max. speed at S.L.	kn./M 535/.810	535/.810	535/.810	535/.810	
Max. speed/ Mach No./Alt.	kn./ft. 545/.829/1700	545/.829/1700	545/.829/1700	546/.830/1700	
Max. speed at 35,000 ft.	lb. 510/.886	510/.886	510/.886	510/.886	
LANDING WEIGHT	lb. 41,862	41,984	41,424	41,344	
Fuel	lb. 3207	3324	2676	2780	
Stall speed - power-off	appr.pwr. kn/ kn. 100.1/98.2	100.2/98.4	99.6/97.7	99.5/97.5	
Landing Distance - Ground run/50 ft. obst.	ft./ft. 4630/6620	4640/6630	4590/6580	4580/6570	

NOTES

PERFORMANCE BASIS: Naval Air Test Center flight tests of A3D-1 and contractor flight tests of the A3D-2.

- (A) Maximum Thrust
 (B) One rendezvous in-flight refueling from A3D-2 Tanker
 (C) With JP-4 fuel (28,503 lb.) instead of JP-5, ferry range is decreased to 2540 n.mi.

SPOTTING: A total of 27 airplanes can be accommodated in a landing spot on the flight and hangar decks of a CVA-19 class angled deck carrier.

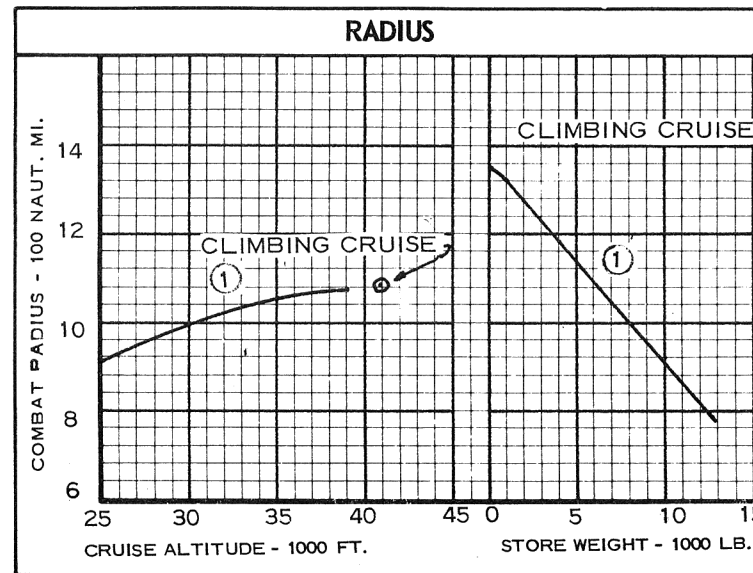
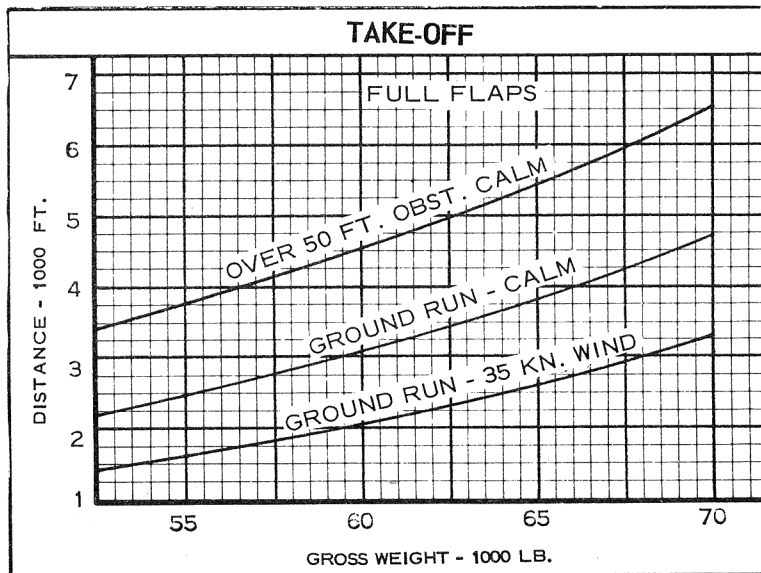
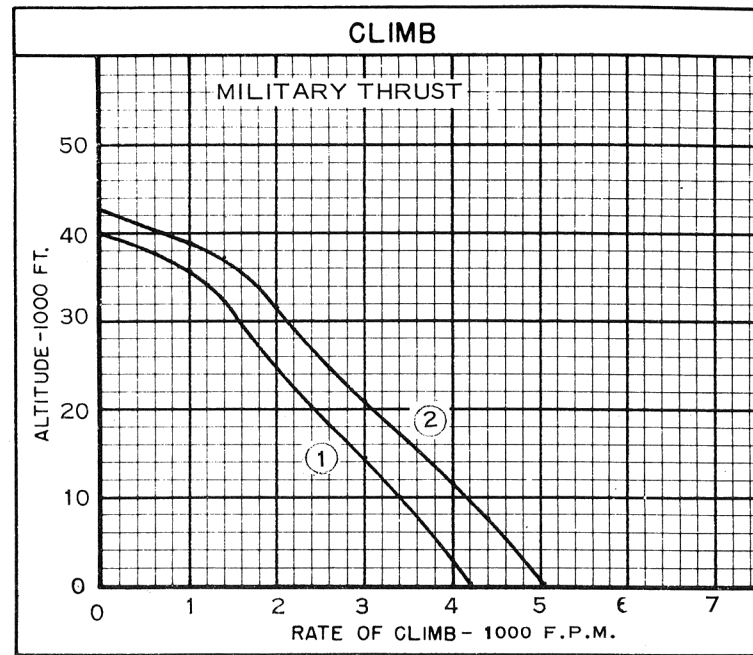
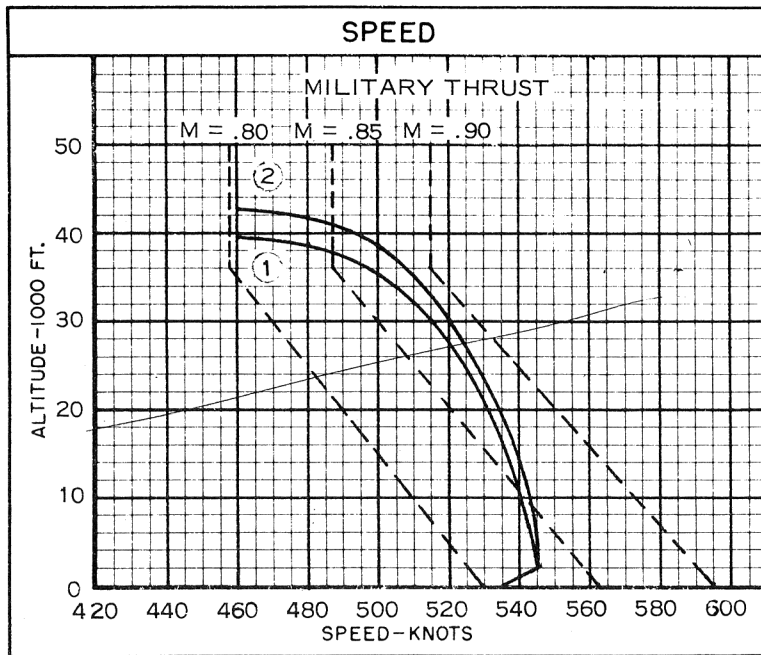

Standard Aircraft Characteristics NAVAER 1335E (Rev. 1-55)

○ LOADING CONDITION COLUMN NUMBER

NOTES

HIGH ALTITUDE ATTACK

WARM-UP, TAKE-OFF AND ACCELERATE: 5 minutes at normal rated thrust at sea level
 CLIMB: On course to optimum cruise altitude with maximum rated thrust
 CRUISE-OUT: At altitudes and speeds for maximum range
 CLIMB: At maximum rate of climb with maximum rated thrust on course to cruise ceiling.
 BOMB RUN: Cruise in level flight 15 minutes at normal rated thrust at combat altitude
 DROP BOMBS
 EVASIVE ACTION: 2 minutes at maximum speed with normal rated thrust at combat altitude (no distance gained).
 ESCAPE: 8 minutes at maximum speed with normal rated thrust (climb to optimum cruising altitude is accomplished in evasive action and escape periods).
 CRUISE-BACK: At altitudes and speeds for maximum range
 RESERVE: 20 minutes at speed for maximum endurance at sea level plus 5% of initial fuel load

HIGH ALTITUDE ATTACK WITH IN-FLIGHT REFUELING

WARM-UP, TAKE-OFF AND ACCELERATE: 5 minutes at normal rated thrust at sea level
 CLIMB: On course to optimum cruise altitude with maximum rated thrust.
 CRUISE-OUT: At altitudes and speeds for maximum range.
 REFUEL: 15 minutes at 35,000 feet at speed for maximum endurance. Refuel to full internal fuel
 CRUISE-OUT: At altitudes and speeds for maximum range
 CLIMB: At maximum rate of climb with maximum rated thrust on course to cruise ceiling
 BOMB RUN: Cruise in level flight 15 minutes at normal rated thrust at combat altitude
 DROP BOMBS
 EVASIVE ACTION: 2 minutes at maximum speed with normal rated thrust at combat altitude (no distance gained).
 ESCAPE: 8 minutes at maximum speed with normal rated thrust (climb to optimum cruising altitude is accomplished in evasive action and escape periods).
 CRUISE-BACK: At altitudes and speeds for maximum range
 RESERVE: 20 minutes at speed for maximum endurance at sea level plus 5% of initial fuel load.

LOW ALTITUDE ATTACK

WARM-UP, TAKE-OFF AND ACCELERATE: 5 minutes at normal rated thrust at sea level
 CLIMB: On course to optimum cruise altitude with maximum rated thrust.
 CRUISE-OUT: At altitudes and speeds for maximum range
 DESCEND TO SEA LEVEL: No fuel consumed. No distance credit
 DROP BOMBS
 COMBAT: 5 minutes at maximum rated power at sea level (no distance gained)
 CLIMB: On course to optimum cruise altitude with maximum rated thrust
 CRUISE-BACK: At altitudes and speeds for maximum range
 RESERVE: 20 minutes at speed for maximum endurance at sea level plus 5% of initial fuel load

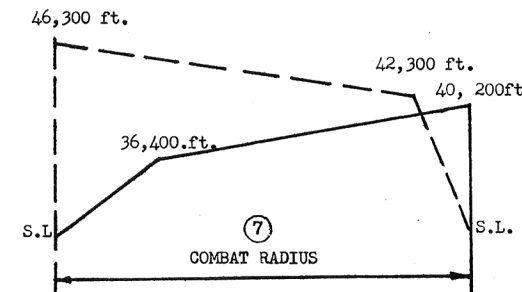
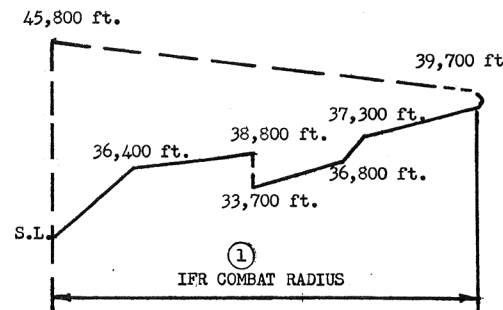
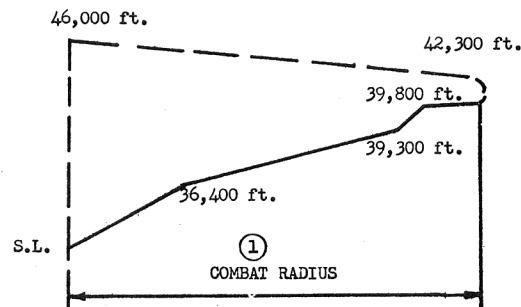

○ LOADING CONDITION COLUMN NUMBER

Standard Aircraft Characteristics NAVAR 1335F (Rev. 1-55)