

STANDARD AIRCRAFT CHARACTERISTICS
A3D-2Q SKYWARRIOR

DECLASSIFIED

DOUGLAS

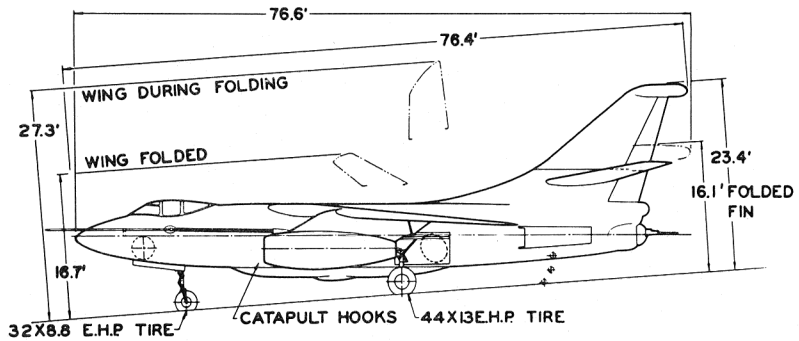
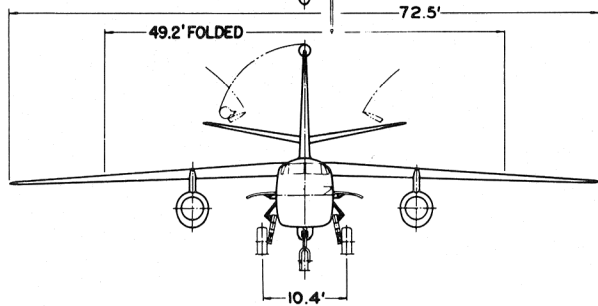
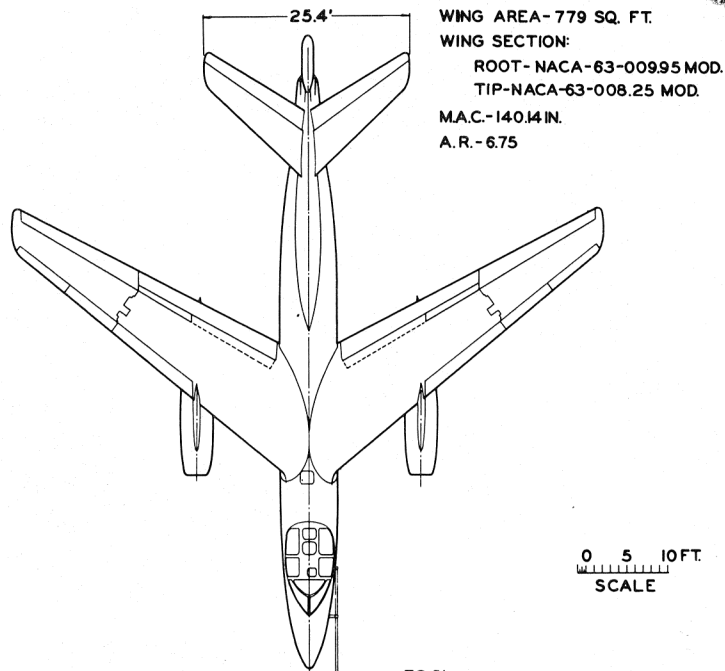

DESCRIPTIVE ARRANGEMENT

PROTECTION

1. PILOT	10 LBS
2. NAVIGATOR - ASST. PILOT	10 LBS.
3. GUNNER - RADIOMAN	10 LBS.
4. SELF-SEALING CELLS	741 LBS.

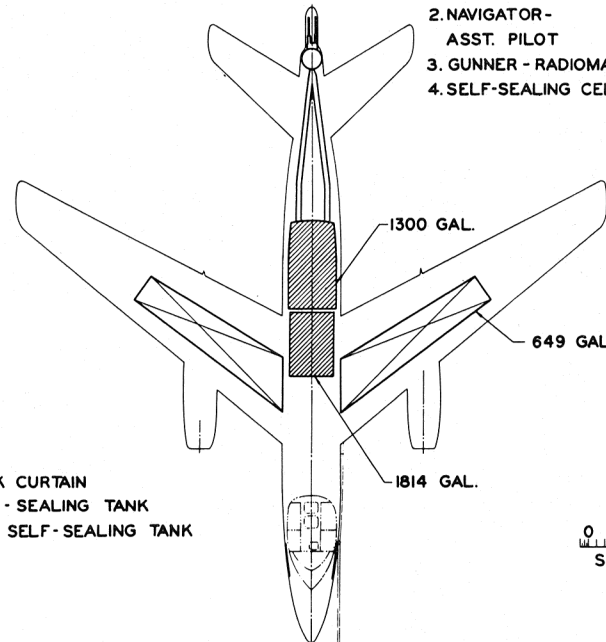

- FLAK CURTAIN
- ▨ SELF-SEALING TANK
- ▧ NON SELF-SEALING TANK

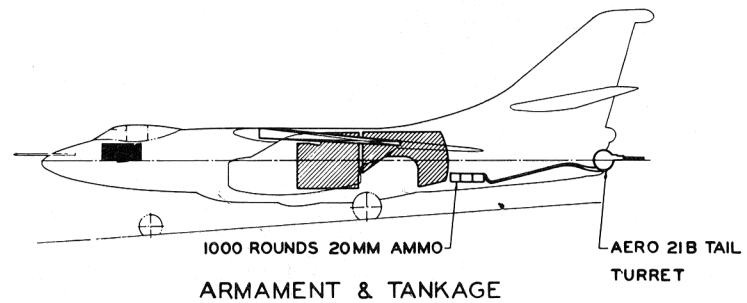
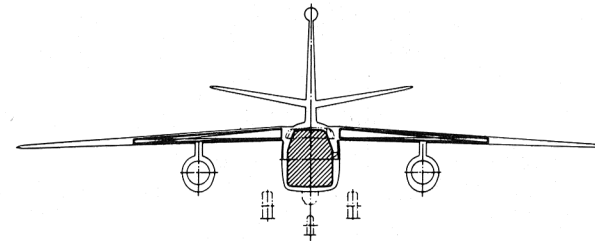

ARMAMENT & TANKAGE

POWER PLANT

No. & Model.....(2) J57-P-10
 Mfr.Pratt & Whitney
 Eng. Spec. No. N-1700-A (2-2-55)
 TypeTurbojet
 Compr.Dual rotor, Axial Flow
 Length158 in.
 Diameter 41 in.
 No. & Type Assist.12-5KS4500 JATO
 Tail Pipe NozzleConstant Exit Area

RATINGS

Sea Level Static

	THRUST		RPM **	
	LB.		N ₁	N ₂
Maximum	10500	6150	9900	
Military	10500	6150	9900	
Normal	9000	5900	9650	

*N₁: Speed of low pressure compressor

**N₂: Speed of high pressure compressor

FUEL AND OIL

Gal.	No. Tanks	Location
3114	2	*Fuselage
1298	2	Wing
4412		

Fuel gradeJP-4 or JP-5
 Fuel spec.MIL-F-5624

*Self-sealing

OIL

Gal.	No. Tanks	Location
11	2	Integral with eng.
Oil spec.		MIL-L-7808

MISSION AND DESCRIPTION

The principal mission of the A3D-2Q airplane is effective search for enemy radar. It can operate from land bases and from carriers.

The airplane is conventional with two turbo-jet engines in under-wing nacelles. Provisions are incorporated for a crew of seven: a pilot, a navigator-assistant pilot, a gunner-radioman, four ECM operators including an evaluator.

The tricycle landing gear, arresting gear, wing-fold and tail-fold mechanisms, single-slotted wing flaps, fuselage speed brakes, and power mechanisms for rudder, elevator and ailerons are operated by hydraulic power. The horizontal stabilizer is electrically adjustable for trim in-flight. Leading edge slats are actuated automatically by aerodynamic loads.

DEVELOPMENT

Contract: NOa(s) 55-205 Five airplanes
 NOa(s) 57-181 Eight airplanes
 NOa(s) 57-181 Amendment #2 14 May 1958
 Twelve airplanes (cambered leading edge wing)

First Flight: 12-10-58
 First Fleet Delivery: November 1959

DIMENSIONS

Wing:
 Area 779 sq. ft.
 Span 72.5 ft.
 M.A.C.140.14 in.
 Sweepback36°
 Length76.4 ft.
 Height.....23.4 ft.
 Tread10.4 ft.

WEIGHTS

Loading	Lbs.	L.F.
Empty	41,193	
Basic	41,927	
Design	55,942	3.40
Combat	61,593	3.09
Max. T.O. (Land)	78,000	2.44
Max. T.O. (Cat)	73,000	2.60
Max. Land (Land)	56,000	
Max. Landing (Carrier)	49,000	

ELECTRONICS

UHF Xntr-Rec.AN/ARC-27
 IFFAN/APX-6B & AN/APA-89
 Radar Altimeter AN/APN-22
 TACAN AN/ARN-21
 Radio Compass AN/ARN-6
 Search Radar AN/ASB-1B
 Video Omni-Range AN/ARN-14E
 VHF Xntr-Rec. AN/ARC-1
 Pulse Analyzer AN/ALA-3
 Countermeas. Rec. AN/ALR-8
 Radar Rec. AN/ALR-3
 Direction Finder AN/APA-69
 Signal Analyzer AN/APA-74
 Radar Rec. AN/APR-9
 Radar Rec. AN/APR-13
 Range Rec. AN/ARC-5
 HF Xntr-Rec. AN/ARC-38
 Radio Rec. AN/ARC-40
 Radio Direction Finder ...AN/ARA-25
 I.C.S.- Transistorized I.C.S. (DAC)
 By retrofit:
 Radar SetAN/APX-175
 Comm. SetAN/ALR-14
 DECM AN/ALQ-35/41/51

ORDNANCE

GUNS/AMM.
 2-20mm (M3) /500 rds. per gun
 Tail Turret System Aero 21B

PERFORMANCE SUMMARY

TAKE-OFF LOADING CONDITION	(1) Limit Carrier T.O. Wt. High Alt Reconnaissance	(3) Full Fuel High Altitude Reconnaissance			
TAKE-OFF WEIGHT (A)	lb.	73,000	74,483		
Fuel (JP-5)	lb.	28,518	30,001		
Payload	lb.	1894	1894		
Wing loading	lb./sq. ft.	93.7	95.6		
Stall speed - power-off (B)	kn.	132	134		
Take-off run at S.L. - calm (B)	ft.	4460	4700		
Take-off run at S.L. 25 kn. wind (B)	ft.	2940	3150		
Take-off to clear 50 ft. - calm (B)	ft.	6270	6560		
Max. speed/altitude	kn./ft.	557/S.L.	557/S.L.		
Rate of climb at S.L.	fpm	5030	4910		
Time: S.L. to 20,000 ft.	min.	5.2	5.3		
Time: S.L. to 30,000 ft.	min.	9.3	9.6		
Service ceiling (100 fpm)	ft.	39,000	38,600		
Combat range	n.mi.	2260	2370		
Average cruising speed	kn./M	459/.80	459/.80		
Cruising altitude(s)	ft.	35,400 - 43,200	35,000 - 43,200		
Combat radius /Mission Time	hr./n.mi.	1110/4.8	1160/5.1		
Average cruising speed	kn./M	459/.80	459/.80		
IFR-Radius/Mission Time	n.mi./hr.	1510/6.9 (C)	1600/7.3 (D)		
IFR-Fuel Trans./Distance	lb./n.mi.	10,530/650	11,150/825		
COMBAT LOADING CONDITION	(2) 60% Fuel	(4) 60% Fuel			
COMBAT WEIGHT	lb.	61,593	62,483		
Engine power		MILITARY	MILITARY		
Fuel	lb.	17,117	18,000		
Combat speed/combat altitude	kn./ft.	487/41,000	487/40,800		
Rate of climb/combat altitude	fpm/ft.	520/41,000	520/40,800		
Combat ceiling (500 fpm)	ft.	41,300	40,900		
Rate of climb at S.L.	fpm	6150	6050		
Max. speed at S.L.	kn./M	557/.84	557/.84		
Max. speed at 35,000 ft.	kn./M	511/.89	510/.88		
LANDING WEIGHT	lb.	47,617	47,691		
Fuel	lb.	3135	3209		
Stall speed - power-off /Apr. Pwr	kn./kn.	107/105	107/105		
Land. Dist. Gr. Run/Over 50 ft. (E)	ft./ft.	5315/6030	5320/6035		

NOTES

- (A) The limit catapult take-off weight of 73,000 pounds is consistent with current operating bulletins. Under emergency conditions increased take-off weights may be utilized.
- (B) Full flaps
- (C) One refueling from A3D-2 cambered wing tanker.
(Tanker T.O. Wt. = 73,000 lb.)
- (D) One refueling from A3D-2 cambered wing tanker.
(Tanker T.O. Wt. = 78,000 lb.)

- (E) Without chute. With chute distance is decreased approximately 2400 ft.
- (F) All loadings include IFR probe.
- (G) Performance Basis: NATC & Contractor's flt. test of the Model A3D-2 & 2Q. Range & radii based on flt. test fuel consumption.
- (H) Spotting: A total of 27 aircraft can be accommodated in the landing spot of the flight and hangar decks of a CVA-19 class angle-deck carrier.

137124

DECLASSIFIED

SERVICE

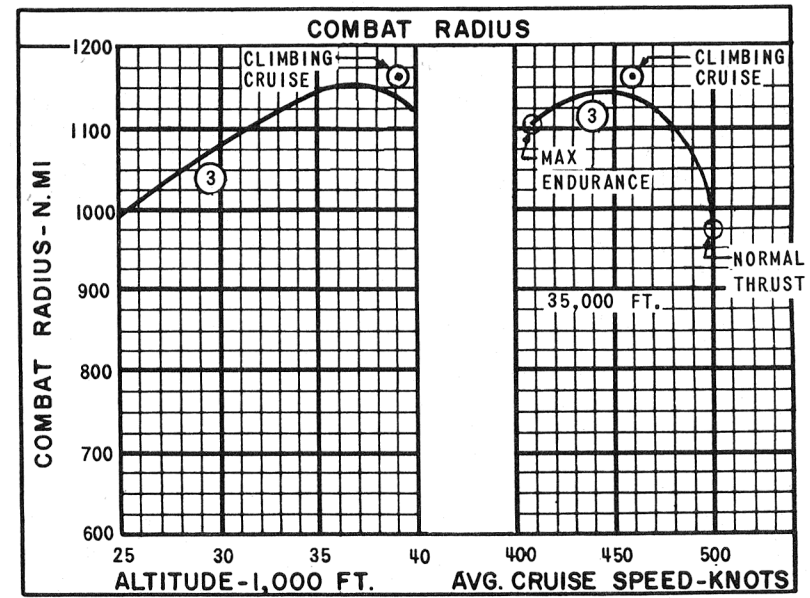
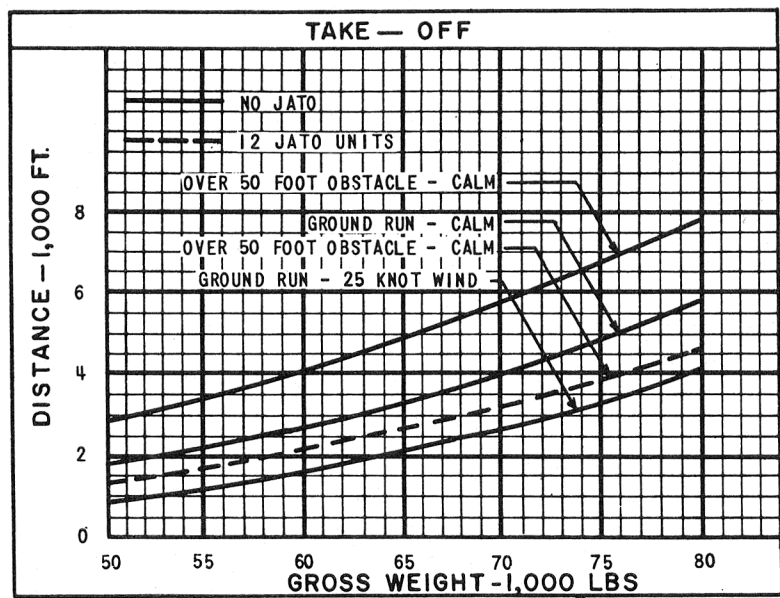
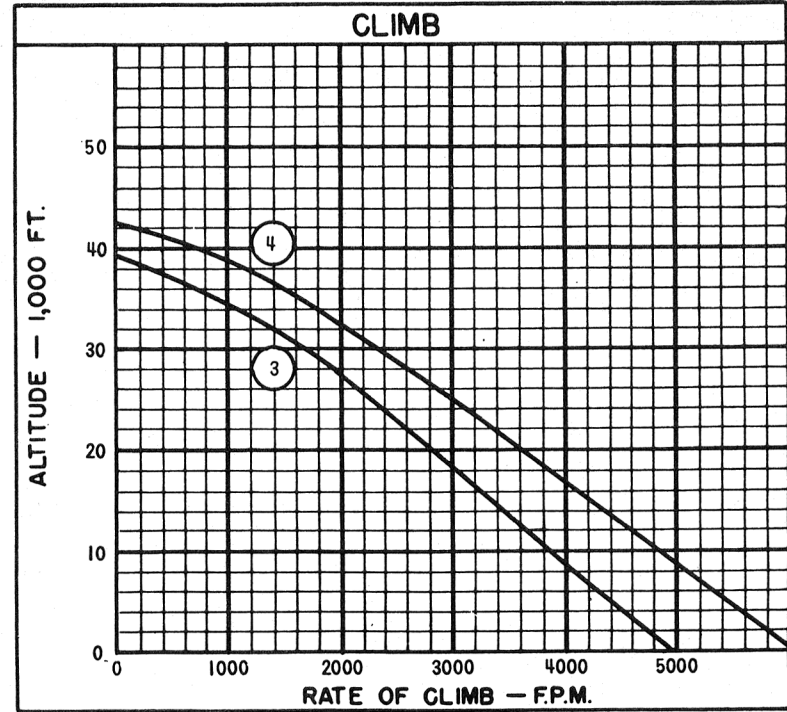
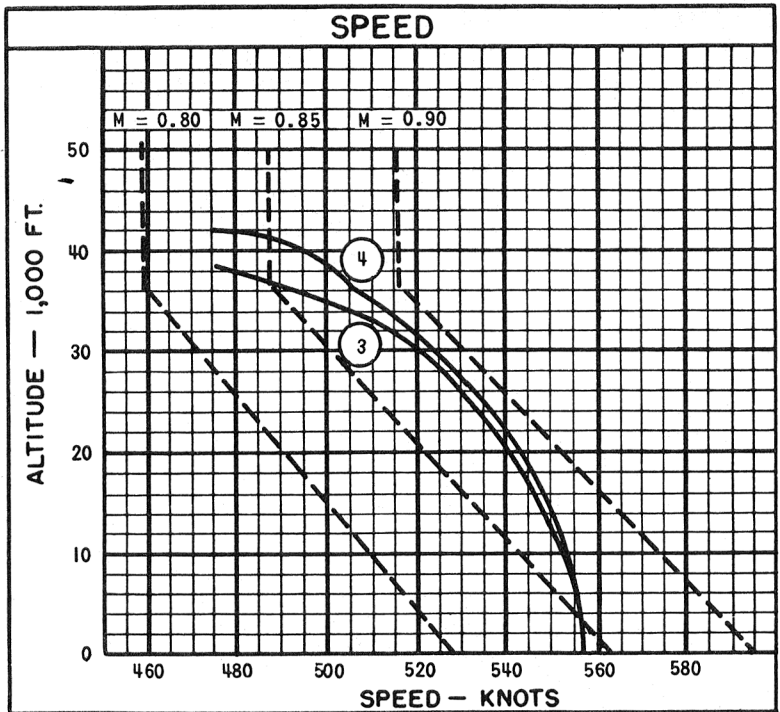

○ DENOTES LOADING CONDITION COLUMN NUMBER

CARRIER SUITABILITY

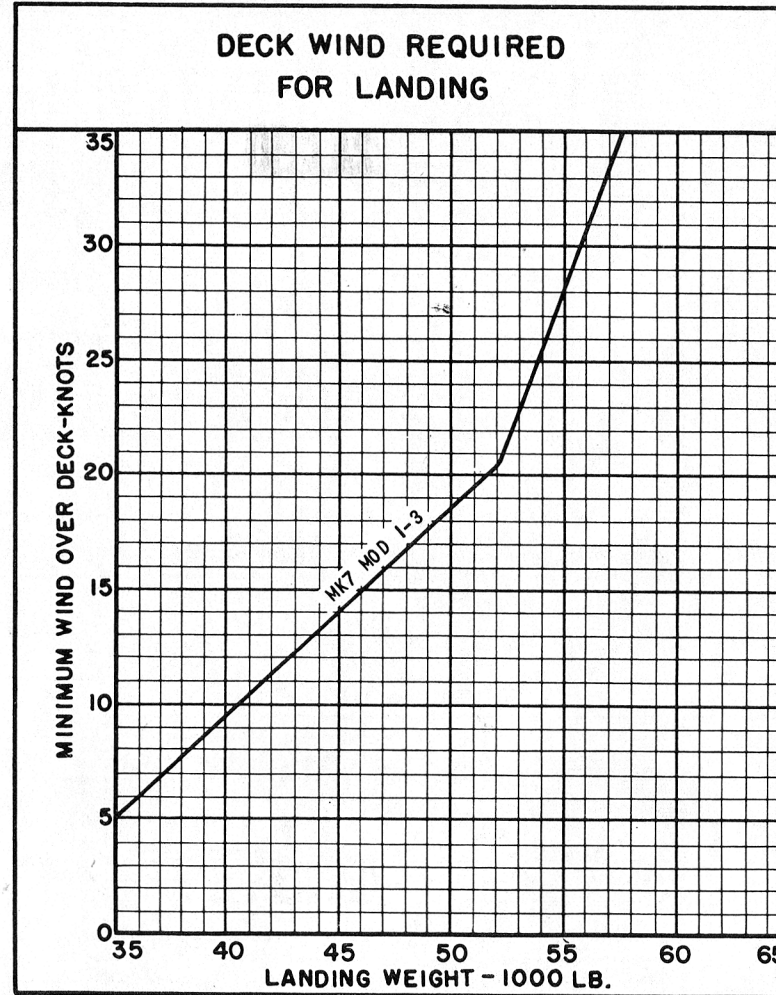
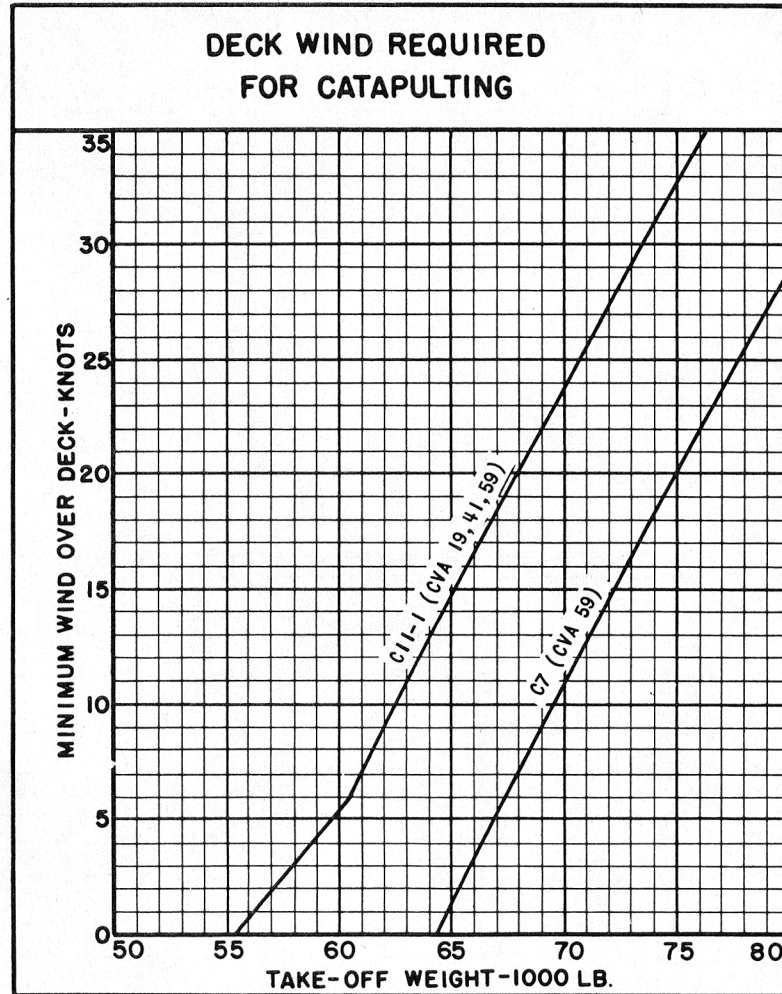

Catapult take-off speed is based on Launching Bulletin No. 6-49.

Approach speed is based on NATC recommended minimums

Catapult end speed limited by aircraft strength below 60,700 lbs. on C11 Catapult and below 64,200 lbs. on the C7 Catapult. Above these weights catapult end speed is limited by catapult capacity.

Engaging speed limited by airplane strength limit as determined by maximum rate of sink

DECLASSIFIED

NOTES

HIGH ALTITUDE RECONNAISSANCE MISSION

WARM UP, TAKE OFF, AND ACCELERATE: 5 minutes at normal thrust at sea level.

CLIMB: On course to optimum cruise altitude with military thrust.

CRUISE OUT: At altitudes and speeds for maximum range.

CLIMB: With maximum thrust on course to cruise ceiling.

RUN IN: 15 minutes at normal thrust at combat altitude

EVASIVE ACTION: 2 minutes at normal thrust at combat altitude (no distance gained)

ESCAPE: 8 minutes at normal thrust (assume escape ends at optimum cruise altitude)

CRUISE BACK: At altitudes and speeds for maximum range.

RESERVE: 20 minutes at sea level at speed for maximum endurance plus 5% of the initial fuel load

Combat Radius = climb + cruise out + climb + run in + escape + cruise back

Mission Time = time required for climb + cruise out + climb + run in + evasive action
+ escape + cruise back.

Loading Condition (3)

