

# STANDARD AIRCRAFT CHARACTERISTICS

A4D-1 "SKYHAWK"

DOUGLAS

Standard Aircraft Characteristics NAVAR 1335A (REV. 1-55)

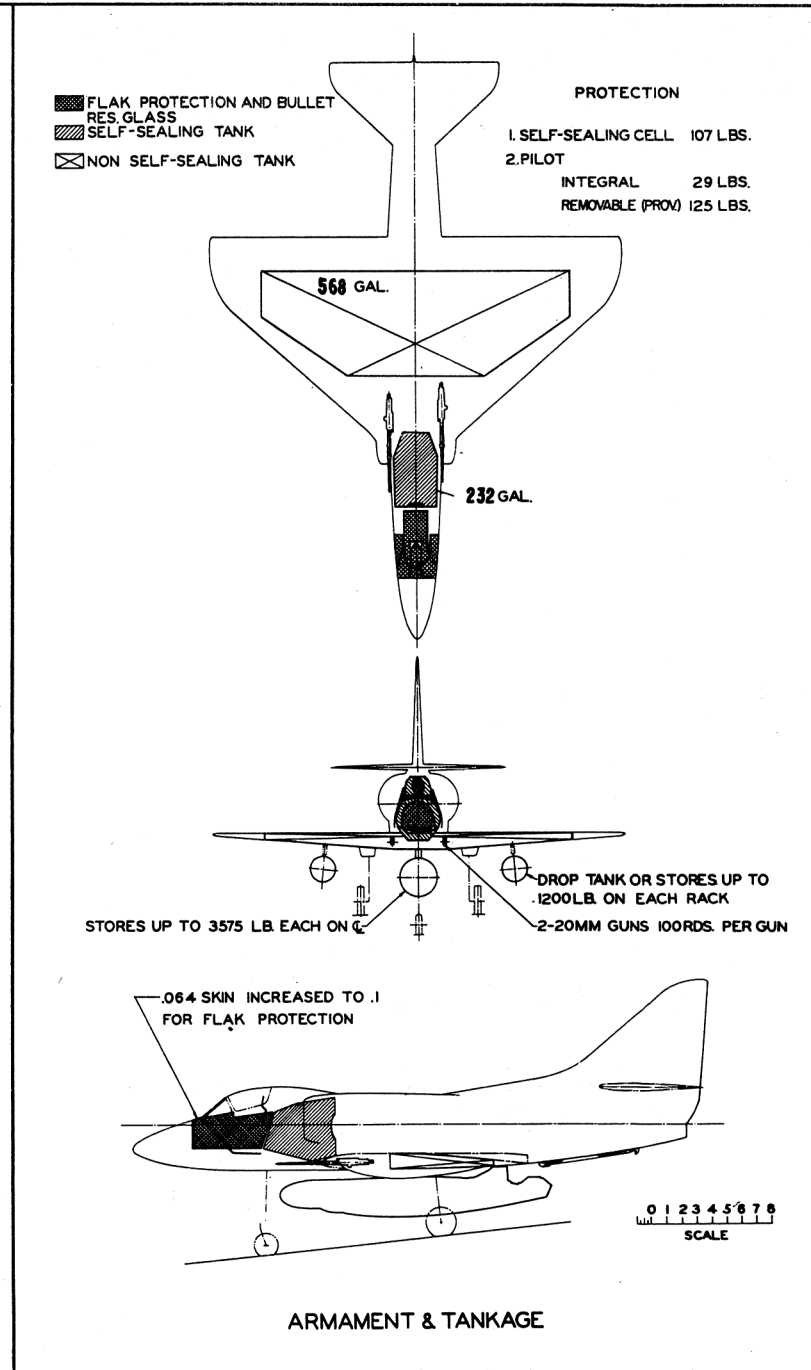
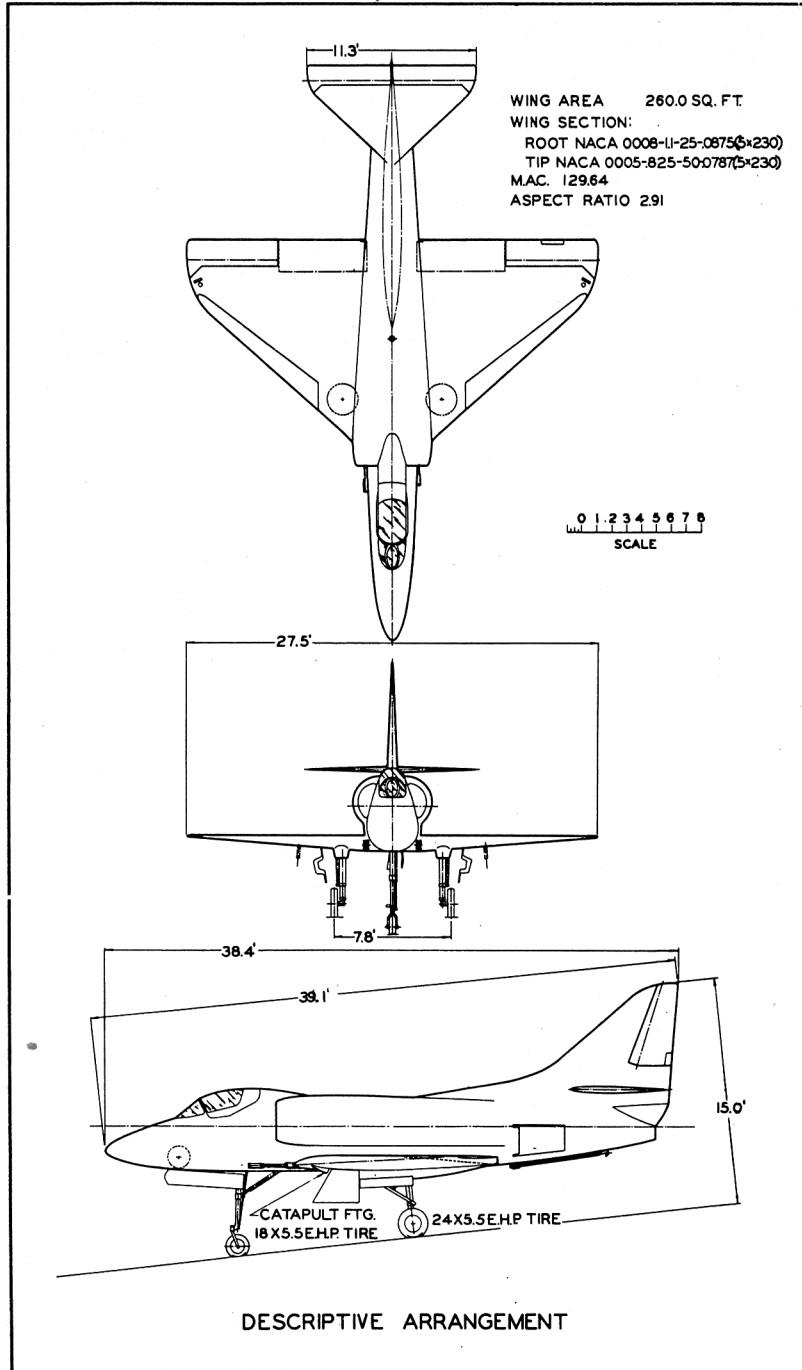

8

**POWER PLANT**

NO. & MODEL ..... (1) J65-W-4B  
 MFR.....Wright Aeronautical  
 TYPE.....Axial Flow  
 LENGTH .....113 in.  
 DIAMETER .....31 in.  
 AUGMENTATION ..... none

**RATINGS**

	LBS.	HPM
MILITARY	7000	8300
NORMAL	6780	8030

SEA LEVEL STATIC

SPEC. WAD N890-B

**MISSION AND DESCRIPTION**

The A4D-1 airplane is a light-weight, carrier based, jet attack airplane whose primary mission is the destruction of enemy ground and surface targets.

The arrangement is conventional with all-metal semi-monocoque structure and three-spar low aspect-ratio wing. Landing gear, flaps and speed-brakes are hydraulically operated. An electrically operated, fully adjustable stabilizer is used to trim throughout the normal flight range. The aileron, elevator, and rudder systems are hydraulic-power operated. Manual control is provided for emergencies. This airplane does not have folding wings nor provisions for inflight refueling.

**DEVELOPMENT**

First Flight.....August 1954  
 Service Use ..... October 1956

**WEIGHTS**

LOADINGS	LBS	L.F.
EMPTY	8400	
BASIC	8835	
DESIGN	12504	7.0
COMBAT	14826	5.9
MAX. T.O. (Field)	20000	4.2
(Cat.)	20000	4.2
MAX. LAND (Field)	16000	5.5
(Arrest)	12000	7.0

All weights are actual

**FUEL AND OIL**

NO. TANKS	TOL. GALS	LOCATION
1	568	Wing
1	232	Fuselage
2	300	Wing PLYONS

FUEL GRADE .....JP-4 or 5  
 FUEL SPEC (applicable).....MIL-F-5624

**OIL**

CAPACITY (gals).....2.8  
 SPEC (applicable).....MIL-L-7808

**ORDNANCE**

Maximum Bomb Capacity: 5975 lbs.

FUSELAGE

- Bombs
  - 1-Mk.81 Mod. 1 (250 lb.)
  - 1-Mk.82 Mod. 1 (500 lb.)
  - 1-Mk-83 Mod. 2 or 3 (1000 lb.)
  - 1-Mk.84 Mod. 1 (2000 lb.)
- Stores
  - 1-1660 lb.
  - 1-3250 lb.
  - 1-1050 lb.
  - 1-2025 lb.
  - 1-3500 lb.
- Spray Tank 1-Aero L4B
- Fire Bomb 1-Mk.79 Mod. 0 (1000 lb.) or 1-150 gal. DAC
- Fuel Tank
- Pyrotechnics 1-Aero 5A Flare Dispenser
- Radio 1-NAV PAC unit
- Rockets
  - 1-pkg. (7) 2.75" Aero 3A
  - 1-pkg. (19) 2.75" Aero X7A
  - 1-pkg. (4) 5.00" Aero X10A
- Prac. Bombs 1-Aero 5A prac. bomb cont.
- Drop Tanks
  - 1-150 gal. (DAC) (2 fins)
  - 1-300 gal. (DAC) (no fins)

(Continued on NOTES page)

**DIMENSIONS**

WING  
 AREA.....260 sq. ft.  
 SPAN.....27' - 6"  
 MAC.....10' - 9.6"  
 SWEEPBACK (1/4 chord).....33.2°  
 LENGTH.....39' - 1"  
 HEIGHT.....15' - 0"  
 TREAD.....7' - 9.6"

**ELECTRONICS**

Electr. Cont..... AN/ASQ-17  
 Integrated Package consisting of:  
 UHF Communication .....AN/ARC-27A  
 IFF.....AN/APX-5B  
 Coder.....AN/APA-89  
 Direction Finder .....AN/ARA-25  
 TACAN .....AN/ARN-21

External Stores

Marker-Beacon  
 Rec. AN/ARN-12  
 VOR Rec. AN/ARN-14E

Standard Aircraft Characteristics NAVAER-1335C (Rev. 1-55)

PERFORMANCE SUMMARY						
TAKE-OFF LOADING CONDITION	(1) LOW ALT. ATTACK 1-1050 LB. STORE 2-150 GAL. EXT. TANKS	(3) SEA LEVEL STORE DELIVERY 1-1050 LB. STORE 2-150 GAL. EXT. TANKS	(5) SEA LEVEL STORE DELIVERY 1-2025 LB. STORE	(7) SEA LEVEL STORE DELIVERY 1-3500 LB. STORE 2-150 GAL. EXT. TANKS	(9) SEA LEVEL STORE DELIVERY 2-500 LB. STORES 1-1000 LB. STORE	
TAKE-OFF WEIGHT	lb.	18,128	18,128	16,851	20,578	16,826
Fuel Internal/External (JP-5)	lb./lb.	5440/2040	5440/2040	5440/None	5440/2040	5440/None
Fayload	lb.	1050	1050	2025	3500	2000
Wing loading	lb./sq.ft.	69.7	69.7	64.8	79.1	64.7
Stall speed - power-off	kn.	121	121	115	129	117
Take-off run at S.L. - calm (A)	ft.	3050	3050	2550	4270	2550
Take-off run at S.L. 25 kn. wind (A)	ft.	2150	2150	1850	3100	1845
Take-off to clear 50 ft. - calm (A)	ft.	3840	3840	3350	5420	3340
Max. speed/altitude (A)	kn./ft.	545/6000	545/6000	565/S.L.	544/6000	564/S.L.
Rate of climb at S.L. (A)	fpm.	6740	6740	7800	5750	7805
Time: S.L. to 20,000 ft. (A)	min.	3.9	3.9	3.3	4.6	3.3
Time: S.L. to 30,000 ft. (A)	min.	7.1	7.1	5.8	8.7	5.8
Service ceiling (100 fpm) (A)	ft.	38,500	38,500	40,450	35,850	40,450
Combat range	n.mi.	1365	1365	890	1150	890
Average cruising speed	kn.	410	410	405	410	405
Cruising altitude(s)	ft.	33,100-40,700	33,100-40,700	34,400-39,300	30,300-36,700	34,400-39,300
Combat radius / Mission time (B)	n.mi./hr.	575/2.9	410/2.1	175/0.8	385/1.9	175/0.8
Average cruising speed	kn.	410	410	410	410	410
15,000 ft. store delivery radius/mission time	n.mi./hr.	625/3.1	625/3.1	395/2.0	575/2.9	395/2.0
COMBAT LOADING CONDITION	(2) TANKS OFF STORE RETAINED	(4) TANKS OFF STORE RELEASED	(6) STORE RETAINED	(8) TANKS OFF STORE RETAINED	(10) STORES RETAINED	
COMBAT WEIGHT	lb.	15,876	14,826	14,675	18,326	14,650
Engine power		MILITARY	MILITARY	MILITARY	MILITARY	MILITARY
Fuel	lb.	FULL INTERNAL	FULL INTERNAL	60% INTERNAL	FULL INTERNAL	60% INTERNAL
Combat speed/altitude	kn./M/ft.	566/.86/S.L.	577/.87/S.L.	565/.85/S.L.	567/.86/S.L.	565/.85/S.L.
Rate of climb/altitude	fpm/ft.	8400/S.L.	9350/S.L.	9145/S.L.	7120/S.L.	9150/S.L.
Combat ceiling (500 fpm)	ft.	40,800	42,450	42,350	37,800	42,200
Rate of climb at 15,000 ft.	fpm.	5850	6620	6400	4880	6405
Max. speed at 15,000 ft.	kn./M.	558/.89	566/.90	557/.89	557/.89	557/.89
Max. speed/altitude	kn./M/ft.	566/.86/S.L.	577/.87/S.L.	565/.85/S.L.	567/.86/S.L.	565/.85/S.L.
Max. speed at 35,000 ft.	kn./M	516/.89	525/.91	518/.90	506/.88	518/.90
LANDING WEIGHT	lb.	10,548	10,548	10,445	10,548	10,445
Fuel	lb.	1162	1162	1059	1162	1059
Stall speed - power-off /appr. pwr.	kn./kn.	90.9/86.7	90.9/86.7	90.5/86.3	90.9/86.7	90.5/86.3
Distance-grnd.run/over, 50 ft. obstacle	ft./ft.	2520/3235	2520/3235	2490/3205	2520/3235	2490/3205

## NOTES

PERFORMANCE BASIS: Contractor and NATC Flight Test Results

RANGE AND/OR RADIUS are based on NATC Flight test fuel consumption data.

A. Military Rated Thrust

B. For Effect of JP-4 Fuel on Combat Radius and Mission Time see Notes Page

All configurations include wing pylons, Guns and Ammunition

MISSION TIME: Any time where fuel is used and distance gained plus combat time.

SPOTTING: A total of 106 aircraft can be accommodated in a landing spot on the flight and hanger decks of a CVA-19 class angled deck carrier.

NAVIER-1335D (Rev. 1-55)

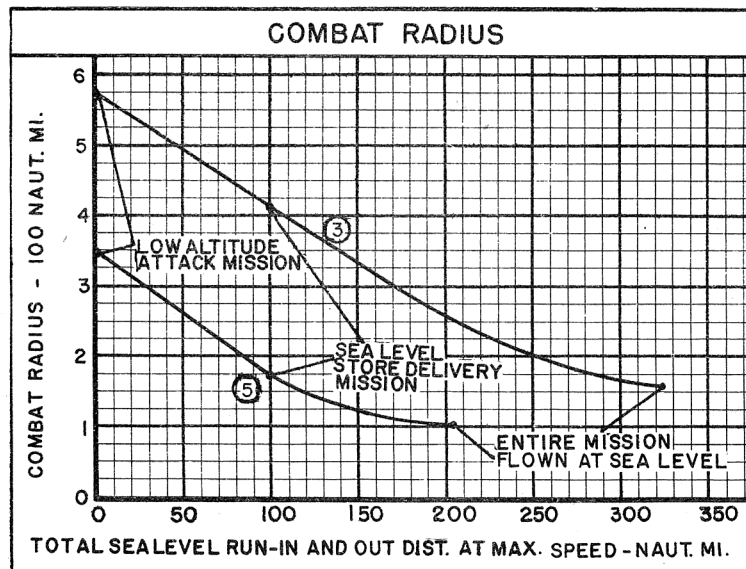
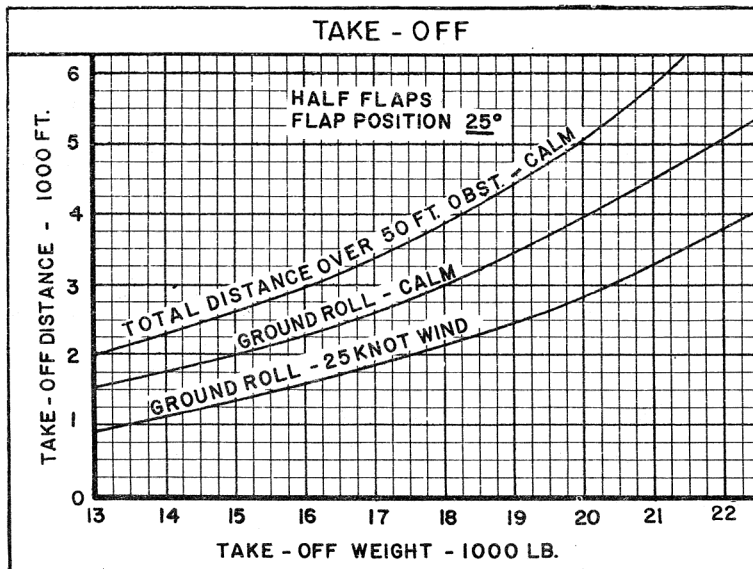
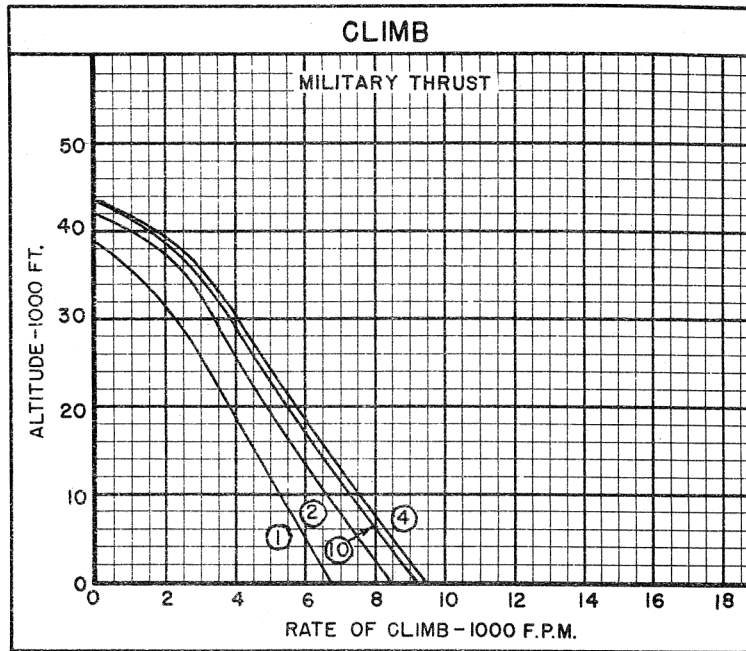
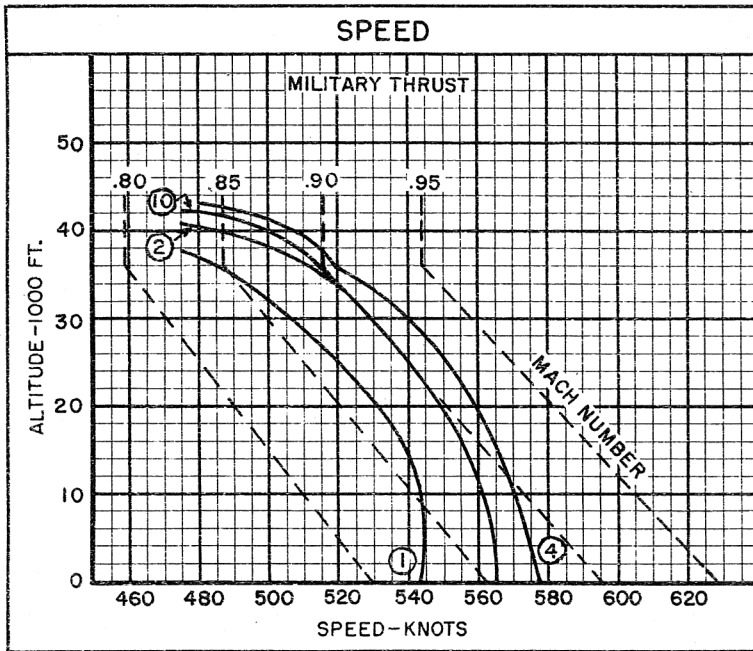

○ LOADING CONDITION COLUMN NUMBER

Standard Aircraft Characteristics NAVAER 1335E (Rev. 1-55)

# NOTES

**LOADING**  
(All data based on JP-4 fuel)

1-1050 lb. store plus 2-150 gal.ext.tanks	17,798 lb.
1-3500 lb. store plus 2-150 gal.ext.tanks	20,248 lb.
2-500 + 1-1000 lb. stores	16,586 lb.

**TAKE-OFF**  
**WEIGHT**

17,798 lb.
20,248 lb.
16,586 lb.

**15,000 FT. STORE DELIVERY**  
**Combat Radius      Mission Time**

590 n.mi.	3.0 hrs.
540 n.mi.	2.7 hrs.
365 n.mi.	1.9 hrs.

**SEA LEVEL STORE DELIVERY**  
**Combat Radius      Mission Time**

375 n.mi.	1.9 hrs.
345 n.mi.	1.8 hrs.
145 n.mi.	0.7 hrs.

**LOW ALTITUDE ATTACK**

START ENGINE, TAKE-OFF AND ACCELERATE: 5 minutes, with normal power at sea level.  
 CLIMB-OUT: Maximum rate of climb, military power on course to optimum cruise altitude.  
 CRUISE-OUT: Maximum range airspeeds at optimum cruise altitude. (Drop tanks when empty).  
 DESCEND: To S.L. (no fuel consumed - no distance covered) drop bombs, fire rockets.  
 COMBAT: At S.L. 5 minutes, military power. No distance made good.  
 CLIMB-BACK: At max. rate of climb, military power on course to optimum cruise altitude.  
 CRUISE-BACK: At maximum range airspeeds at optimum cruise altitude.  
 DESCEND: To sea level (no fuel consumed - no distance covered)  
 RESERVE: 5% initial fuel plus 20 min. at speed for maximum endurance at sea level.

**SEA LEVEL STORE DELIVERY**

START ENGINE, TAKE-OFF AND ACCELERATE: 5 minutes, normal power at sea level  
 CLIMB-OUT: Maximum rate of climb, military power on course to optimum cruise altitude.  
 CRUISE-OUT: Maximum range airspeeds at optimum cruise altitude. (Drop tanks when empty).  
 DESCEND: To S.L. (no fuel consumed - no distance covered).  
 RUN-IN: At S.L. for 50 n.mi. at max. speed with military power. Drop bombs, fire rockets.  
 COMBAT: At S.L. 5 minutes, military power. No distance made good.  
 RUN-OUT: At S.L. for 50 n.mi. at maximum speed with military power.  
 CLIMB-BACK: At maximum rate of climb, military power on course to optimum cruise altitude.  
 CRUISE-BACK: At maximum range airspeeds at optimum cruise altitude.  
 RESERVE: 5% initial fuel plus 20 minutes at speed for maximum endurance at sea level.

**15,000 FT. STORE DELIVERY**

START ENGINE, TAKE-OFF AND ACCELERATE: 5 minutes with normal power at sea level  
 CLIMB-OUT: Maximum rate of climb, military power on course to optimum cruise altitude  
 CRUISE-OUT: Maximum range airspeeds at cruise altitude. (Drop tanks when empty).  
 DESCEND: To 15,000 ft. (no fuel consumed-no distance covered) drop bombs, fire rockets.  
 COMBAT: 15,000 ft. for 5 min. with mil. power. No dist. made good.  
 CLIMB-BACK: Maximum rate of climb, military power on course to optimum cruise altitude.  
 CRUISE-BACK: Maximum range airspeeds at optimum cruise altitude.  
 DESCEND: To S.L. (no fuel consumed - no distance covered)  
 RESERVE: 5% initial fuel plus 20 minutes at speed for maximum endurance at sea level.

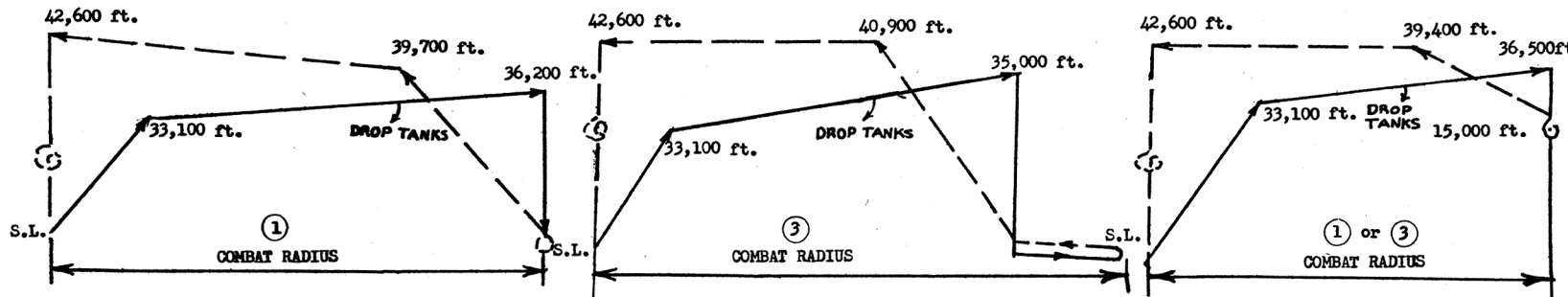

**ORDNANCE (Continued)**

<b>WING</b>	
Bombs	2-Mk.81 Mod. 1 (250 lb.) 2-Mk.82 Mod. 1 (500 lb.) 2-Mk.83 Mod. 2 or 3 (1000 lb.)
Drop Tank	2-150 gal. DAC (2 fins)
Fire Bomb	2-Mk. 79 Mod. 0 or 2-150 gal. DAC fuel tanks

Pyrotechnics	2-Aero 5A Flare Dispensers
Rockets	2-pkgs. (7) 2.75" Aero 3A 2-pkgs. (19) 2.75" Aero X7A 2-pkgs. (4) 5.00" Aero X10A
Mines	2-XG-3A (1000 lb.) 2-Mk.50 (500 lb.)

**FIXED GUNS/RDS. AMM.**  
2 Mk.12 Mod.0 20mm/100 rds. per gun

○ LOADING CONDITION COLUMN NUMBER

Standard Aircraft Characteristics NAVAR 1335F (Rev. 1-55)