

NAVAIR 00-110AA4-5

Standard Aircraft Characteristics

NAVY MODEL TA-4E AIRCRAFT

THIS PUBLICATION SUPERSEDES NAVAIR 00-110A-1 DATED
1 MAY 1955 IN PART AND ALL ADDENDA THERETO

PUBLISHED BY DIRECTION OF THE
COMMANDER OF THE NAVAL AIR SYSTEMS COMMAND

1 JULY 1967

NAVAIR OO-110AA4-5

Reproduction for non-military use of the information or illustrations contained in this publication is not permitted without specific approval of the issuing service (NAVAIR or USAF). The policy for use of Classified Publications is established for the Air Force in AFR 205-1 and for the Navy in Navy Regulations, Article 1509.

LIST OF CHANGED PAGES ISSUED

INSERT LATEST CHANGED PAGES. DESTROY SUPERSEDED PAGES.

NOTE: The portion of the text affected by the current change is indicated by a vertical line in the outer margins of the page.

* The asterisk indicates pages changed, added or deleted by the current change.

ADDITIONAL COPIES OF THIS PUBLICATION MAY BE OBTAINED AS FOLLOWS:

NAVAIR

ASAF ACTIVITIES.—In accordance with Technical Order No. 00-5-2.

NAVY ACTIVITIES.—Use DD FORM 1348 and submit in accordance with the instructions contained in NAVSUP PUBLICATION 437—Military Standard Requisitioning and Issue Procedures.

For information on other available material and details of distribution refer to NAVSUP PUBLICATION 2002, SECTION VIII and NAVAIR 00-500A.

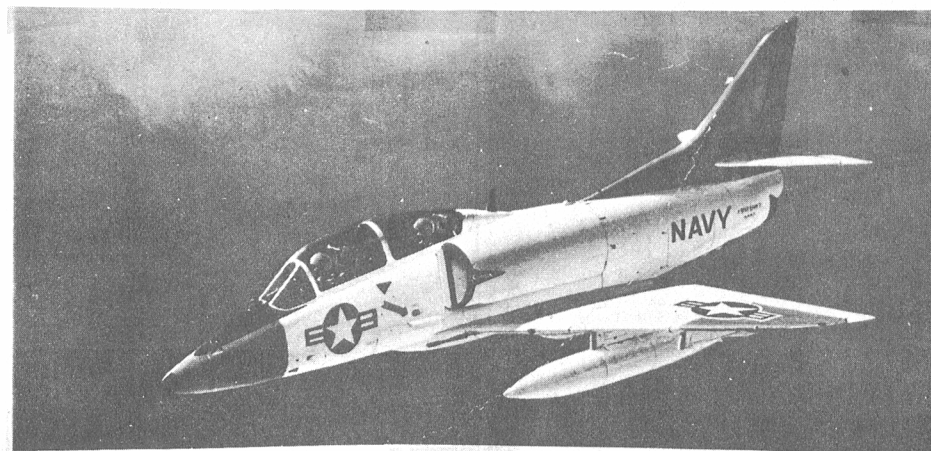

STANDARD AIRCRAFT CHARACTERISTICS

MODEL TA-4E

BUREAU OF NAVAL WEAPONS
NAVY DEPARTMENT

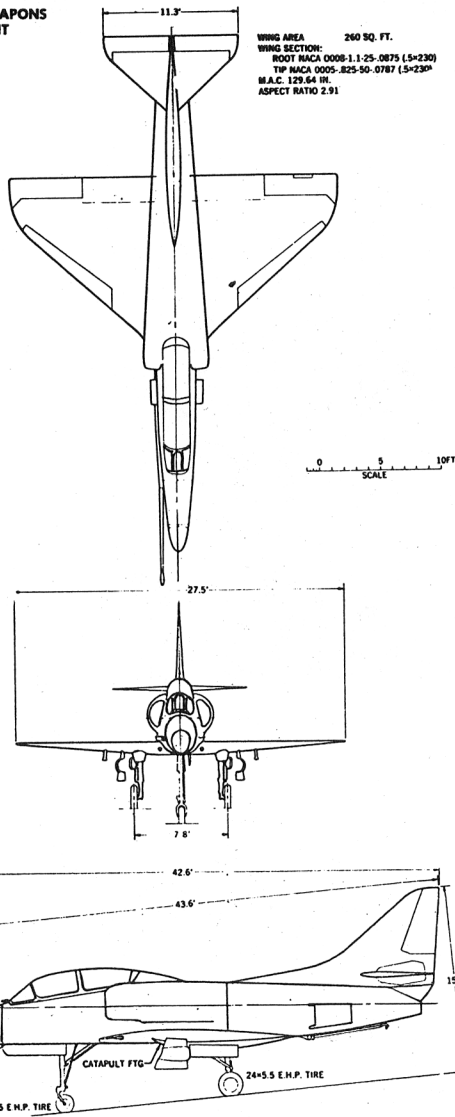

DESCRIPTIVE ARRANGEMENT

BUREAU OF NAVAL WEAPONS
NAVY DEPARTMENT

- BULLET RESISTANT GLASS
- SELF-SEALING TANK
- NON-SELF-SEALING TANK

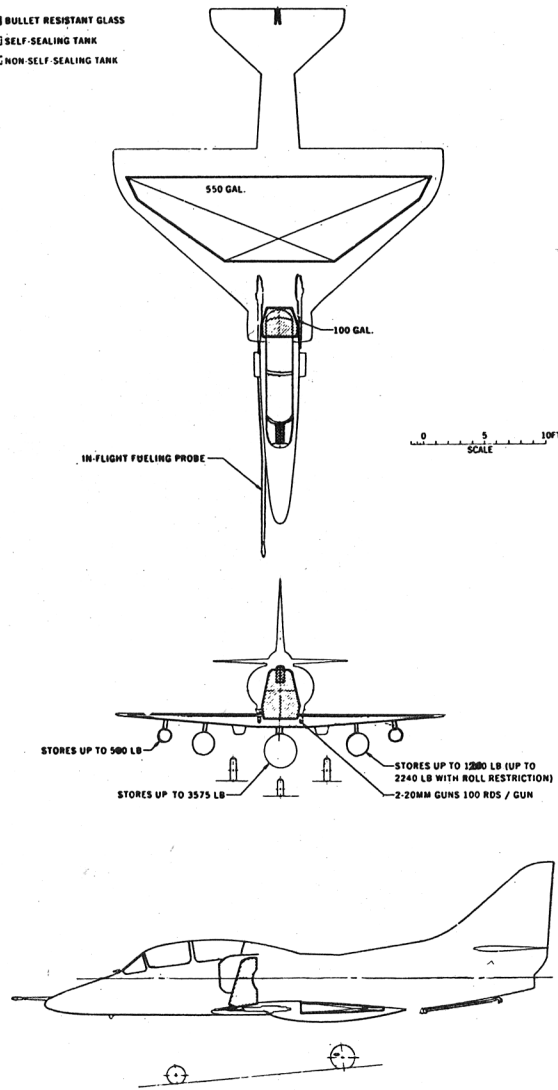

ARMAMENT AND TANKAGE

POWER PLANT	MISSION AND DESCRIPTION	WEIGHTS																																			
<p>No. & Model (1) J52-P-8A Axial Flow Twin Spool Turbojet Without Afterburner MFR. - P & W Aircraft Spec. No. N-1844</p> <p>Length116.9 in. Diameter.....30.2 in.</p> <p style="text-align: center;">RATINGS</p> <table border="0"> <tr> <td>MIL.</td> <td>12,060</td> <td>RPM</td> <td>9300 lb.</td> </tr> <tr> <td>Norm.</td> <td>11,660</td> <td>RPM</td> <td>8200 lb.</td> </tr> </table>	MIL.	12,060	RPM	9300 lb.	Norm.	11,660	RPM	8200 lb.	<p>The TA-4E is a two-seat advanced jet trainer version of the A-4E airplane. Missions include training of pilots in combat aerobatics, tactical maneuvers, instrument flying, carrier take-off and landing, and air-to-air and air-to-surface weapon delivery.</p> <p>The space for the second cockpit is obtained by moving the nose section of the basic A-4E forward 28 inches and reducing the size of the fuselage fuel tank. The nose landing gear is moved forward with the nose section. The rear seat is elevated above the forward seat for good visibility. Controls and instruments are repeated in the rear cockpit. Nose wheel steering and wing landing spoilers are installed. The J52-P-6A used in the A-4E.</p>	<table border="0"> <thead> <tr> <th>LOADINGS</th> <th>LEBS</th> <th>L.F.</th> </tr> </thead> <tbody> <tr> <td>Empty</td> <td>10,602</td> <td></td> </tr> <tr> <td>Basic</td> <td>10,781</td> <td></td> </tr> <tr> <td>Flight Design</td> <td>12,504</td> <td>7.0</td> </tr> <tr> <td>Combat</td> <td>18,541</td> <td>4.7</td> </tr> <tr> <td>Max. Take-Off</td> <td>24,500</td> <td>3.6</td> </tr> <tr> <td>Max. Landing</td> <td></td> <td></td> </tr> <tr> <td> Arrest</td> <td>14,500</td> <td>6.0</td> </tr> <tr> <td> Airfield</td> <td>16,000</td> <td>5.5</td> </tr> </tbody> </table>	LOADINGS	LEBS	L.F.	Empty	10,602		Basic	10,781		Flight Design	12,504	7.0	Combat	18,541	4.7	Max. Take-Off	24,500	3.6	Max. Landing			Arrest	14,500	6.0	Airfield	16,000	5.5
MIL.	12,060	RPM	9300 lb.																																		
Norm.	11,660	RPM	8200 lb.																																		
LOADINGS	LEBS	L.F.																																			
Empty	10,602																																				
Basic	10,781																																				
Flight Design	12,504	7.0																																			
Combat	18,541	4.7																																			
Max. Take-Off	24,500	3.6																																			
Max. Landing																																					
Arrest	14,500	6.0																																			
Airfield	16,000	5.5																																			
ELECTRONICS		FUEL AND OIL																																			
<p>UHF Communications AN/ARC-51A IFF AN/APX-64 Standby Communications AN/ARR-69 DIRECT FINDER AN/ARA-5C TAGAN AN/ARN-52 Labs (Gyro and Loft Mode) AN/AJB-3A Auto Pilot DOUGLAS Store Arming AN/AWW-1</p> <p>Radar AN/APG-53A Radar Altimeter AN/APN-141 Doppler AN/APN-153 Auto. Dead Reckon AN/ASN-41 Air Data Computer and Bombing Mode of AJB-3A Shrike and BULLPUP Provisions</p>	DEVELOPMENT	<table border="0"> <thead> <tr> <th>Gal.</th> <th>No. Tanks</th> <th>Location</th> </tr> </thead> <tbody> <tr> <td>560</td> <td>1</td> <td>Wing</td> </tr> <tr> <td>100</td> <td>1</td> <td>Fuselage</td> </tr> </tbody> </table> <p>In-flight fueling is installed Fuel Spec MIL-J-5624E</p> <p style="text-align: center;">OIL</p> <p>5.0 Gal. mounted on engine Oil Spec MIL-L-23699</p>	Gal.	No. Tanks	Location	560	1	Wing	100	1	Fuselage																										
Gal.	No. Tanks	Location																																			
560	1	Wing																																			
100	1	Fuselage																																			
	DIMENSIONS	ORDNANCE																																			
	<p>Span27.5 ft. Length42.5 ft.* Height15.3 ft. Max. Tread 7.8 ft. Turn. Rad. 24.5 ft.* Wing Area 260 sq. ft.</p> <p>*Without in-flight fueling probe</p>	<table border="0"> <thead> <tr> <th>No.</th> <th>Location</th> <th>Loading</th> </tr> </thead> <tbody> <tr> <td>1</td> <td>Fuselage Center Line</td> <td>Up to 3575 lb.</td> </tr> <tr> <td>2</td> <td>Inboard Wing</td> <td>Up to 1200 lb.</td> </tr> <tr> <td>2</td> <td>Outboard Wing</td> <td>Up to 500 lb.</td> </tr> <tr> <td colspan="3" style="text-align: center;">No Roll Restriction</td> </tr> <tr> <td colspan="3" style="text-align: center;">-----</td> </tr> <tr> <td colspan="3" style="text-align: center;">GUNS</td> </tr> <tr> <td>2</td> <td>Lower Wing Outboard of Fuselage</td> <td>MK-12 20 mm Guns with 100 Rds. per Gun</td> </tr> </tbody> </table>	No.	Location	Loading	1	Fuselage Center Line	Up to 3575 lb.	2	Inboard Wing	Up to 1200 lb.	2	Outboard Wing	Up to 500 lb.	No Roll Restriction			-----			GUNS			2	Lower Wing Outboard of Fuselage	MK-12 20 mm Guns with 100 Rds. per Gun											
No.	Location	Loading																																			
1	Fuselage Center Line	Up to 3575 lb.																																			
2	Inboard Wing	Up to 1200 lb.																																			
2	Outboard Wing	Up to 500 lb.																																			
No Roll Restriction																																					

GUNS																																					
2	Lower Wing Outboard of Fuselage	MK-12 20 mm Guns with 100 Rds. per Gun																																			

PERFORMANCE SUMMARY

TAKE-OFF LOADING CONDITION	(1) Hi-Hi-Hi Clean Airplane	(3) Hi-Hi-Hi 2-300 Gal. Tanks	(5) S.L. Store Delivery 1 MK-28 Store 2-300 Gal. Tanks	(7) Close Support 1-300 Gal. Tank 12-MK 81 Snakeeyes	(9) Ferry 3-300 Gal.
TAKE-OFF WEIGHT	lb. 15,846	21,043	23,148	22,753	23,281
Fuel internal/external (JP-5)	lb./lb. 4488/None	4488/4080	4488/4080	4488/2040	4488/6120
Payload	lb. None	None	2040	3600	None
Wing loading	lb./sq. ft. 60.9	80.9	89.0	87.5	89.5
Stall speed—power-off	kn. 113	133	139	139	139
Take-off run at S.L.— calm (A)	ft. 1800	3410	4500	4270	4570
Take-off run at S.L.— 25 kn. wind (A)	ft. 1160	2390	3240	3060	3290
Take-off to clear 50 ft.— calm (A)	ft. 2980	5170	6590	6300	6680
Max. speed/altitude (A)	kn./ft. 582/S.L.	538/5,000	531/7,500	489/10,000	529/5,000
Rate of climb at S.L. (A)	fpm. 10,150	6500	5700	5200	5900
Time: S.L. to 20,000 ft. (A)	min. 2.6	4.6	5.5	6.2	5.1
Time: S.L. to 30,000 ft. (A)	min. 4.4	9.1	12.5	16.8	10.9
Service ceiling (100 fpm) (A)	ft. 42,600	34,500	31,700	29,800	32,600
Combat range (Tanks Retained)	n.mi. 795	1280	1080	600	1490 (B)
Average cruising speed	kn. 433	415	413	389	410
Cruising altitude(s)	ft. 37,200 - 41,200	30,200 - 38,200	27,900 - 34,900	26,800 - 31,200	27,400 - 37,100
Combat radius/mission time	n.mi./hr. 360/1.8	655/3.2	420/2.0	125/1.6 (C)	--
Average cruising speed	kn. 433	420	420	402	--
IFR Radius/Mission Time	n.mi./hr. 640/3.1	--	--	--	--
IFR Fuel Transferred/Dist.	lb./n.mi. 2191/362	--	--	--	--
COMBAT LOADING CONDITION	(2) Clean Airplane	(4) Tanks Retained	(6) Tanks Dropped Store Retained	(8) Tank Dropped Stores Retained	(10) Tanks Retained
COMBAT WEIGHT	lb. 14,051	16,963	18,672	20,515	17,161
Engine power	MILITARY	MILITARY	MILITARY	MILITARY	MILITARY
Fuel	lb. 2693	4488	4488	4488	4488
Combat speed/combat altitude	kn./ft. 515/38,200	497/33,400	547/S.L.	503/5,000	524/S.L.
Rate of climb/combat altitude	fpm/ft. 2300/38,200	1800/33,400	7800/S.L.	5200/5000	8200/S.L.
Combat ceiling (500 fpm)	ft. 44,000	38,100	36,700	31,400	37,300
Rate of climb at S.L.	fpm. 11,550	8,500	7800	6150	8200
Max. speed at S.L.	kn. 582	537	547	491	524
Max. speed/altitude	kn./ft. 582/S.L.	541/7,500	554/7,500	504/12,500	532/6,500
LANDING WEIGHT	lb. 12,211	13,156	13,221	13,426	13,906
Fuel	lb. 853	1077	1077	1000	1233
Stall speed—power-off/approach power	kn./kn. 99/95	103/98	103/98	104/99	108/101
Landing distance—ground roll/over 50 ft. obst.	ft./ft. 2310/3025	2480/3195	2490/3205	2530/4245	2610/3325

- (A) Military Thrust, Take-Off Weight, Stores and Tanks Retained
 (B) Ferry Range is 1640 n.mi. if Tanks Dropped, When Empty.
 (C) Combat Radius is 130 n.mi. if Tanks Dropped When Empty.
 (D) All Loadings Except Clean Airplane Include Guns and Ammunition, and Have Pylons on all Stations.

NOTES

- (E) Data Basis: NATC and DAC Flight Tests of the Model A-4E and Pratt and Whitney Specification No. N-1844.

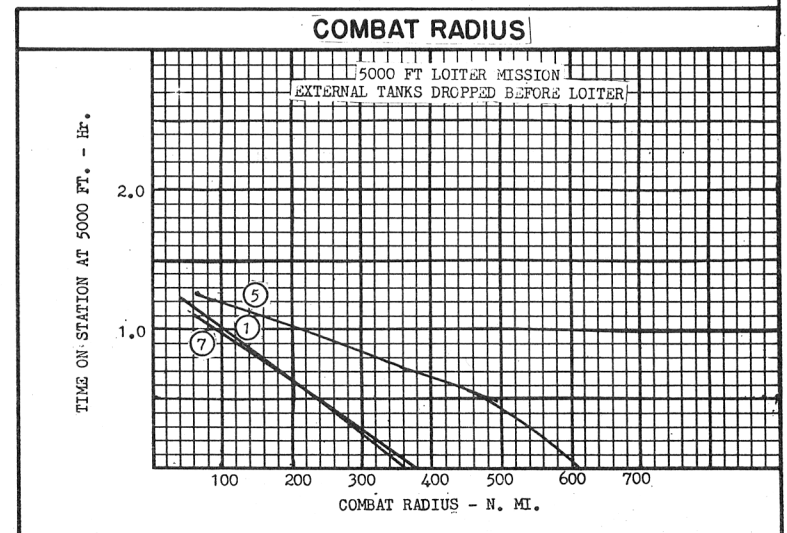
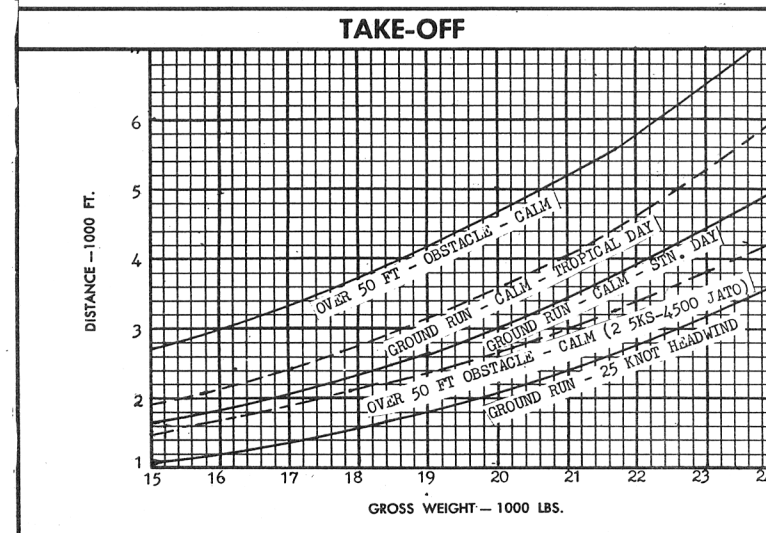
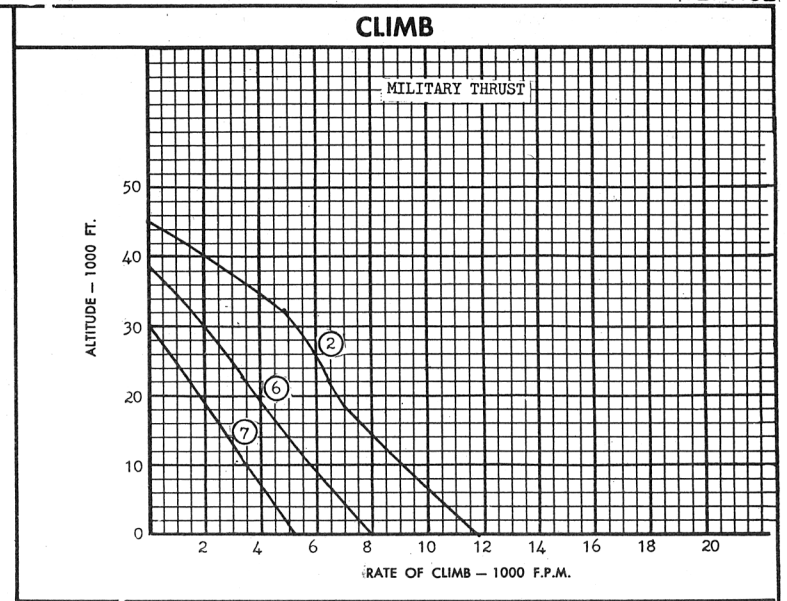
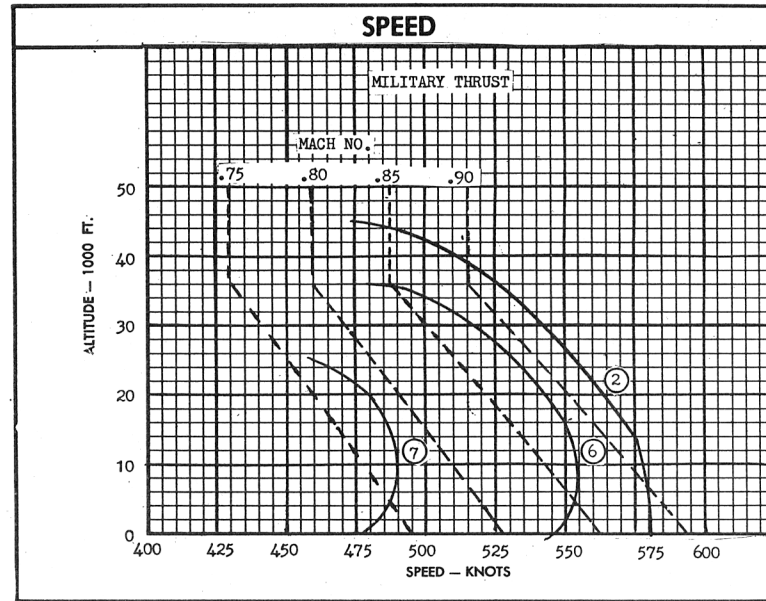

○ LOADING CONDITION COLUMN NUMBER

MINIMUM WIND OVER DECK REQUIRED FOR CATAPULTING
VS. GROSS WEIGHT (A) (B)

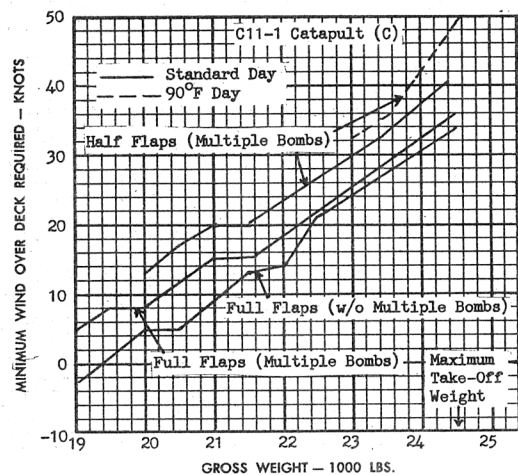

MINIMUM WIND OVER DECK REQUIRED FOR ARRESTING
VS. GROSS WEIGHT (D)

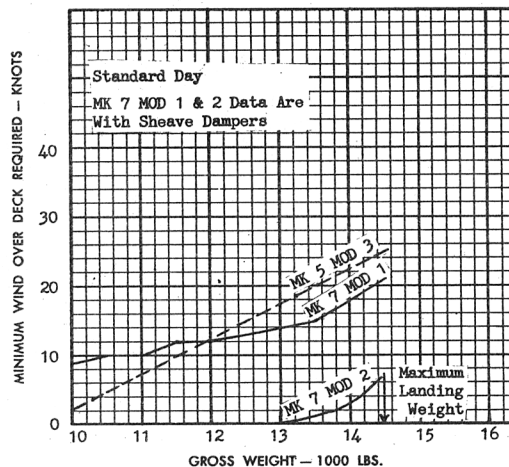

WAVE-OFF ACCELERATION

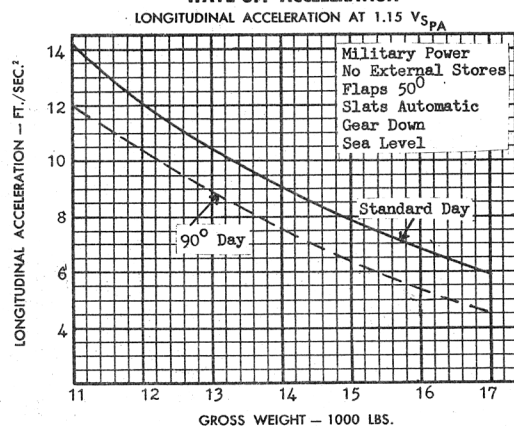

MINIMUM CARRIER APPROACH SPEEDS (E)

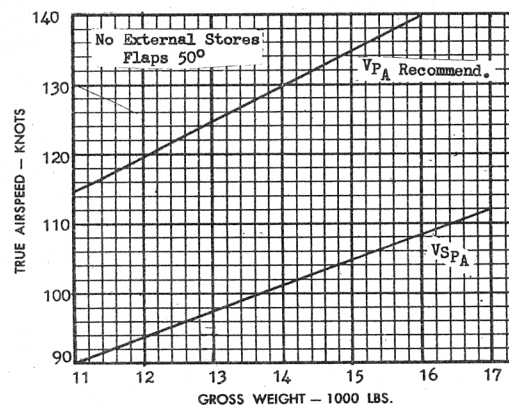

NOTES

- (A) Catapult Wind Over Deck Requirements are Estimated on the Basis of A-4E Aircraft/Catapult Flight Testing (Launch Bul. 6-36C, Figs 6 & 9)
- (B) Catapult End Speed is Limited by a Maximum Tow Force of 120,000 lb Above a Takeoff Weight of 22,500 lb on the C11-1 and C7 Catapults and a Maximum Longitudinal Acceleration of 5.47g Below 22,500 lb
- (C) Minimum Wind Over Deck Required for C7 Catapult is C11-1 Requirement Minus 12 Knots

- (D) Arrested Landing Wind Over Deck Requirements are Estimated on the Basis of A-4E Aircraft/Arresting Gear Flight Testing (Recovery Bul.: 21-12B, 24-13A & 26-12B)
- (E) Approach Speeds are Estimated on Speeds Recommended in A-4E Flight Handbk.
- (F) SPOTTING: A Total of 175 Airplanes can Be Accommodated in a Landing Spot on the Flight and Hanger Decks of a CVA-59 Class Carrier.

STORE LOADING

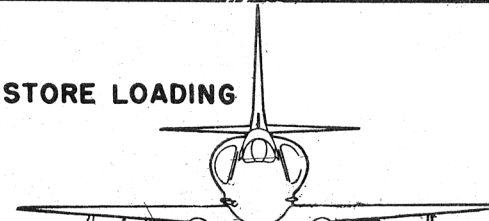

500 lb. 1200 lb. 3575 lb. 1200 lb. 500 lb.

ORDNANCE	(Station No. 5) OUTBOARD STATION	(Station No. 4) INBOARD STATION	(Station No. 3) FUSELAGE	(Station No. 2) RIGHT INBOARD	(Station No. 1) RIGHT OUTBOARD
BOMBS	--- 1) MK-81 1) MK-82 ---	1) MK-79 MOD 0 Fire Bomb 6) MK-81 1) MK-82 1) MK-83 ---	1) MK-79 MOD 0 Fire Bomb 6) MK-81 6) MK-82 1) MK-83 1) MK-84	1) MK-79 MOD 0 Fire Bomb 1) MK-81 1) MK-82 1) MK-83 ---	--- 1) MK-81 1) MK-82 ---
SPECIAL WEAPONS	---	---	1) MK-28 1) MK-43 1) MK-57	---	---
ROCKET LAUNCHERS	1) Aero 6A-1 1) LAU 3/A 1) LAU 10/A	1) Aero 6A-1 1) LAU 3/A 1) LAU 10/A	1) Aero 6A-1 1) LAU 3/A 1) LAU 10/A	1) Aero 6A-1 1) LAU 3/A 1) LAU 10/A	1) Aero 6A-1 1) LAU 3/A 1) LAU 10/A
GUIDED MISSILES	1) AGM-12B(BULLPUP A) --- 1) AGM-45A(SHRIKE)	1) AGM-12B(BULLPUP A) 1) AGM-12C(BULLPUP B) 1) AGM-45A(SHRIKE)	1) AGM-12B(BULLPUP A) --- ---	1) AGM-12B(BULLPUP A) 1) AGM-12C(BULLPUP B) 1) AGM-45A(SHRIKE)	1) AGM-12B(BULLPUP A) --- 1) AGM-45A(SHRIKE)
EXTERNAL FUEL TANKS	---	1) 150 Gal. 1) 300 Gal. ---	1) 150 Gal. 1) 300 Gal. 1) 300 Gal. Refuel. Tank	1) 150 Gal. 1) 300 Gal. ---	---
MISCELLANEOUS STORES	---	1) MK-4MOD1 Gun Pod --- ---	1) MK-4MOD1 Gun Pod 1) Aero 4B Spray Tnk. 1) AERO 1A 150 Gal Napalm Tank	1) MK-4MOD1 Gun Pod --- ---	---
MOUNTING/LAUNCHING DEVICES	---	1) Douglas A/A37B-1 MBR	1) Douglas A/A37B-1 MBR	1) Douglas A/A37B-1 MBR	---
NOTES: (A) Multiple Stores are Mounted on the Douglas MBR. Single Stores are Mounted on the Aero 7A Centerline Rack-Pylon and the Aero 20A Wing Rack-Pylon.			(B) Mounting/Launching Devices are Mounted on the Aero 7A Centerline Rack-Pylon and the Aero 20A Wing Rack-Pylon.		
			(C) Only Individual Station Maximum Capabilities are Listed.		

NOTES

HI-HI-HI

Warm-Up, Taxi, Take-Off: 5 Min S.L. NRP
 Climb: On Course to Optimum Cruise Altitude with Military Power
 Cruise Out: At Max Range Speed at Optimum Cruise Altitude (Drop Fuel Tanks When Empty)
 Combat: 5 Min at MRT (Stores on, No Distance Gained)
 Cruise Back: At Max Range Speed at Optimum Altitude.
 Reserve: 5% Initial Fuel + 20 Min at Maximum Endurance Speed at S.L.

SEA LEVEL STORE DELIVERY

Warm-Up, Taxi, Take-Off: 5 Min S.L. NRP
 Climb: On Course to Optimum Cruise Altitude with Military Power
 Cruise Out: At Max Range Speed at Optimum Cruise Altitude (Drop Fuel Tanks When Empty)
 Descend: To S.L. When 50 N.Mi From Target (No Fuel Used, No Distance Gained)
 Run In: 50 N.Mi at Vmax at MRT
 Combat: 5 Min at MRT (Stores On, No Distance Gained) Stores Dropped After Combat
 Run Out: 50 N.Mi at Vmax at MRT at S.L.
 Climb: On course to Optimum Cruise Altitude with Military Power
 Cruise Back: At Max Range Speed at Optimum Altitude
 Reserve: 5% Initial Fuel + 20 Min at Max Endurance Speed at S.L.

CLOSE SUPPORT

Warm-Up, Take-Off: 5 Min S.L. NRP
 Climb: On Course to Optimum Cruise Altitude with Mil. Power
 Cruise Out: At Max Range Speed at Optimum Altitude (Drop Fuel Tanks When Empty)
 Descend: To 5000' (No Fuel Used, No Distance Gained)
 Loiter: 1 Hour at Max Endurance Speed (No Distance Gained) Stores Dropped at End of Loiter'
 Climb: On Course to Optimum Cruise Altitude with Mil. Power
 Cruise Back: At Max Range Speed at Optimum Altitude
 Reserve: 5% Initial Fuel + 20 Min at Max Endurance Speed at S.L.

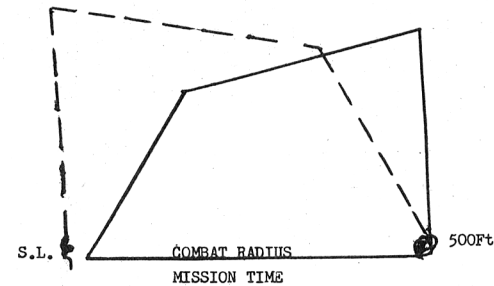
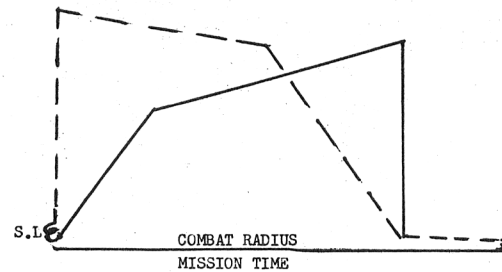
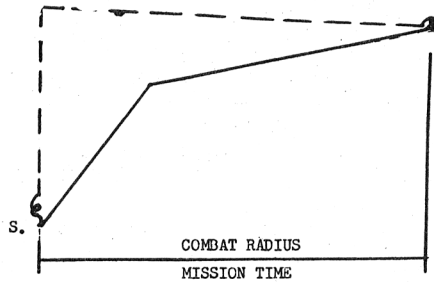

NOTE-
 Mission Time: Excludes Time for Warm-Up and Take-Off and 20 Min Loiter Time
 Cycle Time: Is Mission Time Plus 20 Min S.L. Loiter

○ LOADING CONDITION COLUMN NUMBER