

STANDARD AIRCRAFT CHARACTERISTICS

A-5C (A3J-3)

VIGILANTE

DECLASSIFIED

CLASSIFICATION (CANCELED) () BY AUTHORITY OF
 AIR-9603)
 ON 6-14-83 *O. H. Persons*
 (DATE) (SIGNATURE) (RANK)
 NAVAL AIR SYSTEMS COMMAND
 DEPARTMENT OF THE NAVY

CLEARED
 FOR OPEN PUBLICATION
 JUN 27 1983
 COMNAVAIRSYSCOM

A. W. Frascella
 Public Information Officer
 By direction of the Commander

NORTH AMERICAN AVIATION, INC.

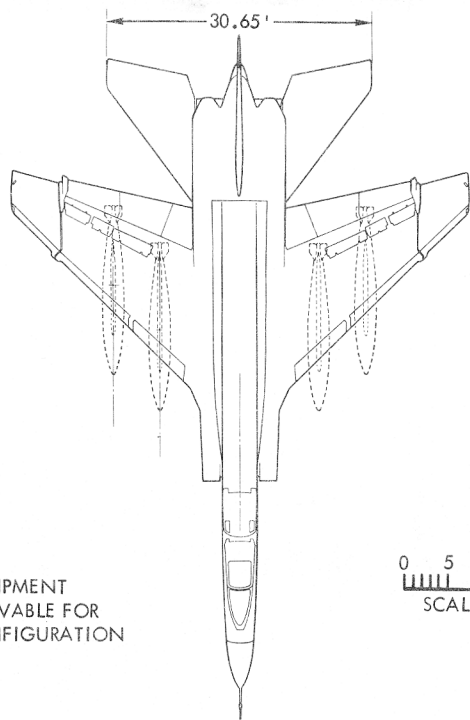

NOTE:
SPECIAL EQUIPMENT
POD IS REMOVABLE FOR
ATTACK CONFIGURATION

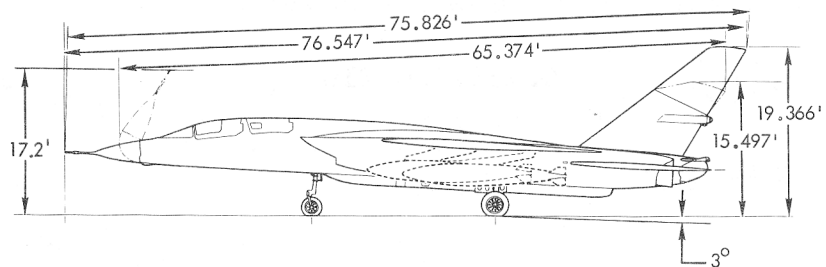
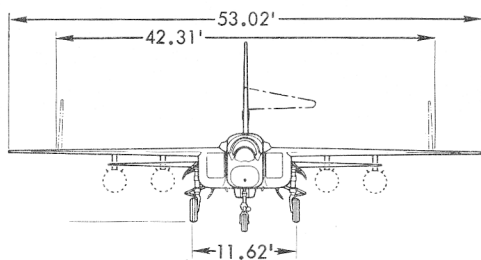
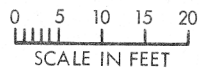

DESCRIPTIVE ARRANGEMENT

THREE FUEL TANKS TOTAL
885 GAL (INTERNAL)

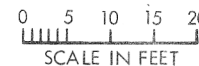
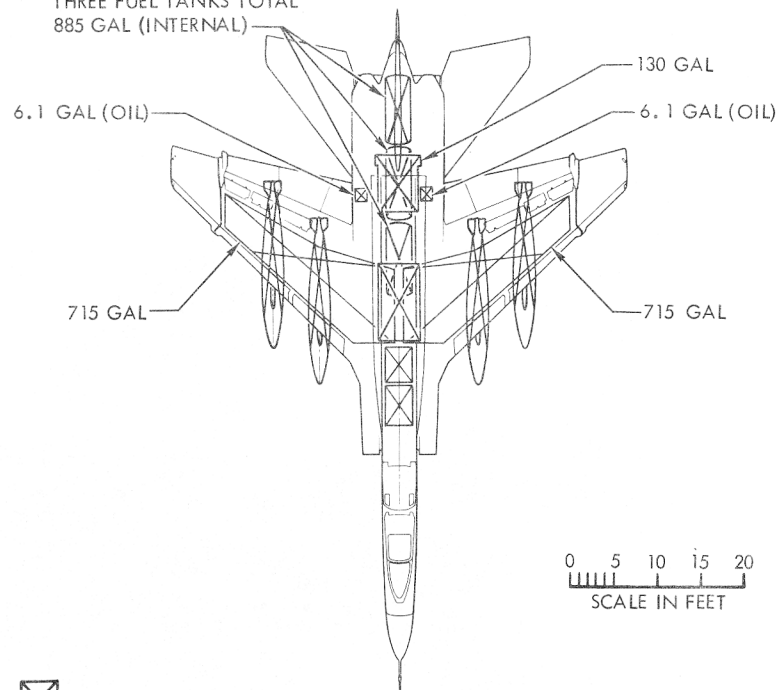

☒ NON-SELF-SEALING TANKS

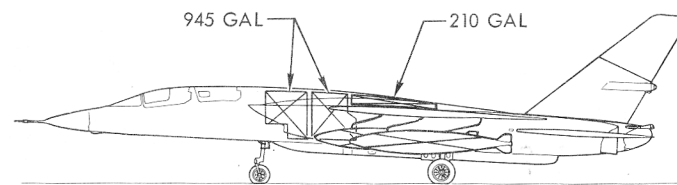
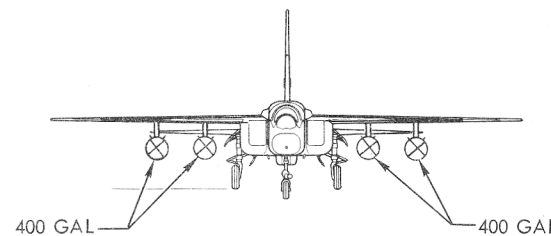

TANKAGE

POWER PLANT

NO. & MODEL (2) J79-GE-8
 MFR General Electric
 TYPE Axial Flow
 LENGTH 207.3 IN
 DIAMETER 31.6 IN
 AUGMENTATION A/B

RATINGS

	LBS	RPM
MAXIMUM	17,000	7685
MILITARY	10,800	7685
NORMAL	10,300	7385

STATIC SEA LEVEL
 SPEC. NO E763A

ORDNANCE

INTERNAL ARMAMENT

NO	DESCRIPTION
1	SPECIAL WEAPON MK-28
1	SPECIAL WEAPON MK-27
1	SPECIAL WEAPON MK-43

EXTERNAL ARMAMENT

NO	SIZE	DESCRIPTION
4		SPECIAL WEAPON MK-28
4		SPECIAL WEAPON MK-43
4	500 LB	G.P. MK-82
4	1000 LB	G.P. MK-83
4	2000 LB	G.P. MK-84

TRAINING

NO	DESCRIPTION
4	PRACTICE BOMB CONTAINER AERO 8A-1*

*CARRIES (16) MK-76'S OR MK-89'S OR MK-106'S

MISSION AND DESCRIPTION

The primary mission of the A-5C airplane is tactical reconnaissance of hostile areas from sea level or high altitudes by day or night regardless of weather or enemy defenses. Capabilities include photographic missions, attack/photographic missions, and electronic countermeasure missions. Alternate capabilities of the A-5C include the destruction of hostile land or sea targets from sea level or high altitudes by day or night.

The A-5C is an improved version of the A-5A (A3J-1) twin-engine, carrier-based, two-place attack bomber with increased radius of action and multi-sensor reconnaissance capabilities. Major improvements over the A-5A are: wing leading edge BLC, extended-span single-slotted trailing edge flaps, 500 gallon increased internal fuel capacity, added wing station for additional external fuel or armament carriage, increased braking capacity and increased engine inlet duct capture area to improve high altitude performance. Other special features of this airplane, similar to the A-5A are: swept-back wing (with droopable leading edges and spoiler-slot-deflector lateral controls), all moveable horizontal and vertical tails, irreversible hydraulic power with artificial feel for all controls, and a linear bomb bay with rearward weapon ejection to insure weapon separation at all possible speeds, release attitudes and altitudes.

The cockpits are provided with differential pressurization, automatic heating and cooling, anti-G suit provisions, jettisonable canopies, and advanced type ejection seats capable of sea level crew ejection.

DEVELOPMENT

FIRST FLIGHT PROTOTYPE #3 JUNE, 1962
 FIRST FLEET DELIVERY DATE OCTOBER, 1963

ELECTRONICS

AN/ASB-12 (XN-2) Inertial Bomb Nav Mapping Radar TV System Inertial Navigator Analog-Digital Computer	AN/ASN-26 Master Flight Reference System ICS - Intercommunications System AC Electrical Power System DECM - Electronic Countermeasures AN/ALQ-41, AN/ALQ-51 DECM System AN/ALQ-55 DECM System AN/APR-18 Passive Warning System Engine Inlet Duct Control System
AN/ASQ-56-CNI Communications, Navigation and Identification System Autopilot Supporting Systems Air Data Computer Augmented Flight Control System AN/APN-120 (XN-2) Radar Altimeter	

RECONNAISSANCE EQUIPMENT *

Camera - Forward Oblique - 6 inch focal length
 Camera - Vertical - 1.75 inch focal length and 6 inch focal length
 Camera - Panoramic - 18 inch focal length
 Camera - Panoramic - 3 inch focal length
 Camera - Right hand oblique and left hand oblique
 Side Looking Radar
 Passive ECM
 Electronic Flasher Pods (B.P. 110) **

* For Alternate Loadings See Reconnaissance Installation Chart
 ** Only 2 External Tanks can be carried

WEIGHTS

LOADINGS	LBS	L.F.
EMPTY	37,498	
BASIC	38,219	
DESIGN	49,329	4.35 _{nz} **
COMBAT (Alt. No. 1) * 55,617		3.85 _{nz} **
MAX TAKE-OFF (extended long range overload)		
(Field) (ALT. NO. 5)	79,588	2.00 _{nz}
(Cat) (ALT. NO. 5)	79,588	-5.27 _{nx}
MAX LANDING		
(Field) (ALT. NO. 5)	65,988	1.95 _{nz} **
(Arresting)	47,000	4.85 _{nx}

* WITH 3 FUEL CANS IN ARMAMENT TUNNEL
 ** DURING FLIGHT

FUEL AND OIL

GALLONS	NO. TANKS	LOCATION
1430	2	Wing
1285	4	Fuselage
885*	3*	Armament Tunnel JP-5

FUEL GRADE (Applicable) Mil-F-5624C
 FUEL SPEC. NO * 590 GALS (2 fuel cans) with passive ECM equipment or internal store.

OIL

CAPACITY	5.30 (gals)
GRADE	C
SPEC. NO	(Applicable) MIL-L-7808

DIMENSIONS

WING	
Area	753.7 sq ft
Span	53' - 0"
M.A.C.	16' - 9"
Sweepback	37.5°
LENGTH	76' - 6"
HEIGHT	19' - 4"
TREAD	11' - 7.5"

PERFORMANCE SUMMARY

TAKE-OFF LOADING CONDITION	① HI ALT SUPERSONIC MISSION ALTERNATE #1	③ HI ALT SUPERSONIC MISSION ALTERNATE #1 (4) 400 GAL D/T	⑤ HI-LO-HI MISSION ALTERNATE #3 (4) 400 GAL D/T	⑦ HI-LO-HI MISSION ALTERNATE #4 (2) 400 GAL D/T	⑨ HI ALT SUPERSONIC ATTACK 1MK-28 STORE (4) 400 GAL D/T	⑪ HI ALT ATTACK 1 MK-28 STORE (4) 400 GAL D/T
TAKE-OFF WEIGHT lb	65,589	79,189	79,405	72,970	(H) 77,589	(H) 77,589
Fuel Internal/External (JP-5) (USABLE) lb/lb	24480/---	24480/10880	22474/10880	22474/5440	22474/10880	22474/10880
Payload lb	1718	1718	4217	4582	1914	1914
Wing Loading lb/sq ft	87.0	105.1	105.4	96.8	102.9	102.9
Stall Speed - Power Off kn	134	147	147	141	145	145
Take-Off Run at SL - Calm (A) ft	3200	4900	4900	4000	4600	4600
Take-Off at SL 25 Kn Wind (A) ft	2400	3700	3700	3000	3400	3400
Take-Off to Clear 50 Ft - Calm (A) ft	4100	6100	6100	5100	5800	5800
Max Speed/Altitude (B) kn/ft	620/SL	565/SL	565/SL	575/SL	570/SL	570/SL
Rate of Climb at SL (B) fpm	6600	4100	4100	4800	4400	4400
Time: SL to 20,000 Ft (B) min	4.00	7.30	7.40	5.85	6.40	6.40
Time: SL to 30,000 Ft (B) min	7.70	17.35 (E)	17.60 (E)	12.80	14.80	14.80
Service Ceiling (B) ft	37,500	29,900	29,900	33,000	31,800	31,800
COMBAT RANGE naut mi	1950	2665	2414	1900	2634	2634
Average Cruising Speed kn	493	493	493	479	497	497
Cruising Altitude ft	35,800/42,600	28,500/42,600	28,500/41,600	33,200/40,500	30,200/44,800	30,200/44,800
COMBAT RADIUS/MISSION TIME naut mi/hr	475/1.65	820/3.18	1040/4.22	775/3.21	1100/4.28	1320/5.36
Average Cruising Speed kn	493	490	491	478	498	497
Buddy Refuel Radius/Mission Time (D) naut mi/hr	905/3.66 (F)	1315/5.40 (F)	1485/6.13	1260/5.38	1560/6.31(F)	1780/7.47
Buddy Fuel Transferred lbs	8410 (F)	9650 (F)	14,600	13,900	9050(F)	14,000
COMBAT LOADING CONDITION	②	④	⑥	⑧ FLASHER PODS RETAINED	⑩ STORE RETAINED	⑫ STORE RETAINED
COMBAT WEIGHT lb	55,617	62,145	63,163	60,264	61,347	61,347
Engine Thrust	MAXIMUM	MAXIMUM	MAXIMUM	MAXIMUM	MAXIMUM	MAXIMUM
Fuel lb	14,958	21,486	20,282	17,018	20,282	20,282
Combat Speed/Combat Altitude kn/ft	1030/47,300(C)	1030/45,600 (C)	683/SL	660/SL	1060/49,000 (C)	1147/40,400
Rate of Climb/Combat Altitude fpm/ft	500/47,300(C)	500/45,600 (C)	24,800/SL	22,100/SL	500/49,000 (C)	3700/40,400
Combat Ceiling (500 FPM Subsonic) ft	48,400	46,600	46,200	46,600	47,700	47,700
Rate of Climb at SL fpm	27,900	24,900	24,800	22,100	26,700	26,700
Max Speed at SL kn	680	680	680	660	700	700
Max Speed/Altitude kn/ft	1120/40,000	1110/40,000	1110/40,000	1030/35,000	1147/40,000	1147/40,000
LANDING WEIGHT lb	43,749	43,749	45,971	46,336	41,543	41,543
Fuel lb	2640	2640	2640	2640	2640	2640
Stall Speed - Power Off/Appr Power kn/kn	109/103	109/103	112/106	112/106	106/100	106/100
Distance - Ground Roll/Over 50 Ft Obst ft/ft	3500/4800	3500/4800	3650/5050	3700/5100	3300/4600	3300/4600

(A) MAXIMUM AFTERBURNER

(B) MILITARY POWER

(C) COMBAT ALTITUDE PRESENTED FOR THE HIGH ALTITUDE SUPERSONIC MISSIONS IS SUPERSONIC COMBAT CEILING INSTEAD OF ALTITUDE AT THE TARGET

NOTES

(D) A-5C TANKER HAS (4) 400 GAL TANKS PLUS 3 INTERNAL FUEL CANS

(E) TIME TO SERVICE CEILING

(F) RENDEZVOUS REFUEL-INBOUND

(G) SPOTTING: 63 A-5C AIRPLANES ON CVA 59 CLASS CARRIER PER SPOTTING RULES NAEF - ENG-6666, DATED 27 APRIL 1960

(H) FOR ATTACK MISSIONS 9, 11, F, & G RECONNAISSANCE POD IS REMOVED.

EFFECT OF SUPERSONIC DISTANCE ON COMBAT RADIUS

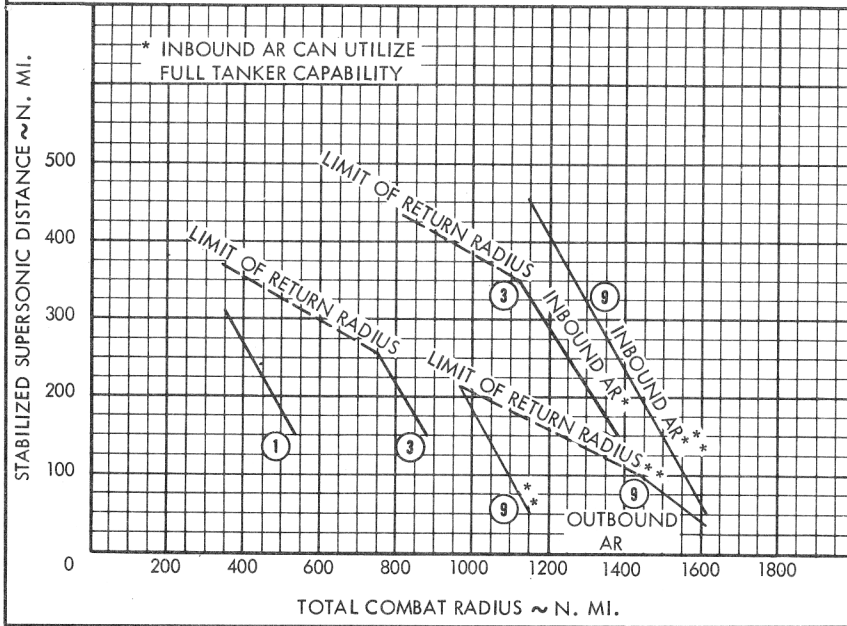

EFFECT OF MACH NUMBER ON COMBAT RADIUS

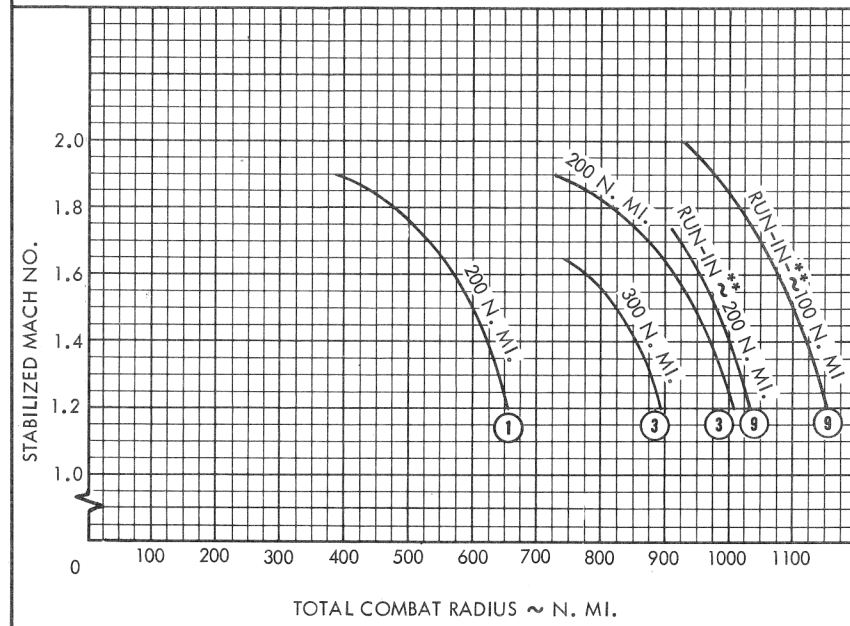

EFFECT OF S. L. DISTANCE ON COMBAT RADIUS

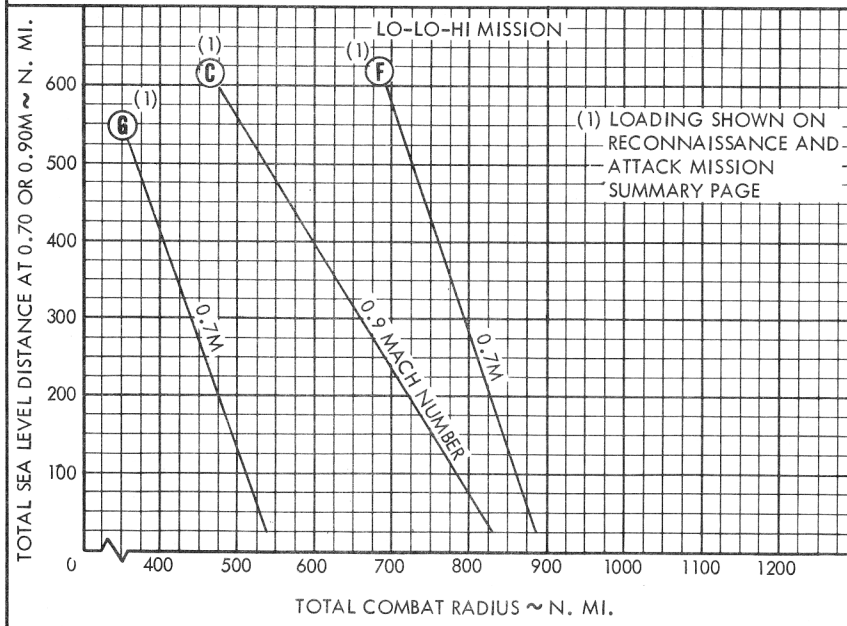

EFFECT OF MACH NUMBER ON COMBAT RADIUS N. MI.

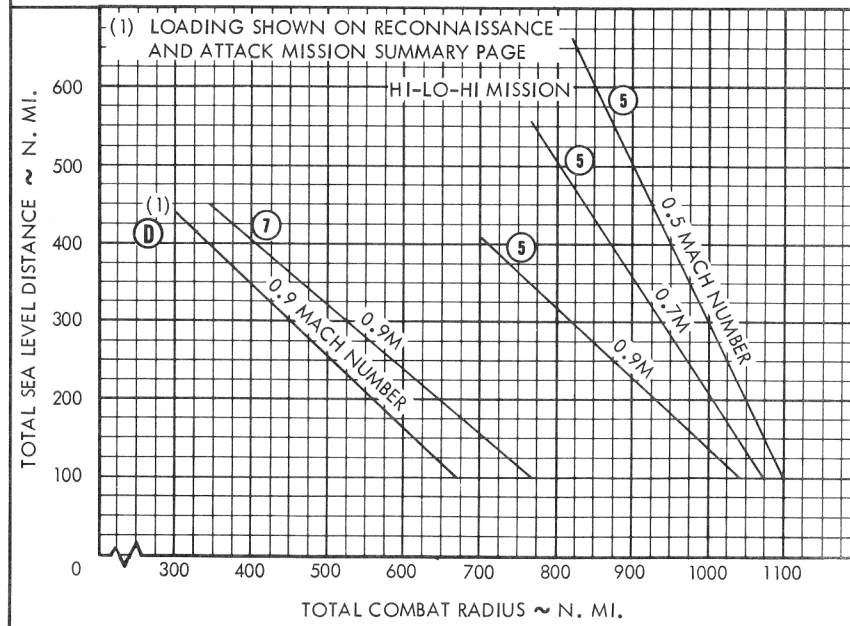

**INCLUDES 10 N. MI. STORE DROP DISTANCE

○ LOADING CONDITION COLUMN NUMBER

NOTES

HIGH ALTITUDE SUPERSONIC MISSION

1. WARM-UP, TAKE-OFF AND ACCELERATE TO CLIMB SPEED.
2. CLIMB: ON COURSE TO OPTIMUM CRUISE ALTITUDE WITH MILITARY RATED THRUST
3. CRUISE OUT: AT ALTITUDES AND SPEEDS FOR MAXIMUM RANGE.
4. ACCELERATE: AT 35,000 FT TO 1.8M WITH MAX A/B
5. CLIMB AND RUN-IN: AT 1.8M WITH MAXIMUM A/B FOR 75 N. MI
6. EXECUTE TURNAROUND: AT 1.33g AND 1.8M (TURN RADIUS 16 N. MI)
7. RUN-OUT: AT 1.8M WITH MAXIMUM A/B FOR 75 N. MI. (TOTAL DISTANCE AT 1.8M INCLUDING TURNAROUND = 200 N. MI).
8. DESCEND AND DECELERATE TO CRUISE ALTITUDE AND SPEED.
9. CRUISE BACK: AT ALTITUDES AND SPEEDS FOR MAXIMUM RANGE
10. RESERVE: 20 MINUTES AT SPEED FOR MAXIMUM ENDURANCE AT S. L. PLUS 5% INITIAL INTERNAL FUEL LOAD (ALL ENGINES OPERATING)

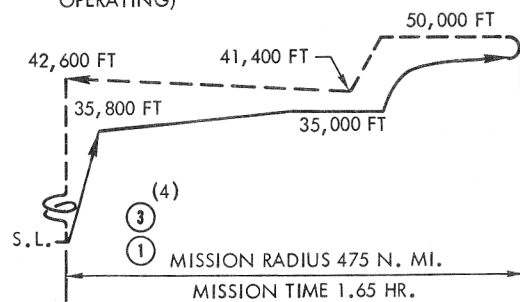

HIGH-LOW-HIGH MISSION

1. WARM-UP, TAKE-OFF AND ACCELERATE TO CLIMB SPEED
2. CLIMB: ON COURSE TO OPTIMUM CRUISE ALTITUDE WITH MILITARY RATED THRUST
3. CRUISE OUT: AT ALTITUDES AND SPEEDS FOR MAXIMUM RANGE
4. DESCEND: TO S. L. (NO FUEL USED, NO DISTANCE GAINED)
5. RUN-IN: 50 N. MI. AT S. L. AT 0.90M
6. RUN-OUT: 50 N. MI. AT S. L. AT 0.90M
7. CLIMB: ON COURSE TO OPTIMUM CRUISE ALTITUDE WITH MILITARY RATED THRUST.
8. CRUISE BACK: AT ALTITUDES AND SPEEDS FOR MAXIMUM RANGE.
9. RESERVE: 20 MINUTES AT SPEED FOR MAXIMUM ENDURANCE AT S. L. PLUS 5% OF INITIAL INTERNAL FUEL LOAD (ALL ENGINES OPERATING)

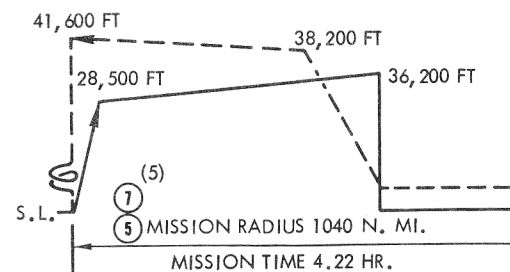

○LOADING CONDITION COLUMN NUMBER

GENERAL NOTES

- (1) Performance is based on Flight Test data (NA63H-2)
- (2) Mission time EXCLUDES TIME FOR WARMUP & TAKE-OFF AND 20 MIN LOITER TIME

- (3) Cycle time is mission time plus 20 MINUTES S.L. LOITER
- (4) Mission radius/mission time Naut. mi./hr. (820/3.18)
- (5) Mission radius/mission time Naut. mi./hr. (775/3.21)

RECONNAISSANCE MISSIONS

MISSION LOADINGS (TAKE-OFF GR. WT. ~ LBS)	HI ALT SUPERSONIC		HI ALT SUBSONIC		HI-LO-HI		LO-LO-HI		LO ALT	
	RADIUS NAUT MI	MISSION TIME-HOURS	RADIUS NAUT MI	MISSION TIME-HOURS	RADIUS NAUT MI	MISSION TIME-HOURS	RADIUS NAUT MI	MISSION TIME-HOURS	RADIUS NAUT MI	MISSION TIME-HOURS
A BASIC RECON-ALTERNATE #1 3600 GALS. INTERNAL (65,589)	475	1.65	955	3.88	795	3.21	570	2.95	450	2.68
B BASIC RECON-ALTERNATE #1 3600 GALS. INTERNAL (4) 400 GALS. D/T (79,189)	820	3.18	1310	5.23	1165	4.75	855	4.23	660	4.02
C ATTACK RECON-ALTERNATE #6 (1) MK-28 INTERNAL (4) 400 GALS. D/T (79,014)	730	2.72	1225	5.00	1055	4.31	785	3.93	605	3.68
D BEACH RECON - ALTERNATE #3 3305 GALS INTERNAL (65805)	—	—	—	—	670	2.72	490	2.43	395	2.35
E NIGHT RECON-ALTERNATE #4 3305 GALS. INT. + (2) 400 GALS. D/T + (2) PODS (72,970)	—	—	—	—	775	3.21	590	2.99	475	2.92
ATTACK MISSIONS										
F (H) (1) MK-28, MK-27, OR MK-43 INT. (4) 400 GAL D/T MK-28 (77,589 LBS.) MK-27 (78,799 LBS.) MK-43 (77,782 LBS.)	1100	4.28	1320	5.36	1115	4.58	825	4.12	655	3.98
G (H) (4) MK-28, MK-43, OR MK-84 3600 GALS. INTERNAL (73,821)	—	—	—	—	585	2.49	475	2.42	408	2.52

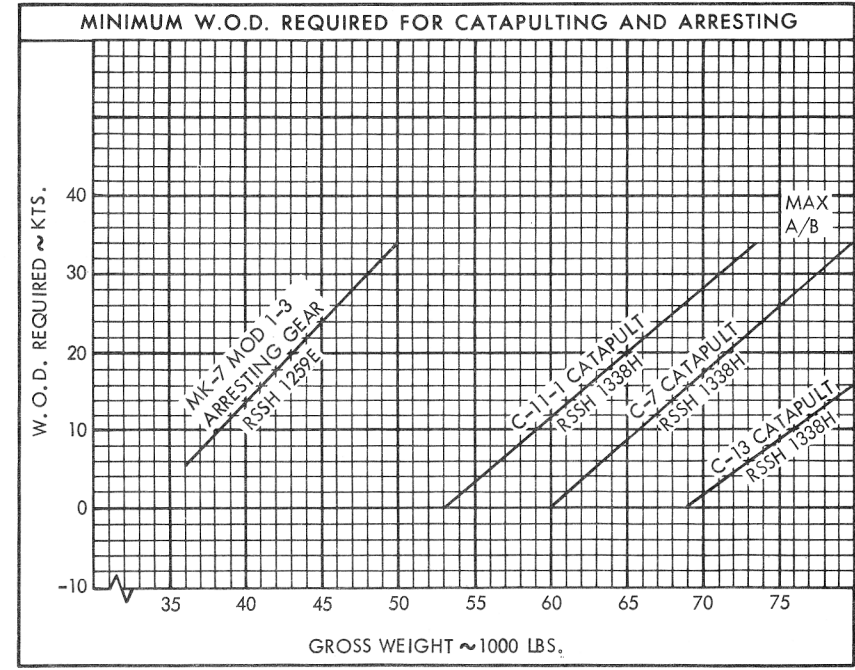
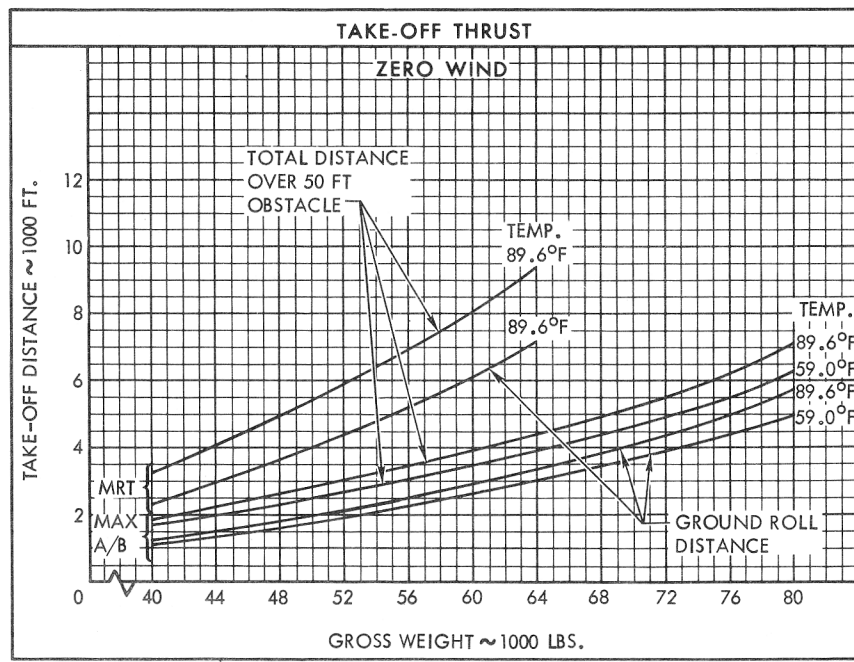
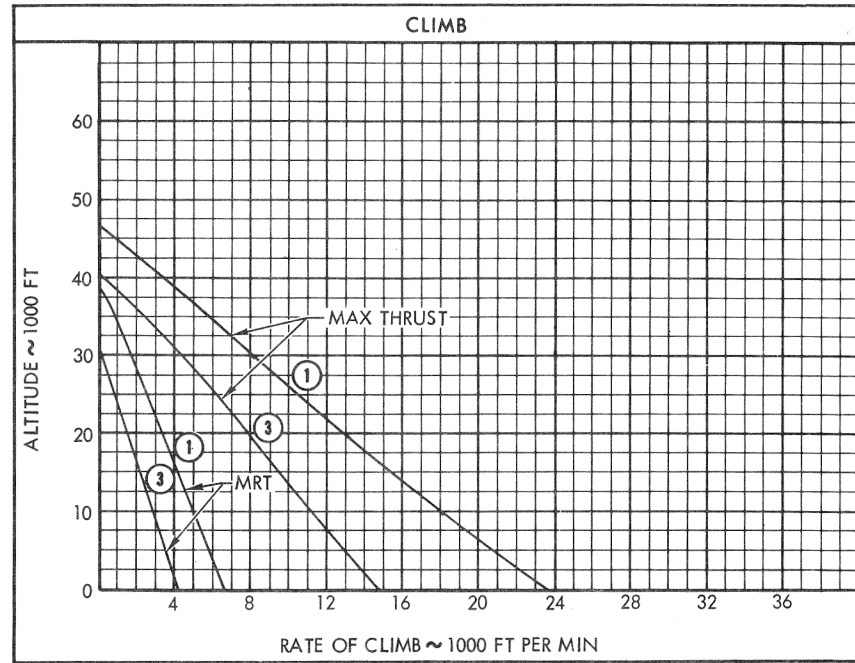
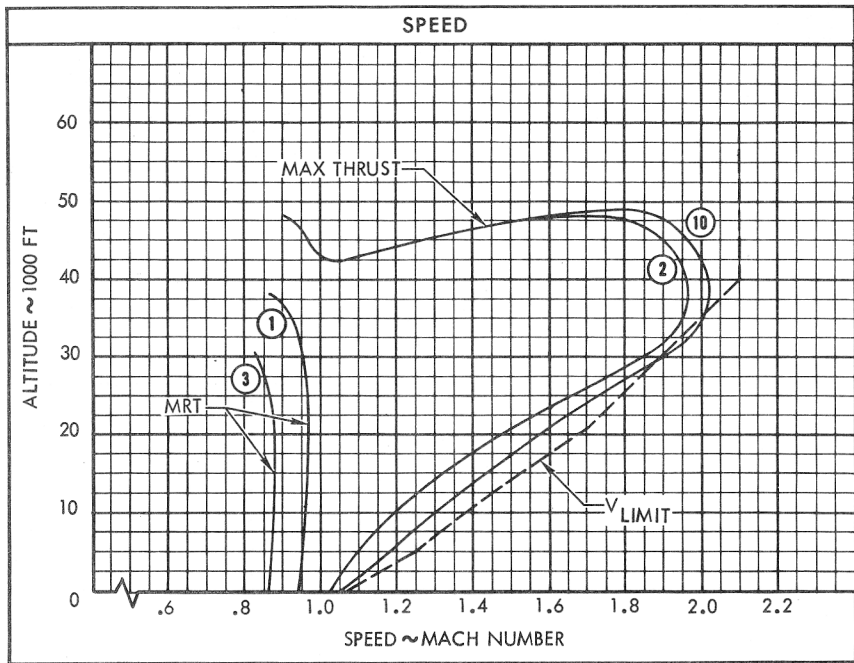

○ LOADING CONDITION COLUMN NUMBER

RECONNAISSANCE MISSIONS

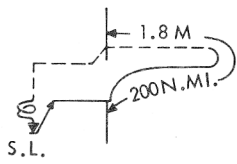
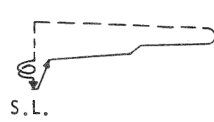
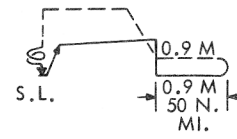
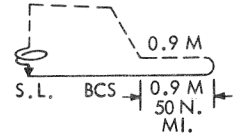
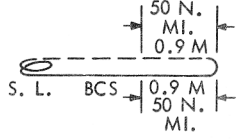
MISSION LOADINGS (TAKE-OFF GR. WT. ~ LBS)	HI ALT SUPERSONIC		HI ALT SUBSONIC		HI-LO-HI		LO-LO-HI		LO ALT	
	RADIUS NAUT MI	MISSION TIME-HOURS	RADIUS NAUT MI	MISSION TIME-HOURS	RADIUS NAUT MI	MISSION TIME-HOURS	RADIUS NAUT MI	MISSION TIME-HOURS	RADIUS NAUT MI	MISSION TIME-HOURS
										
A BASIC RECON-ALTERNATE #1 3600 GALS. INTERNAL (65,589)	475	1.65	955	3.88	795	3.21	570	2.95	450	2.68
B BASIC RECON-ALTERNATE #1 3600 GALS. INTERNAL (4) 400 GALS. D/T (79,189)	820	3.18	1310	5.23	1165	4.75	855	4.23	660	4.02
C ATTACK RECON-ALTERNATE #6 (1) MK-28 INTERNAL (4) 400 GALS. D/T (79,014)	730	2.72	1225	5.00	1055	4.31	785	3.93	605	3.68
D BEACH RECON - ALTERNATE #3 3305 GALS INTERNAL (65805)	—	—	—	—	670	2.72	490	2.43	395	2.35
E NIGHT RECON-ALTERNATE #4 3305 GALS. INT. + (2) 400 GALS. D/T + (2) PODS (72,970)	—	—	—	—	775	3.21	590	2.99	475	2.92

ATTACK MISSIONS

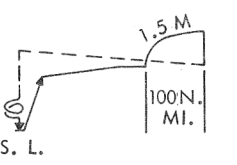
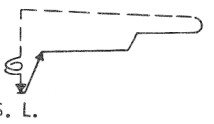
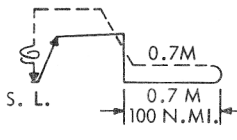
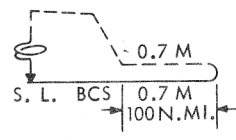
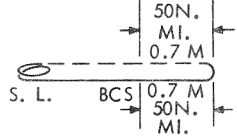
MISSION LOADINGS (TAKE-OFF GR. WT. ~ LBS)	HI ALT SUPERSONIC		HI ALT SUBSONIC		HI-LO-HI		LO-LO-HI		LO ALT	
	RADIUS NAUT MI	MISSION TIME-HOURS	RADIUS NAUT MI	MISSION TIME-HOURS	RADIUS NAUT MI	MISSION TIME-HOURS	RADIUS NAUT MI	MISSION TIME-HOURS	RADIUS NAUT MI	MISSION TIME-HOURS
										
F (H) (1) MK-28, MK-27, OR MK-43 INT. (4) 400 GAL D/T MK-28 (77,589 LBS.) MK-27 (78,799 LBS.) MK-43 (77,782 LBS.)	1100	4.28	1320	5.36	1115	4.58	825	4.12	655	3.98
G (H) (4) MK-28, MK-43, OR MK-84 3600 GALS. INTERNAL (73,821)	—	—	—	—	585	2.49	475	2.42	408	2.52

NOTES

HIGH ALTITUDE SUPERSONIC ATTACK

1. WARM-UP, TAKE-OFF AND ACCELERATE TO CLIMB SPEED.
2. CLIMB: ON COURSE TO OPTIMUM CRUISE ALTITUDE WITH MILITARY RATED THRUST
3. CRUISE-OUT: AT ALTITUDES AND SPEEDS FOR MAXIMUM RANGE
4. CLIMB: AT MAXIMUM RATE OF CLIMB WITH MILITARY THRUST, ON COURSE TO CRUISE CEILING
5. CRUISE-OUT: AT CRUISE CEILING, AT SPEED FOR MAXIMUM RANGE
6. DIVE: AT MAX A/B THRUST (10-DEGREE DIVE) TO 40,000 FT.
7. ACCELERATE: AT MAX A/B THRUST TO 1.5M
8. RUN-IN: AT 100 N. MI. FROM TARGET AND 1.5M INITIATE CLIMBING RUN-IN WITH MAX A/B THRUST
RELEASE INTERNAL STORE: AND RETURN TO ALTITUDE FOR BEST RANGE (NO DISTANCE GAINED OR FUEL ACCOUNTED FOR)
9. CRUISE BACK: AT ALTITUDES AND SPEEDS FOR MAXIMUM RANGE
10. RESERVE: 20 MINUTES AT SPEED FOR MAXIMUM ENDURANCE AT S. L. PLUS 5% OF INITIAL INTERNAL FUEL LOAD (ALL ENGINES OPERATING)

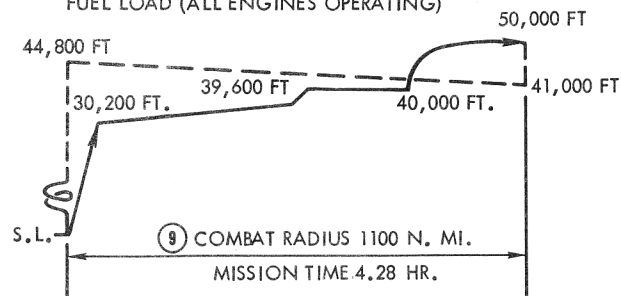

HIGH ALTITUDE ATTACK

1. WARM-UP, TAKE-OFF AND ACCELERATE TO CLIMB SPEED
2. CLIMB: ON COURSE TO OPTIMUM CRUISE ALTITUDE WITH MILITARY RATED THRUST
3. CRUISE-OUT: AT ALTITUDES AND SPEEDS FOR MAXIMUM RANGE
4. CLIMB: AT MAXIMUM RATE OF CLIMB WITH MILITARY THRUST, ON COURSE TO CRUISE CEILING
5. BOMB-RUN: CRUISE IN LEVEL FLIGHT 15 MINUTES AT NORMAL RATED THRUST
6. DROP BOMB:
7. EVASIVE ACTION: 2 MINUTES AT MAXIMUM SPEED WITH NORMAL RATED THRUST AT COMBAT ALTITUDE (NO DISTANCE GAINED)
8. ESCAPE AND RUN-OUT: 8 MINUTES AT MAXIMUM SPEED WITH NORMAL RATED THRUST (RETURN TO ALTITUDE FOR BEST RANGE IS ACCOMPLISHED DURING EVASIVE ACTION AND ESCAPE)
9. CRUISE BACK: AT ALTITUDES AND SPEEDS FOR MAXIMUM RANGE
10. RESERVE: 20 MINUTES AT SPEED FOR MAXIMUM ENDURANCE AT S. L. PLUS 5% INITIAL INTERNAL FUEL LOAD (ALL ENGINES OPERATING)

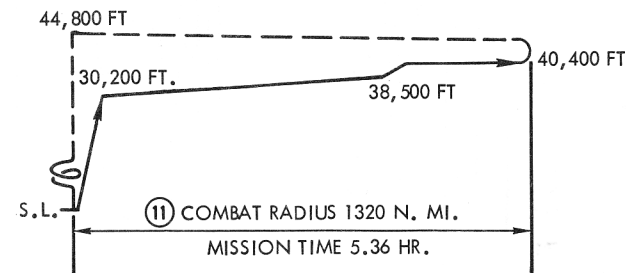

○ LOADING CONDITION COLUMN NUMBER

A-5C EXTERNAL STORES LOADING CHART

CLASSIFICATION (CANCELLED) BY AUTHORITY OF

AIR-9603
ON *6-14-83*

(DATE)
(SIGNATURE)
NAVAL AIR SYSTEMS COMMAND
DEPARTMENT OF THE NAVY

O. A. Person
(RANK)

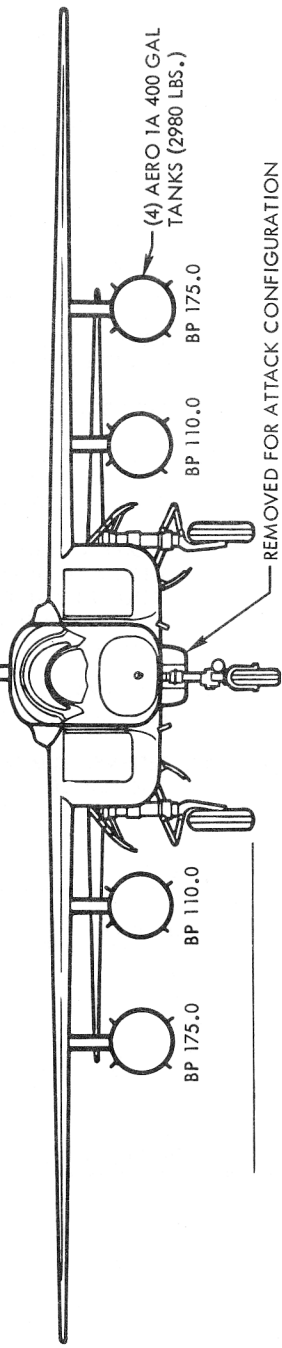

	(2) FLASHER PODS (MOUNTS ON WING) AND (2) AERO 1A 400 GAL TANKS		RECON CONFIG.
	(4) MK 83 G.P. BOMBS (982 LBS)		ATTACK CONFIG.
	(4) MK 84 G.P. BOMBS (2025 LBS.)		
	(4) MK 28 OR MK 43 SPECIAL WEAPON		
	(4) AERO 8A-1 PRACTICE BOMB CONTAINER (354 LBS.)		

NOTE:
(1) ALTERNATE LOADING FOR EXTENDED RANGE REDUCES THE NUMBER OF STORES SHOWN FOR THE ATTACK CONFIGURATION BY ONE HALF AND REPLACES THEM WITH TWO 400 GALLON DROP TANKS AT W.S. 175.