

DECLASSIFIED

Spangenberg

ISSUE OF PAGES

## AIRPLANE CHARACTERISTICS &amp; PERFORMANCE

BUREAU OF AERONAUTICS, NAVY DEPT.

COLUMN NUMBER		1	2		
LOADING CONDITION		Bomber 60% Fuel	Bomber 2 - 300 gal. Tip Tanks		
GROSS WEIGHT	LBS	53860	61800		
EMPTY WEIGHT (ESTIMATED)	LBS	30861			
FUEL/OIL	GALS.	1897/13	3162/22		
FIXED GUNS/AMMUNITION		NONE			
FLEXIBLE GUNS/AMMUNITION		NONE			
ENGINE POWER USED FOR PERFORMANCE		TURBO-PROP MIL. + JET	TURBO-PROP MILITARY		
WING LOADING	LBS/SQ.FT.	64.5	74.0		
POWER LOADING ①	LBS/BHP.				
V-MAX SEA LEVEL	KN	425	369		
V-MAX.	KN/FT.	450/25000	400/25000		
V-STALL GROSS WEIGHT ②	KN	93.4	100.1		
V-STALL WITHOUT FUEL ②	KN	82.9	83.4		
TIME-TO-CLIMB -10000 FT-	MIN	2.0	3.3		
TIME-TO-CLIMB -20000 FT-	MIN	4.6	8.1		
SERVICE CEILING	FT.		39000		
TAKE-OFF DISTANCE -CALM-	FT.		1098		
TAKE-OFF DISTANCE -15 KN-	FT.		797		
TAKE-OFF DISTANCE -25 KN-	FT.		619		
TAKE-OFF DISTANCE -50 FT. OBST.	FT.				
TAKE-OFF TIME	SECONDS				
RATE OF CLIMB -SL-	FT/MIN.	5500	3440		
MAX. RANGE /V-AV. ③	N MI/KN.		2900/320		
RANGE /V-AV -60% NSP-③-	N MI/KN.				
SEARCH RADIUS /V-AV -20% R-	N MI/KN.				
A.S.W. RADIUS /V-AV -20% R-	N MI/KN.				
SCOUT RADIUS	N MI.				
COMBAT RADIUS (SEE NOTE)	N MI.		1215		
ENGINE / PROP GEAR RATIO 2 - Allison *500* Turbo-Prop/15.75:1 - J33-A-8 TURBO JET					
ENGINE RATING BHP/RPM/ALT.	MILITARY		NORMAL		TAKE-OFF
	5100	850 JET/13620/SL	4500 + 800/13620/SL	5100 + 850/13620/SL	
	J-33-A-8				
Military Take-off		4600/ STATIC/11750/SL			
TANKAGE IN GALLONS		OIL	FUEL		
AUX. FIXED	PROTECTED	22	2562		
	UNPROTECTED				
	TOTAL - FIXED INTERNAL	22	2562		
	DROPPABLE -				
	DROPPABLE 2 - 300 GAL. TIP TANKS			600	
TOTAL	22	3162			
NOTE	① BHP AT MAX. CRIT. ALT.				
	② STALL - WITH POWER				
	③ AT 35000' ALTITUDE				

PROPOSAL

DATE 26 FEB. 1948

PAGE 1

MODEL XA2J-1

12157

## AIRPLANE CHARACTERISTICS &amp; PERFORMANCE

BUREAU OF AERONAUTICS, NAVY DEPT.

Cond. (1) represents the airplane when 40% of fuel of cond. (2) has been burned and tip tanks have been dropped.

Bomb capacity varies from 8000# to 12000#. This chart is based on an average bomb load.

RADIUS PROBLEM - COND. (2)

<u>WARM-UP</u>	<u>RENDEZVOUS</u>	<u>CLIMB</u>	<u>CRUISE OUT</u>	<u>COMBAT</u>
30 sec. at Max. Static Thr.	10 min. at SL at V for max. endur. on prop. engs.	to 35000' on prop. at rated power	at 35000' on props. at normal rated power <u>Drop external tanks</u>	50 miles in on all engs. Mil. power Drop bomb 50 miles out All engines Military power
<u>TAKE-OFF</u> 1 min. at T.O. Thrust				
<u>CRUISE BACK</u> at 35000' on props at normal rated power	<u>RESERVE</u> 45 min. at S.L. with props at V for max. End.			

DESCRIPTION:

The XA2J-1 will be a modification of the XAJ-1 in which the R-2800 reciprocating engines will be replaced by Allison XT40 propeller turbine engines. Additional changes made necessary by these new power plants will result in some modifications of the tail, nacelles and fuselage. The fuel load will be greatly increased with a resulting increase in combat radius. Like the XAJ-1, the XA2J-1 can be accommodated only on the CVB's or equivalent carriers. The XA2J-1 cannot be catapulted under average conditions at maximum gross weight.

Wing Area	835.45 sq. ft.
Span	78.38'
Length	68.56'
Height	23.50'

CONTRACTURAL:

- Phase I. Preliminary investigation, engineering development, wind tunnel model testing, and mock-up will be completed during Summer and Fall, 1948.
- Phase II. Complete engineering and construction will be completed about the end of 1949. This phase will be initiated early in Fiscal 1949.

Estimated first flight -- Jan. 1950.

PROPOSAL

26 FEBRUARY 1948

DECLASSIFIED

PAGE 3

MODEL-XA2J-1

AIRPLANE PERFORMANCE

NAVAER-1335 B (REV. 2-47)

BUREAU OF AERONAUTICS, NAVY DEPT.

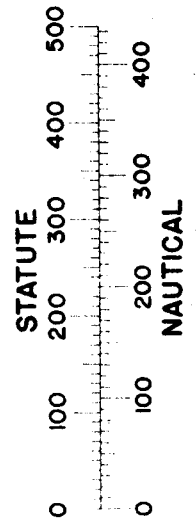
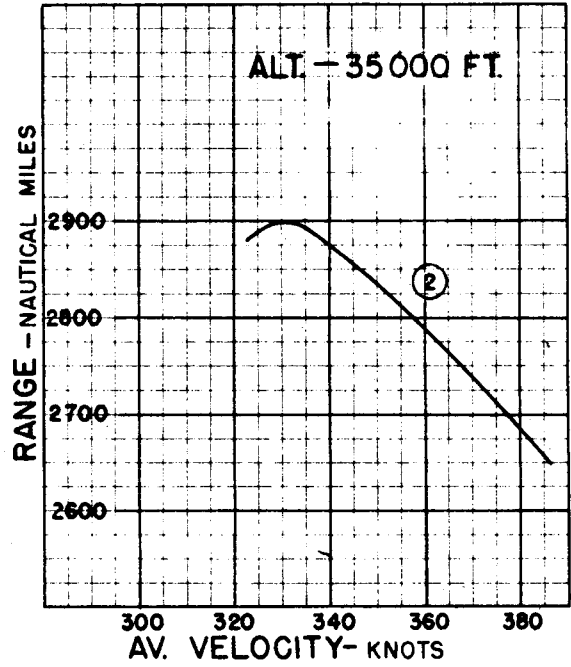
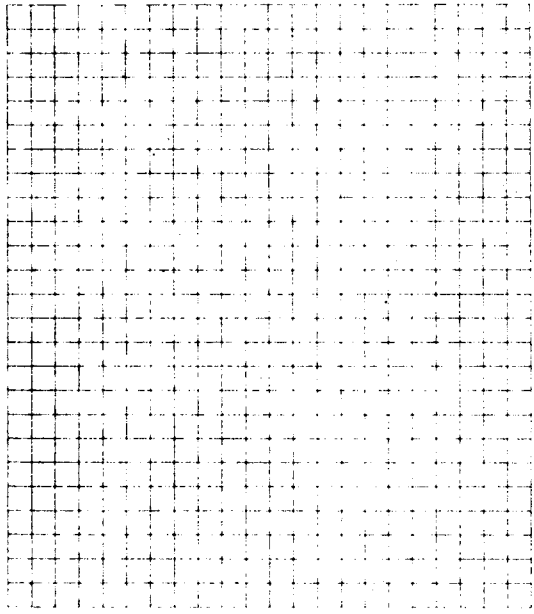
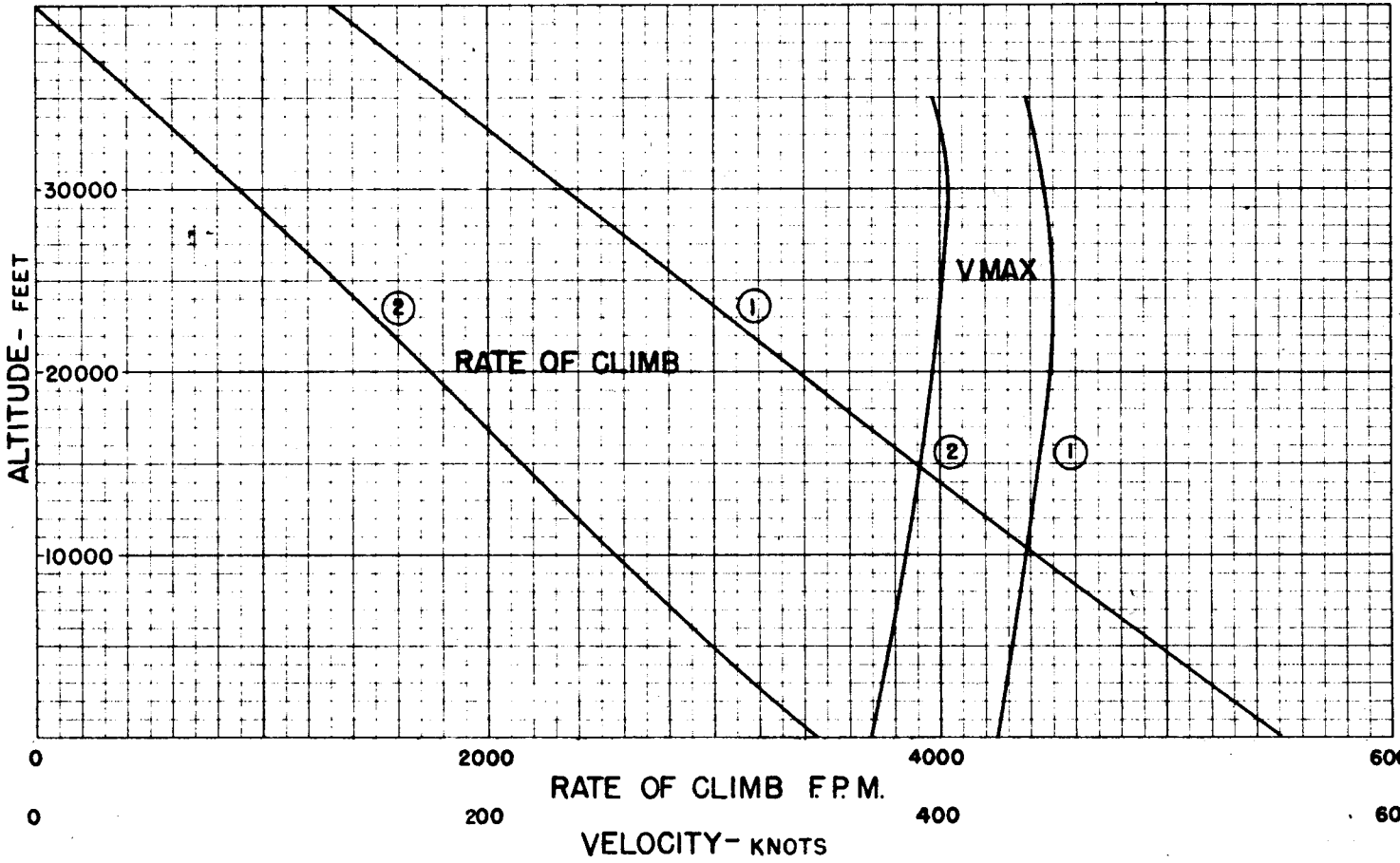

○ LOADING CONDITION COLUMN NUMBER

PROPOSAL

DECLASSIFIED

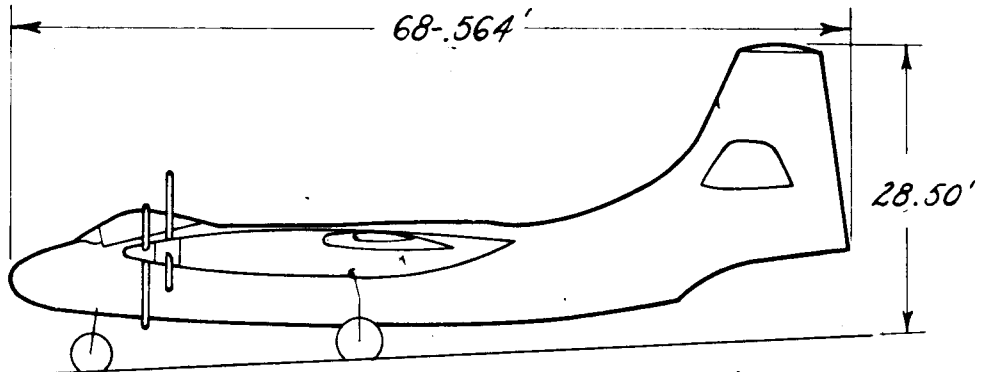
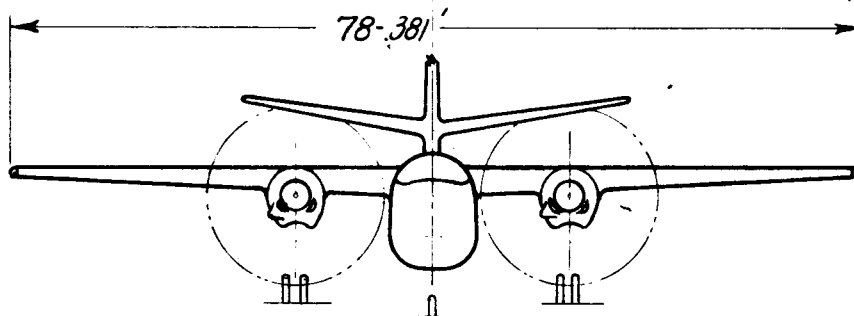
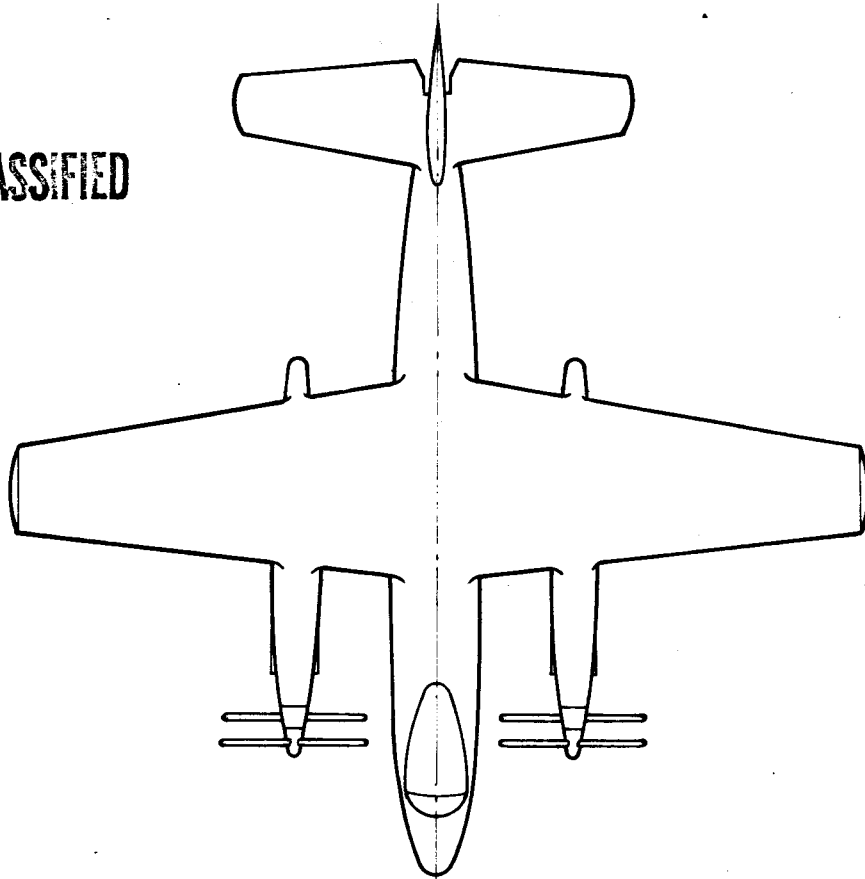

PROPOSAL

26 FEB. 1948

PAGE 4

MODEL XA2J-1