

CHARACTERISTICS SUMMARY

AIRBORNE CIC AIRPLANE

PB-1W

BOEING "FLYING FORTRESS"

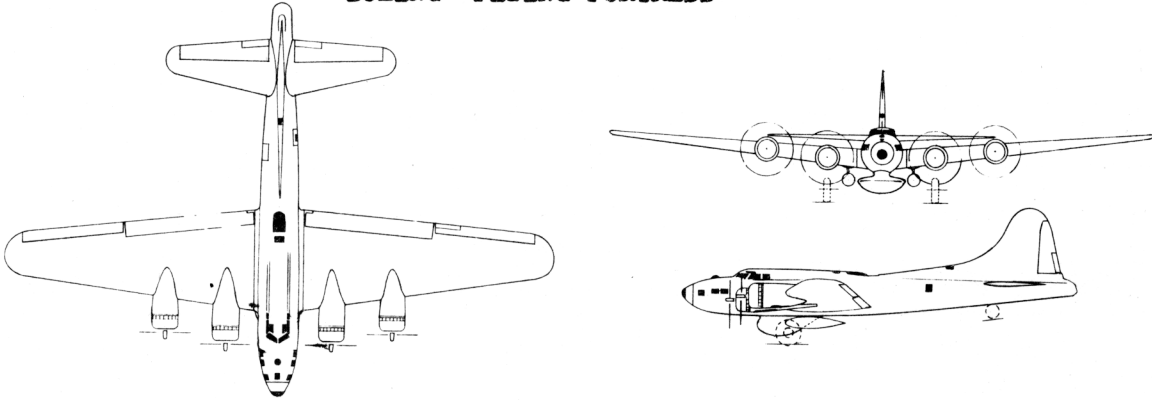

WING AREA 1,420 sq. ft.

LENGTH 74' - 9"

WING SPAN 103' - 9"

HEIGHT 19' - 1"

| AVAILABILITY | | | PROCUREMENT | | | |
|------------------|---------|-------|------------------|--|--|--|
| NUMBER AVAILABLE | | | NUMBER DELIVERED | | | |
| | | | IN FISCAL YEARS | | | |
| ACTIVE | RESERVE | TOTAL | | | | |
| | | | | | | |

11

STATUS

Modification of B-17 airplane.
 AEW-Reconnaissance-CIC Versions.
 First delivery date - December 1945.
 Airplane procured through USAF.

| ENGINES | |
|---------|------------------------|
| 4 | W.A.C. R-1820-97 |
| | T.O. 1200/2500/S.L. |
| | MIL. 1200/2500/32500' |
| | NORM. 1000/2300/35000' |

| FEATURES |
|---|
| Crew - 13 |
| VHF Relay |
| High Powered AEW Search Radar with Radar Relay Provisions |
| High Powered Interrogator |

| ARMAMENT |
|----------------------------------|
| 2 - .50 Cal. Chin Turret |
| 2 - .50 Cal. Upper Turret |
| 2 - .50 Cal. Side Waist |
| 2 - .50 Cal. Tail Flexible Mount |
| (Provisions for above) |

NAVAER 1519 A (REV. 1-49)

UNCLASSIFIED

CHARACTERISTICS SUMMARY

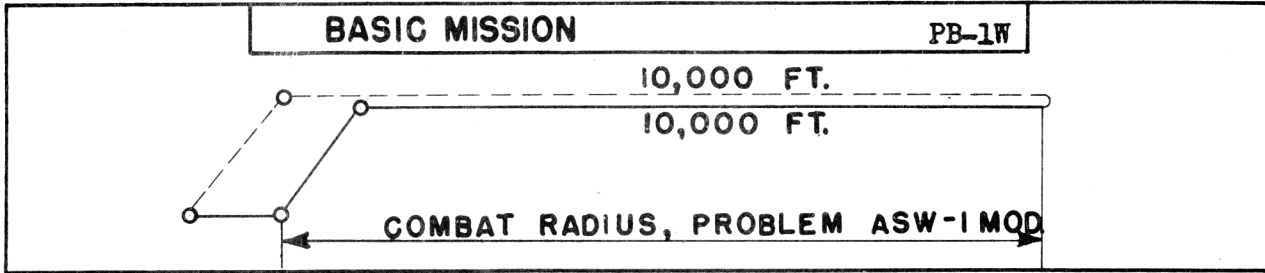

| PERFORMANCE | | |
|---|--|--|
| COMBAT RADIUS | COMBAT RANGE | COMBAT SPEED |
| 1,030 naut. mi. 147 knots avg. 10,000 ft. alt. | 2,580 naut. mi. 147 knots avg. 17.6 hours 10,000 ft. alt. | 222 knots at 10,000 ft., Max. Power MAXIMUM SPEED 257 knots at 32,700 ft., Max. Power |
| CLIMB | CEILING | TAKE OFF |
| 760 ft./min. Sea Level, T. O. wt. Normal Power | 30,200 ft. 100 ft./min., T. O. wt. Normal Power | 3,100 ft. - Calm Ground run - No assist. |
| 1,590 ft./min. Sea Level, Combat Wt. Maximum Power | 32,000 ft. 500 ft./min., Combat Wt. Maximum Power | 4,080 ft. - Calm Over 50' - No assist. |
| LOAD | WEIGHTS | STALLING SPEED |
| Fuel 3,400 gal. fixed 2,780 drop 620 Bombs None Armament None Ammunition None | Empty 38,911 lbs. Combat 55,476 lbs. Take-off 63,636 lbs. | 86.3 knots Flaps down, T. O. wt. TIME TO CLIMB ft. in min. Combat Wt., Max. Power |

12

NAVAER 1519 B (REV. 1-49)

NOTES

Performance is based on flight test of B-17G airplane.
 Range and radius are based on flight test fuel consumption data increased by 5%. Radius equals 40% combat range at 10,000 pounds.
 With all armament in airplane, gross weight is 64,940 pounds, with 2,780 gallons fuel. Range is 1,970 n.mi. at 10,000 feet, and combat speed is 219 knots at 10,000 feet.

UNCLASSIFIED

DECLASSIFIED