

Characteristics Summary

MEDIUM BOMBER..... B-45A

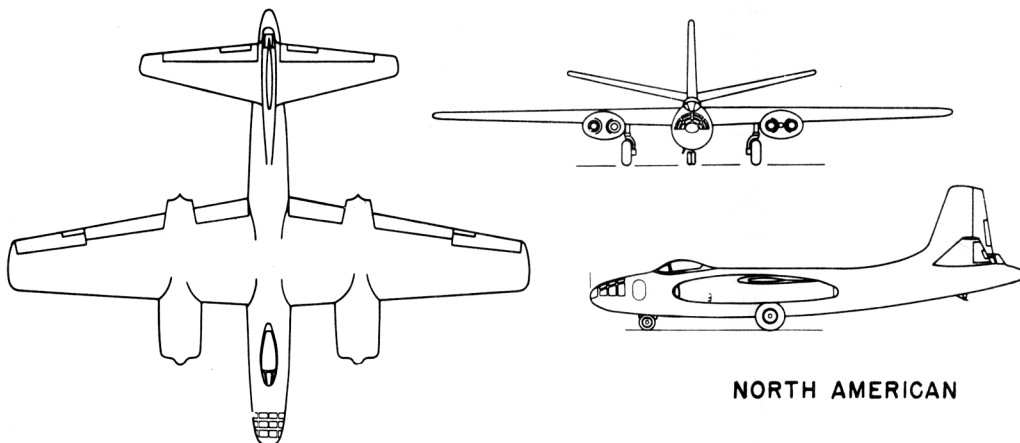

Wing area 1175.2 sq ft Length 75.3 ft
 Span 89.0 ft Height 25.2 ft

AVAILABILITY			PROCUREMENT			
Number available			Number to be delivered in fiscal years			
ACTIVE	RESERVE	TOTAL				

STATUS

PRODUCTION

1. First flight: 17 March 1947 (XB-45)
2. First service use: February 1948
3. In production

POWER PLANT	
(2) J47-GE-1 and (2) J47-GE-3 General Electric	
S.L. Static	LB - RPM
T.O:	5230 - 7950
Max:	5230 - 7950
Nor:	4260 - 7330

FEATURES	
Crew:	4
Cabin Pressurization (6.55 psi max pressure differential)	
Cabin Cooling	
Ejection Seats for Pilot and Co-pilot	
Thermal Anti-icing	
Nav.-Bombing Radar	
Max Fuel Capacity:	5800 gal

ARMAMENT	
Turrets:	1
Guns:	(2) .50 cal
Ammunition:	1200 rds
Max Bomb Load:	22,000 lb
Max Bomb Size:	22,000 lb

Characteristics Summary Basic Mission B-45A

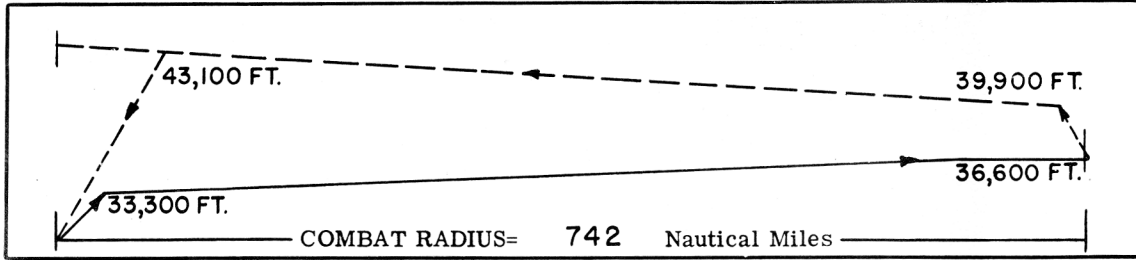

P E R F O R M A N C E

COMBAT RADIUS	COMBAT RANGE	COMBAT SPEED
742 naut. mi with 10,000 lb payload at 397 knots avg. in 3.92 hours.	1439 naut. mi with 10,000 lb payload at 398 knots avg. in 3.7 hours.	442 knots at 35,000 ft alt, max power
		MAXIMUM SPEED
		504 knots at zero ft alt, max power
C L I M B	C E I L I N G	T A K E - O F F
2620 fpm sea level, take-off weight normal power	33,900 ft 100 fpm, take-off weight normal power	ground run 3680 ft no assist — ft assisted
6400 fpm sea level, combat weight maximum power	42,100 ft 500 fpm, combat weight maximum power	over 50 ft height 5240 ft no assist — ft assisted
L O A D	W E I G H T S	S T A L L I N G S P E E D
Bombs: 10,000 lb Ammunition: 1200 rds/.50 cal	Empty..... 45,206 lb Combat... 61,050 lb Take - off 88,400 lb limited by useful load	knots flaps down, take-off weight
Fuel: 4600 gal protected 74 % droppable 26 % external 0 %		TIME TO CLIMB —

N O T E S

- PERFORMANCE BASIS: NACA standard conditions no wind, single airplane;
(a) Fuel consumption based on manufacturer's estimates increased 5%.
- Fuel density 6.7 lb/gal.
- REVISION BASIS: To reflect manufacturer's latest data.

Property of the Air Force Museum
Wright-Patterson Air Force Base
Ohio 45433