

A1
(P) RB-47E / char

~~CONFIDENTIAL~~

SERVICE

Characteristics Summary

RECONNAISSANCE (RANGE EXT.) RB-47E

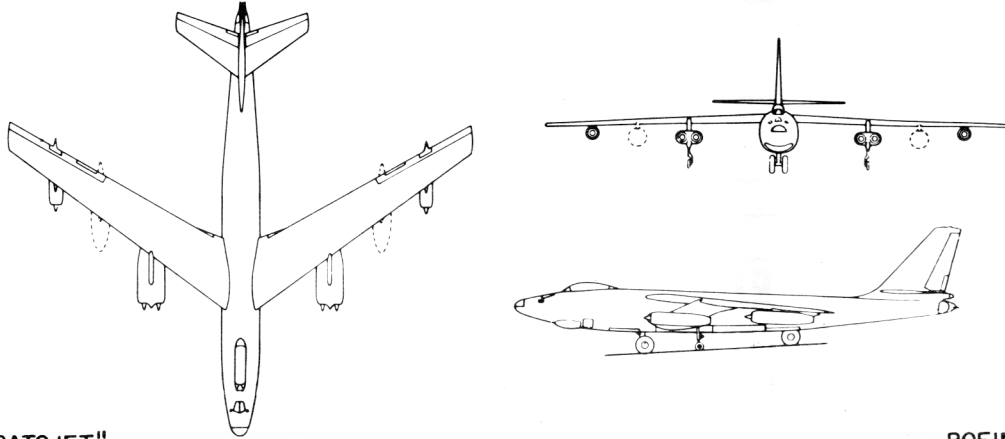

"STRATOJET"

BOEING

Wing Area 1428 sq ft Length 109.8 ft
 Span 116.0 ft Height 28.0 ft

AVAILABILITY

PROCUREMENT

Number available

Number to be delivered in fiscal years

ACTIVE	RESERVE	TOTAL				

STATUS

1. The RB-47E (Range Extension) airplane differs from the Standard RB-47E by the strengthening of the landing gear to permit heavier take-off weights.
2. Estimated completion date of first RB-47E (Range Extension): Jun 54
3. The Range Extension modification is effective on the 21st RB-47E and subsequent.

Navy Equivalent: None

Mfr's Model: 450-158-36

POWER PLANT

(6)J47-GE-25
 General Electric
 ENGINE RATINGS

S.L.S.	LB	- RPM	- MIN
Max(wet):	6970	- 7950	- 5
	5970	- 7950	- 5
Mil:	5670	- 7800	- 30
Nor:	5320	- 7630	- Cont

ATO
 No. & Model .. *(33)14DS1000
 Thrust (lb) 33,000
 Duration (sec) 14

or
 No. & Model ..*(33)15KS1000
 Thrust (lb) 33,000
 Duration (sec) 15

* Manufactured by Allegheny
 **Manufactured by Aerojet

FEATURES

Crew 3
 Thermal Anti-icing
 AN/APQ-31A Bombing-
 Navigation Radar
 A-5 Fire Control System
 Anti-Skid Brakes
 Approach Chute
 Braking Chute
 Ejection Seats
 Internal Fuel Tank Purging
 Single-Point and Air Re-
 fueling
 External Droppable ATO
 Rack

Max Fuel Cap: *18,474 gal

*Includes wing drop tanks &
 large ATO tank

ARMAMENT

Turrets: 1
 Guns: 2x20mm(M24A1)
 Ammunition (tot):. . 700 rds

PHOTO. EQUIP.

Vertical Camera Station
 (1) K-38;*(1) K-37;*(1) T-11
 Tri-Camera Station
 (3) KA-3
 Forward Oblique Station
 (1) K-38
 Split Vertical Station
 (2) K-38; *(K-37)
 Flash Bombs: . . 10/M-120
 plus
 Photoflash Cart. 200/M-112

*Alternate Installations

Classification cancelled
or changed to **Unclassified**

AUTH: AFSC AF 4c
 By: A.R. Sonnborn
 Date: 19 Jun 64
 Dir 5200.10
 13 Dec 1966

Deleted: HTH Ed,
 Add Mr. J. J. 25 Jul 57

Signature and Grade

18 DEC 53

~~CONFIDENTIAL~~

RB-47E
(RANGE EXTENSION)

3rd Ed addn #9

53 WC 12000

Characteristics Summary Basic Mission RB-47E
(RANGE EXTENSION)

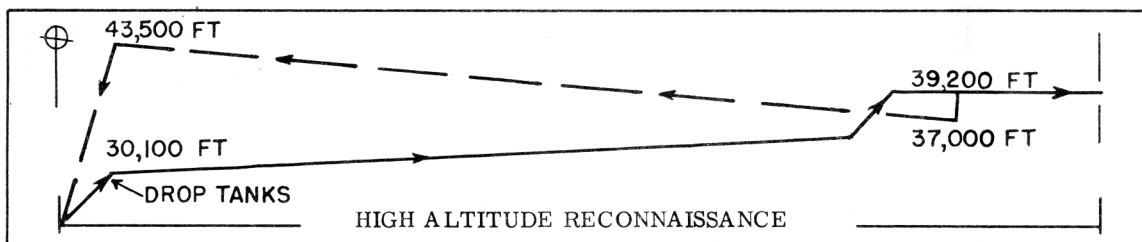

PERFORMANCE

COMBAT RADIUS	FERRY RANGE	S P E E D
1915 naut. mi with 720 lb chaff at 433 knots avg. in 8.92 hours.	3935 naut. mi with 15,969 gal fuel at 433 knots avg. in 9.15 hours at 200,000 lb T.O. wt.	COMBAT 469 ^(c) knots at 39,200 ft alt, max power MAX 497 ^(c) knots at 20,000 ft alt, max power BASIC 469 ^(c) knots at 35,000 ft alt, max power
C L I M B	C E I L I N G	T A K E - O F F
2110 ^(d) fpm sea level, take-off weight normal power	31,500 ^(d) ft 100 fpm, take-off weight normal power	ground run 8050 ft 5650 ft no assist assisted
4470 fpm sea level, combat weight maximum power	39,800 ft 500 fpm, combat weight maximum power	over 50 ft height 9450 ft 7100 ft no assist assisted
L O A D	W E I G H T S	S T A L L I N G S P E E D
Chaff: 720 lb Ammunition: 700 rds/20mm Fuel: 15,858 gal protected 63 % droppable 8 % external 8 %	Empty..... 81,100 lb Combat... 130,180 lb Take - off 200,000 lb (2) limited by structure	140 knots power-off, landing config- uration, take-off weight TIME TO CLIMB _____

N O T E S

- Performance Basis:
 - Flight test data
 - All approved weight reduction items incorporated
 - Structural limit
 - Values quoted are for T.O. weight less ATO, water and alcohol
- Includes 4610 lb ATO and 5300 lb water and alcohol
- Revision Basis: Initial Issue

Property of the Air Force Museum
Wright-Patterson Air Force Base
Ohio 45433