

Characteristics Summary

BOMBER TB-47B

Duplicate in folder

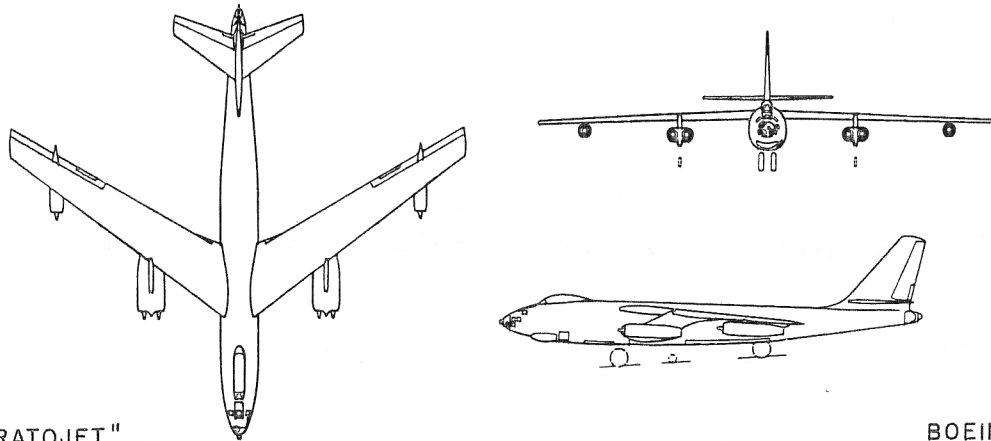

"STRATOJET"

BOEING

Wing Area 1428 sq ft Length 107.1 ft
 Span 116.0 ft Height 27.9 ft

AVAILABILITY			PROCUREMENT			
Number available			Number to be delivered in fiscal years			
ACTIVE	RESERVE	TOTAL				

STATUS

1. The TB-47B is a modified B-47B accomplished by the Training Command and is effective on aircraft serial Nr 49-2642 thru 51-2091.
2. Modifications completed: Oct 55

Navy Equivalent: None

Mfr's Model: 450-11-10

POWER PLANT	FEATURES	ARMAMENT
(6) J47-GE-23 General Electric ENGINE RATINGS S.L.S. LB - RPM - MIN Max: 5910 - 7950 - 5 Mil: 5620 - 7800 - 30 Nor: 5270 - 7630 - Cont ATO Nr & Model.*†(33)14AS1000 Thrust (lb) 33,000 Duration (sec) 14 or Nr & Model...†(19)15KS1000 Thrust (lb) 19,000 Duration (sec) 15 † Manufactured by Aerojet *See note (b), Notes block	Crew 4 Thermal anti-icing K-4A bomb. navig. radar Anti-skid brakes Braking parachute Bail-out spoiler door Vertical camera Max fuel cap: 13,390 gal	Tail turret, guns and associated equipment removed. Same bombing capabilities as B-47B.

Characteristics Summary Basic Mission TB-47B

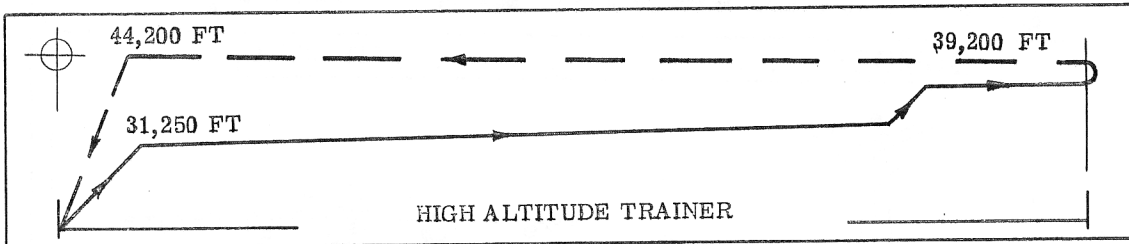

PERFORMANCE		
COMBAT RADIUS	FERRY RANGE	S P E E D
1666 naut. mi with 10,000 lb payload at 433 knots avg. in 7.73 hours.	3548 naut. mi with 13,390 gal fuel at 432 knots avg. in 8.24 hours at 168,832 lb T.O. wt.	COMBAT 484 knots at 39,200 ft alt, max power MAX 528 knots at (c) 16,300 ft alt, max power BASIC 491 knots at 35,000 ft alt, max power
C L I M B	C E I L I N G	T A K E - O F F
2650 fpm sea level, take-off weight normal power	34,250 ft 100 fpm, take-off weight normal power	ground run 8600 ft — ft no assist assisted
4875 fpm sea level, combat weight maximum power	41,200 ft 500 fpm, combat weight maximum power	over 50 ft height 9950 ft — ft no assist assisted
L O A D	W E I G H T S	S T A L L I N G S P E E D
Bombs: 10,000 lb Fuel: 13,390 gal protected 100 % droppable 0 % external 0 %	Empty..... 76,617 lb Combat... 120,100 lb Take - off 179,292 lb limited by space	152 knots power-off, landing config- uration, take-off weight
		T I M E T O C L I M B

N O T E S

1. Performance Basis:
 (a) Flight test data
 (b) Displacement rack must be used in carrying (19)15KS1000 ATO bottles and (30)16NS1000 (Philips Petroleum) ATO bottles.
 (c) Placard speed

2. Revision Basis: To reflect change in engine model, fuel capacity and performance figures.