

Deleted  
Between #123, Add Nr 24; 24 Apr 57  
and 5th Ed; Add Nr 1; 16 Sep 57

~~Confidential~~ *Unclassified*  
~~SECRET~~

A-1  
(X) B-47D/CAAN

EXPERIMENTAL

Classification cancelled  
or changed to ~~Confidential~~ *Unclassified*  
AUI AFSC AF 46 class *Guided Bomb*  
By *a. R. Sonneborn* 1 Apr 64 *200 BIR 5200.10*  
Signature and Grade *23 Oct 1967 - 8 Jan 68*



# Standard Aircraft Characteristics

BY AUTHORITY OF  
THE SECRETARY  
OF THE AIR FORCE

## XB-47D

Boeing

TWO YT49-W-1  
WRIGHT  
AND  
TWO J47-GE-23  
GENERAL ELECTRIC

1 JUL 55

~~SECRET~~

XB-47D

4th Ed addn # 7

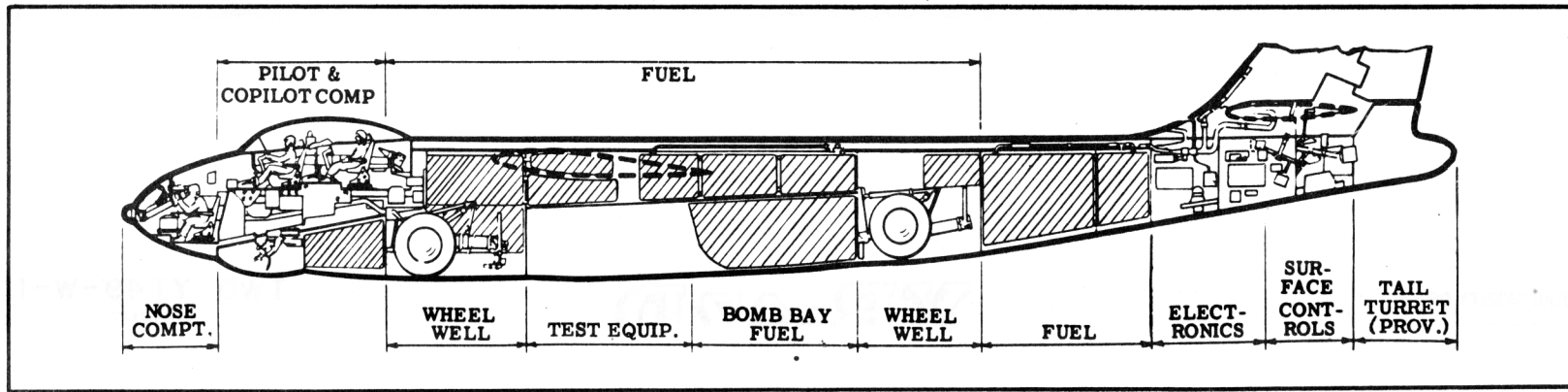
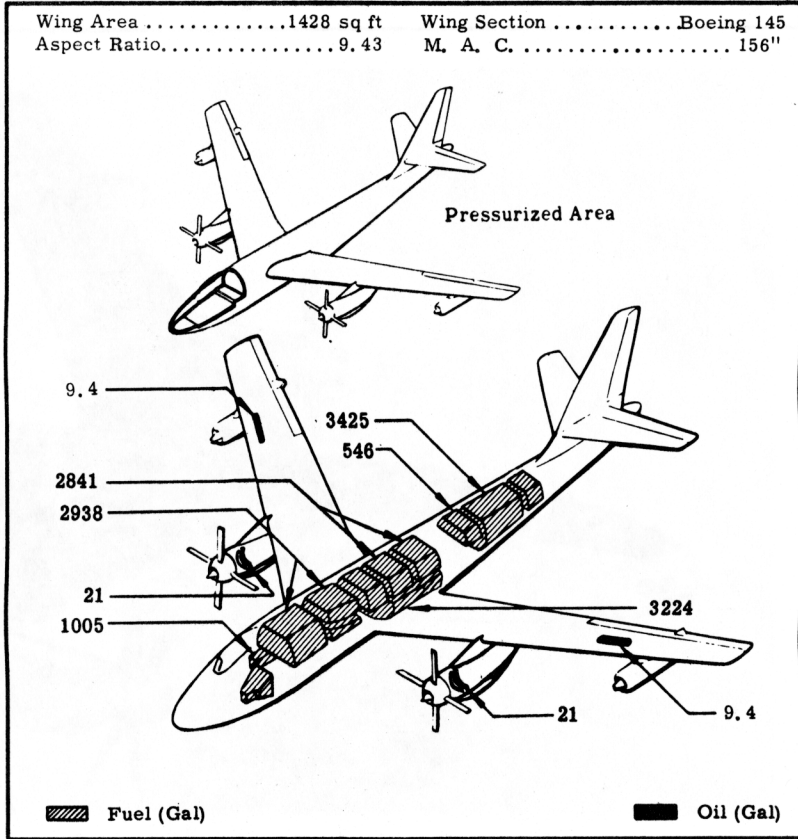
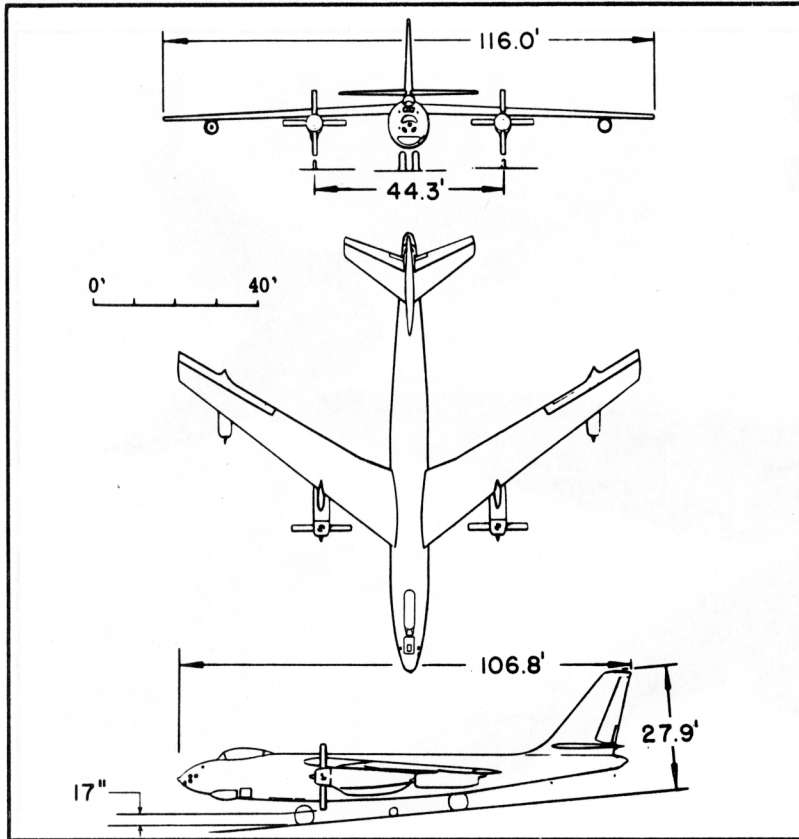

XB-47D

### POWER PLANT

No & Model,..... (2) YT49-W-1  
 Mfr .....Wright  
 Engine Spec No. ....875-E  
 Type .....Axial  
 Red. Gear Ratio.....0.143  
 Prop Mfr.....Curtiss  
 Blade Design No. ....C-846SA  
 Prop Type.....Reversible  
 No. Blades .....4  
 Prop Diameter .....15'0"  
 Plus  
 No. & Model .....(2) J47-GE-23  
 Mfr .....General Electric  
 Type .....Axial  
 Length.....145"  
 Diameter .....39.5"  
 Weight (dry) .....2512 lb

### ENGINE RATINGS

(2) YT49-W-1  
 S. L. S. ESHP - SHP - LB - RPM - MIN  
 T. O. 9710 - 8500 - 3025 - 8000 - 5  
 Mil: 9710 - 8500 - 3025 - 8000 - 30  
 Nor: 8770 - 7700 - 2600 - 7700 - Cont  
 Plus  
 (2) J47-GE-23  
 S. L. Static LB - RPM - MIN  
 Max: \*5910 - 7950 - 5  
 Mil: \*5620 - 7800 - 30  
 Nor: \*5270 - 7630 - Cont  
 \* No inlet screens

### DIMENSIONS

Wing  
 Span .....116.0'  
 Incidence (root) .....2°40'  
 (tip) .....2°45'  
 Dihedral .....0°  
 Sweepback (LE) .....36°38'  
 Length .....106.8'  
 Height .....27.9'  
 Tread (outrigger) .....44.3'  
 Prop Grd Clearance .....17.0"

## Mission and Description

Navy Equivalent: None Mfr's Model: 450-162-28

The XB-47D is a high speed, long range composite turbo-prop, turbo-jet bomber whose mission is to serve as a test bed for determining feasibility of turbo-prop utilization.

The normal crew consists of pilot, co-pilot-gunner, and bombardier-navigator.

Features incorporated, for improved crew comfort and efficiency are automatic heating, ventilation, and pressurization; hydraulic boost on all control surfaces.

Reversible propellers as well as an emergency braking parachute are used to decrease landing roll distance.

Single-point ground refueling is provided.

## Development

Design Initiated ..... Feb 51  
 Contract Approval ..... Apr 51  
 Mock-up ..... Jan 52  
 First Flight ..... Jul 55 (est)  
 First Acceptance ..... Feb 56 (est)  
 Phase II contract for one prototype only  
 XB-47D developed from B-47B

### WEIGHTS

Loading	Lb	L. F.
Empty	79,800(E)	
Basic	82,409(E)	
Design	125,000	3.0
Combat	*121,850	
Max T. O.	†184,428	2.0
Max Land	‡180,000	

(E) Estimated  
 \* For Basic Mission  
 † Limited by space  
 ‡ Limited by structure  
 See note (b) page 6

### FUEL

Location	No. Tanks	Gal
Fwd, Main*	1	2938
Fwd, Main Aux*	1	1005
Ctr, Main*	1	2841
Aft, Main*	1	3425
Aft, Aux*	1	546
Bomb Bay*	1	3224
See note (d) page 6	Total	13,979
Grade		JP-4
Specification		MIL-F-5624A

### OIL

(YT49-W-1)  
 Nacelle ..... 2 ..... 42  
 Grade ..... Synthetic; WS-2463  
 Specification ..... MIL-L-7808A  
 (J47-GE-23)  
 Wing ..... 2 ..... 18.8  
 Grade ..... 1005  
 Specification ..... MIL-L-6081A  
 \*Self-Sealing

### ELECTRONICS

UHF Command ..... AN/ARC-27  
 Omni-Dir. Rec'vr ..... AN/ARN-14  
 Radio Compass ..... AN/ARN-6  
 Interphone ..... USAF Combat  
 Marker Beacon ..... AN/ARN-12  
 Identification ..... AN/APX-6  
 Liaison ..... AN/ARC-21  
 ECM ..... AN/APT-5A  
 Radar Beacon ..... AN/APN-76  
 Emergency Keyer ..... AN/ARA-26  
 Glide Path ..... AN/ARN-18

### BOMBS

See note (c) page 6

### GUNS

See note (c) page 6

# Loading and Performance - Typical Mission

C O N D I T I O N S	BASIC MISSION	FERRY RANGE
	I	II
TAKE-OFF WEIGHT (lb)	184,428	174,428
Fuel at 6.5 lb/gal (grade JP-4) (lb)	90,865	90,865
Payload (bombs) (lb)	10,000	NONE
Wing loading (lb/sq ft)	129.2	122.1
Stall speed (power off) (kn)	154	150
Take-off ground run at SL ① (ft)	4850	4230
Take-off to clear 50 ft ① (ft)	7320	6500
Rate of climb at SL ③ (fpm)	2910	3200
Rate of climb at SL (one engine out) ⑤ ② (fpm)	1490	1640
Time: SL to 20,000 ft ③ (min)	9.8	8.9
Time: SL to 30,000 ft ③ (min)	19.7	17.7
Service ceiling (100 fpm) ③ (ft)	33,750	35,000
Service ceiling (one engine out) ② (ft)	19,750	21,800
COMBAT RANGE ④ (n. mi.)	—	5759
COMBAT RADIUS ④ (n. mi.)	2717	—
Average cruise speed (kn)	402	402
Initial cruising altitude (ft)	24,250	26,100
Target speed ③ (kn)	437	—
Target altitude (ft)	40,000	—
Final cruising altitude (ft)	42,400	42,400
Total mission time (hr)	13.7	14.5
COMBAT WEIGHT (lb)	121,850	90,670
Combat altitude (ft)	40,000	42,400
Combat speed ② (kn)	461	476
Combat climb ② (fpm)	720	1400
Combat ceiling (500 fpm) ② (ft)	41,500	47,300
Service ceiling (100 fpm) ③ (ft)	42,500	48,100
Service ceiling (one engine out) ⑤ ③ (ft)	34,800	41,600
Max rate of climb at SL ② (fpm)	5140	7460
Max speed at 13,500 ft ② (kn)	519	519
Basic speed at 35,000 ft ② (kn/ft)	479	487
LANDING WEIGHT (lb)	90,670	90,670
Ground roll at SL ⑥ (ft)	2750	2750
Ground roll (auxiliary brake) ⑦ (ft)	1330	1330
Total from 50 ft ⑥ (ft)	3750	3750
Total from 50 ft (auxiliary brake) ⑦ (ft)	2330	2330

- N O T E S**
- ① T. O. Power
  - ② MAX Power
  - ③ Normal Power
  - ④ Detailed descriptions of RADIUS and RANGE missions given on page 6.

- ⑤ One YT-49 feathered
- ⑥ Turbo-props at full reverse
- ⑦ With drag chute and reverse thrust

**PERFORMANCE BASIS:**

- (a) Data source: Estimated data plus B-47B Flight Test.
- (b) Performance is based on powers shown on page 3.



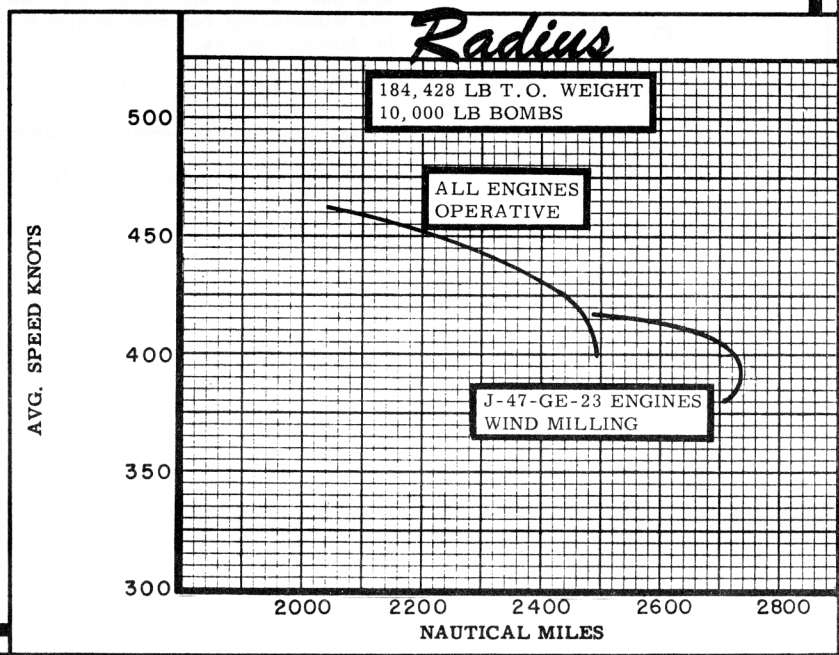
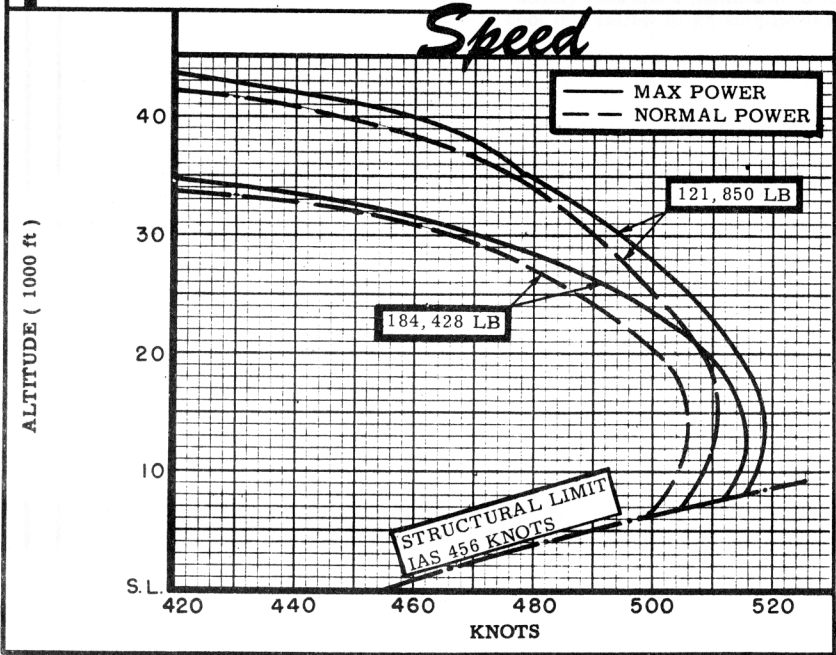
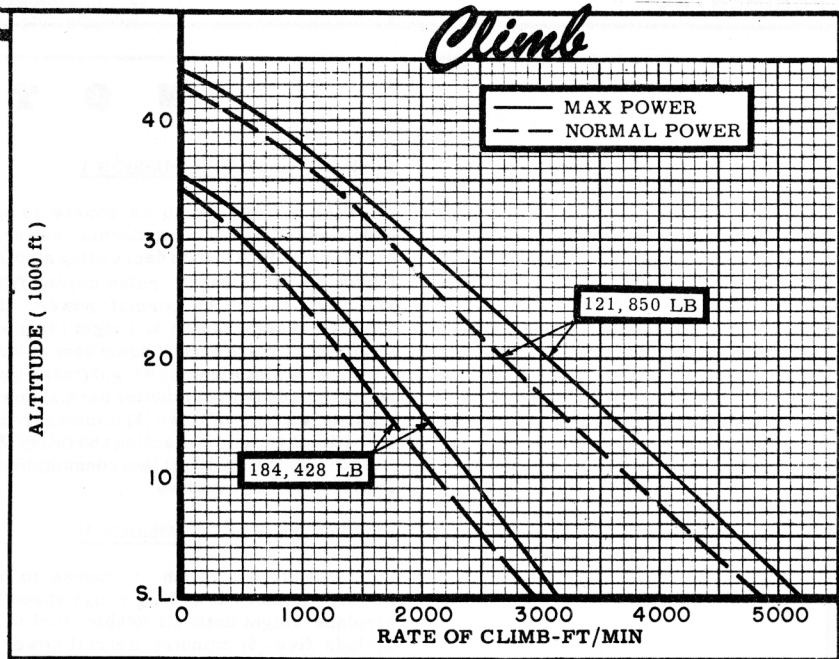
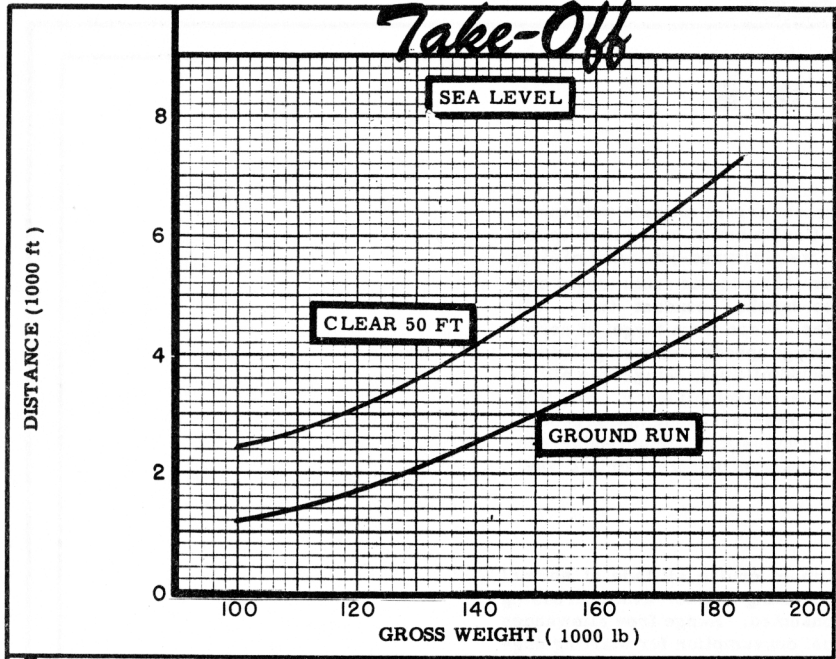

**N O T E S**FORMULA: RADIUS MISSION I

Take-off and climb on course to optimum cruise altitude with turbo-props and turbo-jets at normal power. Cruise out at long range speeds increasing altitude with decreasing airplane weight (turbo-jets windmilling). Climb so as to reach cruise ceiling fifteen (15) minutes from target and run into target at normal power, drop bombs, conduct two (2) minutes evasive action and eight (8) minutes escape from target at normal power. Cruise back to home base at long range speeds increasing altitude with decreasing airplane weight (turbo-jets windmilling). Range free allowances include five (5) minutes normal power fuel consumption for starting engines and take-off, two (2) minutes normal power fuel consumption at combat altitude for evasive action and thirty (30) minutes of maximum endurance (turbo-jets windmilling) fuel consumption at sea level plus 5% of initial fuel load for landing reserve.

FORMULA: RANGE MISSION II

Take-off and climb on course to optimum cruise altitude at normal power. Cruise out at long range speed increasing altitude with decreasing airplane weight until all usable fuel is consumed. Range free allowances include five (5) minutes normal power fuel consumption for starting engines and take-off and thirty (30) minutes of maximum endurance (turbo-jets windmilling) fuel consumption at sea level plus 5% of initial fuel load for landing reserve.

GENERAL NOTES

- (a) All cruise is performed with turbo-jets windmilling.
- (b) Take-off weight as per Detail Specification D-12250 dated 1 February 1952 but as yet not substantiated by WADC.
- (c) The XB-47D is to be delivered as a test bed with no tactical equipment. However, for comparative purposes, performance shown herein is based on the airplane with the tactical equipment installed.
- (d) Provisions are incorporated to permit installation of 2 wing drop tanks (3390 gal tot).

Property of the Air Force Museum  
Wright-Patterson Air Force Base  
Ohio 45433