

A-1
B-52 D / char

~~SECRET~~

SERVICE

DE/ETZ d
4th Ed, Add Nr 14
1 May 56

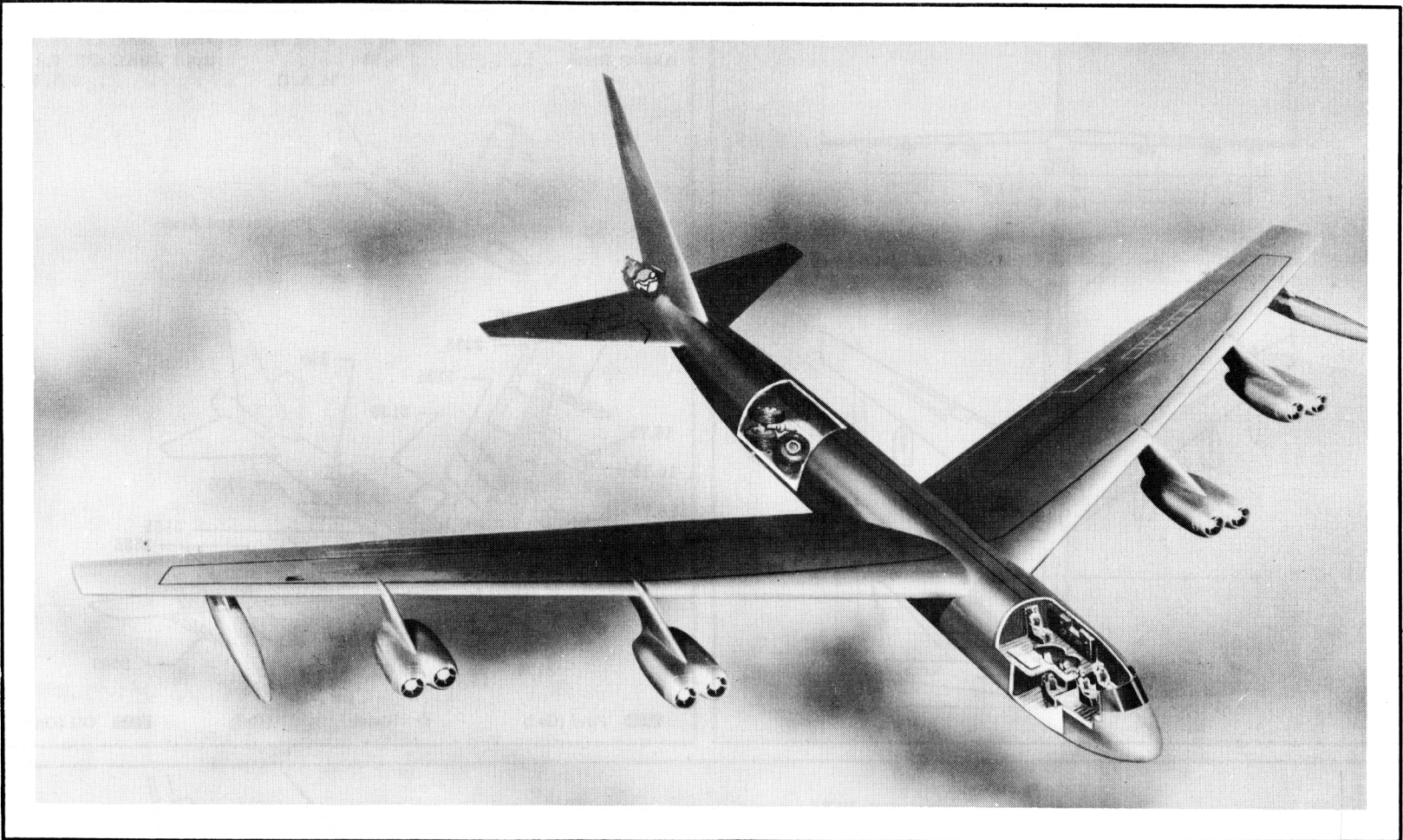

CLASSIFICATION CANCELLED
(OR CHANGED TO *Unclassified*)
BY AUTHORITY OF *DoD DIR 500.10*
(INDIVIDUAL OR WRITTEN AUTHORITY)
A. R. Somelorn 29 Mar 67

Standard Aircraft Characteristics

BY AUTHORITY OF
THE SECRETARY
OF THE AIR FORCE

B-52D
STRATOFORTRESS
Boeing

EIGHT J57-P-19W
PRATT & WHITNEY

5 OCT 54

~~SECRET~~

B-52D

4th Ed addn #1

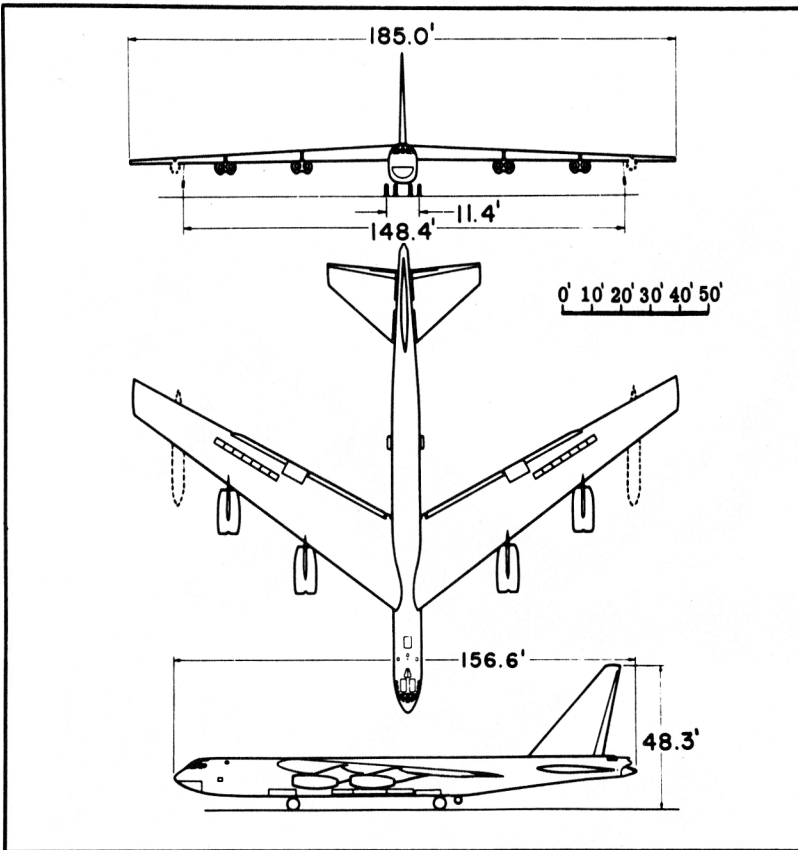

Wing Area 4000 sq ft Wing Section (root) . BAC 233 19.31
 Aspect Ratio 8.55 (tip) . . BAC 236 9.56
 M. A. C. 275.5''

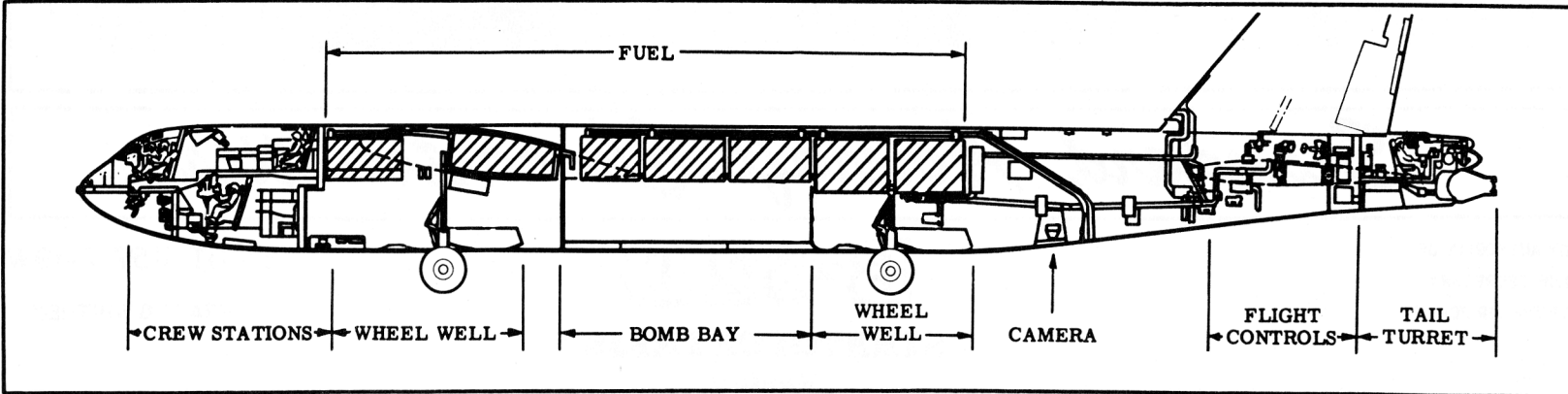
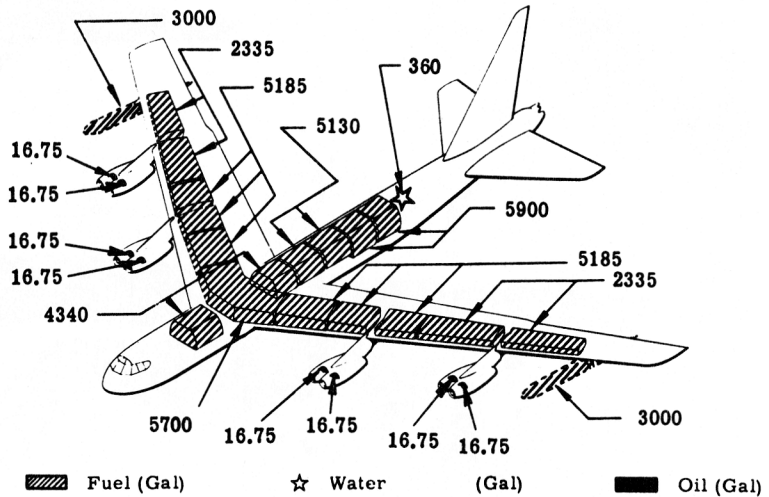
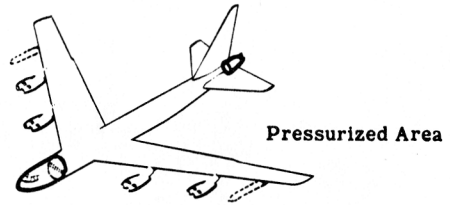

POWER PLANT

No. & Model . . . (8) J57-P-19W
 Mfr Pratt & Whitney
 Engine Spec No. A-1649D
 Type Axial
 Length 157.7"
 Diameter 40.5"
 Weight (dry) 4035 lb
 Tail Pipe Fixed Area
 Augmentation Water

Note: At present there are no requirements for ATO

ENGINE RATINGS

S. L. Static LB- **RPM -MIN

Max: *12,100-6450/9900-5

Mil: 10,500-6150/9900-30

Nor: 9000-5900/9650-Cont

*Wet

**First figure represents low pressure spool; second figure represents high pressure spool.

DIMENSIONS

Wing
 Span 185.0'
 Dihedral (chord plane) . . . 2°30'
 Incidence (root) 6°
 Sweepback (LE) 36°58'
 Length 156.6'
 Height (overall) 48.3'
 Height (fin folded) 20.8'
 Tread (outrigger) 148.4'
 Tread (main gear) 11.4'

Mission and Description

Navy Equivalent: None Mfr's Model: 464-201-6

The principal mission of the B-52D is the destruction of surface objects. The normal crew of six consists of pilot, co-pilot, (2) bombardier-navigators, ECM operator and tail gunner.

Automatic cabin pressurization, heating and ventilation are provided for crew comfort during normal and combat operation.

Ejection seats for emergency escape are afforded the crew except for the tail gunner who bails out after jettisoning the tail section containing the gun turret.

Flight control, throughout the speed range from limit dive speed to landing speed is accomplished by use of spoilers, ailerons on the wing, elevators on an all-movable horizontal tail and a rudder on a fixed vertical tail surface. The spoilers also function as air brakes used in landing.

Thermal anti-icing of wing and tail surface leading edges is accomplished by air being bled off the engines.

Other features are single-point ground and aerial refueling, braking parachute for decreasing landing roll distance, and a steerable landing gear to aid in cross wind take-off and landing. The airplane utilizes the A-14 auto-pilot and the N-1 compass.

The RB-52C (Bomber Version) becomes a RB-52C when the capsule containing photographic equipment is placed in the bomb bay.

Major differences from the RB-52B (Bomber Version) are the installation of J57-P-19W engines in place of J57-P-1W engines and an increase in fuel tank capacities.

Development

The B-52D airplane is same as RB-52C (Bomber Version) except that it does not have the bomb bay (Capsule) convertibility to a reconnaissance characteristic.

Delivery: Five B-52D airplanes are scheduled for delivery Dec 56 (est)

WEIGHTS

Loading	Lb	L. F.
Empty . . .	165,110 (C)	
Basic . . .	167,685	
Design . . .	450,000	2.0
Combat . . .	*279,900	2.4
Max T. O. **	450,000	2.0
Max Land	270,000	

(C) Calculated

* For Basic Mission

** Limited by structure; w/o ATO

FUEL

Location	No. Tanks	Gal
Wg, outbd . . .	2	4670
Wg, ctr	1	5700
Wg, inbd* . . .	4	10,370
Fus, fwd* . . .	2	4340
Fus, ctr* . . .	1	5130
Fus, aft* . . .	1	5900
Wg, drop . . .	2	6000
* Self-Sealing	Total	42,110
Grade		JP-4
Specification		MIL-F-5624A

OIL

Nacelle	8	(tot) 134
Grade		
Specification		MIL-L-7808A
WATER		
Fus, aft	1	360

BOMBS

No.	Class (lb)
	New Series
27	(family of clusters) . 1000
	Special Weapons
1	30,000
2	8600
Max Bomb Load (1)	43,000

Note: Structural provisions for 50,000 lb bomb; space and structural provisions for XB-63

GUNS

No.	Type	Size	Rds ea	Loc
4	M-350	600	Tail, tur

CAMERAS

No.	Type	Lens
1	K-38	36"
1	K-22	6"
	or	
1	K-17C	6"
1	0-15 Radar Recording	

ELECTRONICS

UHF Command Set . . . AN/ARC-34
 Liaison AN/ARC-21X
 IFF AN/APX-6
 Radar Beacon . . . AN/APN-76A
 ECM Trans (2) . . . AN/APT-6
 ECM Trans (1) . . . AN/APT-9
 ECM Trans (2) . . AN/APT-16A
 ECM Recv'r (1) . . . AN/APR-14
 Interphone AN/AIC-10
 Bombing Sys MA-6
 Nav. Recv'r AN/ARN-14
 Fire Control Sys A-3A
 ECM Recv'r (1) . . . AN/ARR-9

see page 6 for additional equip.

Loading and Performance - Typical Mission

C O N D I T I O N S	BASIC MISSION	DESIGN MISSION	MAX BOMB MISSION	FERRY RANGE
TAKE-OFF WEIGHT (lb)	I 450,000	II 450,000	III 450,000	IV 447,500
Fuel at 6.5 lb/gal (grade JP-4) (lb)	266,215	267,615	232,905	273,715
Payload (Bombs) (lb)	10,000	8600	43,000	None
Wing loading (lb/sq ft)	112.5	112.5	112.5	111.9
Stall speed (power off) (kn)	136	136	136	136
Take-off ground run at SL ① (ft)	8350	8350	8350	8300
Take-off to clear 50 ft ① (ft)	10,650	10,650	10,650	10,600
Rate of climb at SL ③ (fpm)	2240	2240	2240	2260
Rate of climb at SL (one eng. out) ② (fpm)	2450	2450	2450	2460
Time: SL to 20,000 ft ③ (min)	11.1	11.1	11.1	11.0
Time: SL to 30,000 ft ③ (min)	18.8	18.8	18.8	18.7
Service ceiling (100 fpm) ③ (ft)	38,050	38,050	38,050	38,150
Service ceiling (one eng. out) ② (ft)	37,550	37,550	37,550	37,650
COMBAT RANGE ④ (n. mi)	—	—	—	7260 ⑦
COMBAT RADIUS ④ (n. mi)	3625	3645	3115	—
Average cruise speed (kn)	457	457	457	457
Initial cruising altitude (ft)	34,750	34,750	34,750	34,850
Target speed ③ (kn)	472	472	472	—
Target altitude (ft)	46,150	46,200	45,050	—
Final cruising altitude (ft)	51,950	51,950	52,000	51,550
Total mission time (hr)	15.93	16.03	13.68	15.93
COMBAT WEIGHT (lb)	279,900	280,750	262,450	191,900
Combat altitude ② (ft)	46,150	46,200	45,050	51,550
Combat speed ② (kn)	489	489	501	501
Combat climb ② (fpm)	700	690	1110	1010
Combat ceiling (500 fpm) ② (ft)	47,350	47,200	48,600	54,300
Service ceiling (100 fpm) ③ (ft)	48,100	48,000	49,400	55,300
Service ceiling (one eng. out) ③ (ft)	46,000	45,900	47,300	53,200
Max rate of climb at SL ② (fpm)	5430	5420	5850	7900
Max speed at 20,000 ft ② ⑤ (kn)	546	546	546	546
Basic speed at 35,000 ft ② (kn)	518	518	519	521
LANDING WEIGHT (lb)	188,400	188,500	187,050	191,900
Ground roll at SL (ft)	2630	2630	2600	2670
Ground roll (auxiliary brake) ⑥ (ft)	2260	2260	2250	2290
Total from 50 ft (ft)	3430	3430	3400	3470
Total from 50 ft (auxiliary brake) ⑥ (ft)	3060	3060	3050	3090

NOTES

- ① T. O. power
- ② Max power
- ③ Normal power
- ④ Detailed descriptions of Radius and Range

- missions are given on page 6
- ⑤ Limited by structure
- ⑥ With drag chute
- ⑦ Tanks carried all the way

Performance Basis:

- (a) Data source: Flight tests on XB-52 and YB-52
- (b) Performance based on data referenced on page 6.

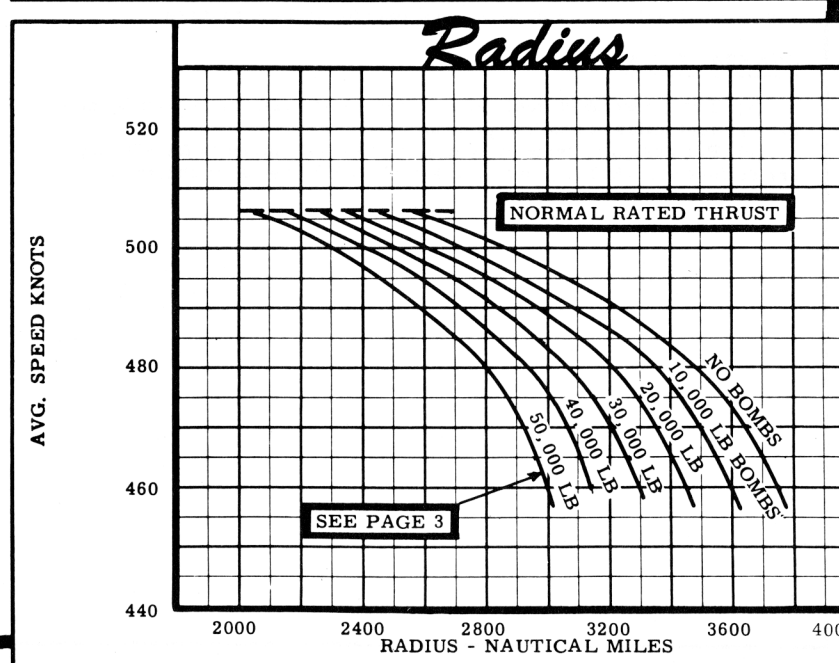
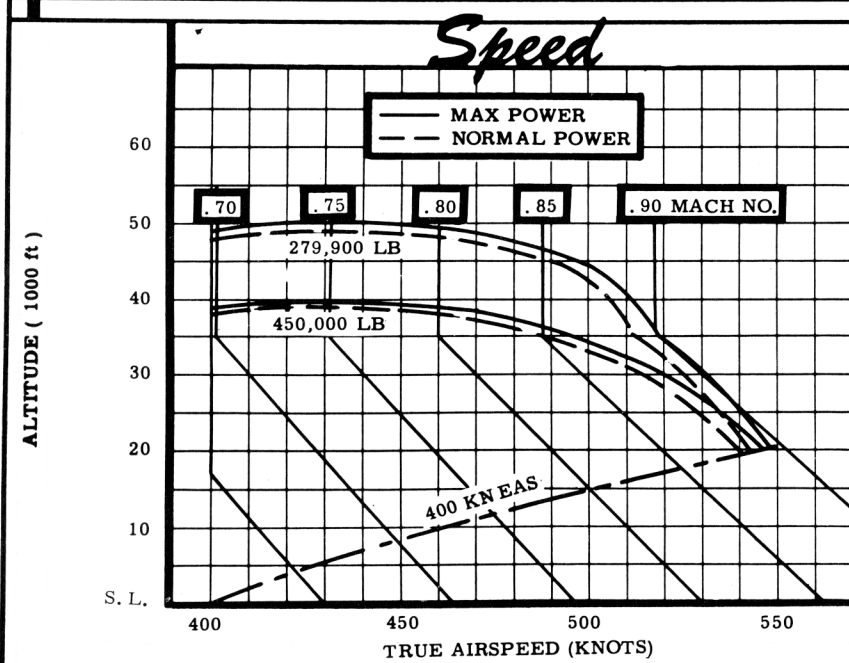
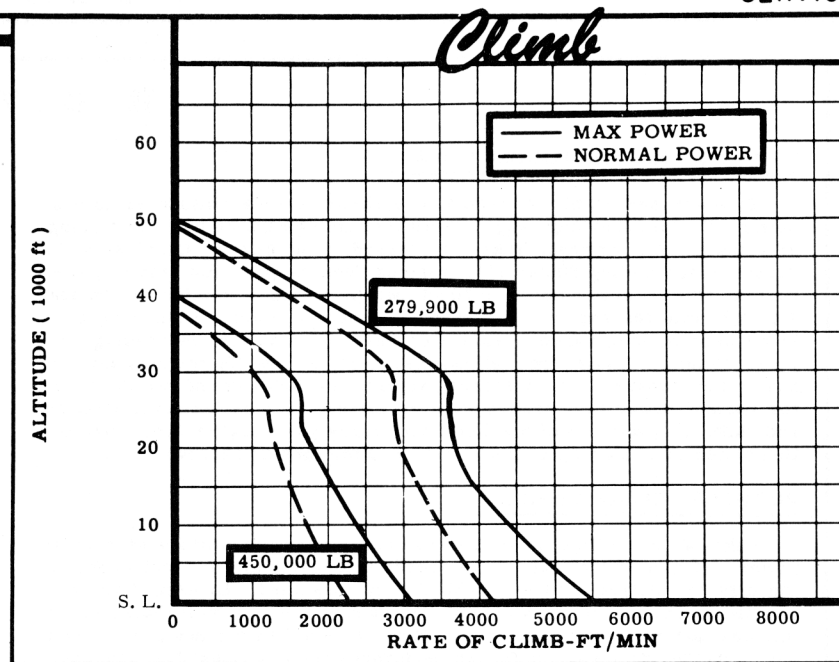
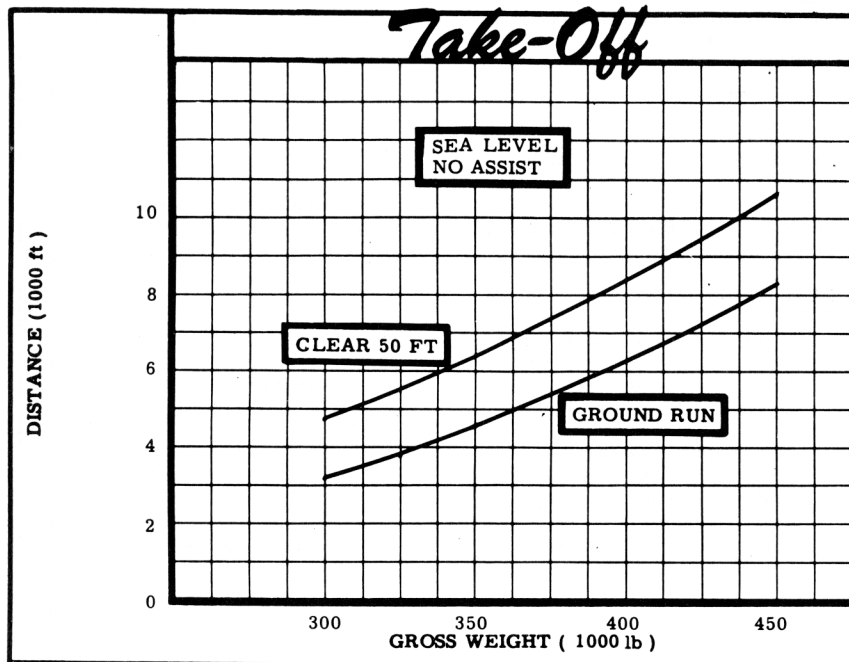

N O T E S

FORMULA: RADIUS MISSIONS I, II & III

Take-off and climb on course to optimum cruise altitude at normal power. Cruise out at long range speeds increasing altitude with decreasing airplane weight, external tanks are dropped, when empty. Climb so as to reach cruise ceiling fifteen (15) minutes from target. Run into target at normal power, drop bombs, conduct two (2) minutes evasive action and eight (8) minutes escape from target at normal power. Cruise back to home base at long range speeds increasing altitude with decreasing airplane weight. Range free allowances include five (5) minutes normal power fuel consumption for starting engines and take-off and two (2) minutes normal power fuel consumption at combat altitude for evasive action and thirty (30) minutes of maximum endurance (four engine) fuel consumption at sea level plus 5% of initial fuel load for landing reserve.

FORMULA: RANGE MISSION IV

Take-off and climb on course to optimum cruise altitude at normal power. Cruise out at long range speeds increasing altitude with decreasing airplane weight until all usable fuel is consumed. External tanks are carried to the end of the mission. Range free allowances include five (5) minutes normal power fuel consumption for starting engines and take-off and thirty (30) minutes of maximum endurance (four engines) fuel consumption at sea level plus 5% of initial fuel load for landing reserve.

GENERAL DATA:

- (a) The prescribed fuel reserve for basic mission is equivalent to 910 nautical miles at best range conditions.
- (b) Per design criteria the minimum take-off distances for 450,000 lb are as follows: 7800 ft ground run and 10,050 ft over 50 ft obstacle.

PERFORMANCE REFERENCE:

Boeing Document No. D-15134, subject "Substantiating Data Report - Model RB-52C Standard Aircraft Characteristics Charts", dated 25 May 1954.

REVISION BASIS:

To reflect latest performance and characteristics data.

The following Electronic equipment is supplemental to that shown under Electronics on Page 3:

Glide Path Receiver	(1)	AN/ARN-18
Direction Finder	(1)	AN/ARA-25
Marker Beacon	(1)	AN/ARN-12
Early Warning	(1)	AN/APS-54
Chaff	(2)	AN/ALE-1

SUPPLEMENTAL

Air Refueled Radius

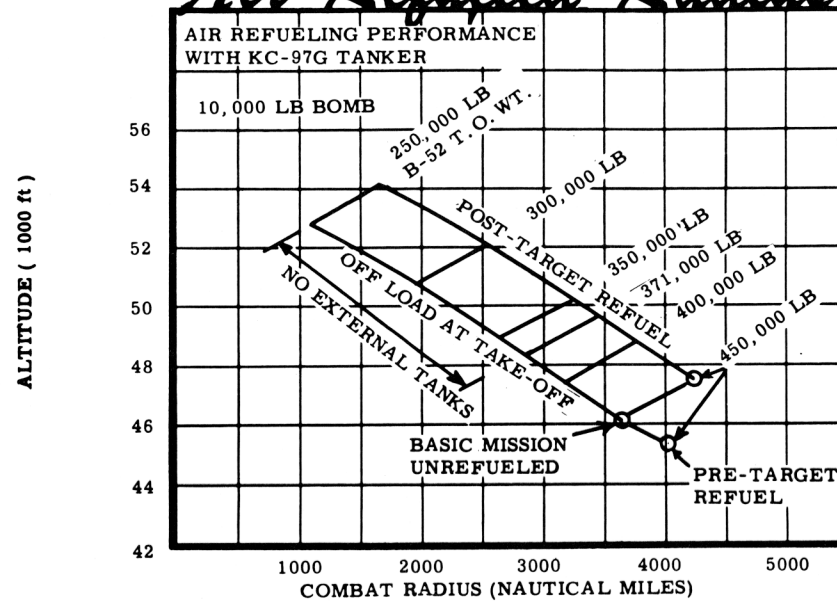

This chart shows alternate 10,000 pound bomb missions available by refueling either before bomb drop, after bomb drop, or by taking off at reduced weights. Aerial refueling with the KC-97G Tanker is accomplished at 25,000 feet altitude with fuel allowance for rendezvous and transfer. No range credit is allowed for descent to 25,000 feet; climb back to cruise altitude is accounted for in range and fuel consumption.

~~C O N F I D E N T I A L~~

Property of the Air Force Museum
Wright-Patterson Air Force Base
Ohio 45433

Property of the Air Force Museum
Wright-Patterson Air Force Base
Ohio 45433

~~C O N F I D E N T I A L~~