

A1
B-52G / Chan

UNCLASSIFIED

SERVICE

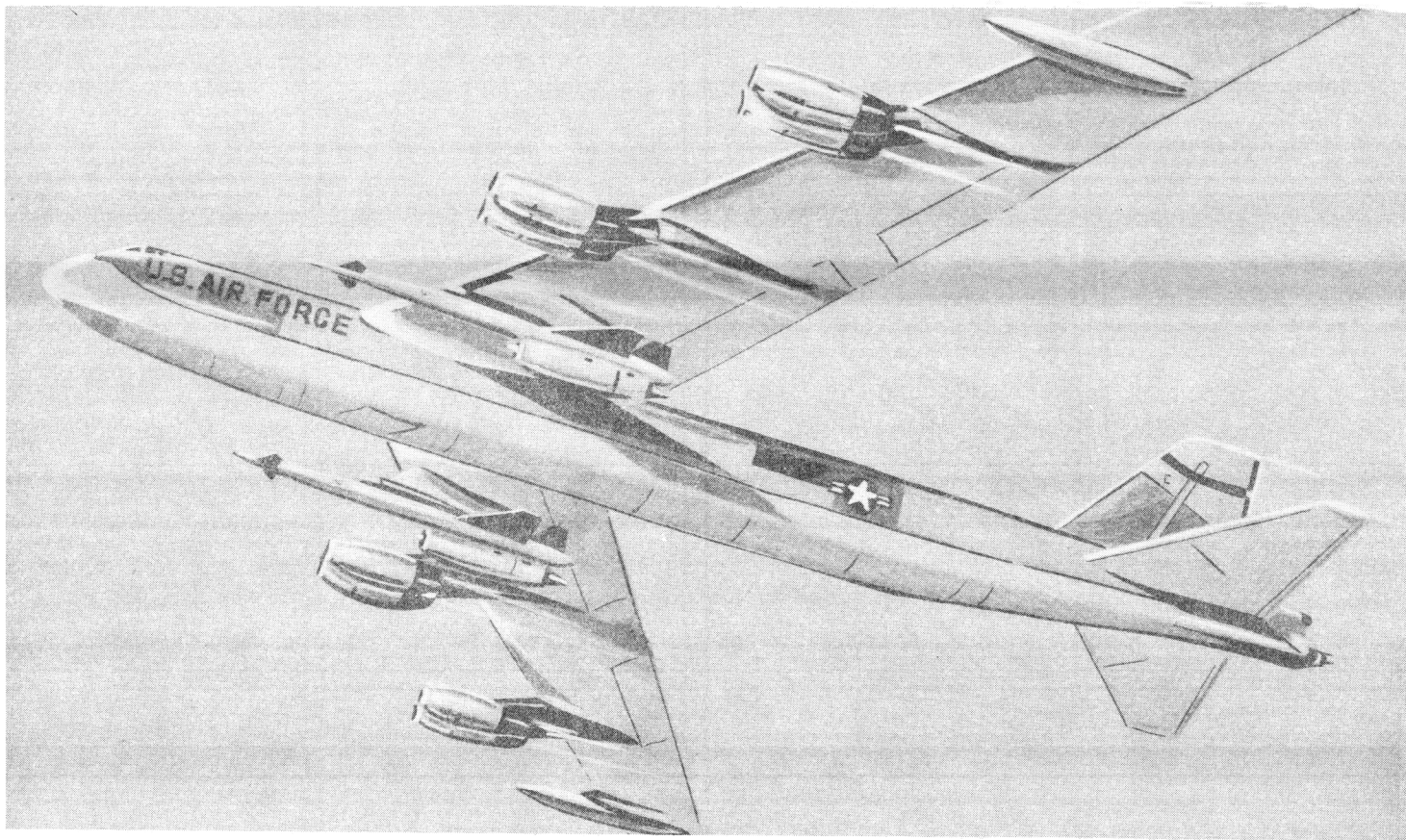

Standard Aircraft Characteristics

BY AUTHORITY OF
THE SECRETARY
OF THE AIR FORCE

B - 5 2 G
STRATOFORTRESS
Boeing

EIGHT J57-P-43WB

PRATT & WHITNEY

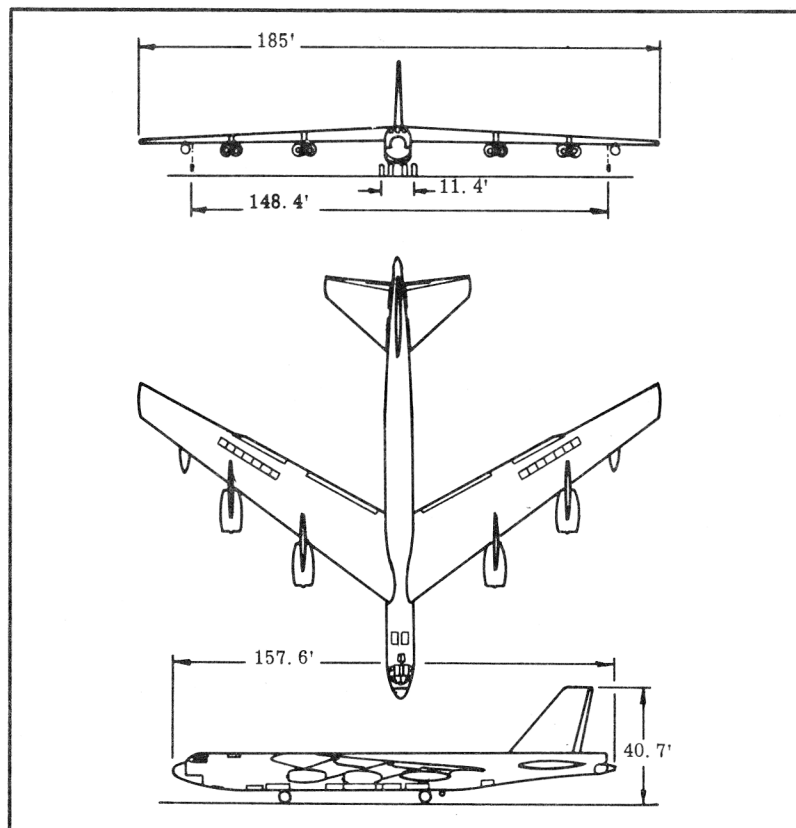

Wing 4000 sq ft Wing Section . . . (root) BAC 233
 (tip) BAC 236
 Aspect Ratio 8.55 M. A. C. 275.5"

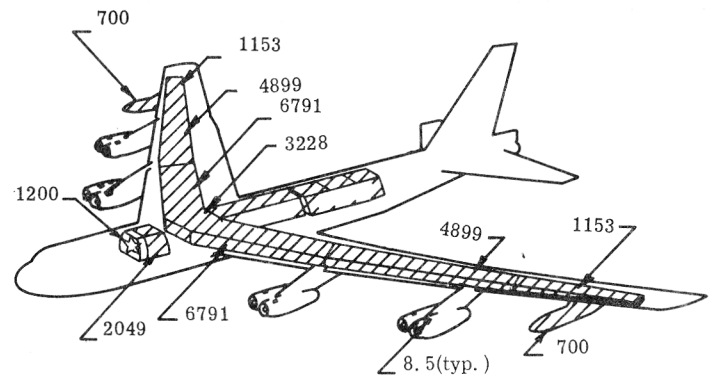
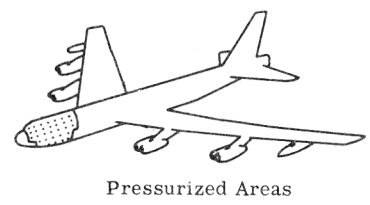

▨ Fuel (Gal) ☆ Water Alcohol (Gal) ▩ Oil (Gal)

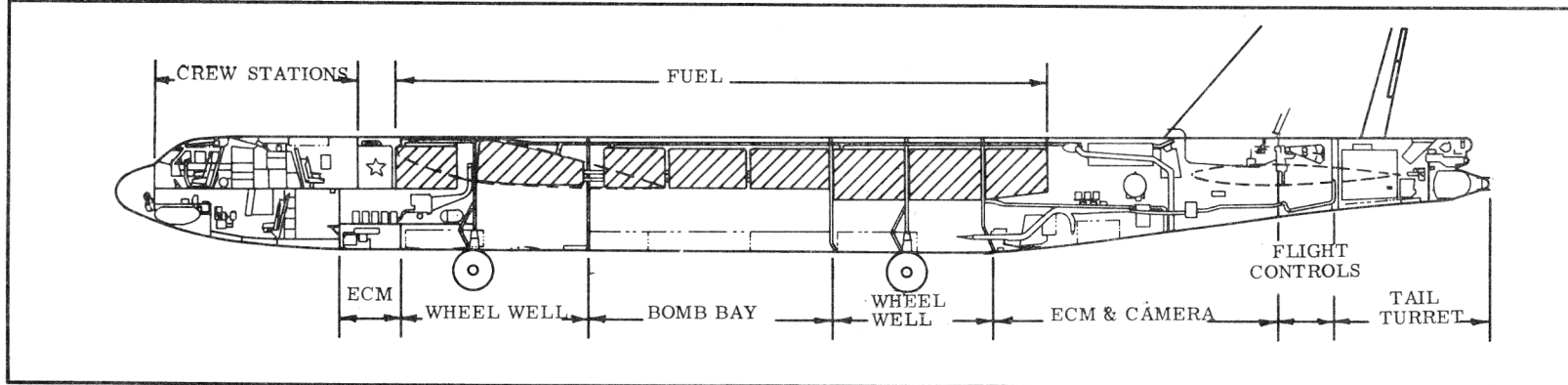

POWER PLANT

Nr & Model..... (8) J57-P-43WB*
 Mfr..... Pratt & Whitney
 Eng. Spec. Nr..... A1704-E
 Type Axial
 Length 167.3 in.
 Diameter 38.9 in.
 Weight (Dry) 3870 lb.
 Tail Pipe Fixed Area
 Augmentation Water

NOTE: There are no requirements for ATO

*Equipped with sound suppressors

ENGINE RATINGS

S. L. Static	LB. — RPM* — MIN
Max: **	13,750 - 6900/9650 - 5
Mil:	11,200 - 6400/9650 - 30
Nor:	9,500 - 6100/9350 - Comt

* First figure represents low pressure spool, second figure represents high pressure spool.

** With water injection (available for T. O. only)

DIMENSIONS

Wing
 Span 185.0'
 Dihedral(chord 2°30'
 plane)
 Incidence (root) 6°
 Sweepback (L.E) 36°58'
 Length 157.6'
 Height(overall) 40.7'
 Height(fln folded) 21.5'
 Tread(outtrigger) 148.4'
 Tread(main gear) 11.4'

Mission and Description

Navy Equivalent: None

Mfr's Model: 464-253

The principal mission of the B-52G is the destruction of surface objectives from high speed and altitude and long range flight. In addition, airplane is equipped to carry four ADM-20 and two AGM-28, missiles, with other loads to within tactical range of the objectives. The normal crew of six consists of pilot, copilot, (2) bombardier-navigators, ECM operator, and gunner.

Automatic cabin pressurization, heating, and ventilation are provided for crew comfort. Ejection seats for emergency escape are provided for all the crew. Flight control is accomplished by use of spoilers on the wing, elevators on the all-movable horizontal tail, and a rudder on the fixed vertical tail. The spoilers also function as airbrakes in descents and landing.

Other features are single-point ground and air refueling, braking parachute for decreasing landing roll distance, steerable landing gear to aid in cross-wind take-off and landing, and a liquid oxygen system. Major differences from the B-52F include reduced span fin, deletion of allerons, 700 gallon fixed external tanks, enlarged nose radome, relocation of the gunner, integral wing fuel tanks, increased maximum gross weight, and reduced operating empty weight.

Development

Design Initiated	Jun 58
First Flight	Oct 58
First Acceptance	Oct 58
Out of Production	Mar 61

WEIGHTS

Loading	LB	L. F.
Empty (C).....	166,555	-
Basic (C).....	168,895	-
Design.....	*500,000	-
Combat.....	**286,366	3.4
Max Takeoff.....	***488,000	1.8
Design In-Flight.....	†450,000	2.0
Alternate		
In-Flight.....	†498,000	1.8
Design Landing.....	270,000	-
(C) Calculated		
* Maximum Taxi Weight		
** For Basic Mission		
*** Excludes 10,000 lb water		
† Limited by Structure		

FUELS

Location	Nr. Tanks	Gal
Wing, Ext.....	2	1400
Wing, Outbd.....	2	2306
Wing, Inbd.....	4	23,416
Wing, Ctr.....	1	3228
Fus, Fwd.....	1	2049
Fus, Mid.....	3	7140
Fus, Aft.....	3	6491
Total		48,030
Grade.....		JP-4
Spec.....		MIL-F-5624A
Nacelle.....	8	Total 66
Grade.....		Synthetic
Spec.....		MIL-L-7808C
Water		
Fus, Fwd.....	1	1200

BOMBS

Nr.	Class (lb)
27 (Family of Clusters)	1000

Special Weapons

MK-6	MK-36
MK-15	MK-39
MK-28	MK-41
	MK-43

NOTE: Airplane carries 4 ADM-20 and 2 AGM-28 missiles.

GUNS

Nr.	Type	Size	Rds. Ea.	Loc
4	M-3	50cal	600	Tail tur.

CAMERAS

Nr.	Type	Lens
1	0-32	Radar Recording
1	K-38	36"
1	K-17C	6' or
1	K-17D	6'

ELECTRONICS

UHF Command Set	AN/ARC-34
Aux. UHF Radio	AN/ARC-34
Liaison	AN/ARC-58
Bomb Nav. System	AN/ASB-9 & AN/ASB-16
Emergency Keyer	AN/ARA-26
Interphone	AN/AIC-10A
Omni Range Receiver	AN/ARN-14
Glide Path Receiver	AN/ARN-31
Marker Beacon Receiver	AN/ARN-32
IFF (air to ground)	AN/APX-25A
Radar Beacon	AN/APN-69
ECM Trans (3)	AN/ALT-6B
ECM Recv'r (2)	AN/APR-9
ECM Recv'r	AN/APR-14
TACAN	AN/ARN-21

See page 8 for additional equipment

Loading and Performance - Typical Mission

C O N D I T I O N S	BASIC MISSION I	DESIGN LOAD II	MAX. BOMB LOAD III	FERRY RANGE IV	ALTERNATE LOAD V	MISSILE LOAD VI
TAKEOFF WEIGHT	450,000	450,000	450,000	450,000	450,000	450,000
Fuel at 6.5 lb/gal (Grade JP-4) ⑤ ⑦ (lb)	267,570	259,870	241,392	278,240	268,970	228,781
Payload (Bombs) (lb)	10,000	17,700	35,400	0	8600	17,700
Payload (Chaff) (lb)	400	400	400	0	400	400
Payload (Flares) (lb)	270	270	270	0	270	270
Payload (Missiles) (lb)	---	---	---	---	---	25,736 ⑩
Wing Loading (lb/ft ²)	112.5	112.5	112.5	112.5	112.5	112.5
Stall speed (Power off) ⑧ (kn)	147	147	147	147	147	147
Take-off Ground run at S. L. ① (ft)	6750	6750	6750	6750	6750	5950 ⑨
Take-off to clear 50 ft ① (ft)	8800	8800	8800	8800	8800	7750 ⑨
Rate of climb at S. L. ③ (fpm)	2350	2350	2350	2350	2350	2620 ⑩
Rate of climb at S. L. (one engine out) ② (fpm)	2640	2640	2640	2640	2640	2910 ⑩
Time: S. L. to 20,000 ft ③ (min)	10.4	10.4	10.4	10.4	10.4	9.3 ⑩
Time: S. L. to 30,000 ft ③ (min)	17.3	17.3	17.3	17.3	17.3	15.5 ⑩
Service ceiling (100 fpm) ③ (ft)	38,000	38,000	38,000	38,000	38,000	38,650 ⑩
Service ceiling (one engine out) ② (ft)	37,500	37,500	37,500	37,500	37,500	38,200 ⑩
COMBAT RANGE ④ (n. mi)	---	---	---	6955	---	---
COMBAT RADIUS ④ (n. mi)	3315	3210	2955	---	3330	2660 ⑩
Average cruise speed (kn)	454	454	454	454	454	454
Initial cruising altitude (ft)	33,450	33,450	33,450	33,450	33,450	33,400
Target speed ③ (kn)	473	473	473	---	473	471
Target altitude (ft)	45,300	45,050	44,500	---	45,350	45,750
Final cruising altitude (ft)	50,550	50,600	50,600	50,500	50,550	50,150
Total mission time (hr)	14.5	14.1	13.9	15.4	14.6	11.8
COMBAT WEIGHT (lb)	286,366	282,387	273,757	191,077	287,097	270,530
Combat altitude (ft)	45,300	45,050	44,500	50,450	45,350	45,750
Combat speed ② (kn)	493	496	502	508	492	498
Combat climb ② (fpm)	735	855	1090	1400	705	845
Combat ceiling (500 fpm) ② (ft)	46,600	46,950	47,600	54,600	46,600	47,700
Service ceiling (100 fpm) ③ (ft)	47,250	47,550	48,200	55,000	47,200	48,300
Service ceiling (one engine out) ③ (ft)	45,400	45,650	46,300	53,400	45,300	46,400
Max. rate of climb at S. L. ② (fpm)	5600	5675	5875	8425	5575	5890
Max. speed at optimum altitude ② ⑤ (kn/ft)	551/20,800	551/20,800	551/20,800	552/20,900	551/20,800	551/20,800
Basic speed at 35,000 ft ② (kn)	521	521	522	526	521	522
LANDING WEIGHT (lb)	190,526	190,131	189,981	191,077	190,576	194,082
Ground roll at S. L. (ft)	2175	2175	2175	2175	2175	2210
Ground roll (auxiliary brake) ⑥ (ft)	1950	1950	1950	1950	1950	1995
Total from 50 ft (ft)	3810	3810	3810	3810	3810	3880
Total from 50 ft (auxiliary brake) ⑥ (ft)	3575	3575	3575	3575	3575	3620

N O T E S	① Take-off power	⑥ With drag chute	⑩ 4 ADM-20's 4840 lb Droppable racks 590 lb 2 AGM-28's 20,306 lb Total 25,736 lb
	② Military power	⑦ Does not include 10,000 lb water	
	③ Normal power	⑧ Initial buffet, flaps down, S. L.	
	④ Detailed descriptions of radius and range mission are given on page 8	⑨ AGM-28's at take-off power	
	⑤ Limited by structure (load factor = 2.0)	⑩ AGM-28's at maximum continuous power	

PERFORMANCE BASIS:
(a) Data Source: Flight Test

Loading and Performance—Typical Mission

C O N D I T I O N S	BASIC MISSION I	DESIGN LOAD II	MAX BOMB LOAD III	FERRY RANGE IV	ALTERNATE LOAD V	MISSILE LOAD VI
TAKE-OFF WEIGHT (7) (lb)	488,000 (5)	488,000 (5)	488,000 (5)	483,955 (8)	488,000 (5)	488,000 (5)
Fuel at 6.5 lb/gal (Grade JP-4) (lb)	305,570	297,850	279,392	312,195	306,970	266,781
Payload (Bombs) (lb)	10,000	17,700	35,400	0	8600	17,700
Payload (Chaff) (lb)	400	400	400	0	400	400
Payload (Flares) (lb)	270	270	270	0	270	270
Payload (Missiles) (lb)	---	---	---	---	---	25,736 (12)
Wing loading (lb/ft ²)	122.0	122.0	122.0	121.5	122.0	122.0
Stall speed (power off) (9) (kn)	153	153	153	153	153	153
Take-off ground run at S. L. (1) (ft)	8150	8150	8150	8000	8150	7150 (10)
Take-off to clear 50 ft (1) (ft)	10,400	10,400	10,400	10,225	10,400	9150 (10)
Rate of climb at S. L. (3) (fpm)	2100	2100	2100	2125	2100	2350 (11)
Rate of climb at S. L. (one engine out) (2) (fpm)	2360	2360	2360	2390	2360	2610 (11)
Time: S. L. to 20,000 ft (3) (min)	11.8	11.8	11.8	11.6	11.8	10.5 (11)
Time: S. L. to 30,000 ft (3) (min)	20.0	20.0	20.0	19.7	20.0	17.8 (11)
Service ceiling (100 fpm) (3) (ft)	36,250	36,250	36,250	36,450	36,250	36,900 (11)
Service ceiling (one engine out) (2) (ft)	35,700	35,700	35,700	35,900	35,700	36,450 (11)
COMBAT RANGE (4) (n mi)	---	---	---	7665	---	---
COMBAT RADIUS (4) (n mi)	3645	3545	3305	---	3660	2995 (11)
Average cruise speed (kn)	454	454	454	454	454	454
Initial cruising altitude (ft)	31,700	31,700	31,700	31,900	31,700	31,700
Target speed (kn)	473	473	473	---	471	471
Target altitude (ft)	44,400	44,150	43,600	---	44,450	44,800
Final cruising altitude (ft)	50,350	50,350	50,400	50,300	50,350	49,950
Total mission time (hr)	16.0	15.5	14.4	17.0	16.0	13.2
COMBAT WEIGHT (lb)	300,598	296,524	287,948	192,810	301,363	284,259
Combat altitude (ft)	44,400	44,150	43,600	50,300	44,450	44,800
Combat speed (2) (kn)	492	496	502	508	492	497
Combat climb (2) (fpm)	725	850	1110	1390	710	825
Combat ceiling (500 fpm) (2) (ft)	45,600	45,900	46,500	54,450	45,550	46,650
Service ceiling (100 fpm) (3) (ft)	46,200	46,500	47,100	54,900	46,100	47,240
Service ceiling (one engine out) (3) (ft)	44,400	44,650	45,250	53,250	44,350	45,400
Max. rate of climb at S. L. (2) (fpm)	5300	5400	5550	8350	5300	5600
Max. speed at optimum altitude (2,5) (kn/ft)	551/20,800	551/20,800	551/20,800	552/20,900	551/20,800	551/20,800
Basic speed at 35,000 ft (2) (kn)	520	520	521	526	520	521
LANDING WEIGHT (lb)	192,475	192,080	191,930	192,810	192,546	196,031
Ground roll at S. L. (ft)	2200	2200	2200	2200	2200	2230
Ground roll (auxiliary brake) (6) (ft)	1975	1975	1975	1975	1975	2015
Total from 50 ft (ft)	3850	3850	3850	3850	3850	3900
Total from 50 ft (auxiliary brake) (6) (ft)	3600	3600	3600	3600	3600	3670

N O T E S	(1) Take-off power	(6) With drag chute	(12) 4 ADM-20's 4840 lb	PERFORMANCE BASIS: (A) Data Source: Flight Test
	(2) Military power	(7) Does not include 10,000 lb. water	Droppable racks 590 lb	
	(3) Normal power	(8) Limited by fuel capacity	2 AGM-28's 20,306 lb	
	(4) Detailed descriptions of radius and range missions are given on page 8	(9) Initial buffet, flaps down, S. L.	Total 25,736	
(5) Limited by structure (load factor = 1.9)	(10) AGM-28's at take-off power	(11) AGM-28's at maximum continuous power		

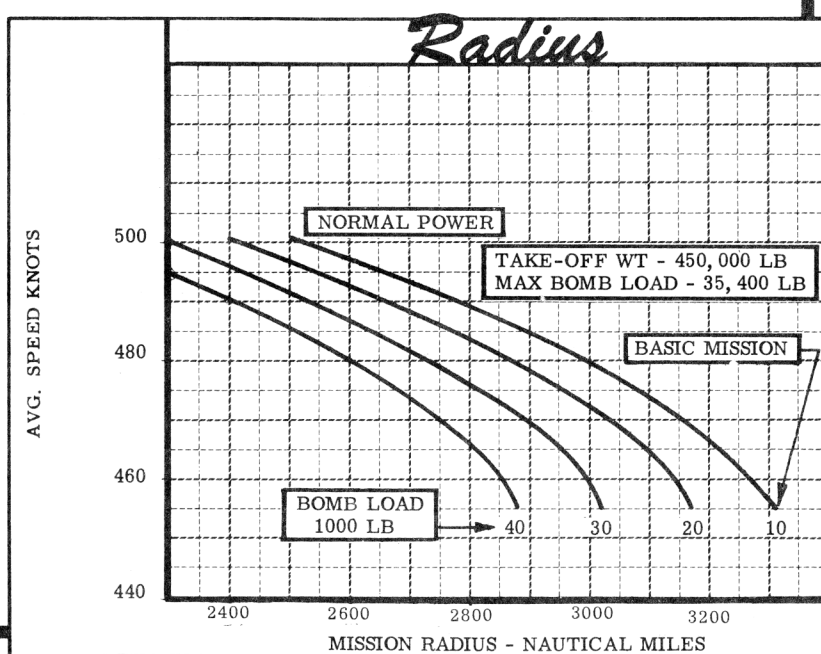
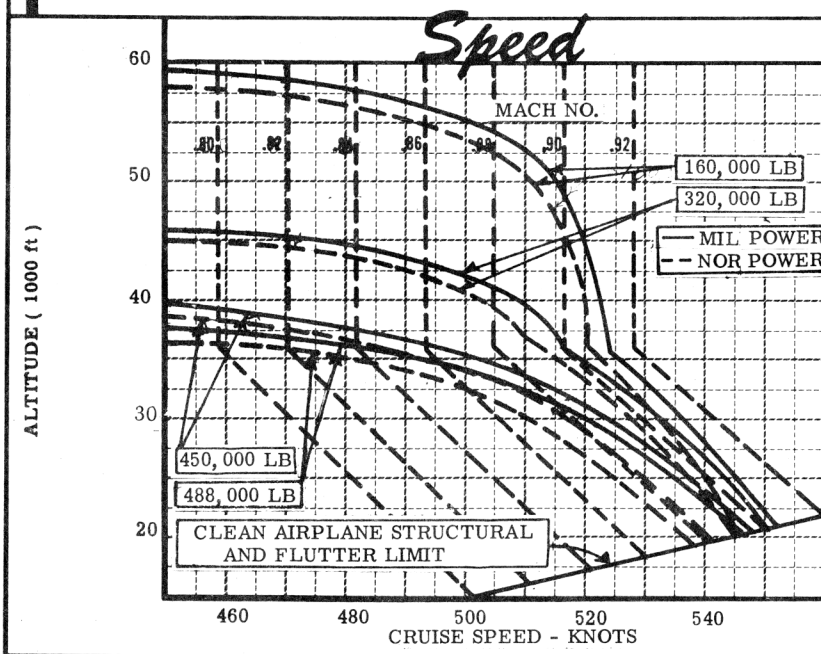
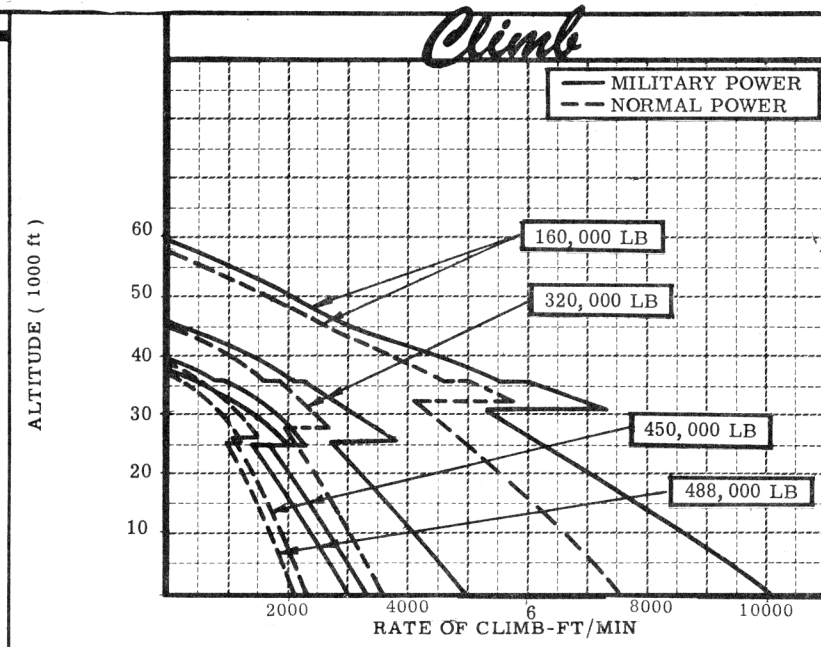
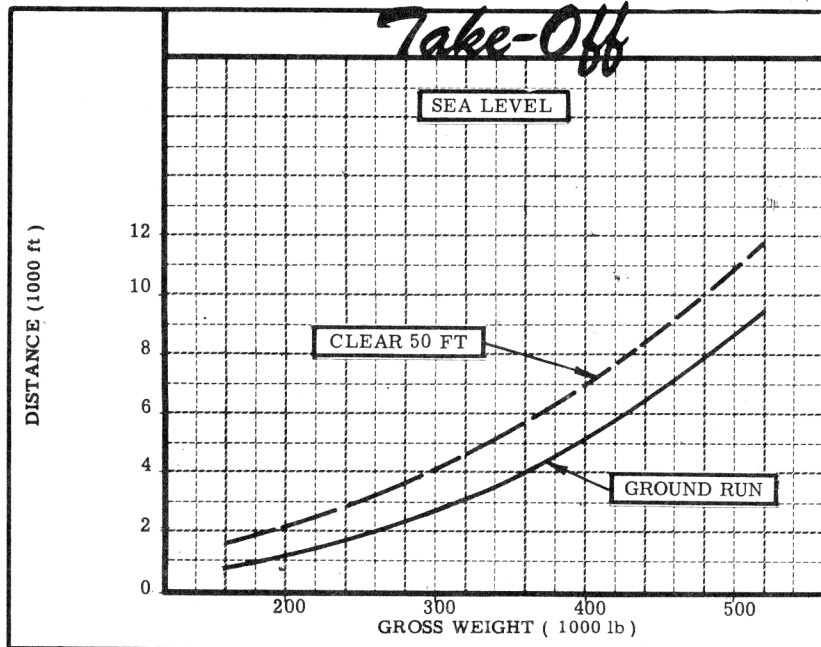

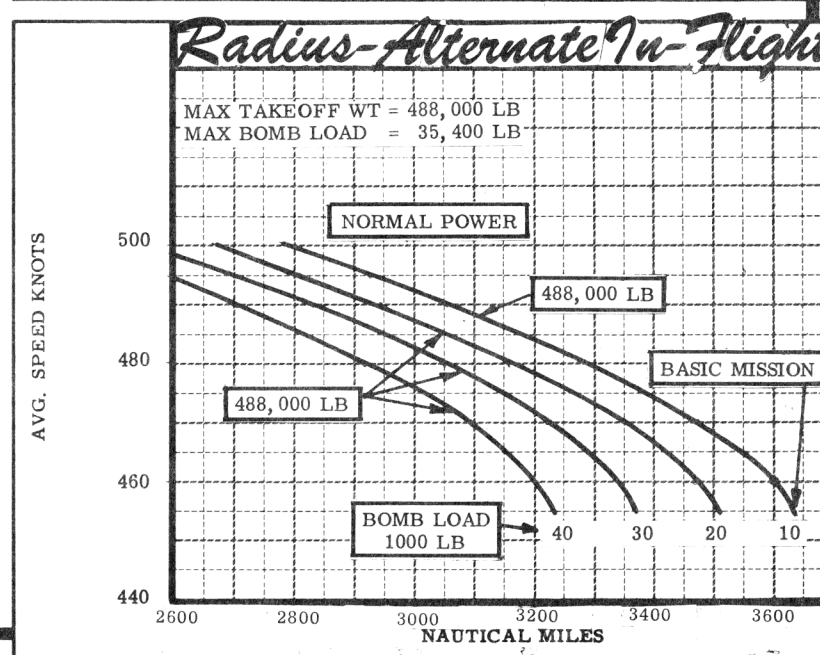
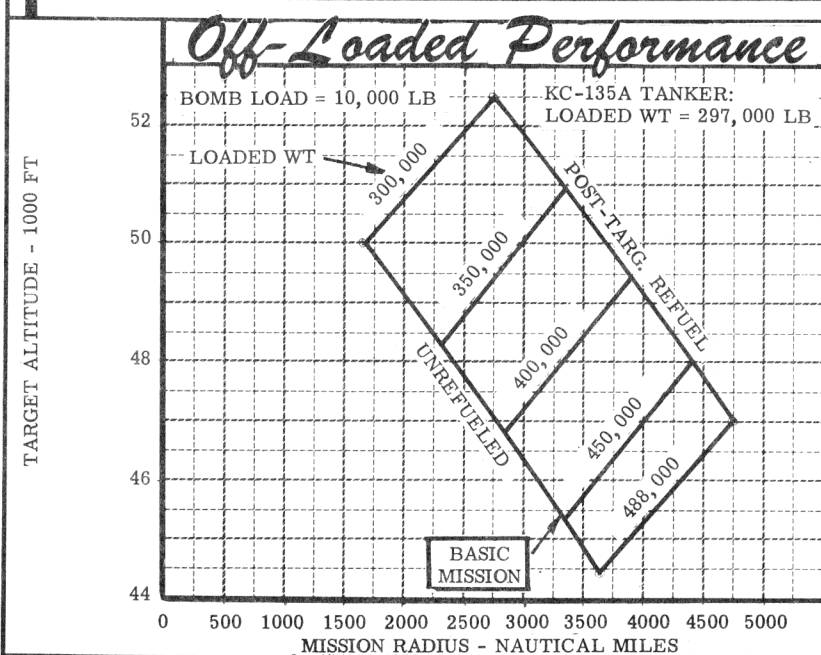
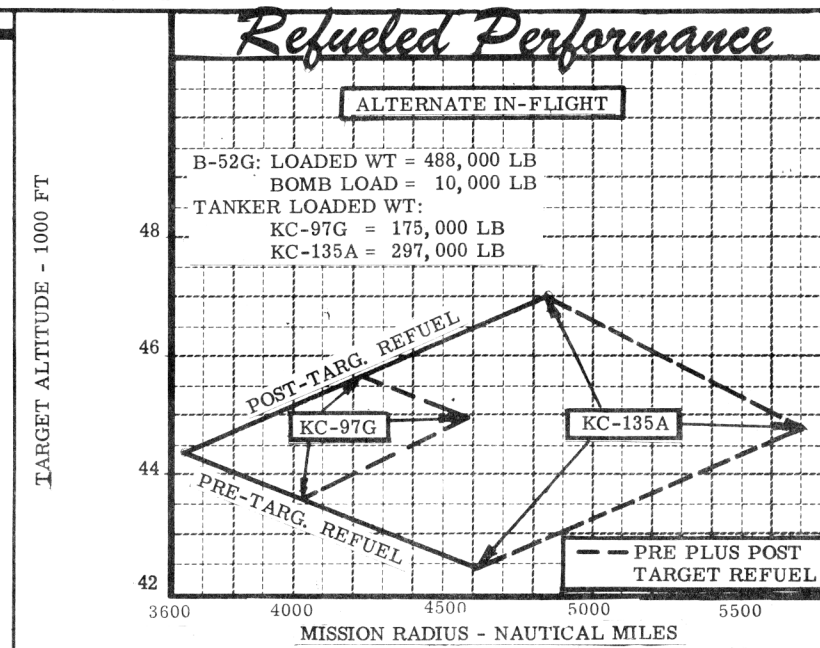
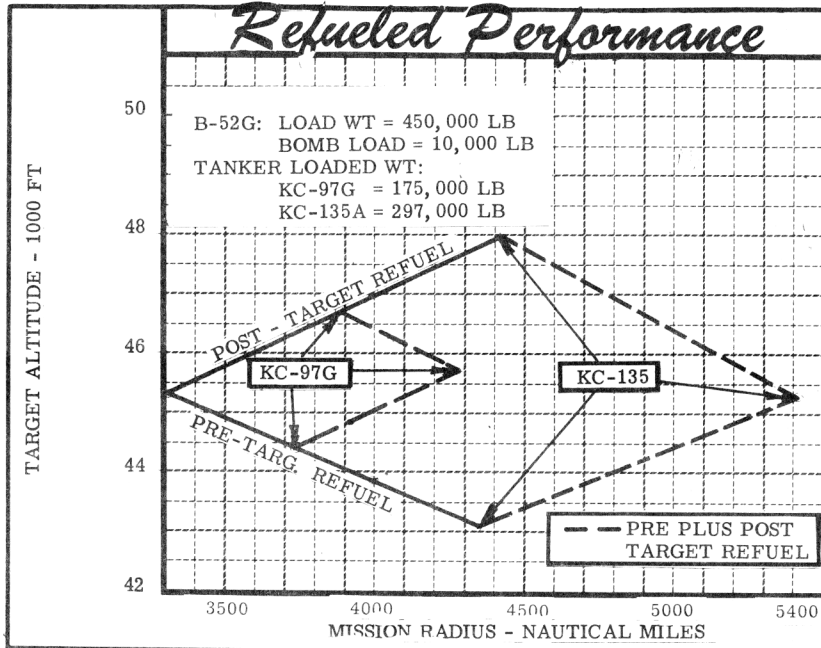

N O T E S

FORMULA: BOMBER RADIUS MISSIONS I, II, III & V

Take off and climb on course to optimum-cruise altitude at normal power. Cruise out at long range speed*, increasing altitude with decreasing weight. Climb so as to reach cruise ceiling 15 minutes from target. Run into target at normal power, drop bombs, conduct 2 minutes evasive action, and 8 minutes escape at normal power. Cruise back to home base at long range speeds*, increasing altitude with decreasing airplane weight. Range-free allowances include 5 minutes normal power fuel consumption for starting engines and take off, 2 minutes normal power fuel consumption at combat altitude for evasive action, and 30 minutes of maximum-endurance (four engines) fuel consumption at sea level plus 5% of initial fuel for landing reserve.

FORMULA: BOMBER RANGE MISSION IV

Take off and climb on course to optimum-cruise altitude at normal power. Cruise out at long range speeds*, increasing altitude with decreasing weight, until all fuel is consumed. Range-free allowances include 5 minutes normal power fuel consumption for starting engines and take off, and 30 minutes of maximum-endurance (four engines) fuel consumption at sea level plus 5% of initial fuel for landing reserve.

FORMULA: BOMBER RADIUS MISSION VI

Take off and climb on course to optimum-cruise altitude at normal power (AGM-28's at maximum continuous power). Cruise out at long range speed*, increasing altitude with decreasing weight. Release AGM-28's and ADM-20's at their respective ranges from bomb target. Climb so as to reach cruise ceiling 15 minutes from target. Run into target at normal power, drop bombs, conduct 2 minutes evasive action, and 8 minutes escape at normal power. Cruise back to home base at long range speeds*, increasing altitude with decreasing airplane weight. Range-free allowances include 5 minutes normal power fuel consumption for starting engines and take-off, 2 minutes normal power fuel consumption at combat altitude for evasive action, and 30 minutes of maximum-endurance (four engines) fuel consumption at sea level plus 5% of initial fuel for landing reserve.

*Long range speed is maximum speed for 99% maximum miles per pound of fuel.

Property of the Air Force Museum
Wright-Patterson Air Force Base
Ohio 45433

GENERAL DATA

(a) The prescribed fuel reserve for the Basic Missions is equivalent to the following reserve range at 99% maximum range conditions:

B-52G Bomber	808 nautical miles
	884 nautical miles (Alternate In-Flight)

(b) Data based on engine surge bleed valve governors with T. O. 2JA6-3-7-506 incorporated. For airplanes which do not have this T. O. incorporated, reduce mission radius and range numbers by 2%.

(c) The following electronic equipment is supplemental to that shown under "Electronics" on page 3:

ECM Radar Warning	APS-54
Flare Dispenser	Boeing Spec 10-30063
Automatic Astro Compass	MD-1
True Head, Comp Gr	AN/AJA-1
Ground Speed & Drift Radar	AN/APN-89A
Early Warning Radar (3)	AN/APS-54
Chaff Dispenser (2)	AN/ALE-1 or AN/ALE-24 (Complete Prov. Only)
Emergency Sea Rescue	AN/CRT-3
VGH Signal Data Recording Set	A/24U-3
Forward Surveillance Radar	AN/APN-89A
Fire Control System	AN/ASG-15
Auto Flight Control	A/A42G-11
Rec'v'r Trans (2)	AN/ALR-18
ECM Trans (4)	AN/ALT-13
ECM Trans (3)	AN/ALT-15
ECM Trans (1)	AN/ALT-16
Com Pass System	N-1

PERFORMANCE REFERENCE:

Boeing Document D2-2159, "Substantiating Data Report - Models B-52G (J57-P-43WB engines), Standard Aircraft Characteristics Charts."

REVISION BASIS:

To reflect current characteristics and performance data. Data re-ordinated by OCAMA Jul 64. Additional electronics shown.