

AIRPLANE CHARACTERISTICS & PERFORMANCE

COLUMN NUMBER		1	2	3	4
LOADING CONDITION		FIGHTER	FIGHTER	FIGHTER	FIGHTER
GROSS WEIGHT	LBS.	17508	17508	19515	21691
EMPTY WEIGHT - ESTIMATED -	LBS.	13519			
FUEL/OIL	GALS.	384/22	384/22	654/36	954/40
FIXED GUNS/AMMUNITION		6-.50 cal./2400 rds			
FLEXIBLE GUNS/AMMUNITION		None			
ENGINE POWER USED FOR PERFORMANCE		MILITARY	NORMAL	NORMAL	NORMAL
WING LOADING	LBS./SQ.FT.	35.6	35.6	39.8	44.3
POWER LOADING ①	LBS./BHP.	6.9	7.8	8.7	9.6
V-MAX. SEA LEVEL	MPH.	340	319	318	305
V-MAX. AIRPLANE CRIT. ALT.	MPH.	411/26900	399/26400	396/26300	375/26100
V-STALL GROSS WEIGHT ②	MPH.	82.3	82.3	86.8	92.5
V-STALL. WITHOUT FUEL ②	MPH.	76.6	76.6	77.6	79.4
TIME-TO-CLIMB -10000FT-	MIN.	3.8	4.6	5.4	6.4
TIME-TO-CLIMB -20000FT-	MIN.	8.1	9.8	11.6	14.2
SERVICE CEILING	FT.	35,300	34,500	33,000	30,900
TAKE-OFF DISTANCE -CALM-	FT.	639	639	825	1110
TAKE-OFF DISTANCE -15 KN-	FT.	415	415	550	760
TAKE-OFF DISTANCE -25 KN-	FT.	293	293	397	563
TAKE-OFF TIME	SECONDS				
RATE OF CLIMB -SL-	FT./MIN.	2800	2190	1900	1590
MAX. RANGE/V-AV. ③	STMI/MPH.		1305/162	2100/174	2780/171
BOMBING RADIUS/V-AV -20%R-	NMI/KN.				
BOMBING RADIUS/V-AV -33%R-	NMI/KN.				
PATROL RADIUS/V-AV -20%R-	NMI/KN.				
PATROL RADIUS/V-AV -33%R-	NMI/KN.				
SCOUT RADIUS	N MI.				
COMBAT RADIUS	N MI.		170	515	850
ENGINE / PROP. GEAR RATIO		P. & W. XR-4360-10 (.381)			
ENGINE RATING BHP/RPM/ALT.	MILITARY	NORMAL		TAKE-OFF	
	3000/2700/S. L. -1500'	2500/2550/S. L.			
	2750/2700/14500'	2380/2550/14500'		3000/2700	
	2540/2700/22000'	2250/2550/23000'			
TANKAGE IN GALLONS		OIL	FUEL	OFFENSIVE ARMAMENT	
AUX. FIXED	PROTECTED		384	FUSELAGE BOMB-BAY:	
	UNPROTECTED	40		Bombs: 1-2000#, 2-1600#, 2-1000#, or 4-500#	
	TOTAL - FIXED INTERNAL	40	384	WINGS: (external)	
	DROPPABLE - WINGS - 2@150 -		300	Bombs: 2-2000#, 2-1600#, 2-1000#, or 2-500#	
	DROPPABLE Bomb-bay - S. S. -		270	Torpedoes: 2MK13-3	
TOTAL	40	954	NOTE: Two wing bomb-racks are available for either bombs, torpedoes or 2-150 gal. dropp. tanks. Bombs cannot be carried internally with bomb-bay tank installed.		
NOTE	STATUTE MILES USED-EXCEPT-RADIUS IS GIVEN IN NAUTICAL MILES & KNOTS				
	① BHP AT MAX. CRIT. ALT.				
	② STALL-WITHOUT POWER				
③ AT 1500' ALTITUDE					

NAVAER-1519B (Rev. 4-44)

AIRPLANE CHARACTERISTICS & PERFORMANCE

BUREAU OF AERONAUTICS, NAVY DEPT.

COLUMN NUMBER		5	6	7	8
LOADING CONDITION		BOMBER 2-1000#	BOMBER 2-1000# One Tank External	TORPEDO 2MK13-3	TORPEDO 1MK13-3 One B. B. Tank
GROSS WEIGHT	LBS.	19578	20711	21938	21730
EMPTY WEIGHT - Estimated -	LBS.	13519			
FUEL/OIL	GALS.	384/22	534/30	384/22	654/36
FIXED GUNS/AMMUNITION		6-.50 cal./2400 rds.			
FLEXIBLE GUNS/AMMUNITION		None			
ENGINE POWER USED FOR PERFORMANCE		NORMAL	NORMAL	NORMAL	NORMAL
WING LOADING	LBS./SQ.FT.	40.0	42.2	44.6	44.4
POWER LOADING ①	LBS./BHP	9.7	9.2	9.7	9.6
V-MAX. SEA LEVEL	MPH.	318	311	287	300
V-MAX. AIRPLANE CRIT. ALT.	MPH.	396/26300	385/26200	351/25800	369/26,600
V-STALL. GROSS WEIGHT ②	MPH.	86.9	89.9	93.0	92.5
V-STALL. WITHOUT FUEL ②	MPH.	81.6	82.7	88.0	83.8
TIME-TO-CLIMB -10000FT.-	MIN.	5.4	5.9	6.7	6.5
TIME-TO-CLIMB -20000FT.-	MIN.	11.6	12.9	14.8	14.3
SERVICE CEILING	FT.	33,000	31,100	30,700	31,000
TAKE-OFF DISTANCE -CALM-	FT.	830	971	1179	1122
TAKE-OFF DISTANCE -15 KN.-	FT.	553	656	809	769
TAKE-OFF DISTANCE -25KN.-	FT.	400	481	602	569
TAKE-OFF TIME	SECONDS.				
RATE OF CLIMB -SL-	FT./MIN.	1900	1720	1530	1570
MAX. RANGE /V-AV. ③	ST.MI./MPH.	1187/181	1575/178	955/173	1790/172
BOMBING RADIUS/V-AV -20%R-	NMI./KN.				
BOMBING RADIUS/V-AV -33%R-	NMI./KN.				
PATROL RADIUS/V-AV -20%R-	NMI./KN.				
PATROL RADIUS/V-AV -33%R-	NMI./KN.				
SCOUT RADIUS	NMI.				
COMBAT RADIUS	NMI.	215	395	175	520

PERFORMANCE IS BASED ON- CALCULATIONS

RANGE & RADIUS ARE BASED ON ENGINE REQUIREMENT

FUEL CONSUMPTION DATA INCREASED

BY 15 PERCENT TO CONFORM WITH PAST EXPERIENCE.

FOR CONDITIONS ONE THRU FOUR:

PRACTICAL COMBAT RADIUS is based on 20 min. warm up and idle; 1 min. take off; 20 min. rendezvous at 60% normal sea level power (n.s.p.) and auto lean; climb to 15000 ft. at 60% n.s.p. and auto rich; cruise out at V for max. range and auto lean; drop bombs and unprotected droppable tanks; combat at 15000 ft. for 10 min. at full military power plus 10 min. at full normal power; descend; cruise back at 1500 ft. at 170 knots true air speed and auto lean; 60 min. at V for max. range and auto lean allowance for rendezvous, landing and reserve. Radius includes distance covered in climb but not in descent.

FOR CONDITIONS FIVE THRU EIGHT:

PRACTICAL COMBAT RADIUS is based on 20 min. warm up and idling; one min. take off; 20 min. rendezvous at 60% normal sea level power (n.s.p.) and auto lean; climb to 15000 ft. at 60% n.s.p. and auto rich; cruise out at 180 knots and auto lean; drop unprotected droppable tanks; dive; drop bombs and torpedoes; combat at 1500 ft. for 5 min. at full military power plus 10 min. at full normal power; cruise back at 1500 ft. at 170 knots true air speed and auto lean; 60 min. at V for max. range and auto lean allowed for rendezvous, landing and reserve. Radius includes distance covered in climb but not in descent.

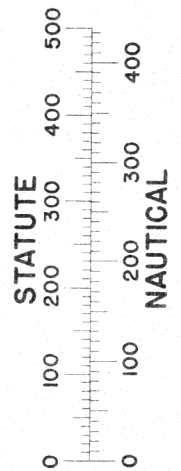
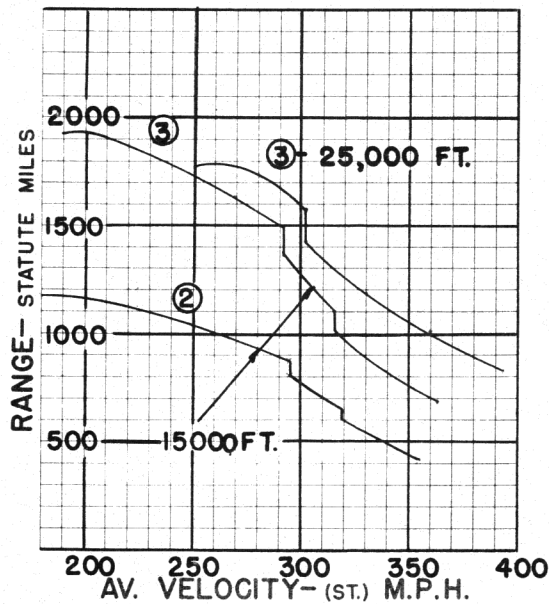
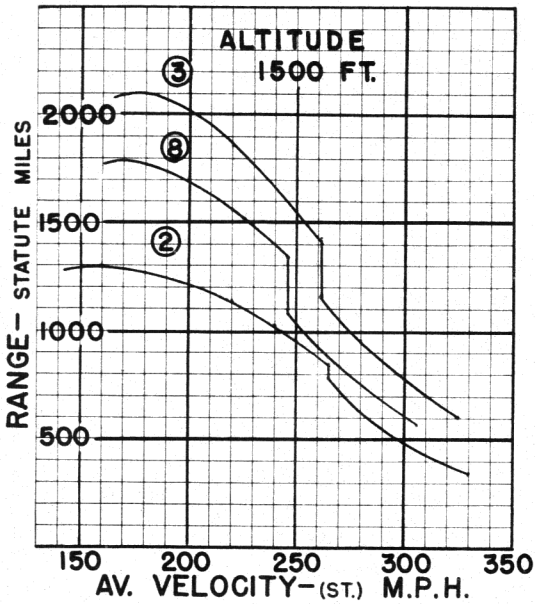
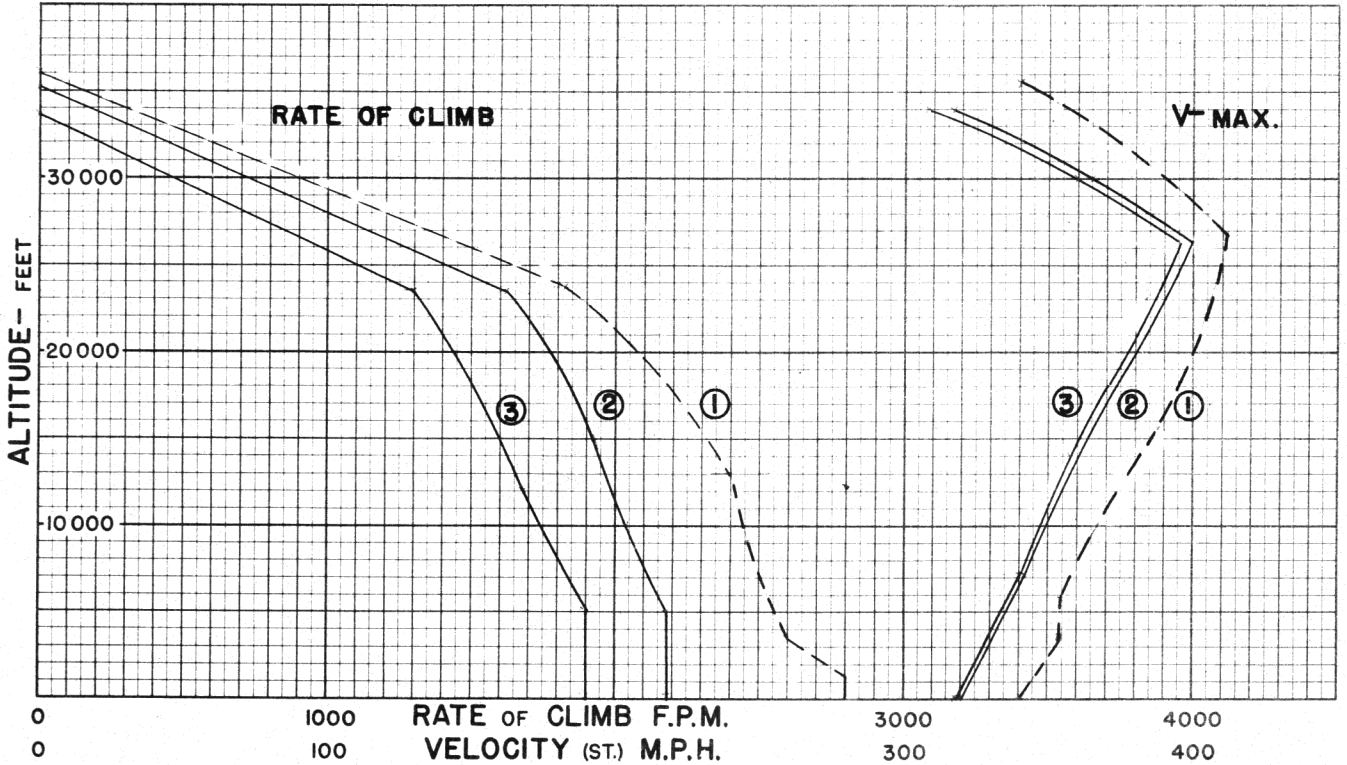

○ LOADING CONDITION COLUMN NUMBER



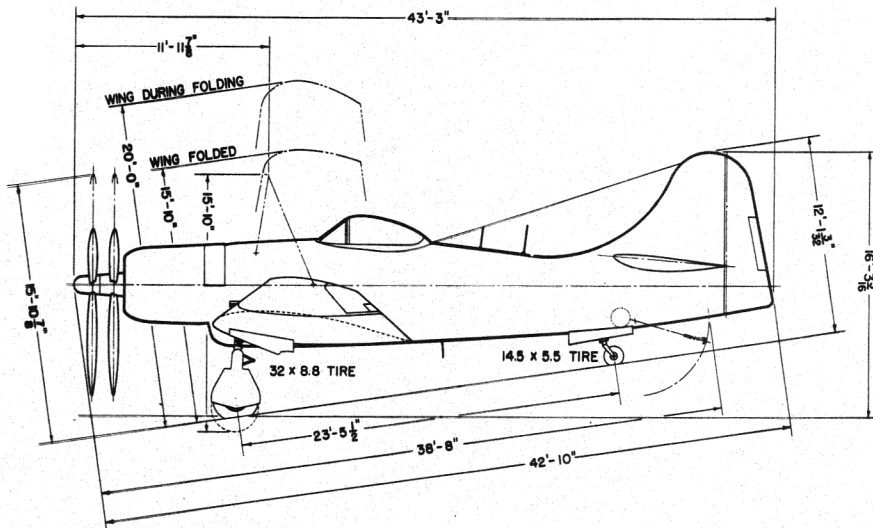
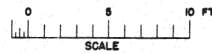
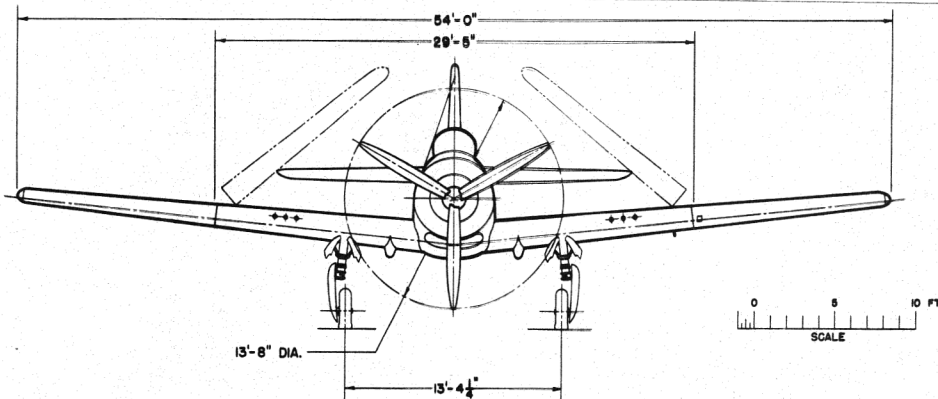
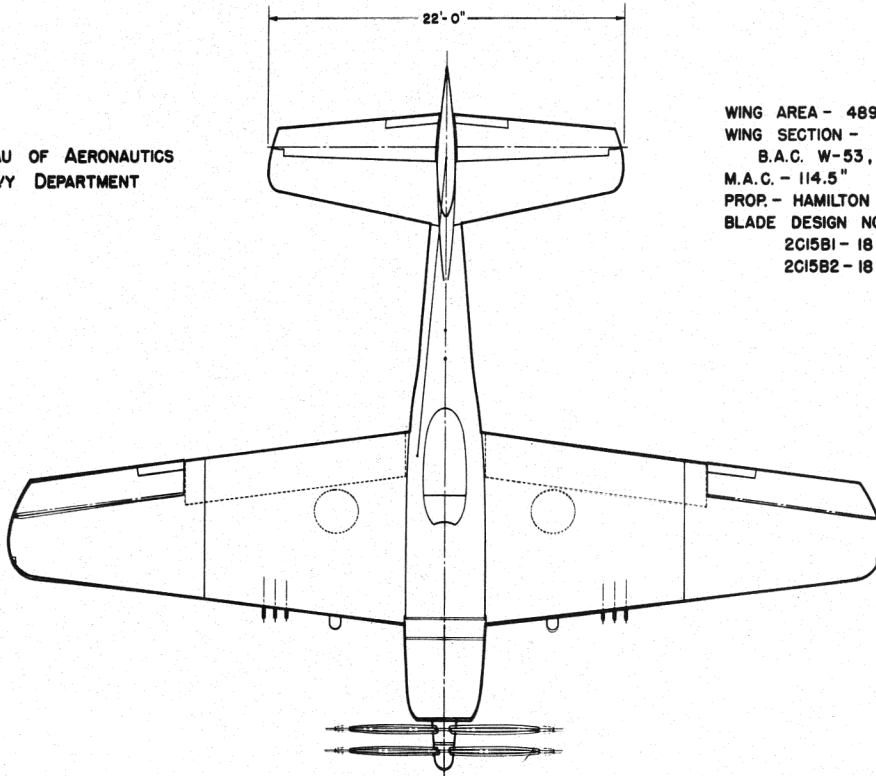

BUREAU OF AERONAUTICS
NAVY DEPARTMENT

WING AREA - 489 SQ. FT.
WING SECTION -
B.A.C. W-53, 15%
M.A.C. - 114.5"
PROP. - HAMILTON STD.
BLADE DESIGN NO. -
2C15B1 - 18 FW'D.
2C15B2 - 18 AFT



MODEL XF8B-1

BUREAU OF AERONAUTICS
NAVY DEPARTMENT

-  BULLET RESISTANT GLASS ARMOR PLATE
-  DEFLECTION PLATE
-  SELF-SEALING TANKS
-  NON SELF-SEALING TANKS

PROTECTION

- 1. PILOT FORWARD 12 LBS.
- 2. PILOT AFT 19 LBS.
- 3. SELF-SEALING CELLS 564 LBS.

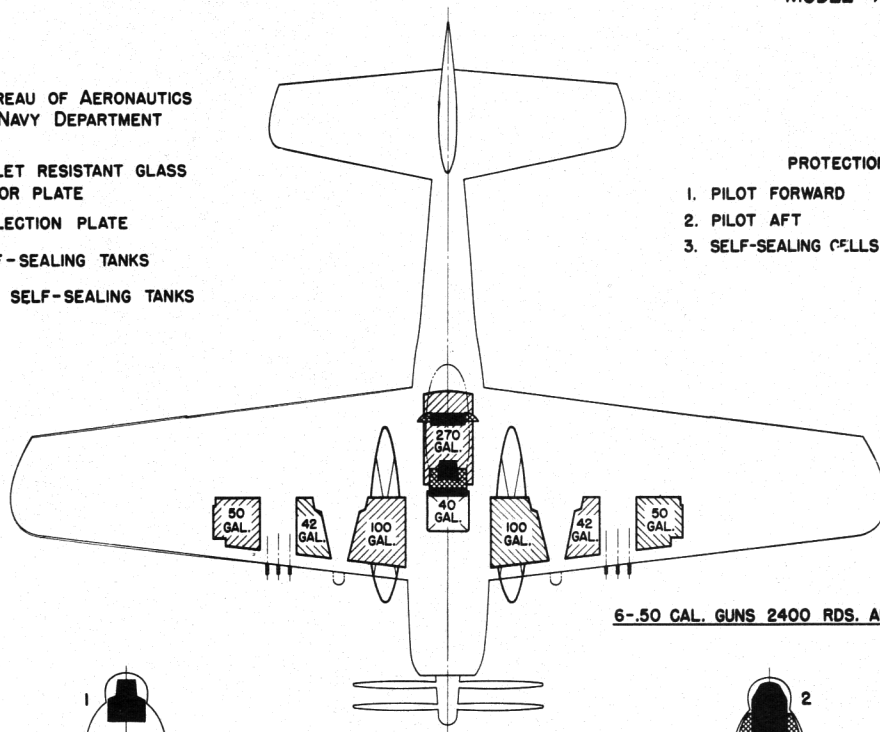

6-.50 CAL. GUNS 2400 RDS. AMMUNITION

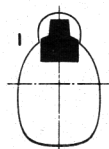

VIEW A TO B

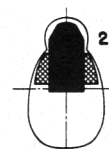

VIEW B

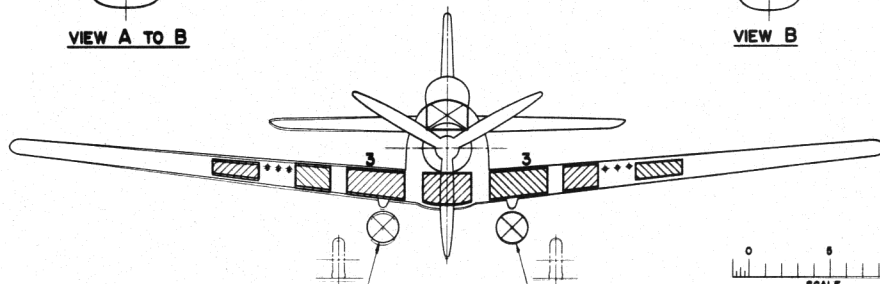

DROPPABLE TANKS
150 GAL. EACH

