

FMTV A1 R M1082 A1

2.5 ton Trailer

The Family of Medium Tactical Vehicles (FMTV) provides the U.S. Army's backbone for tactical unit mobility and logistics support throughout the battlefield. These vehicles are considered the most sophisticated off-road, multi-purpose military tactical vehicles in use, and are capable of operating worldwide on primary and secondary roads, as well as on trails and cross-country in weather extremes from -50°F (-46°C) to +120°F (49°C).

Product Numbers

LIN T96564

NSN 2320-01-449-1775

KEY FEATURES

Electronic Central Tire Inflation System (CTIS)

Interactive Electronic Technical Manuals (IETM)

Fully MANPRINT compliant

C-130 air transportable at GVW

U.S. Army proven ultra-reliability

Family of 16+ vehicles with 80% commonality

U.S. Army certified 22-year corrosion protection

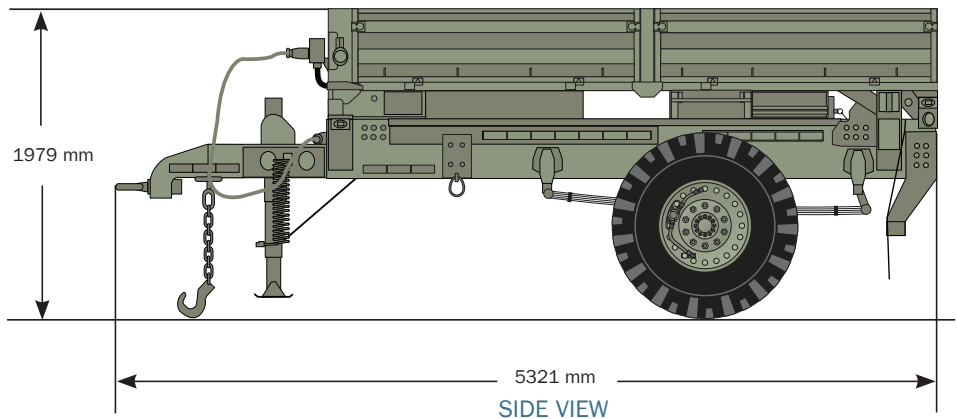

FMTV A1 R M1082 A1

2.5 ton Trailer

VEHICLE SPECIFICATIONS

Length:	
Overall	209.5 in (5,321 mm)
Cargo Bed (Inside)	149.1 in (3,785 mm)
Width:	
Overall	96 in (2,438 mm)
Cargo Bed (Inside)	91.5 in (2,324 mm)
Height:	
Overall	78 in (1,979 mm)
For Air Transport	78 in (1,979 mm)
Deck Height:	
Empty	59.5 in (1,512 mm)
Loaded	57 in (1,448 mm)
Ground Clearance:	
Empty	16.5 in (419 mm)
Loaded	13.5 in (343 mm)
Departure Angle:	25°
Vehicle Curb Weight (VCW):	
	7,306 lb (3,314 kg)
Gross Vehicle Weight (GVW):	
	12,306 lb (5,582 kg)
Tongue Weight:	
At VCW	882 lb (400 kg)
At GVW	1,292 lb (586 kg)
Payload:	5,000 lb (2,268 kg)
Maximum Grade:	30%
Side Slope:	30%
Fording:	30 in (762 mm)

EQUIPMENT SPECIFICATIONS

Axles:	ArvinMeritor Single
Brakes:	Air-Activated Internal Expansion with Anti-Lock Braking System (ABS)
Electrical System:	12/24 volt with Blackout
Tires:	Michelin 395/85R20XML All-Terrain
Suspension:	High Travel Single Axle Leaf Parabolic Spring with Anti-Sway Bar
Transportability/Deployability:	
Internally	Airdrop (LVAD) and Air Transportable by C-130, C-141, C-17, and C-5A at GVW
Externally	Transportable by CH-47 and CH-53 Helicopters with Integral Sling Bars
Cargo Bed:	
Construction	All Steel, E-COAT Rustproofing Dropside with Side Rail Storage
Ladder	Integral, Stowed
Optional	Bows and Tarp Kit

FOR MORE INFORMATION CONTACT:

BAE Systems
 5000 I-10 West
 Sealy, TX 77474 USA
 Telephone 281-856-0139
 Toll Free 866-390-1944
 Fax 979-885-7910
 Email sales.mhv@baesystems.com
 www.baesystems.com

This document gives only a general description of the product(s) or services and except where expressly provided otherwise shall not form part of any contract. From time to time, changes may be made in the products or the conditions of supply. BAE Systems reserves the right to change product specifications without prior notice.