

MHI
Copy 3

FM 30-102

WAR DEPARTMENT FIELD MANUAL

HANDBOOK ON AGGRESSOR MILITARY FORCES

DECLASSIFIED BY
AUTHORITY OF DOD DIR. 5200.1 R
BY RAKUS ON 10/20/03

DISSEMINATION OF RESTRICTED MATTER.—No person is entitled solely by virtue of his grade or position to knowledge or possession of classified matter. Such matter is entrusted only to those individuals whose official duties require such knowledge or possession. (See also AR 380-5.)

HANDBOOK
ON
AGGRESSOR
MILITARY FORCES



WAR DEPARTMENT

JUNE 1947

[REDACTED] DISSEMINATION OF RESTRICTED MATTER.—No person is entitled solely by virtue of his grade or position to knowledge or possession of classified matter. Such matter is entrusted only to those individuals whose official duties require such knowledge or possession. (See also AR 380-5.)

United States Government Printing Office

Washington: 1947

[REDACTED]

WAR DEPARTMENT
Washington 25, D. C., 30 June 1947

1. FM 30-102, Handbook on Aggressor Military Forces, is published for the information and guidance of all concerned.

2. *The country, peoples and forces described herein are entirely fictitious. Any resemblance to existing countries or forces is inadvertent and coincidental.*

[AG 300.7 (28 May 47)]

BY ORDER OF THE SECRETARY OF WAR:

DWIGHT D. EISENHOWER
Chief of Staff

OFFICIAL:

EDWARD F. WITSELL
Major General
The Adjutant General

DISTRIBUTION:

AAF (5); AGF (60); Gen & Sp Sv Sch (20), except Gen Sch (450), C&GS Coll (500), Inf Sch (50); USMA (10); A (25); CHQ (4); D (7); B (1); R (1).

For explanation of distribution formula, see TM 38-405.

CONTENTS

	<i>Paragraphs</i>	<i>Page</i>
CHAPTER 1. THE AGGRESSOR MILITARY SYSTEM.		
<i>Section I.</i> Historical outline	1- 6	1
<i>II.</i> The High Command	7- 9	5
<i>III.</i> Organization of the army for war	10-13	24
<i>IV.</i> Functions of the corps area	14-18	30
<i>V.</i> Conscription, replacement, and training	19-22	37
<i>VI.</i> The Peoples Militia	23-24	49
CHAPTER 2. ORGANIZATION OF THE FIELD FORCES.		
<i>Section I.</i> High command in the field	25	51
<i>II.</i> Organization of the field army	26-29	51
<i>III.</i> Army groups and armies	30-31	53
<i>IV.</i> Corps	32-33	56
<i>V.</i> Principles in unit organization and equipment	34	58
<i>VI.</i> Divisions	35-37	59
<i>VII.</i> Unit organizational charts	38	70
<i>VIII.</i> Combat troops	39-47	72
<i>IX.</i> Service troops	48-56	121
CHAPTER 3. OTHER MILITARY AND AUXILIARY ORGANIZATIONS.		
<i>Section I.</i> General	57	130
<i>II.</i> Ministry of Security and Propaganda	58	130
CHAPTER 4. TACTICS.		
<i>Section I.</i> Tactical doctrines	59-66	131
<i>II.</i> Basic tactical plans	67-69	132
<i>III.</i> Tactics of ground arms	70-73	133
<i>IV.</i> Special operations	74	134
<i>V.</i> Fortifications	75	134
CHAPTER 5. FORTIFICATIONS AND DEFENSES.		
<i>Section I.</i> Doctrine of fortifications	76-77	135
<i>II.</i> Characteristics of fortifications	78-82	136
CHAPTER 6. LOGISTICS.		
<i>Section I.</i> General	83	138
<i>II.</i> Supply and evacuation	84	138
<i>III.</i> System of supply within aggressor	85-86	139
<i>IV.</i> System of supply of the field army	87-89	141
<i>V.</i> Troop movements	90-91	144
CHAPTER 7. WEAPONS.		
<i>Section I.</i> General	92	145
<i>II.</i> Small arms	93	145
<i>III.</i> Mortars	94	145
<i>IV.</i> Artillery	95	146
<i>V.</i> Maximum effective ranges	96-99	146

	<i>Paragraphs</i>	<i>Page</i>
CHAPTER 8. EQUIPMENT.		
<i>Section I.</i> General	100	148
<i>II.</i> Armored vehicles	101	148
<i>III.</i> Vehicles	102	148
CHAPTER 9. AGGRESSOR AIR FORCE.		
<i>Section I.</i> General	103	149
<i>II.</i> Organization	104	149
<i>III.</i> Doctrine and tactics	105	149
<i>IV.</i> Aircraft	106	149
APPENDIX I. CONVENTIONAL SIGNS AND SYMBOLS.		
<i>Section I.</i> Introduction	1	152
<i>II.</i> Military symbols	2-14	152
II. GLOSSARY OF COMMON AGGRESSOR MILITARY TERMS		
<i>Section I.</i> English—Spanish, Italian, French, German	1- 2	172
<i>II.</i> Aggressor—English	3- 4	183

CHAPTER I

THE AGGRESSOR MILITARY SYSTEM

Section I. HISTORICAL OUTLINE

1. **GENERAL.** a. At the close of World War II in 1945 the chaotic conditions in Western Europe, which resulted from fundamental disagreements between the victorious allied nations and the failure of the United Nations Organization, gave rise to a new nation, Aggressor.

b. When the surrender of Germany was followed almost immediately by wholesale allied withdrawals, a small group of determined men, confirmed in their belief in the totalitarian nation-state, gathered in Spain, took over the control of the weakening government, and established the Aggressor Republic.

c. That this action was possible was due primarily to quarrels that broke out among the former allies, a disinclination on the part of any one nation to accept the responsibility for the direct physical action necessary to suppress this new group, and finally the clever use of propaganda and slogans which freely used the terms "democracy," "the people," and other similar terms.

d. As soon as the new government had firmly consolidated its position in Spain and Spanish Morocco, it began to infiltrate to the north and east. A fertile field for their well planned and executed propaganda was found in southern France, northern Italy, Bavaria, and the Tyrol, where United States occupational forces were rapidly being redeployed. A strong secession movement grew almost overnight in those areas which the weakened central governments of France and Italy and the ineffective provisional government of Bavaria were powerless to prevent. The natural revulsion of these peoples toward communism asserted itself and provided a strong psychological weapon for the organizers. All races and classes were appealed to.

e. After a brief but violent uprising in early 1946, aided and controlled from the Aggressor capital by means of a highly trained fifth column, these two areas were granted independence, promptly applied for union with Aggressor, and were admitted to the Republic.

f. Immediately upon the successful conclusion of this venture, Aggressor entered upon a well-balanced and carefully controlled period of intense development and organization of all resources and phases of national life. The immediate goal of national unity and relative self-sufficiency was quickly obtained. In contrast to its neighbors, Aggressor was

reasonably prosperous and its people happy and contented with the new government which started fulfilling its initial promises. Of course, one distinct advantage enjoyed by the new nation was that the bulk of its lands had escaped the destruction of war which had so severely impaired the national economy of other European nations. Aggressor was in a peculiar position in the world, as her able leaders had foreseen. Initially backed in secret by the western allied powers as a buffer against the Slavic nations and communism, Aggressor was even more secretly supported by the Comintern as an acceptable vehicle for the spread of communism throughout Catholic Europe and as a buffer to the wealthy western allies. Aggressor was engaged in a race against time. She must be a well established power when the dull and war-weary former allies realized her true ambition and organized to put her down. Her leaders believed that she must strike before that day. Her blow must be against the most powerful nation. While she was doing so the others must be kept placated. The nation to be struck must not be allowed to reach her offensive potential in order to lead the strike against the new nation.

g. Turning its attention from the devastated areas of Western Europe to the prosperous and unscathed lands of North America, Aggressor began plans in early 1946 for an invasion of the United States. Although the United States had emerged from the war as a strong military nation, its hasty and ill-advised demobilization together with widespread internal disturbances and general war weariness finally convinced the High Command that such a plan offered reasonable chance of success if aided by a well organized subversive organization and a skillful propaganda campaign.

h. Living up to its suggestive name, the newly founded confederation went into action. An expedition was hurriedly formed. To achieve strategic surprise, the California coast was selected as the invasion point. It was hoped that California, and perhaps Arizona and New Mexico, would be quickly overrun and then a negotiated peace obtained in which these areas would be ceded to Aggressor in return for an alliance between the two countries. The Rocky Mountains would provide a barrier to the movement of the bulk of the United States general reserves located in the Mississippi Valley and in the Atlantic coastal region.

i. The first military move in this plan was the seizure of the Panama Canal. In the guise of refugees and displaced persons from Europe, a large, well-armed and trained group settled around the Canal. Then, aided by agents and sympathizers in the Zone, the control of the Canal was quickly and easily secured. Perfectly timed with this seizure, the Expeditionary Force sailed through the Canal and up the west coast, landing as planned at several points on the California coast in November 1946. Simultaneously guided missile attacks were launched against the great rail and road centers of the Midwest and the industrial rectangle. Saboteurs blew in tunnels and smashed bridges that canalized communications through the Rockies.

j. The Expedition met with initial success, but the United States forces rallied rather more quickly than was expected and a grave and nearly fatal logistical error became apparent. The supply line was too long and exposed for the relatively small navy. Complete disaster was avoided only through the active assistance of American Quisling groups and sympathizers who had penetrated even into the United States Government.

k. Chiefly through the services of this group, a compromise peace was accepted. The Aggressor Forces were withdrawn from the Continental United States, but the seizure of certain Caribbean bases by Aggressor and the coups d'etat by Aggressor-influenced parties in neighboring Central American countries were recognized by the United States.

l. Since the signing of the peace treaty, Aggressor has redoubled its efforts to create a large, well-trained and equipped, air-transportable Armed Force. In this, they were aided by the rapid acquisition of thousands of long range United States aircraft abandoned in Europe upon the withdrawal of United States occupational forces. While in a sense the California Expedition was a failure, it gave indications of future possible success if conducted with more careful planning and in greater force. Propaganda aimed at the American Government and Armed Forces has flooded the country in various disguises. In all probability, it is only a question of time until Aggressor renews its attempt to subjugate the North American continent.

2. POPULATION. a. The newly acquired lands raised the population figure of the Republic to about 110,000,000. In addition, an active campaign was launched to attract immigrants and displaced persons from other European nations. Scientists, soldiers, and professional men of all types were particularly desired. Preferential treatment was accorded leaders in scientific, industrial, and military fields. Former Quisling groups of other nations took full advantage of this offer.

b. Strong efforts have been adopted to increase the population by raising the normal birth rate. The usual means of bounties, state education for certain children, and other conventional practices are in effect. The ultimate result, of course, will be the necessity of acquiring new lands to accommodate the fast-growing population.

3. LANGUAGE AND RELIGION. a. Spanish has been adopted as the official language; although it has not fully supplanted the local French, German, and Italian in certain areas, it is expected to do so in the course of another generation. In this matter and in religion, Aggressor has proved to be tactful, employing subtle means to achieve its ends.

b. While there is no state religion as such, complete religious freedom is enjoyed throughout the Republic. This policy has had the distinct advantage of not antagonizing or alienating any religious group. In fact, Aggressor agents have infiltrated the various religions and use them abroad to further their own national propaganda.

4. FORM OF GOVERNMENT. a. The government is completely totalitarian in form. Control is highly centralized at the top and tends somewhat toward bureaucracy. It enjoys the normal advantages attendant on totalitarianism, i. e., efficiency and quick decisive action with all branches of national life directed toward a common end (e. g., the quick mobilization for war in 1946).

b. Government functions are marked by impressive ritual and an air of mystery. This has had a strong appeal to many classes of people in the country.

c. The real power in government is in the hands of a small group of men. The total membership in this select group, having representatives from all professions, is for the most part unknown. International figures are present, among whom Martin Bormann, Tito Farruchi, Pilar Cordoba, and the great industrialist and financier, Kurt Fryssen, hold government portfolios. Strict party discipline is a fetish. Leadership is vested in the Supreme Council, familiarly termed the "Trinity" by followers and enemies alike. Bormann represents the Teutonic peoples, the popular Farruchi the Italians and French, and Cordoba the Spanish and Arab peoples. All of these men are popular, dynamic figures. Their authority appears to be equal.

5. INDUSTRY. Considerable emphasis has been placed upon development of national industry. With the factories of Bavaria and northern Italy as a nucleus, industry has been expanded and dispersed according to a well-conceived plan of national strategy. In this connection, the communication system has been revolutionized. The nation's war potential has been extensively developed. The manufacture of atomic weapons, though not definitely known, is believed to be taking place. Industry is closely coordinated with the needs of the armed forces.

6. ARMED FORCES. a. The armed forces have been rapidly expanded along sound lines. Disbanded troops of many nations flocked to the Aggressor Republic and formed the cadre of a large well-balanced professional fighting force. Conscription was inaugurated to build up a large trained reserve. Experienced military leadership was readily available and eager to accept employment; all were welcomed. The remnants of the Wehrmacht and the Junkers were again employed and rapidly regained their old self-esteem.

b. The training of all components is extremely thorough and rigorous. A very high standard of discipline is maintained; morale and esprit de corps are excellent, and the prestige of the armed forces is high.

c. The standing army is composed of two army groups, each numbering roughly 1,000,000 men. In addition, a third army group headquarters exists to train and control a replacement training army and a peoples militia integrated with the national police to be used as a final reserve in the event of invasion. The air force maintains two operational air armies

and in case of emergency assumes control of all civil aviation which is organized along military lines. One army group and an air army are stationed in Spain and Morocco, the other army group and air army in France and Italy.

d. The naval arm, while not large, is well developed. Weak in capital ships, the Aggressor Navy has emphasized submarines, aircraft carriers, and small, fast torpedo boats. Marine detachments perform local security duties, man naval antiaircraft defenses, and carry out shore patrol and other administrative functions. They are not organized for ground combat.

e. The nation's manpower, including women, has been carefully registered and graded by mental and physical profiles. In general, all combat arms receive about the same proportion of the various classifications. The infantry, however, receives particular attention and its recruits are carefully selected for physical stamina. Within the infantry, the fusiliers are a highly selected group, and represent the pick of the nation's manhood.

f. Every citizen is drafted for national service and directed to the work he can perform most efficiently. Those not accepted by the armed forces are carefully regulated as to type and place of work. Air raid protection and fire fighting groups are well organized. In addition, all personnel on civilian assignments can be called upon for service in a military force called up in case of invasion of the homeland.

Section II. THE HIGH COMMAND

7. INTRODUCTION. a. The basic principle under the Aggressor military system is unity of command. This principle is exemplified in the highest as well as the lowest echelons. Under this system the Army, Navy, and Air Force are regarded as branches of a single service, headed by the Armed Forces High Command. The Armed Forces High Command controls all matters of inter-service policy in both peace and war. It is responsible for all preparation for national defense in time of peace, and for the conduct of operations in time of war. The Armed Forces High Command comes under the direct supervision of the Secretariat for the Armed Forces, a cabinet ministry which represents the joint interest of the three branches with respect to other departments of the Government.

b. In effect, therefore, the Aggressor High Command is divided into four parts, as follows: Armed Forces High Command, Army High Command, Navy High Command, and Air Force High Command. The accompanying chart (fig. 1) shows the organization of the High Command and the principal subordination of the Army High Command.

c. The Armed Forces High Command appoints commanders for joint Task Forces in the field of operations where joint operations are to be undertaken. Under this system, it is not unusual for units of one branch

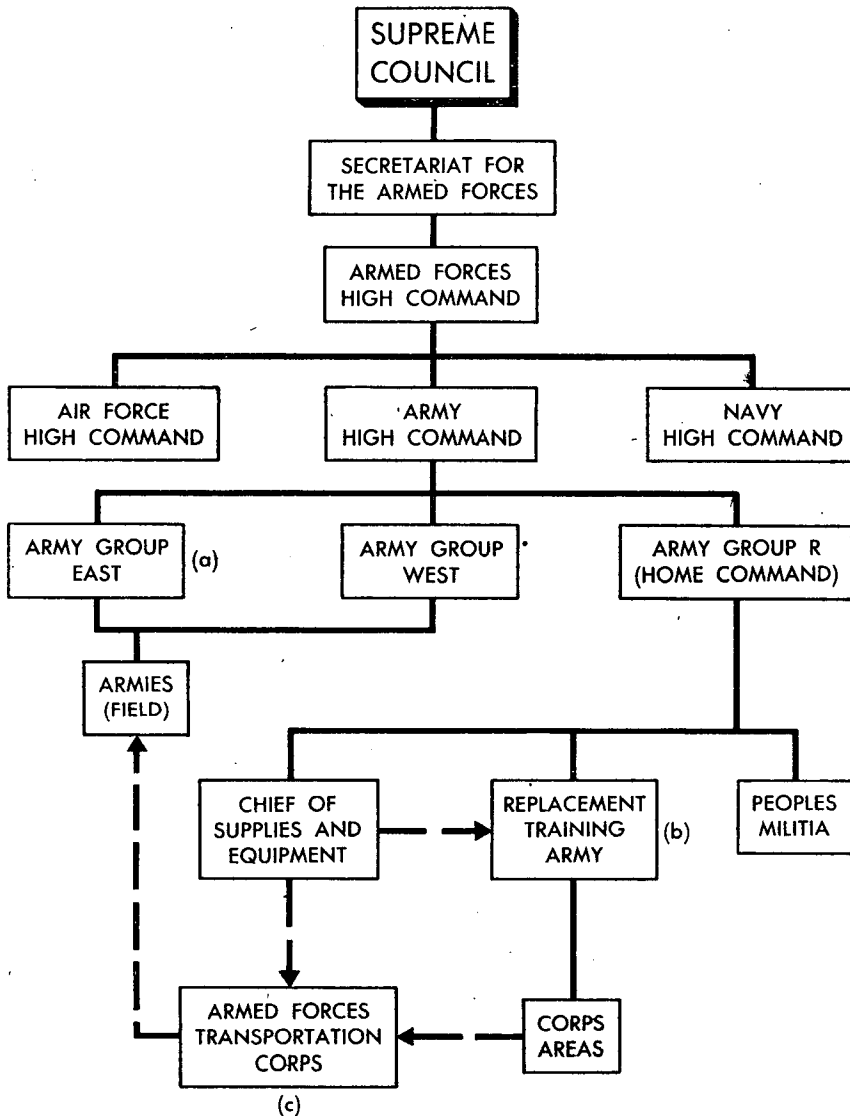

LEGEND:

———— Chain of Command - - - - - Flow of Supplies and Replacements

NOTES: (a) Army Group East and Army Group West constitute the Field Army

(b) The Replacement Training Army and the Peoples Militia constitute the Home Army

(c) Coordinates and exercises administrative control over all transportation—rail, motor, water, and air

Figure 1. Organization of the high command.

of the Armed Forces to come under the immediate command of another branch. All personnel may be transferred from one branch to another in the same or equivalent rank.

d. The Armed Forces High Command is the supreme command for all military activities and is responsible for the coordination of the active war effort by the three subordinate branches. The Army High Command is responsible for all purely Army matters, just as each of the other two High Commands is responsible for the application of general policies within its own sphere.

e. In wartime, each High Command has a forward echelon and a rear echelon. The forward echelon moves to a location appropriate to the theater of main operations, while the rear echelon remains in Madrid. The object of this division is to insure that all purely routine and administrative matters will be handled in the rear and not obtrude themselves into the actual conduct of operations by the forward headquarters.

f. The following description gives the nomenclature and function of the main subdivisions of the Armed Forces High Command and the Army High Command.

8. THE ARMED FORCES HIGH COMMAND. The chief of the Armed Forces High Command is known as the Commander in Chief of the Armed Forces, and has a Deputy Commander in Chief to assist him. Since the supreme power in the Aggressor state is vested in the Supreme Council (The Trinity), which administers the affairs of the nation through a system of cabinet ministries, the Commander in Chief of the Armed Forces acts as chief executive officer for the Armed Forces Secretariat in the administration of the Armed Forces and the application of the military policies and plans of the Supreme Council. The operational part of the Armed Forces High Command is the Armed Forces General Staff, which constitutes the main advisory body on strategy and planning. It is located at the field headquarters of the Armed Forces High Command, which is known as Supreme Headquarters. The other subdivisions of the Armed Forces High Command are with the rear echelon and deal with numerous administrative matters of joint interest to the three branches of the Armed Forces. The accompanying chart (fig. 2) shows the branches of the Armed Forces High Command and their subordination.

a. **Armed Forces General Staff.** This is a joint general staff containing officers from all three branches. It is responsible for over-all planning and strategy, and advises and assists the Commander in Chief of the Armed Forces in the planning and execution of military operations. It is controlled by the Chief of Armed Forces General Staff, assisted by a Deputy. It includes—

(1) *Operations Section (Section I; corresponds to our Plans and Operations Division, WDGS).* Joint planning staff for joint operations

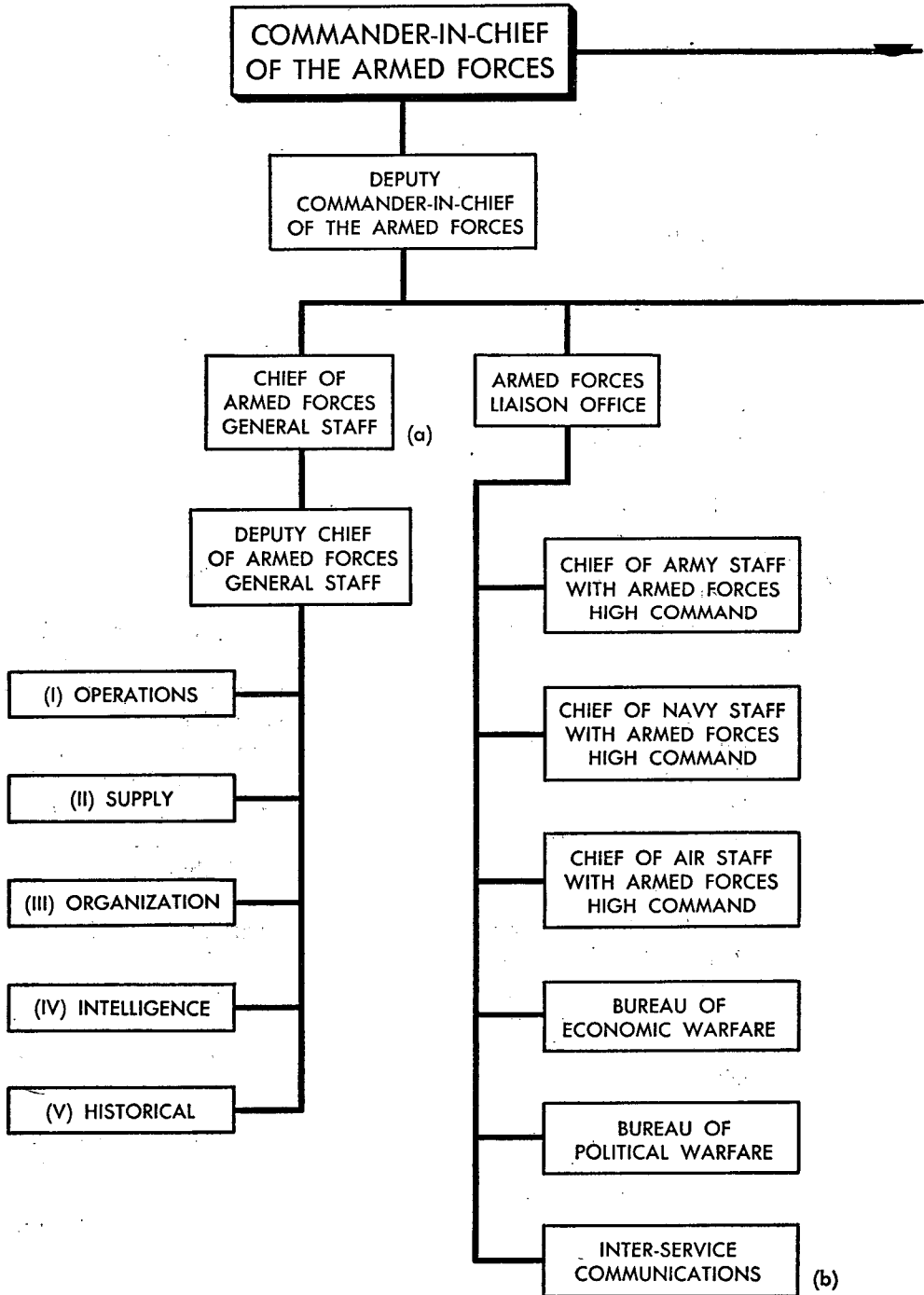

ARMED FORCES
POLITICAL GUIDANCE
STAFF

ARMED FORCES
CENTRAL OFFICE

GENERAL
ARMED FORCES
OFFICE

CONSCRIPTION AND
RECRUITING OFFICE

ARMED FORCES
PROPAGANDA OFFICE

CHIEF OF
TRANSPORTATION CORPS

PRISONERS OF WAR
OFFICE

ARMED FORCES
OPERATIONS
OFFICE

ARMED FORCES
PERSONNEL
OFFICE

ARMED FORCES
ADMINISTRATIVE
OFFICE

ARMED FORCES
ECONOMIC
OFFICE

NOTES: (a) Armed Forces General Staff is a Joint General Staff containing officers from Army, Navy, and Air Force

(b) Operates through Army Signal Corps

Figure 2. Armed forces high command.

sets up and controls special joint planning staffs for joint Task Force operations; submits to the Armed Forces Commander in Chief recommendations for commanders and operations officers for joint Task Forces; prepares general operational plans for Army, Navy, and Air Force; draws up general operational strategy for the three branches of service.

(2) *Supply Section (Section II; corresponds to our Service, Supply and Procurement Division, WDGS)*. Draws up general plans for coordinating the supply systems of the Army, Navy, and Air Force. Joint planning staff for planning and organizing supply and communication lines for joint operations sets up and controls special joint supply planning staffs for joint Task Force operations; submits to Armed Forces Commander in Chief recommendations for supply staffs for Joint Task Forces.

(3) *Organization Section (Section III; corresponds to Organization and Training Division, WDGS)*. Joint planning staff for joint operations. Selects the Army, Navy, and Air Force units to compose a joint Task Force after Operations Section (I) completes joint operations plans; coordinates organization of joint Task Forces regardless of location or branch of service. Draws up general plans for small, standard joint Task Forces for certain types of joint operations against small or lightly held coastal installations.

(4) *Intelligence Section (Section IV; corresponds to our Intelligence Division, WDGS)*. Responsible for strategic intelligence, i. e., political, economical, internal affairs, and over-all strategy of the enemy. Coordinates Army, Navy and Air Force intelligence sections. Preparatory to setting up joint operations planning staffs, this section must present to the chief of a special planning staff a complete intelligence picture of the theater of intended operations for the proposed joint Task Force. Submits to Armed Forces Commander in Chief recommendations for intelligence staffs for joint Task Forces. This section includes counter-intelligence.

(5) *Historical Section (Section V; corresponds to our Historical Division WD Special Staff)*. This section maintains duplicate files of the Historical Sections of the Army, Navy, and Air Force, and, in addition, records all military history which concerns the three branches of the Armed Forces as a whole.

b. Armed Forces Liaison Office. Central office for maintaining liaison between the three branches of the services, and coordinating economic and political warfare with the Armed Forces. It includes—

(1) *Chief of Army Staff with Armed Forces High Command.* Chief Liaison Officer of the Army at General Headquarters.

(2) *Chief of Navy Staff with Armed Forces High Command.* Chief Liaison Officer of the Navy at General Headquarters.

(3) *Chief of Air Staff with Armed Forces High Command.* Chief Liaison Officer of the Air Force at General Headquarters.

(4) *Bureau of Economic Warfare.* This is a small agency to represent the interests of the Armed Forces with other government agencies concerned with economic warfare.

(5) *Bureau of Political Warfare.* This is a small agency to represent the interests of the Armed Forces with other government agencies concerned with political warfare.

(6) *Inter-Service Communications.* This group maintains the trunk communications between the top commands and is the nerve center of the top command echelons. It has at least two signal regiments of the Army at its disposal to maintain a special network of land cables and radio channels linking the Armed Forces High Command, Army High Command, Navy High Command, Air Force High Command, and the principal subordinate headquarters. It contains a radio communications branch and a wire communications branch.

c. **Armed Forces Central Office.** This is a group of unrelated, but important administrative offices dealing with all branches of the Armed Forces. It includes—

(1) *Conscription and Recruiting Office.* This office has the function of controlling recruiting and conscription for the three branches of the Armed Forces.

(2) *Armed Forces Propaganda Office.* Headed by the Chief of the Propaganda Troops, this office is responsible for all types of military propaganda, except that which is fed to the troops by the Political Guidance Staffs of the various high commands. It includes sections for the administration of the propaganda troops, propaganda to the home front, military censorship, propaganda to foreign countries, and counter-propaganda.

(3) *Chief of Transportation Corps.* This officer is the administrative head of all rail and inland water transportation, and, in addition, maintains administrative control over all Army motor transportation, air transportation of the Air Force, and naval transports. He coordinates all transportation, military or civil, and works through branch offices, regional staffs, and staff officers at various command levels.

(4) *Prisoners of War Office.* This office is responsible for insuring the security of prisoner of war installations and the most effective employment of prisoner of war labor. It may issue orders to all agencies concerned with prisoners of war. It is the general administrative office for all matters relating to prisoners of war, including Aggressor personnel held by the enemy. The agency is divided into two branches: a General Branch which deals with treatment, exchange, and release of prisoners; administrative and punitive matters; and relations with the protective powers and with the International Red Cross; secondly, an Organization Branch, which deals with the employment and living conditions of prisoners of war in Aggressor hands.

d. **General Armed Forces Office.** This office is composed of inde-

pendent offices grouped together as the general executive agencies of the Armed Forces High Command. All orders from the Commander in Chief of the Armed Forces must go through this office which deals with all phases of the Armed Forces establishment. It includes—

(1) *Armed Forces Operations Office*. Acts as the operations executive office for the Commander in Chief of the Armed Forces. Assists the latter in studying and selecting plans received from the Operations Section of the Armed Forces General Staff; keeps in close touch with all operations in the field; transmits to the Army, Navy, and Air Force general plans in connection with over-all strategy. Directly supervises the operations of joint Task Forces in the field of operation.

(2) *Armed Forces Personnel Office (corresponds to our Personnel and Administration Division, WDGS)*. Acts as personnel executive office for the Commander in Chief of the Armed Forces. It is responsible for central organizational matters of the Armed Forces High Command, such as increasing or reducing the personnel of branches of the High Command; it handles all promotions within the High Command, and assists the Commander in Chief of the Armed Forces in selecting Commanders in Chief for the Army, Navy, Air Force, and joint Task Forces in the field. It assists in the selection of high-ranking officers to be detailed to the Armed Forces High Command; transmits all personnel directives and orders to the various high commands.

(3) *Armed Forces Economic Office*. This office is responsible for the carrying out of the plans of the Supply Section (II) of the Armed Forces General Staff. It provides for long-range military-economic planning, the economic exploitation of occupied areas, and represents the interests of the Armed Forces with other government departments concerned with production, raw materials, labor, agriculture, and foreign trade. Coordinates the supply procurement activities of the three branches of service.

(4) *Armed Forces Administration Office*. Responsible for the administration of all Armed Forces High Command agencies and personnel; this administration includes mainly the procurement of rations, billets, pay, and clothing for personnel at Armed Forces High Command. Prepares general administrative rules for the three services; supervises and controls through the various High Command Administrative Offices the several administrative services, such as Adjutant General's Department, Judge Advocate General's Department, and the Inspector General's Department. Responsible for setting up accounting and finance procedures through the Armed Forces; handles the Armed Forces Budget and other fiscal matters, dealing with the Finance Ministry through the Armed Forces Secretariat.

e. *Armed Forces Political Guidance Staff*. This agency is to insure uniform political indoctrination in the Armed Forces, in cooperation with the Party headquarters. It includes—

(1) *Interior Group*. This group maintains liaison between the Armed Forces and civilian agencies. It contains a domestic security branch and an ideological branch.

(2) *Party Liaison*. This group maintains liaison with the Party headquarters, and controls such matters as collections for charitable or Party purposes within the Armed Forces.

9. THE ARMY HIGH COMMAND. The Chief of the Army High Command is the Commander in Chief of the Army, and acts as a chief executive officer of the Commander in Chief of the Armed Forces in carrying out military policies in matters pertaining to the Army alone. The accompanying chart (fig. 3) shows the branches of the Army High Command and their principal subordination. Their functions are discussed in the following paragraphs.

a. Army General Staff. This organization, which is a functional part of the Army High Command, must not be confused with the General Staff Corps. The latter is a category of specially selected and carefully trained officers who fill almost all the important command as well as staff positions throughout the Army. The Army General Staff, on the other hand, occupies a position analogous to that of the War Department General Staff; it is the main advisory body to the Commander in Chief on operations, intelligence, organization, supply, and general matters of Army policy. Both the Army General Staff and the General Staff Corps are headed by the Chief of the Army General Staff, who is assisted by a Deputy Chief of Staff. In time of war, the Army General Staff is stationed at field headquarters, leaving only a small rear echelon in Madrid. The Army General Staff basically consists of five main sections which cover all the proper staff and planning functions. Each of these sections is under the control of a chief, known as Chief I-V. In addition, a number of high-ranking officers are appointed by the chiefs of branches as chief advisers on the employment of the various arms and services in the field and on certain other technical matters; these officers are a part of the Army General Staff for the duration of their appointments. The groupings of the Army General Staff are—

(1) *Operations and Training Section (Section I; similar to our G-3, AGF)*. This section, concerned with operations and training, develops and disseminates basic tactical rules and methods of conducting warfare; it supervises field training in the Theater of Operations, and works through the Chief of Training in the Replacement Training Army in the Zone of the Interior, to train replacements for the field army. All training by tactical units, even in the Zone of the Interior, is under the direct supervision of this section.

(2) *Supply and Administration Section (Section II; similar to our G-4, AGF)*. This section is in charge of the whole supply and administrative structure of the Field Army.

(a) It is divided into three main groups, each headed by a General

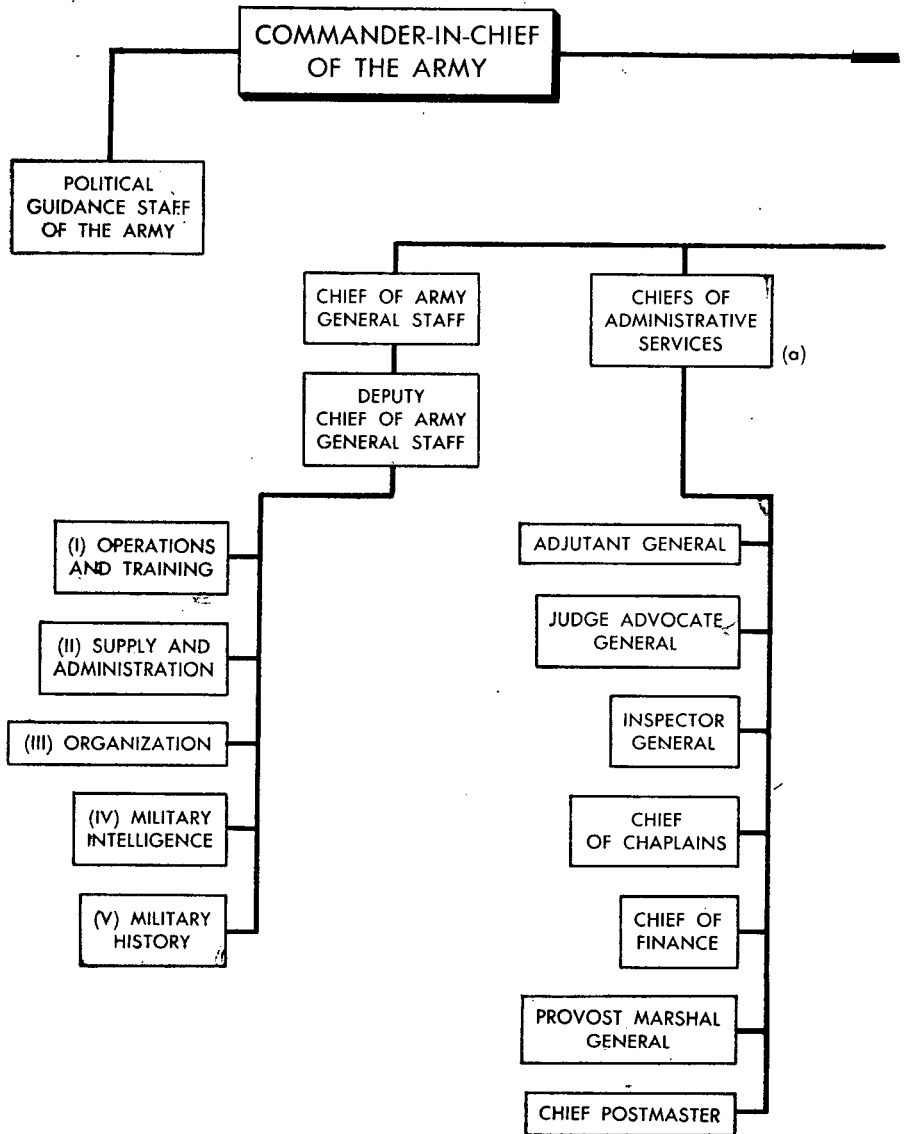

NOTES: (a) Chiefs of Branches and Services constitute the Special Staff

(b) Chiefs of Propaganda Corps operates under direction of Armed Forces Propaganda Office

(c) Chief Army Transportation Officer acts as Liaison Officer between Army High Command and Armed Forces Chief of Transportation Corps

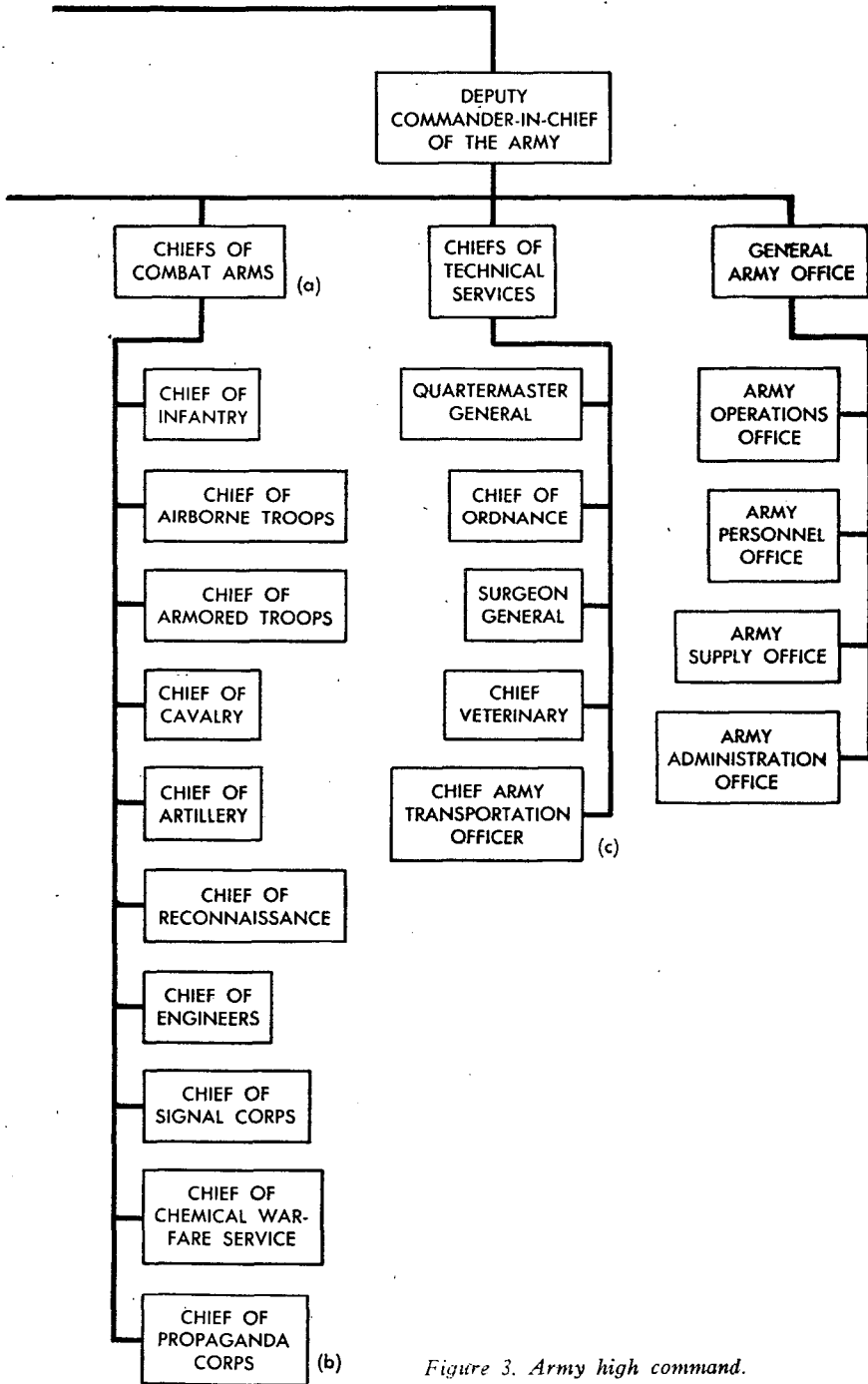

Figure 3. Army high command.

Staff Corps officer, and it is these three groups that may be regarded as constituting the G-4 division of the Army General Staff. They are as follows:

1. General planning and organization of supply in the field, establishment of communication lines and rear boundaries of the Theater of Operations, transport questions in conjunction with the Chief Army Transportation Officer, and control of those service troops not sub-allotted to army groups and armies.
2. Civil affairs policies in the communications zone, especially the exploitation of the country for military purposes; evacuation, booty, and prisoners of war.
3. Action on supply requisitions from army groups and armies for ordnance, fuel (Quartermaster Corps issue), and engineer equipment. These requisitions are adjusted in accordance with over-all plans and policies and are then forwarded to the authorities in the Zone of the Interior.

(b) In addition to the above three General Staff groups, there are a number of special staff officers who act as chiefs of the various services for the Field Army; they are appointed by the chiefs of branches concerned, and remain on the staff of the Chief Supply and Administrative Officer (Chief II) for the duration of their appointment. These officers bear the same relationship to the General Staff as the representatives of the chiefs of arms, except that they come under the Chief Supply and Administrative Officer instead of being attached directly to the Chief of Army General Staff. These special staff officers control all service troops in the field, heading what constitutes a service force comparable to our Army Service Forces. This special staff organization is given below:

1. *Adjutant General*. Chief of Adjutant General's Department in the field; maintains all records for the Field Army; supervises Personnel Officer, who prepares requisitions for replacements for the Field Army. Also responsible for personnel and security matters within the staff of Chief Supply and Administration Office.
2. *Judge Advocate General*. Chief of Judge Advocate General's Department in the field; responsible for questions of military law and jurisprudence.
3. *Inspector General*. Chief of Inspector General's Department in the field; responsible for all matters concerning the efficiency of the operations, training, supply, and administration of the Field Army.
4. *Chaplain*. Chief Chaplain for the Field Army, supervising work of all chaplains in the field.
5. *Motor Officer*. Representative of the Chief Motor Transport Officer of the Ordnance Department. Controls the motor

maintenance troops (Ordnance personnel) in the Field Army, and is responsible for general questions of availability and utilization of motor transport.

6. *Chief Administrative Officer.* Representative of the Quartermaster General's Office in the field. Responsible for clothing, personal equipment, rations, and billeting. Advises Army Administrative Office on any fiscal matters or other general administrative matters not under the control of the Quartermaster General; supervises the headquarters detachments finance offices.
7. *Finance Officer.* Chief of the Finance Department in the field. Supervises and controls all finance offices, except Corps, Army, and Army Group headquarters detachments finance offices (see 6 above).
8. *Surgeon.* Controls all medical matters and medical personnel throughout the Field Army, subject to the direction of the Surgeon General.
9. *Veterinary.* Controls all veterinary matters and veterinary personnel in the Field Army, subject to the direction of Chief Veterinary.
10. *Postmaster.* Responsible for all questions relating to Postal Service in the Field Army.
11. *Chief of Supply Troops.* Representative of the Transportation Section of the Quartermaster General's Department. Controls all General Headquarters supply troops, working in cooperation with the Supply Officer (II) on questions of their employment.
12. *Chief Military Police Officer.* Responsible for all matters concerning the organizations and employment of the military police in the Field Army.
13. *Civil Commissioner.* Responsible for non-military matters in the civil administration of occupied areas in the Theater of Operations, including relations with the civil authorities and the discipline of the population; cooperates with group (a) 2 above of general staff supply and Judge Advocate General, 2 above.

(3) *Organization Section (Section III).* This section is responsible for laying down rules relating to various aspects of organization in the field. Works in conjunction with the chiefs of arms and services and the Chief of Training of the Replacement Training Army in the preparation of new tables of organization or changes in existing tables. Operates through the Army Administration Office in the issuance of these particulars to the organizations concerned. This section is also responsible for setting up the special organizations of army and theater task forces. Recommends and

makes suggestions to the Chief of the Army General Staff concerning any reorganization of the Army High Command set-up.

(4) *Military Intelligence Section (Section IV; similar to our G-2, AGF)*. This section deals with both intelligence and counterintelligence. It is responsible for the collection and dissemination of all intelligence dealing primarily with the military forces and military potential of other countries. It maintains espionage and counterespionage nets. It assists the other general staff sections in dealing with intelligence problems in the planning phases of future operations. It also concerns itself with military geography, topography, and climatic conditions, in preparing terrain intelligence. This section is also responsible for furnishing trained intelligence personnel for staffs of all echelons down to and including divisions.

(5) *Military History (corresponds to our Ground Historical Section, AGF)*. Deals with military history and the science of military tactics. Maintains libraries dealing with all phases of military operations and planning. Contains a scientific research and development section to assist the chiefs of branches concerned in the study and development of new weapons.

b. Chiefs of Branches. In peacetime, the offices of the chiefs of branches are located at Armed Forces High Command headquarters, but in wartime these offices remain behind with the rear echelon to supervise the training of their troops in the Replacement Training Army, or to carry on their administrative or supply duties in the Zone of the Interior. Representatives of the various arms and services are, however, appointed by the chiefs of branches to accompany field headquarters. There are, therefore, at the disposal of the Commander in Chief of the Army and the Chief of the Army General Staff in wartime a group of general officers representing the various combat arms who serve as the principal advisers on the organization, training, equipment, and tactical employment of their respective arms in the field. They usually have no actual command authority, but may issue instructions and suggestions to the troops based on the evaluation of experience in the field. For the publication of technical manuals and the like, they collaborate with the Chiefs of their branches with the rear echelon. They may also recommend changes in the organization and equipment of the troops to the Organization Section (III) of the Army General Staff for forwarding to the chiefs of branches concerned. The chiefs of those branches of the Aggressor Army which are classed as service troops are likewise attached to the General Staff in wartime, but as has been shown above, are placed under the Chief Supply and Administration Officer (II). The chiefs of branches as a group constitute what is known as the Special Staff for the Commander in Chief of the Army and the Chief of the Army General Staff. For administrative purposes, they are grouped into three main divisions as described below.

(1) *Chiefs of Administrative Services.* These are the service branches which perform or supervise purely administrative functions throughout

the army, and are not concerned with either technical matters or furnishing supplies to the troops.

(a) *Adjutant General*. Controls the Adjutant General's Department throughout the army. Responsible for keeping all personnel and other records; furnishes clerical and administrative advice and assistance to all other branches of service. Acts as a secretary for the commanding officer at all echelons; also responsible for security matters within the staff offices.

(b) *Judge Advocate General*. Controls the Judge Advocate General's Department throughout the army. Chief of all army legal administration matters; advises the Commander in Chief on all matters of jurisprudence and military justice.

(c) *Inspector General*. Controls the Inspector General's Department throughout the army. Responsible for all matters pertaining to the efficiency or economy of the military establishment. Institutes such special inspections or investigations as the Commander in Chief may direct; coordinates and supervises all work of inspectors for the various branches who keep a close check on training, functioning of supply system, and general administrative matters which affect the efficiency of the army as a whole.

(d) *Chief of Chaplains*. Controls all chaplains throughout the army. Insures that complete religious freedom is maintained throughout the entire military establishment. Advises the Commander in Chief and all other staff members on religious and moral matters. Responsible for maintaining a high spiritual morale in conjunction with the political indoctrination officers throughout the field army.

(e) *Chief of Finance*. Chief of Finance Department. Advises the Commander in Chief and staff on all fiscal matters; supervises the work of all army finance offices. Maintains all records of finance, payments to troops, and all disbursements of any kind throughout the entire military establishment. Assists the Army Administration Office in the preparation of the budget, and acts as adviser to this office on all other fiscal matters which may be of concern or interest to the Secretariat for the Armed Forces.

(f) *Provost Marshal General*. Chief of Military Police. Responsible for maintaining traffic discipline throughout the supply system both in the Zone of the Interior and in the Theater of Operations; also responsible for the guarding of vital military installations in the field, and escorting prisoners of war to the rear areas. Maintains prisoner of war installations under the direction and supervision of the Armed Forces Prisoner of War Office. Assists other military guards and special security details in maintaining discipline throughout the army.

(g) *Chief Postmaster*. Chief of Army Postal Service. Maintains postal system throughout the army, working in conjunction with civil postal service. Acts as adviser on all matters concerning the operation of the field post offices.

(2) *Chiefs of Combat Arms.* These are the chiefs of the troops who are actually concerned in combat operations with the enemy.

(a) *Chief of Infantry.* Responsible for the organization and training of all infantry units in the infantry divisions (standard, light, or motorized), the fusilier divisions (elite motorized troops), and GHQ and Corps special infantry units; working in conjunction with the Chief of Airborne Troops, he is responsible for the organization and training of the parachute infantry troops; and in conjunction with the Chief of Armored Troops, for the armored infantry units of the armored divisions, the mechanized divisions, and the cavalry divisions. Acts as adviser on the tactical employment of the three types of infantry divisions, the fusilier divisions, and the GHQ and Corps special infantry units in the field. Assists the Chief of Airborne Troops in problems concerning the employment of the parachute infantry troops; assists the Chief of Armored Troops in problems concerning the employment of the armored infantry units. Assists the General Staff Organization Section (III) in drawing up tables of organization and equipment in all matters concerning infantry troops; in conjunction with the chiefs of other branches concerned, to work out the tables of organization and equipment for the infantry and fusilier divisions.

(b) *Chief of Airborne Troops.* Responsible for all tactical questions on the employment of airborne troops. In conjunction with the chiefs of branches concerned, to work out the tables of organization and equipment for the airborne divisions, cooperating with the Organization Section (III). Responsible for the tactical training of the airborne divisions as a whole, and working in conjunction with the chiefs of branches concerned, for the training and tactical employment of the components of the airborne divisions.

(c) *Chief of Armored Troops.* Responsible for the organization and training of all armored units in the armored, mechanized, and cavalry divisions, and the GHQ and Corps special armored units. Working in conjunction with the chiefs of other branches concerned, to form tables of organization and equipment for all units of the armored divisions and the mechanized divisions, and in conjunction with the Chief of Cavalry, for the armored units of the cavalry divisions, cooperating with chiefs of other branches concerned. Responsible for tactical employment of the armored divisions, mechanized divisions, and the GHQ and Corps special armored units, and assists the Chief of Cavalry in tactical questions concerning the armored units of the cavalry divisions. Assists the Organization Section (III) in drawing up tables of organization and equipment in all matters concerning the armored units of the various divisions, and in conjunction with the chiefs of other branches concerned, the complete organization of the armored divisions and the mechanized divisions.

(d) *Chief of Cavalry.* Responsible for the organization and training of the cavalry units of the cavalry divisions. In conjunction with the chiefs

of other branches concerned, to work out tables of organization and equipment for the other elements of the cavalry divisions. Responsible for all questions pertaining to the tactical employment of the cavalry division as a whole, and, working in conjunction with the chiefs of other branches concerned, for the training and tactical employment of the other components of the cavalry divisions.

(e) *Chief of Artillery.* Responsible for the training and organization of all the artillery units of the army. Responsible for all questions concerning the employment of the artillery divisions as a whole, and assists in matters pertaining to the tactical use of artillery in the infantry, fusilier, airborne, armored, mechanized, and cavalry divisions. Assists the Organization Section (III) in working out tables of organization and equipment for all artillery units in the artillery divisions, the GHQ and Corps special artillery units, and in conjunction with the chiefs of other branches concerned, for the other components of the artillery divisions and for the artillery units in all the other types of divisions.

(f) *Chief of Reconnaissance.* Chief of all reconnaissance troops, regardless of type of division. In conjunction with the chiefs of all other branches concerned, to assist the Organization Section (III) in working out tables of organization and equipment for the reconnaissance elements of the various types of divisions. Responsible for questions concerning tactical employment of the reconnaissance troops. Directly supervises the training of the reconnaissance troops, and assists the Chiefs of Infantry, Airborne Troops, Armored Troops, and Cavalry, in the tactical training of the divisions under their control.

(g) *Chief of Engineers.* Advises on all matters pertaining to operations of the Engineers. Responsible for the training and organization of all Engineer troops. Responsible for questions pertaining to the employment of GHQ and Corps special engineer units, and assists the Chiefs of Infantry, Airborne Troops, Armored Troops, and Cavalry, in the employment of engineer units in the divisions under their control. In conjunction with the chiefs of branches concerned, works out tables of organization and equipment for all types of engineer units in the various types of divisions. Acts as special adviser on large civilian projects which may be of interest or use to the Armed Forces; acts as liaison officer for the Armed Forces in dealing with other cabinet ministries on questions of general engineering in Aggressor.

(h) *Chief of Signal Corps.* Responsible for all questions concerning employment of signal troops. Working in conjunction with the chiefs of branches concerned, to set up tables of organization and equipment for all types of divisions, higher headquarters units, and Army High Command and Armed Forces High Command special units. To control and supervise, working in conjunction with the Chief of Supplies and Equipment under the direction of the Army Supply Office, the development, procurement, storage, issue, and repair, of signal, meteorological and crypto-

graphic equipment and supplies; and to advise on all questions pertaining to any of these phases. To work with civilian communications authorities in producing a unified network of communications for wartime High Command control; to cooperate with civilian research organizations in matters pertaining to photographic, electrical, radio, or other similar technical research.

(i) *Chief of Chemical Warfare Service.* Chief of all chemical troops. Responsible for the training, organization, and equipment of all chemical units. Chief adviser to Army High Command on the use and employment of chemical weapons and troops in the field. Issues all directives on chemical warfare training for use of higher headquarters, and for use in training troops of all types of divisions in the field. Maintains close liaison with civilian research and development agencies.

(j) *Chief of Propaganda Corps.* Works under the direction of the Armed Forces Chief of Propaganda Troops. Responsible for all questions pertaining to the use of propaganda troops in the field, their duties, organization, and training. Acts as liaison officer between Army High Command and the Chief of Propaganda Troops. Directs personally all operations of the Army propaganda troops.

(3) *Chiefs of Technical Services.* These are services which supply or service the army, and which require a detailed, specialized, and technical knowledge in order to carry out their missions. All of them are classed as service troops, and work under the supervision of the Chief Supply and Administration Officer (II) in the field, and under the Chief of Supplies and Equipment in the Zone of the Interior, where they supervise the procurement, storage, and issue of their particular supplies and equipment.

(a) *Quartermaster General.* Chief of the Quartermaster General's Department, which has two sections, the Administration Section and the Supply Section, each headed by a chief. The Administration Section is responsible for the procurement, storage, and issue of rations, clothing, and personal equipment, and for housing or billeting the army, and all matters pertaining to them. The Supply Section is responsible for the actual transportation of supplies to the field army. It contacts the Chief Army Transportation Officer for arrangements with the Armed Forces Transportation Corps to move Quartermaster items to the field of operations. It operates and supervises Motor Transport units and various other supply column types of transportation units to move supplies of all types to the front, and provides the fuel and other automotive products necessary for carrying out transportation missions in the field army. The Quartermaster General acts as liaison officer for the Army High Command in dealing with other interested cabinet ministries in connection with industry, agriculture, and other matters pertaining to the operations of the Quartermaster Corps.

(b) *Chief of Ordnance.* Exercises general control over all ordnance troops in the field. Acts as adviser on all matters pertaining to ordnance

operations in the field of operations or in the Zone of the Interior. This department operates under two sections, the Ordnance Section proper which deals with munitions and matériel, and the Motor Transport Section which deals only with automotive equipment and its maintenance. The Chief of the Motor Transport Section is chief of all the automotive maintenance and repair troops in the field, and is the general adviser on all matters pertaining to motor transport. The Chief of the Ordnance Section is responsible for the design, testing, development, and acceptance of all other ordnance equipment, and operates mainly in the Zone of the Interior, where he supervises the procurement, storage, and issue (under the direction of the Chief of Supplies and Equipment) of all ordnance matériel, supplies, and equipment. Maintains close contact with civilian organizations and munitions factories in the research and development of new weapons.

(c) *Surgeon General*. Chief officer of the Medical Corps. Responsible for training, organization, and questions pertaining to the employment of medical troops in the field. Issues all instructions for the use of medical troops in the field, and all general matters pertaining to the health of the army. Maintains close liaison with civilian and hospital medical authorities and acts as liaison officer for the Army High Command in all matters pertaining to the cabinet ministry concerned with the health and well-being of the nation.

(d) *Chief Veterinary*. Responsible for all veterinary matters in the army. Controls and supervises the field operations of the veterinary service throughout the army. Responsible for the organization and training of the veterinary troops. Cooperates with the Chief of Cavalry in problems of servicing the animals of the cavalry divisions.

(e) *Chief Army Transportation Officer*. Works under the direction of the Armed Forces Chief of Transportation Corps. Acts as liaison officer between Army High Command and Chief of Transportation Corps. Coordinates all army transportation from the Zone of the Interior to the Theater of Operations, where the Quartermaster Corps takes over the motor transportation division. Maintains staff officers at higher headquarters in the field to coordinate rail, water, and air transportation in rear areas of the Theater of Operations. Assists the Chief of Supplies and Equipment in arranging for transportation in moving supplies from corps area supply depots and parks to the front.

c. General Army Office. This office consists of a group of executive offices which act as the agencies in administering the orders of the Commander in Chief of the Army. All orders and directives must pass through these offices for distribution to the forces in the field.

(1) *Army Operations Office*. Assists the Commander in Chief in controlling operations of the field army. Helps the Commander in Chief in the selection and operation of the plans submitted by the Operations and Training Section (I) of the General Staff. Maintains liaison with

Armed Forces Operations Office for general over-all strategy of the Armed Forces, and the particular missions assigned to the Army.

(2) *Army Personnel Office (Corresponds to our G-1, AGF)*. It is responsible for all appointments, transfers, promotions, and other matters concerning all types of officers in the Aggressor Army, working in cooperation with the chiefs of branches concerned. Selects, subject to the approval of the Army Commander in Chief, all officers for the General Staff and the General Staff Corps, and all commanders of divisions, corps, armies, and army groups. Selects the officers to be sent to the Armed Forces High Command in accordance with requisitions from the Armed Forces Personnel Office. Keeps the Army High Command informed at all times on the status of the personnel situation throughout the army. Aids in selecting the chiefs of the several branches of service.

(3) *Army Supply Office*. The agency in carrying out the plans of the Supply and Administration Section (II) of the General Staff. Operates through the Armed Forces Transportation Corps and the Chief of Supplies and Equipment, which controls all army supply agencies in the field. Maintains close liaison with the Armed Forces Supply Office for matters of general interest to the supply services.

(4) *Army Administration Office*. The agency in carrying out administrative matters of general interest to the whole army. Prepares the Army budget in cooperation with the Chief of Army Finance. Acts as liaison officer for the army in matters concerning the various cabinet ministries. Responsible for the administration of the entire Army High Command structure, and submits plans and reorganization changes to the Commander in Chief concerning the personnel of the branches or the branches themselves of the Army High Command. Coordinates all the instructions of the Administrative Services to the troops. Maintains close liaison with the Armed Forces Administrative Office.

Section III. ORGANIZATION OF THE ARMY FOR WAR

10. GENERAL ORGANIZATION. a. The Aggressor Army is permanently split from top to bottom into two mutually exclusive parts, which are designed to perform two distinct functions. One part is concerned only with military operations and the tactical training therefor, and is known as the Field Army. Army Group West and Army Group East constitute this Field Army. The other part was created for the sole purpose of servicing and maintaining the Field Army. This second part is under the command of Army Group R, known as the Home Command. It has three main responsibilities—

(1) The conscription, induction, training, and replacement of personnel. The Replacement Training Army was created for this purpose, and operates through corps areas which were set up to facilitate the administration of the replacement training system.

(2) The procurement, storage, and issue of supplies and equipment. The office of Chief of Supplies and Equipment was created to supervise and coordinate all supply agencies and activities.

(3) The organization, training, and operational control of a Home Army to be used as a final reserve in the event of invasion. This Home Army consists of the Replacement Training Army and a Peoples Militia integrated with the national police.

b. In case of war, the operational parts of the High Command, including the Commander in Chief and the bulk of the General Staff, establish a field headquarters away from Madrid to control the Field Army. The rest of the High Command reverts to the control of Army Group R (*The Home Command*), which is responsible for maintaining the Field Army by the dispatch of replacements, the formation of new units, and the supply of matériel, as well as continuing the normal military functions at home.

11. TERRITORIAL BASIS. a. In accordance with the plans outlined above, the whole of the Aggressor homeland was to be divided up into corps areas. It was originally intended to follow the corps area pattern of the old German corps area (*Wehrkreise*) system, under which the commander of the corps area was simultaneously the commanding general of the corps which he was destined to lead into the field on the outbreak of war. It soon became apparent, however, that this was an unwieldy system, due to the necessity of constantly revising the corps area boundaries as the number of corps in the army increased or diminished. Accordingly, 14 corps areas were selected as a permanent home territorial basis, and their boundaries readjusted and enlarged so that they covered the entire Aggressor homeland. Their number designations, however, given originally in Roman numerals to correspond to the corps it would send into the field, were left unchanged; this accounts for the lack of consecutive numbering of the corps areas. Thus, there is now no connection between the numbering of the corps areas and the various corps headquarters of the Field Army.

b. These corps areas were then divided into 26 divisional stations, numbered in Arabic from 1 to 26, 12 of the 14 corps areas having two divisional stations each, the other two corps areas having but one. All the divisions of the army are affiliated for the purpose of training and replacement with one or the other of these divisional stations. It is the responsibility of the divisional stations, under the direction and supervision of the corps area command concerned, to provide trained replacements for the divisions with which they are affiliated.

c. At the conclusion of the California Expedition, the Aggressor Army with the exception of the Fourth Army, which remained behind in the Caribbean area, returned to the homeland for training and garrison duties, and to maintain and improve the internal security of the new

ACCESSOR TERRITORIAL ORGANIZATION

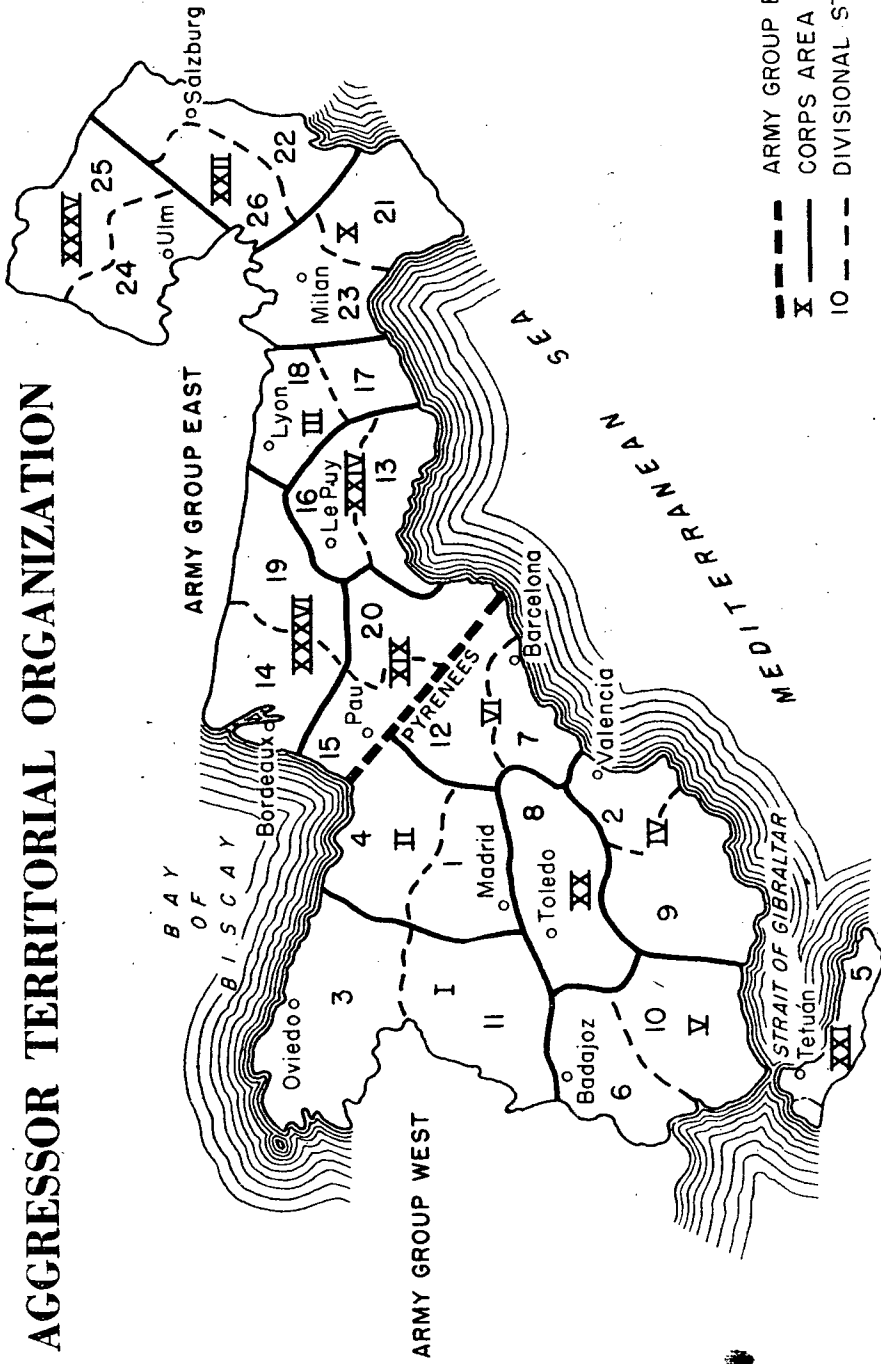

nation. Army Group West was stationed in the western part of Aggressor in what was formerly Spain and Spanish Morocco; Army Group East established itself in the eastern part comprising southern France, northern Italy, Bavaria, and the Tyrol (fig. 4). The Pyrenees mountains form the boundary between the two army groups; the Fourth Army remains under the operational control of Army Group West.

d. Seven of the corps areas and 12 of the divisional stations lie in the area of Army Group West, and 7 corps areas and 14 divisional stations in the area of Army Group East. The corps areas themselves come under the Commander of the Replacement Training Army, while the tactical control and administration of the field divisions is exercised by the corps or army headquarters to which they are assigned. These higher headquarters are established in principal cities throughout Aggressor, but have no administrative control over the corps areas in which they are located. The following is a list of the corps areas, location of their headquarters, divisional stations, and affiliated divisions; the headquarters location of the first divisional station listed under each corps area is also the location of the corps area headquarters.

Corps area	Headquarters	Divisional station	Divisions
I	Oveido	3	5, 87 Mtz; 1 Fus; 31 Armd; 18 Arty
	Salamanca	11	12, 19 Inf; 2 Fus; 1 Mecz; 26 Arty
II	Madrid	1	1 Inf; 3, 4, 10 Fus; 9, 15 A/B; 10 Cav; 5 Arty
III	Bilbao	4	3 Inf; 61 L; 96 Mtz; 7 Fus; 20 Arty
IV	Lyon	18	62 L; 109 Mtz; 53 Arty
	St. Tropez	17	54, 106 Inf; 52 Arty
V	Valencia	2	7 Inf; 94 Mtz; 15 Mecz; 17 Arty
	Santafe	9	9 Inf; 23 L; 3 Mecz; 25 Arty
VI	Badajoz	6	6; 59 Mtz; 33 Armd
	Sevilla	10	10, 21 Mtz; 2 Mecz
X	Barcelona	7	14 Inf; 15 Mtz; 32 Armd; 21 Arty
	Tarragona	12	8 Inf; 58 Mtz; 39 Armd
XIX	Milan	23	71 L; 50 Armd
	Bologna	21	119 Inf; 66 L
XX	Pau	15	18, 91 Inf; 38 Arty
	Albi	20	64 L; 115 Mtz; 14 Cav
XXI	Toledo	8	2, 51 Inf; 40 Armd; 4 Mecz; 31 Arty
XXII	Tetuan	5	4 Inf; 60 Mtz; 30 Armd
XXIV	Salzburg	22	67 L; 42 Armd
	Innsbruck	26	85 Inf; 23 Arty
XXXV	Le Puy	16	52, 105 Inf
	Montpellier	13	11, 86 Inf; 24 Arty
XXXVI	Ulm	24	80 Inf; 16 Mecz
	Regensburg	25	83 Inf; 21 Mecz
	Bordeaux	14	13, 90 Inf; 36 Arty
	Clermont	19	63 L; 110 Mtz; 12 Cav
	Unlocated units		43 Armd; 30 Arty

e. GHQ and Corps special unit replacement training stations are established throughout the corps areas by the chiefs of branches concerned, under the supervision of the Chief of Training of the Replacement Training Army.

12. FUNCTIONS OF THE HOME COMMAND (ARMY GROUP R). The functions of the wartime command for the Zone of the Interior may be described as threefold:

a. Personnel. Conscription, training, and replacement of personnel include control of mobilization policies and the actual call-up and induction of men; all types of military training, including the selection and schooling of officers and noncommissioned officers; the dispatch of personnel replacements to field units in response to their requisitions; and the organization of new units.

b. Supplies and equipment. Design, procurement, acceptance, and storage of supplies and equipment of all kinds, and their dispatch to the Field Army involved; assessment of the future needs of the field; planning of production; obtaining the necessary raw materials and labor; development and testing of new weapons; fiscal matters; maintenance of suitable storage and transport facilities, and of headquarters to control them; and organization of the channels for supply requisitions and deliveries.

c. Administration. Administration of the permanent military installations in the Zone of the Interior and emergency defense of the home territory also are responsibilities of the Home Command. The latter function (which would become operative, for example, in case of a surprise airborne invasion of Aggressor) would be exercised by the Home Command only until an adequate Field Army force could be assembled to take charge of the operations. As explained in paragraph 10, however, the Home Command is always responsible for maintaining a Home Army to be used as a final reserve in the event of a large-scale invasion. The above functions of the Home Command are discussed in detail in sections IV and V of this chapter, and in chapter 6.

13. ORGANIZATION OF THE THEATER OF WAR. **a.** On the outbreak of war, all the parts of the world, both land and sea, which might be the scene of operations become, from the Aggressor point of view, the Theater of War. Within this area, there is a distinction between the Theater of Operations, where military operations can be expected to take place, and the Zone of the Interior, which is the Aggressor homeland and its adjacent waters. Since, in the Aggressor concept, wars should be conducted as far as possible beyond one's own frontiers, the military nomenclature also provides for an intermediate area known as the Zone of Military Administration or Occupied Territory.

b. The Theater of Operations itself is divided into the Combat Zone and the Communications Zone, similar to our policy of field administration. The latter may be entirely taken up by the Army Rear Areas or, if the line of communication is long, its rearward part may be the Army Group Rear Area. Each of the above subdivisions of the Theater of War is subject to a different type of administration by the military, mixed military and civil, or only the civil authorities.

c. The Zone of the Interior is, in general, the area under the Home Command. Special regulations provide for the division of authority whenever units or installations of the Replacement Training Army are stationed within the Theater of Operations, as might happen in the case of invasion of Aggressor. In such cases, the field commander has no authority over the units or installations in question; he may not conscript Aggressor males found in the area nor make requisitions of horses or motor vehicles, for example, as this would upset the long-range and nation-wide program of the High Command for the utilization of personnel and equipment. Only under absolute military necessity may a field commander assume control of units or installations of the Replacement Training Army, and he must then immediately notify the Commander of the Replacement Training Army. The latter, on the other hand, must consult the field commander on any matter of fundamental importance affecting the area of joint interest. This arrangement well illustrates the careful distinction which Aggressor makes between the functions and authority of the Field Army and those of the Home Command.

d. Within the Communications Zone of the Theater of War, the Army Group Rear Area (when it exists) is placed under the authority of a Commander of Army Group Rear Area, who has the status of a corps commander and is responsible to the Commander of the Army Group. His main tasks are to provide for the military administration of the area and to protect the security of the lines of communication so that the army group commander can devote himself entirely to combat operations. Similarly, the Army Rear Area is controlled by a Commander of Army Rear Area with the status of a division commander. The rear area commanders have at their disposal anti-aircraft and security units and police troops, and set up various types of administrative headquarters.

e. In occupied territory, or the Zone of Military Administration, the administrative structure is distinct from the operational control of any Aggressor combat units stationed in it. Distinct from both these commands are any Replacement Training units which might be stationed there; these units remain under the control of the Commander of the Replacement Training Army in Madrid for training and replacement purposes. The form of Aggressor military control of an occupied territory is always dependent on the strategic needs, as well as on the political, economic, and psychological factors.

Section IV. FUNCTIONS OF THE CORPS AREA

14. INTRODUCTION. a. As has been shown, the Home Command is responsible for the replacement of personnel, the procurement of supplies and equipment, territorial administration, and wartime emergency defense. Most of these functions are exercised through the regional corps areas, which are the permanent basis for the servicing, administration, and maintenance of the Aggressor Army. All the corps area functions except those which deal with supply are discussed in this section. In most of these personnel and administrative matters, the corps areas are directly subordinate to the Commander of the Replacement Training Army who acts as an intermediate control for the Home Command.

b. A few functions of the Home Command are performed on a basis other than the territorial one of corps areas and are not included here. By far the most important of these is the procurement, acceptance, storage, and issue of supplies and equipment; for this function the Home Command works through the intermediate control of the Chief of Supplies and Equipment who controls all the army supply agencies. This function is discussed in detail in chapter 6.

15. CORPS AREA RESPONSIBILITIES. The functions of the corps area headquarters may be divided into those which it performs as a territorial command and those which accrue to it as a subordinate headquarters of the Replacement Training Army. As a territorial command, it is responsible to the Armed Forces High Command and has responsibilities affecting all three branches of the Armed Forces. In its other capacity, it is under the Army High Command alone, and is responsible for the replacement training system for all the field units which are affiliated with it. The following are the principal responsibilities of this combined headquarters:

a. Conscription of manpower, carried out through a system of conscription offices. (See sec. V of this chapter.)

b. Training, conducted in conjunction with the chiefs of branches concerned, and under the direction of the Chief of Training in the Replacement Training Army; this training is conducted in training units which come under controlling staffs of regimental (*Home Centers*) and division (*Divisional Stations*) status and in military schools. (See sec. V.)

c. Replacement of personnel for the affiliated field units and formation of new units. (See sec. V.)

d. In time of war, local defense is provided for, in the first instance, by the defense units of the Peoples Militia of the Home Army. Such units are controlled by administrative division staffs set up by Army Group R (*Home Command*); in time of war, one such staff is to be

set up in each corps area. These militia units provide guards for vital installations and for prisoner of war camps, and furnish personnel for local garrison battalions and companies. In case of emergency, the corps area commander has extraordinary powers over civilian agencies as well as the military units and installations in his territory. He may then, for example, issue orders to the provincial and local authorities, commandeer transport and supplies, and take any other steps necessary until outside help arrives.

e. Any GHQ or Corps special units of the Field Army, which are temporarily stationed in the corps area during wartime when their controlling headquarters are in the field, are controlled by the corps area headquarters through its special administrative division staff or other appropriate command channel.

f. Auditing of the accounts of all field units affiliated with the corps area is another responsibility.

g. All military personnel, regardless of their own unit affiliation, are subject to the curfews and other disciplinary regulations issued by the local garrison commander within the corps area. These regulations are enforced by a police patrol service maintained by the corps area headquarters, as well as by the garrison headquarters. In all territorial matters, the corps area commander has a large degree of autonomy. He allots units to garrisons and determines the areas controlled by the garrison commanders. He also controls the Corps Area Administration and its subordinate administrative offices so far as their activity concerns the troops stationed in the corps area.

16. CORPS AREA HEADQUARTERS ORGANIZATION. The various responsibilities of the corps area commander and the corps area headquarters are reflected in the composition and functions of his regular staff and attached special command staffs.

a. In principle, the staff is organized like that of an Army Group or Army headquarters. (See fig. 8.) The differences result from the fact that it has not an operational, but a replacement mission; furthermore it is not a mobile, but a static organization. Thus, the Operations and Training Section (I) is concerned not with operations but with the primary mission of giving recruits basic training, working in conjunction with the chiefs of branches concerned who maintain training staffs in all corps areas. The Supply and Administration Section (II) is concerned mainly with the supply of manpower and with sending replacements to the Field Army. The Intelligence Section (IV) is not primarily concerned with obtaining information about the enemy, but with counter-intelligence and security. The staff is headed by a Chief of Staff and includes the following sections:

(1) Section I is responsible for such matters as training, quarters, air raid protection, gas defense, transportation, training films, surveying and

mapping, engineer units, and technical supervision of utilities in military installations. Signal matters are handled in this section by the Corps Area Signal Officer. He in turn has a staff of his own concerned with training, activation, and replacement of signal units, supervision of radio traffic, static telephone installations, signal equipment, and female auxiliaries. All the combat arms maintain training staffs in each corps area, and the various chiefs of these special training staffs are on duty in corps area headquarters, working under the general supervision of Section I.

(2) Section II handles all supplies and equipment matters for units not part of the Field Army, which are stationed in the corps area. As an echelon in the control of manpower, this section supervises the conscription offices and is responsible for issuing the orders for the transfer of replacements to units of the Field Army in response to their requisitions.

(3) Section III (Organization) works with the chiefs of the various training staffs and Section I on matters of reorganization of existing units, the formation and organization of new units, and submits these recommendations to the chiefs of branches concerned in the Army High Command and the General Staff Organization Section (III). This section is also responsible for planning any reorganization of the corps area itself, and any suggested changes in the internal structure of the corps area headquarters itself. It works in close cooperation with Section I on all organization matters pertaining to formation of combat teams, combat groups, or special army task forces.

(4) Section IV handles counterintelligence and security to the limited extent that the corps area headquarters participates in these activities. It also is concerned with Armed Forces propaganda and press relations, as well as the training and employment of interpreters.

b. In addition to the general staff sections outlined above, there are the special staff sections which are always found in large headquarters; the more important groups are discussed below.

(1) The Corps Area Supply and Administration Officer (II) has an elaborate organization to assist his office similar to that described in paragraph 9a(2). These staff officers perform the same function in the corps area administration that their general staff counterparts do for the entire army structure.

(2) On the staff of each corps area headquarters, there is a Welfare Section which controls the activities of welfare officers who give advice and assistance to professional soldiers who are discharged or about to be discharged. All discharged non-professional soldiers are taken care of by the Ministry of Labor. This section represents that part of the Aggressor Welfare and Pensions organization which is administered by the corps area commander. The Welfare and Pensions Office is a branch of the Armed Forces Administration Office, with the Welfare Section working through the Army High Command to reach the corps area headquarters. The other part, the Pensions Section, is handled on a different

level, the chain of command going from the Armed Forces High Command to three regional Pensions offices located as follows:

- (a) Madrid, for the Spanish and Arab peoples.
- (b) Lyon, for the French and Italian peoples.
- (c) Munich, for the Teutonic peoples.

There is one Welfare Office and one Pensions Office in each corps area. The branch Welfare Office comes directly under the corps area commander, the chief of the Welfare Office being a staff officer at corps area headquarters as explained above. The branch Pensions Offices, which do not form part of the corps area organization, grant pensions for discharged professional soldiers and their dependents. The reason for the separation of these offices from the control of the corps area commander is the desire to achieve uniformity in the administration of pensions throughout Aggressor.

(3) Also attached to the staff of each corps area headquarters is a Commander of Prisoners of War who is in charge of all prisoner of war camps in the corps area. This commander is a deputy of the Armed Forces Chief of Prisoners of War Office, and acts on all matters pertaining to Aggressor or foreign prisoners of war emanating from his corps area.

(4) Finally, there is an Officer for Military Economic Affairs who handles, for the corps area commander, all questions of military economy having a territorial bearing. He is, at the same time, a direct representative of the Armed Forces Economic Office in the Armed Forces High Command and liaison officer to the regional offices of the Chief of Supplies and Equipment.

17. GARRISON HEADQUARTERS. a. The local territorial responsibilities of the corps area commander are exercised through Armed Forces Senior Garrison Officers. In garrisons with permanent headquarters, or on maneuver areas, the commander is automatically the senior garrison officer. If the majority of the units or installations in a garrison belong to the Navy or Air Force, the senior garrison officer may be taken from these branches of the Armed Forces instead of from the Army, but he remains subordinate to the corps area commander.

b. The area of the garrison town and its immediate vicinity is designated as the garrison district, its boundaries being fixed by the senior garrison officer with the approval of the corps area commander. Within this district, the senior garrison officer is fully responsible for discipline, local defense, and related matters on behalf of the entire Armed Forces; enlisted personnel, for example, require a pass to leave the garrison district. All parts of the corps areas which are not included in garrison districts are allotted by the corps area commander to so-called garrison areas, which are placed under the control of existing senior garrison officers for the exercise of the same functions as within the districts.

If there is an airport within the garrison district, it is treated as an autonomous district and placed under the command of an Air Force officer.

c. The senior garrison officer is authorized to commandeer soldiers and horse-drawn vehicles in his area to do work for the general purposes of the garrison. In case of emergency, he may mobilize special detachments. He also issues regulations for garrison guards and patrols and cooperates with the corps area chief military police officer in controlling police patrol units in his area. He is also responsible for local defense measures, especially for the air raid protection of all installations belonging to the Armed Forces, and for the efficiency of the air raid protective services. The senior garrison officer is responsible for the maintenance of military discipline among all members of the Armed Forces within his territory. All military personnel on leave have to report at the garrison headquarters within 48 hours after their return. He may also declare certain buildings or streets off limits. He cooperates fully with any offices or detachments of the Armed Forces Transportation Corps operating in his area, working in this respect under the direction of Army Transportation Officer at corps area headquarters.

18. CORPS AREA ADMINISTRATION. a. General. All administrative matters in the Aggressor Army are controlled at the top by the Army Administration Office in the Army High Command. Under this office, the administrative agencies within Aggressor are organized on a territorial basis with the Corps Area Administration as the next lower echelon. The chief of this Corps Area Administration is the Corps Area Chief Supply and Administration Officer (II), already referred to above as a general staff officer at corps area headquarters. Below this, these matters are handled by the local garrison administrations and other specialized types of local administrative agencies. This entire system operates independently of the tactical chain of command which runs as follows: Army High Command—Army Group R (Home Command)—Commander of Replacement Training Army—Corps Area. The supply and administration functioning within the corps area is divided into separate branches as under the General Army Office in the Army High Command, there being a Chief Administrative Officer and a Supply Officer such as occupy positions on Army Group and Army headquarters staffs. (See fig. 8, page 54.) Below is a chart indicating the chain of command, tactical and supply and administrative (fig. 5).

b. Dual position of the Corps Area Administration. (1) The degree of independent authority of the Corps Area Administration in carrying out its duties depends on the nature of the subject matter, which is divided into two basic categories: those matters in which the Corps Area Administration acts independently of the Corps Area Headquarters and is responsible only to the Army Administration Office in the Army High Command, and those matters in which it acts on the orders of the corps

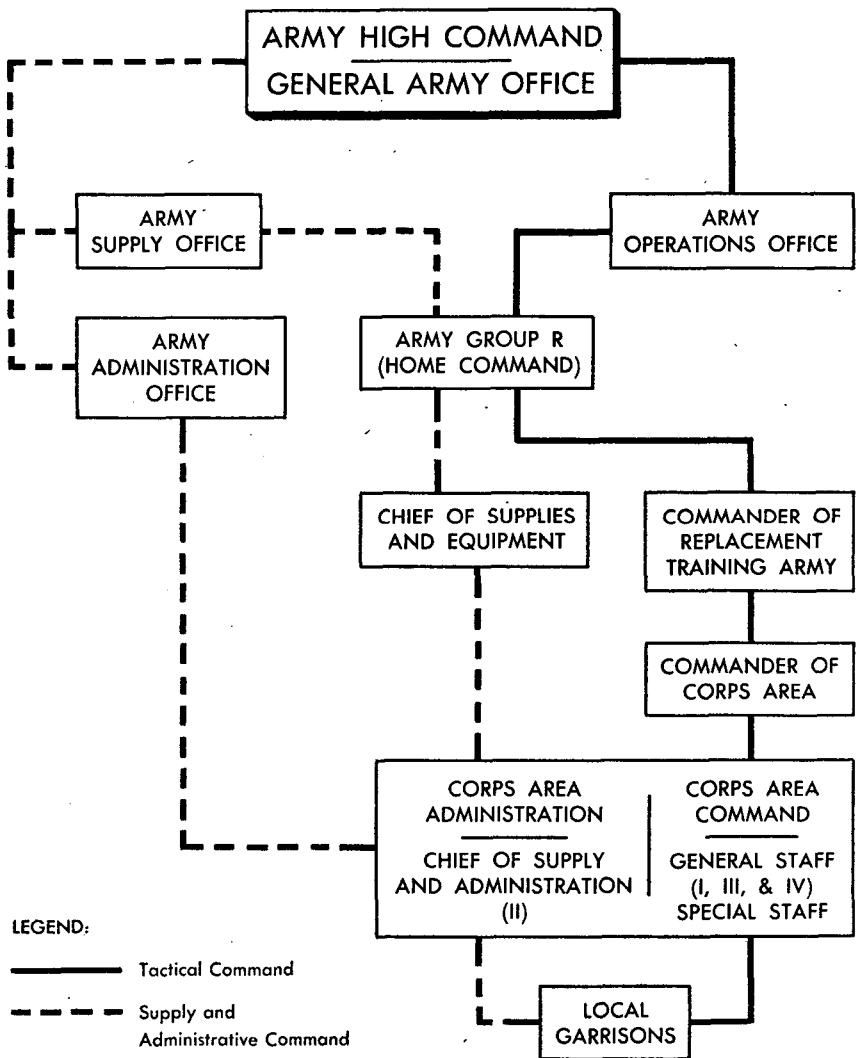

Figure 5. Corps area chain of command.

area commander. In the latter type of subject, the Corps Area Administration functions as the administrative section of the corps area staff, and these subjects are usually referred to as "staff administrative matters." They are mostly matters connected with the administration of the corps area headquarters itself or of the units subordinate to it.

(2) The word "administration" as used throughout the Aggressor Army in a functional sense covers primarily pay, rations, clothing, and

billeting. It must not be confused with the administrative services, or with the technical services which operate under the Chief of Supplies and Equipment in making the above-mentioned items available to the various commands of the Aggressor Army. Chiefs of the various administrative and technical services are represented on the corps area and higher headquarters staffs by staff officers who advise and assist the commander in their particular specialty. The Chief Administrative Officer of the several staffs, however, is in reality the chief of an executive agency which supervises and coordinates the functioning of the several services concerned in the matters of pay, rations, clothing, billeting, and other items of general interest to the command in question.

(3) The matters in which the Corps Area Administration acts independently are those which derive from its status as a responsible echelon in the territorial administrative structure. In these matters, it has its own direct administrative channels, upward to the Army Administration Office and downward to the local garrison administrations. It operates through the proper branch of service, staff office, or governmental department concerned. These independent matters include the following categories:

(a) Pay, accounting, social insurance, and allowances.

(b) Procurement, storage, and issue of utensils and general equipment.

(c) Supervision of the handling of food in processing plants and in the ration depots.

(d) Billeting, so far as it is not determined by the military decision of the corps area commander.

(e) Building and civilian contracts.

(f) Personnel matters of all administrative officers in the Corps Area Administration, its subordinate agencies, and Field Army units maintained by the corps area.

(g) Training of administrative officers.

(4) In principle, this separation into "staff administrative matters" and independently handled administrative matters is carried down to the lowest administrative echelons, although the scope of their independent authority is less comprehensive than that of the Corps Area Administration. This basic division of the administrative authority is characteristic of the dual functions and responsibilities of the administrative service of the Aggressor Army.

(5) The head of the Corps Area Administration is the chief of the General Staff Section II of the corps area commander's staff, carrying the title of Chief of Supply and Administration (II). As head of the Corps Area Administration, he is directly subordinate to the Army Administration Office; as a staff officer, he is subordinate to the Commanding General. He controls staff administrative matters through the Chief Administrative Officer and controls staff supply matters which concern the technical problems of supply through the Supply Officer. Both of these officers are in the supply and administrative group of the staff.

Section V. CONSCRIPTION, REPLACEMENT, AND TRAINING

19. INTRODUCTION. a. This section deals with the entire system of personnel replacement for the Field Army. The units of the Field Army do not procure their own replacements independently. Replacements for the field units are obtained only through the specified units of the Replacement Training Army, and those for the units of the Replacement Training Army in turn come only through the home recruiting stations. Thus, the replacement system can be divided into the following main divisions:

(1) Conscription: the function of the home recruiting stations under the Armed Forces High Command Conscription and Recruiting Office.

(2) Replacement and Training: the primary function of the Replacement Training Army.

b. The following pages describe the machinery for the registration and supervision of those liable to service, their induction and training in one of the numerous replacement training units and schools of the Replacement Training Army, their dispatch to a field unit, and their return to the replacement training unit. The principle of affiliation between field and replacement training units, the fact that developments in the Field Army are often preceded by corresponding developments in the Replacement Training Army, and the fact that units of the Replacement Training Army can fight in the field as a part of the Home Army in the event of an invasion show that, although the Aggressor Army is divided into distinct parts, the Field Army and the Replacement Training Army are closely interlinked and cannot be fully understood, except as complementary parts of a whole.

20. CONSCRIPTION SYSTEM. a. **Historical development.** Systematic universal military training has been adopted in modern times by all the great nations and many of the lesser ones. In many of them, this system operates in peacetime, as well as in wartime. It was originally an invention of the Germans and was developed to its highest degree of refinement by them. Aggressor now has many former high-ranking German officers who were thoroughly indoctrinated in this principle of universal compulsory military service, and the system is firmly established in Aggressor by edict of the government. The conscription system originally grew out of the mass armies which were necessary to overthrow Napoleon and was introduced by a Prussian law in 1814 as a part of the far-reaching reforms initiated by Scharnhorst and his colleagues to cope with the new forms of warfare. Through necessity, in order to survive, the nations of the world have also been obliged to adopt conscription, especially in wartime when tremendous masses of men were needed to fight in the armed forces.

b. **Basic laws.** In the fall of 1945, one of the first acts of the new government was to lay the foundation for a universal compulsory military service for Aggressor. An Armed Forces Law was put into effect which stated that military service was to be based on the principle of universal liability. This was soon followed by a Military Service Law which established the purpose and scope of universal service, administrative control of civilian manpower, categories of manpower according to age and training status, rights and duties of military personnel, and methods of call-up and discharge. As Aggressor was expanded to include new territories, additional decrees were issued to insure the uniform working of the conscription system throughout the country.

c. **Controlling agencies.** The execution of the system for exercising military supervision of men liable to military service and for examining and conscripting them from civilian life into the Armed Forces is a joint responsibility of the Aggressor civilian and military authorities.

(1) *Civilian.* The Ministry of the Interior, controlling all police authorities and the ordinary local registration of the civilian population, is responsible for the registration of men liable for military service. This occurs through the local and district police authorities.

(2) *Civilian and military.* The Ministry of the Interior and the Secretariat for the Armed Forces jointly issue and jointly apply the decree concerning Military Examination and Drafting, which involves collaboration of the civilian and military authorities during the phase between first registration and induction. They are also jointly responsible for dividing each corps area into suitable recruiting areas and sub-areas in such a way as to meet the military needs and to fit, so far as possible, the existing civilian administrative subdivisions of the country.

(3) *Military.* The Armed Forces High Command controls the machinery for the call-up, induction, and discharge of personnel. This includes the recruiting area and sub-area headquarters which examine and draft recruits and represent the military interests in the administrative control of civilian manpower before and after service.

(4) *Chain of military command.* This being a matter which concerns all three branches of the Armed Forces, it is supervised by the Conscription and Recruiting Office in the Armed Forces High Command. Emanating from this agency, orders are issued through the various corps area headquarters to the recruiting area offices and from there to the recruiting sub-area headquarters. These control the Military Reporting Offices and set up from time to time in their districts the examining boards. There is one recruiting area for each divisional station, the divisional station being the basic territorial administrative echelon in the replacement training system. The number of recruiting sub-areas in each area is determined by the number of home centers, the home center being the lowest territorial administrative echelon. Home centers that cover a large area sometimes have more than one sub-area according to local

needs; where there is only one home center in a divisional station, there are always at least two sub-areas. Each recruiting area is controlled by a Chief of Recruiting Area, who is a general officer with the status and disciplinary authority of a division commander. (In some cases, he may be a naval or air officer of corresponding rank, since the recruiting system operates jointly for all three branches.) Recruiting sub-areas are commanded by lieutenant colonels or colonels selected from the class of officers whose suitability for active service in the field has ceased. They have the status of regimental commanders.

d. Classification of manpower. (1) *Basic concept.* "Military service is honorary service to the Aggressor peoples. The first duty of every citizen is to the State; therefore, every Aggressor citizen is liable to military service. In time of war, in addition to liability to military service, every Aggressor male citizen and every Aggressor female citizen is liable to service to the Homeland." These are the opening clauses of the Aggressor Military Service Law.

(2) *Extent of liability.* In time of peace, all Aggressor males are liable to military service from their 18th birthday until their 45th birthday. The Secretariat for the Armed Forces is empowered, in wartime, to extend this age liability in either direction.

(3) *Reserve status.* After a minimum service of 4 years, men no longer needed in the army may be transferred to the reserves. The reserves include all men not doing active military service, and are classified into the following categories:

(a) *Active Reserve I.* Those under 35 who have completed their regular period of active service and have been discharged. They spend 2 months of every year on active duty, similar to our National Guard summer camps.

(b) *Active Reserve II.* Trained men between 35 and 45. These men are subject to recall for short periods for refresher courses or specialized training.

(c) *Inactive Reserve.* Trained men, 45 and over, who have been released from all peacetime military service, and have been transferred to an inactive status. These men are normally released from the reserve and all further military obligations, except in a national emergency, on reaching the age of 60, but may be sooner retired for physical disability. During wartime, they can be used to perform limited service duties in the army, to assist in training new troops in the replacement training army, or to serve as temporary officers and noncommissioned officers in the Peoples Militia.

(d) *Reserve III.* Trained or partially trained men under 35, who are available only for limited service; these men were either discharged for some physical disability, or developed the partial disability subsequent to discharge from the active service.

(e) *Reserve IV.* Trained or partially trained men, 35 to 45, who are

available only for limited service. These men are frequently called upon to aid in the training of the People's Militia or to fill administrative offices in that organization.

(f) *Home Defense Reserve.* At the age of 45, men of the above two classes of reserves are transferred to a home defense reserve which can be used in wartime to fill vacancies or manpower requirements in the Peoples Militia.

(4) *Exclusion.* The following categories of men are described as "unworthy to bear arms" and therefore "excluded from military service":

(a) Those sentenced to penal servitude.

(b) Those subjected to "security and improvement" measures in concentration camps or other special installations to remove the morally, or otherwise unfit, such as habitual criminals, from contact with society.

(c) Those deprived of the "worthiness to bear arms" by a court martial.

(d) Those sentenced for activities inimical to the state.

(5) *Exemption.* Completely unfit men are released from liability to military service. All priests of the Roman Catholic Church, Protestant ministers, Jewish rabbis, and regularly ordained ministers or priests of any other religion are exempted from military service, and subject to call only to serve as a chaplain in their respective faiths. Regularly enrolled divinity students in accredited religious schools studying for the ministry are also exempt. No other category of person is exempt.

(6) *Deferment.* No Aggressor can be deferred for military service in peace or war for purely personal reasons or by reason of his dependency status, except in cases of extreme hardship. He may be deferred, however, by reason of industrial, scientific, or agricultural necessity in order to support or supplement the national war effort. Deferment of indispensable employees in industrial establishments not directly connected with the war effort may be applied for by the employer, but it is granted only according to a quota system or until suitable factory replacements can be trained. No general class of men is deferred, and each case is judged on its merits. Application for deferment must be repeated at stated intervals.

e. Conscription procedure. (1) *Registration.* Usually in the spring of each year, under directives issued by the High Command, the incoming class (those who are turning 18 during the year) is summoned by the district police authorities by means of public notices to appear at the local police stations for military registration. It should be noted that under the Aggressor administration system, the local police always have a complete roster of all residents of their precincts, based on the required registration of residents.

(2) *First examination.* Shortly after the registration, the recruiting sub-area headquarters issues orders for the holding of the first examination of the registrants. This is carried out according to local registra-

tion districts by an examining board which includes representatives of the military authorities, the district and local police, the civilian administrative authorities (municipalities or rural districts), and the Aggressor Labor Service, as well as medical officers. On this occasion, the registrants are classified according to their physical fitness. The following categories are used: fit for regular service; fit for limited military service; fit only for labor service; totally unfit; and temporarily unfit. Medical standards have been rigidly enforced as regards the Armed Forces personnel.

(3) *Drafting.* Final action on the question of whether or not an individual is to be called up for regular service is taken at a second examination or drafting. This is conducted by the same authorities as the first examination and results either in a deferment or in definite assignment to a branch of service. The registrant then returns home and awaits orders.

(4) *Call-up.* The actual call-up is issued by mail by the recruiting sub-area headquarters in the form of an induction order directing the registrant to report at a specified time at the headquarters of a replacement training unit. During wartime this procedure is speeded up, and the drafting is usually combined with the call-up.

(5) *Induction.* Recruits reporting at a replacement training unit headquarters are first subject to roll-call then distributed to companies where the final medical examination and actual induction take place. Induction is followed by a mental and physical test to determine the most suitable employment of each man, and the administration of the oath of allegiance.

(6) *Volunteers.* Volunteer applicants for permanent officer and non-commissioned officer careers apply at reception centers for potential officers and noncommissioned officers, which come under a central office at the headquarters of the Commander of the Replacement Training Army. Within limits, the volunteers are given the privilege of selecting their arm or branch of service. There is one such office at each corps area headquarters, with branch offices in all major cities throughout the corps area.

(7) *Discharge.* Discharge-before completion of the normal period of service is possible if a man becomes "unworthy to bear arms" (by reason of conviction for a major criminal offense) or totally unfit, or if it is discovered that he had been inducted by error. Both this type of discharge and the normal discharge (in peacetime) after 4 years of service are carried out by the unit itself. In wartime, this is modified to some extent. In order to be discharged from active service, members of the Field Army must be transferred back to their affiliated units of the Replacement Training Army, either by their own units or by a hospital. In order to relieve these units of as much administrative detail in wartime as possible, however, and to reduce the distance which the infirm

soldier must travel to his place of discharge, army discharge centers are established during wartime to handle medical discharge cases.

(8) *Foreigners.* Foreigners, especially those of military experience, are always welcomed into Aggressor for the purpose of volunteering for service in the Aggressor Army. They attain automatic citizenship on being sworn into the military service. Most of the high-ranking officers of the Aggressor Army are from other parts of Europe, especially from Germany.

f. Handling of conscripts. (1) The three branches of the Armed Forces submit to the Armed Forces High Command, their personnel requirements on the 15th of each month for the second month following. According to the demands and the general replacement situation, the various corps area headquarters then receive orders from the Conscription and Recruiting Office of the Armed Forces High Command specifying how many men and women (in wartime only) are to be inducted for each branch of the Armed Forces. This office also determines which age groups are to be drawn upon according to the type of service for which they are required. The corps area headquarters are bound by these arrangements, but may accept volunteers of all age groups. If men of a certain type are not available within the corps area where they are required, the Armed Forces High Command may order the transfer of recruits from one corps area to another. Within the corps area, the corps area headquarters is responsible for distributing the replacement requisitions among the recruiting area and sub-area headquarters as rapidly as possible and with due regard to the varying characteristics of the population in different districts. City areas provide the best material for motorized units, country areas for cavalry and horse-drawn units. A mixing of rural and urban elements is to be aimed at in the interests of regional and national solidarity.

(2) The Navy accepts volunteers from all parts of the country. For its seagoing personnel, it has a priority on recruits who, by reason of their place of residence or previous experience, are classified as belonging to the "seafaring population"; to man its shore installations, it takes conscripts from the maritime provinces, that is, those which have a coastal area. The Air Force has a similar priority on conscripts classified as part of the "aeronautical population," which includes those who have belonged to gliding or aviation clubs, especially youth organizations.

(3) The Army aims at assigning every individual conscript to the type of unit for which his physical condition, his civilian background, and his special abilities best fit him. In general, transfers from one corps area to another are not made unless there is a cogent reason for them; they are not frequent, and occur usually only in wartime when growing manpower difficulties might make it impossible for some corps areas to meet their obligations from their own resources. In principle, a conscript trains and fights in the company of men from his own province.

21. REPLACEMENT TRAINING SYSTEM. a. Basic principle. (1) Every unit in the Field Army is affiliated for personnel replacement purposes with a specific unit of the Replacement Training Army, located in its own original home center. Conscripts as a rule are placed in replacement training units in their own home center (recruiting area), but in war-time or special manpower emergencies may be transferred to another home center in the other divisional station (where one exists) of the corps area at the discretion of the corps area commander concerned. The function of the replacement training unit is to induct recruits, to provide for their training, and to see that they are held in readiness to be sent off to the affiliated field unit in groups or individually, as required.

(2) The normal location of the replacement training unit is the home station of all the field units affiliated with it. All soldiers ultimately return or expect to return to the replacement training unit for their discharge or reassignment. For example, a soldier who is wounded and goes to a hospital in the Zone of the Interior will be sent, on leaving the hospital, to his affiliated replacement training unit before being returned to the field.

(3) Whenever feasible, trained replacements are sent by the replacement training unit to a field unit with which it is affiliated. If for any reason, however, a man is diverted to a different field unit, or if he is subsequently transferred from one field unit to another which does not have the same affiliated replacement training unit, proper entry is made in his service record to show his present or temporary affiliated replacement training unit. The soldier is returned whenever practicable or desirable to his proper field unit as soon as possible. The above temporary entry is then corrected and the number of his original replacement training unit is again indicated in his service record.

b. Organization of the replacement training system. When the Aggressor Army was originally organized, each divisional station was called upon to furnish a certain specified number of divisions. To keep the units of these divisions at full strength, replacement training units were set up. These replacement training units bore the numbers of the divisional units of the first division organized in each divisional station. They were distributed according to population among the various home centers of the divisional station concerned. As additional divisions were formed, the replacement training units already in existence were called upon to fill the personnel needs of the new division whenever possible. When a new division of any divisional station had units of a branch of service or type of unit not found in any previously organized division in that divisional station, it was necessary to set up additional replacement training units to service those elements of the new division. The field units and the replacement training units were said to be "affiliated," and the field units which the replacement training unit maintains in the field are known as affiliated field units. The battalion is the basic administrative

unit of the replacement training system, there being as many battalions as necessary in the replacement training unit to accomplish its mission of maintaining the affiliated field units at field strength. [When the units of a division are of regimental strength, the affiliated replacement training unit will be of regimental status, and have a regimental staff. When the units of a division are of company or battalion strength, the replacement training unit will be of battalion status, and have a battalion staff. At any given time, the battalion includes one or more of each of the following types of companies:

(1) Reception companies, consisting of new recruits and cadre personnel.

(2) Training companies, for the training of the inducted untrained conscripts.

(3) Transfer companies, which are pools of trained replacements ready to depart for the field unit.

(4) Convalescent companies, consisting of men released from Zone of the Interior hospitals who are being prepared for return to the field.

c. Affiliation system. A regiment replacement training unit was set up for each regiment of the first division formed in a divisional station, a battalion replacement training unit for each divisional unit of battalion size, and a company replacement training unit for each divisional unit of company size. Thus, the infantry regiments of the infantry division would have infantry regiment replacement training units bearing their respective numbers, the artillery regiments would have artillery replacement training units bearing their numbers, and the reconnaissance company would have a reconnaissance company replacement training unit bearing its number. (See par. 22b.)] Replacement training regimental staffs are commanded by colonels, replacement training battalion staffs by lieutenant colonels. The replacement training systems for all the other types of divisions are similarly organized. Replacement training units already in existence are utilized whenever possible; if none exist, then training units are set up.

d. Chain of command in the Replacement Training Army. (1) The replacement training units are subordinate to the corps area commander, who is in turn subordinate to the commander of the Replacement Training Army, the latter being under the control of Army Group R, the Home Command. The Chief of Training of the Replacement Training Army supervises and coordinates the training, working in conjunction with the representatives of the chiefs of branches concerned; these representatives are known as Inspectors, and are responsible for the efficiency of the replacement training units under their control. As stated before, the GHQ and Corps Troops replacement training units come under the direct control of the chiefs of branches concerned, although the Chief of Training referred to above also exercises general supervision over these units. The affiliated field units in this category, however, deal direct

with the Commander of the Replacement Training Army when requesting replacements, and not through the corps area commander as in the case of the affiliated divisional field units. (This subject is covered in *e* below.)

(2) The Commander of the Corps Area has the right to shift the location of the divisional units of the Replacement Training Army in his area, but must notify the Commander of the Replacement Training Army. He has no such power over the location of the GHQ or Corps Troops replacement training units, but can forward a request through the Commander of the Replacement Training Army to the chief of branch concerned for a change in location of the replacement training unit in question. The responsibility of the Commander of the Replacement Training Army and of his subordinate headquarters and offices for maintaining the Field Army up to its prescribed strength remains in effect even when parts of the Replacement Training Army are located in the Theater of Operations, as might happen in case of an invasion of the Aggressor homeland.

(3) To facilitate higher tactical or combined arms training of the replacement training units, there are Replacement Training Division Staffs which control the various divisional replacement training units assigned to its area; very often GHQ or Corps Troops replacement training units are placed under these staffs for maneuver and tactical training in conjunction with other arms and services. These division staffs are subordinate to the corps area commander, and are controlled by the Chief of Training in the Replacement Training Army, whose main job is the coordination of the training by the different branches of service.

(4) The number of replacement training division staffs in each corps area is regulated by the Army High Command. They are responsible for the uniformity of training in their subordinate replacement training units. They are kept free from all administrative duties. Regarding correspondence, they are to participate only in what concerns the training, arming, and equipping of replacement training units, maintenance of discipline (including proceedings of law), and the personal matters of their subordinate officers and officials. Should there be several replacement training division staffs in one corps area, the corps area commander orders which replacement training units are subordinated to either one.

e. Requisitioning of replacements. (1) The field unit may request replacements when there is a deficiency of more than 10 percent of their table of organization strength. Replacements for specialists, such as communication personnel or technicians, are to be requested as soon as their absence would hamper the efficiency of the field unit. The requests for replacements by the various components of the division go through channels to the division headquarters (*Personnel Officer*). The division for-

wards them direct to its divisional station back in the Aggressor homeland. The divisional station commander thereupon issues orders to the appropriate replacement training units. The replacement training division staffs usually are consulted only with regard to the state of training of the replacements before they are disposed of. The commanders of the replacement training unit staffs participate fully in this matter. If the records which every divisional station headquarters has to keep, show that the replacement training unit concerned cannot provide all or any of the replacements, it passes this order to another replacement training unit in another home center of the divisional station. If an adjustment is not possible within the divisional station concerned, the corps area commander is notified; if possible, the corps area commander orders the other divisional station (where there is one) to provide the replacements. If there is no other divisional station in the corps area, or the other divisional station cannot supply the replacements, then the Commander of the Replacement Training Army is notified, and he selects the corps area to provide the necessary replacements.

(2) Although the requisitions are strictly channelized, direct relations between the field unit and the affiliated replacement training unit at home always are considered desirable, in order to strengthen the feeling of comradeship. This is achieved not only through the personal connections, but also through circular letters and newspapers.

(3) Requests for replacements for GHQ and Corps Troops units go directly to the inspector of the branch concerned in the office of the Commander of the Replacement Training Army. This inspector notifies the proper affiliated replacement training unit; if his records show that the affiliated unit cannot provide the replacements, he orders another replacement training unit to fill the requisition. This changing of the affiliated units is kept at a minimum, and the necessary adjustments made as soon as possible whenever practicable.

22. TRAINING. a. Introduction. (1) *Types of training establishments.* The general military training of the Aggressor soldier takes place principally in the training units of the Replacement Training Army, although a certain amount of training also is given in its replacement units (the transfer or convalescent companies of the replacement training battalions). Training units also are prepared to conduct special courses in order to provide some types of specialized personnel, as required by the Field Army, and to secure a pool of personnel trained with particular care as potential officers and noncommissioned officers. In addition to these general training units, numerous schools and courses have been established with the specific purpose of training potential officers and noncommissioned officers. Other schools, designated as special service schools, have the function of providing specialized training for officers and enlisted men of their particular branch of service, developing its

arms, equipment, and tactics with the help of their demonstration units, and furnishing instructors for the Army. In addition, specialist training schools are established to provide instruction for ordnance officers, technical officers, and particularly noncommissioned officer technicians, and for officers and noncommissioned officers of all arms and services as specialists in certain particular functions, such as air raid and gas protection.

(2) *Chain of command.* (a) The training in most types of replacement training units, which are under the command of the corps area headquarters exercised through intermediate staffs, is coordinated by the Chief of Training in the Replacement Training Army. He exercises his authority through the Inspectors of Arms and Services who act as the representatives of their respective chiefs of branches in the office of the Chief of Training. The inspectors issue directives regarding the particular training in their arms to the corps area headquarters. These directives are based on tactical doctrines worked out in detail by the offices of the chiefs of branches in the Army High Command, working in conjunction with the chiefs of general staff sections concerned. New or changed doctrines are worked out as the need arises in the field, as changed conditions of warfare indicate the necessity for revision, and in accordance with the recommendations and suggestions of the inspectors of arms and services on duty with the Chief of Training.

(b) The training of medical troops is directed by the Medical Inspector who is under the direct control of the Surgeon General, but comes under the Chief of Training for the tactical purpose of fitting the medical units into the general training scheme. The veterinary troops come under a Veterinary Inspector in the same way. The technical training of the engineer and signal troops comes under their respective inspectorates which are responsible to their chiefs of branches, but their tactical training within the division, corps, or army, is supervised and coordinated by the Chief of Training working through the inspectorates.

(c) The training of potential officers and noncommissioned officers, wherever it occurs, takes place under the command or supervision of the Inspector for Potential Officers and Noncommissioned Officers who is subordinate to the Commander of the Replacement Training Army. The authority of this inspector is restricted to supervision when this type of training takes place in establishments under the command of the Chief of Training or any corps area headquarters. The chiefs of branches concerned maintain representatives on the staff of the Inspector for Potential Officers and Noncommissioned Officers as technical advisers. Special service schools and special training schools are under the command of the Chief of Training, but are supervised by any chiefs of branches concerned.

(3) *Supplementary training.* The paragraphs below describe how the various types of training units and schools discharge their functions. It should be kept in mind that these functions are supplemented in

many ways. A considerable part of military training in Aggressor is given in the form of pre-Army training by other military and auxiliary organizations. Special abilities found in various civilian occupations are put to use by the Army, and only personnel with a certain professional background are trained for technical employment within the Army. Civilian establishments sometimes are used for the training of Army personnel. For example, technical courses often are conducted in factories producing special types of equipment. The entire Aggressor technical and industrial establishment is at the disposal of the state for any purpose whatsoever.

b. General training. (1) *Organization of training units.* In principle, the training unit of the replacement training system is a true image of the field unit which it supplies with trained replacements. Thus, the infantry regiment replacement training unit contains one or more infantry training regiments which are true images of the affiliated infantry regiments in the field; the reconnaissance company replacement training unit contains one or more reconnaissance training companies which are likenesses of the affiliated reconnaissance companies in the field; the same principle would also hold true for units of battalion size. For administrative purposes, the size of the replacement training unit itself is determined by the number of affiliated field units which it services. Thus, if there were two or more infantry training regiments in the infantry regiment replacement training unit, there would be a brigade administrative staff; a battalion replacement training unit would have a regimental administrative staff if there were two or more battalions; a company replacement training unit always has a battalion administrative staff, since the lowest administrative replacement training unit is of battalion status (see par. 21*b* above).

(2) *Program in training units.* (a) The main responsibility for the training of recruits rests with the commander of the training unit of company size (company, battery, troop). The detailed training schedule is prepared within the framework of the company. The battalion commander supervises the progress of the training in the companies of his battalion and inspects the recruits at the end of their basic training. The commanders of higher echelons coordinate the training in the units under their command and supervise it. They are also responsible for the education and training of officers and potential officers and non-commissioned officers within these units. The latter are often placed in special companies within the training battalions and regiments, or within special platoons in the training companies which have no higher training echelon.

(b) The length of the period of basic training is determined by the chief of branch concerned in conjunction with the Chief of Training, taking into consideration any special exigencies which may affect the length of time which can be spent in training. In wartime, it is usually

speeded up. This period of basic training may be followed by an indefinite period of advanced training lasting up to the time of transfer of the recruits to a field unit. In peacetime, the training continues throughout the entire 4-year period of military service, but in wartime the recruit must be ready for full field duty and operational service within 6 months (or less). During the advanced training period, the scope of training is amplified to include combat team training and combined arms training on divisional level.

(3) *Training in replacement units.* (a) Although according to their organization basically not equipped for training purposes, the replacement units nevertheless perform training functions on a reduced scale. This is done in the following manner. After transfer from a training company to a transfer company (trained replacements ready for the field), the men are organized into provisional groups, given refresher courses, and tested for the possibility of future specialized work or promotion to the noncommissioned officer grade. They are kept active in light training so as not to lose the physical fitness which they developed in the training stage of the replacement training system. They keep active physically, go to lectures, practice firing their weapons, drill, and indulge in sports. They also run special combat courses similar to our infiltration courses to keep up their combat training.

(b) Regular training functions are performed in the convalescent components of replacement units. Their purpose is to restore the health and physique of convalescents until they regain full fitness for field duty, and also to select and train instructors for the training units. For the latter purpose, special courses are conducted by the convalescent units. After regaining their fitness for field duty, the convalescents are sent to the transfer components of their replacement units, where they are given advanced training until the time of their transfer to a field unit.

Section VI. THE PEOPLES MILITIA

23. ORGANIZATION. The Peoples Militia is the name applied to a civilian home defense organization which becomes fully operative only in time of war. It is integrated with the national police and is to be used as a final reserve in the event of invasion. Together with the Replacement Training Army, it forms the Home Army for the defense of the homeland. During peacetime, plans are formulated by Army Group R Headquarters (The Home Command) and skeleton staffs are set up to formulate wartime plans for the Peoples Militia. Home defense battalions and companies are organized and cadres of trained discharged soldiers are set up for organization, planning, and training. Former Army officers of the limited service category are placed in command posts, while key noncommissioned posts are held by regularly trained

former noncommissioned officers who are now in the Inactive Reserve. Other noncommissioned posts are given to trained Army personnel who have been discharged because of limited service category or some slight physical disability. In large centers, cadres for entire divisions are set up, and retired high-ranking Army officers are placed in the responsible positions of regimental, brigade, and divisional commanders. This entire organization exists only on paper in peacetime, but at the outbreak of war is recruited to full planned strength in accordance with the principle that all personnel on civilian assignments can be called upon for service in the Armed Forces in case of invasion of the homeland. It cooperates with and assists the wartime air raid protection and fire fighting groups which are well organized throughout the Aggressor homeland during war.

24. PERSONNEL AND EQUIPMENT. It is intended that the officers and noncommissioned officers of the Peoples Militia will be trained soldiers as shown in the preceding paragraph. The rank and file, however, will be the male and female (if necessary) citizens of the Aggressor nation who are not called upon for or are incapable of military service in the Field Army. The backbone of this Army will be former soldiers who are more than 45 years old, and are not called upon for field duty. Local defense companies and battalions in small cities or rural areas will consist of all able-bodied citizens of those places in accordance with plans already drawn up during peacetime. In all cases, the national police of Aggressor will act as a headquarters unit, and local police stations will become command posts for possible operations. Supplies and equipment will be furnished by the Chief of Supplies and Equipment of the Home Command, and the entire transportation system of Aggressor will be coordinated under Army Group R so as to be of the greatest assistance in fighting the invader. Local hospitals, warehouses, and other public buildings will be utilized to the fullest extent in servicing this Peoples Militia.

CHAPTER 2

ORGANIZATION OF THE FIELD FORCES

Section I. HIGH COMMAND IN THE FIELD

25. **GENERAL.** Under the Aggressor military system, the basic principle is unity of command at all levels. The Army, Navy, and Air Force are considered branches of a single service, the Armed Forces. This joint high command is responsible for the preparation of defense in time of peace and for the general conduct of war. It appoints commands for the joint task forces in the field and sees that the efforts of the three branches of the Armed Forces are thoroughly coordinated. The three branch High Commands—Army, Navy, and Air—are under the Armed Forces High Command (fig. 6).

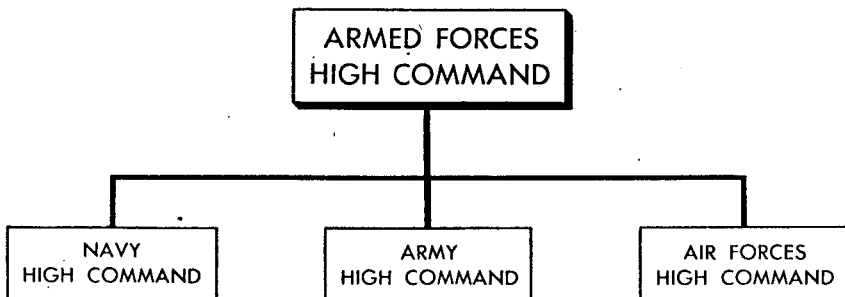

Figure 6. Aggressor high command.

Section II. ORGANIZATION OF THE FIELD ARMY

26. **ORGANIZATION OF ARMY HIGH COMMAND.** The highest echelon under the Army High Command consists of three Army Groups. One Army Group consists of a Replacement Training Army and the framework and staffs for a Peoples Militia. The other two Army Groups are organized as shown in figure 7.

27. **ORGANIZATION OF ARMY GROUPS.** Each Army Group has two to four Armies. Organic in the Army Group are various staff units dealing with administrative and operational matters within its territory.

28. ORGANIZATION OF ARMIES. Each Army in the field has two to five Corps. There are four types of Corps: Infantry, Mechanized, Armored, and Airborne. Organic Army troops are various police units, supply staffs, a field post office, and a propaganda company.

29. ORGANIZATION OF CORPS. Each Corps in the field has two to five divisions of the following types: Infantry (light, motorized, standard), Fusilier, Armored, Airborne, Mechanized, Cavalry, and Artillery. Organic troops include Engineers, Medical troops, Air Observation Squadron, Survey Regiments, and Machine Gun Battalions. An Armored Corps has four regiments of medium (SP) Artillery.

Section III. ARMY GROUPS AND ARMIES

30. STAFF ORGANIZATION. Army Groups and Armies have identical staff structure; sections are proportionally larger at army group level (fig. 8).

31. GENERAL HEADQUARTERS TROOPS. General Headquarters troops that may be attached to army groups and armies include—

a. Armored troops.

- Heavy tank battalions
- Flame thrower battalions
- Heavy antitank battalions
- Heavy assault gun battalions
- Reconnaissance battalions
- Armored trains
- Tank repair battalions

b. Infantry.

- Raiding battalions
- Machine gun battalions
- Ski infantry battalions
- Fortress battalions

c. Artillery.

- Heavy and super-heavy artillery battalions
- Self-propelled battalions
- Antiaircraft battalions
- Observation battalions
- Railway artillery battalions
- Survey and mapping battalions
- Meteorological platoons
- Observation balloon batteries
- Rocket battalions
- Mortar brigades

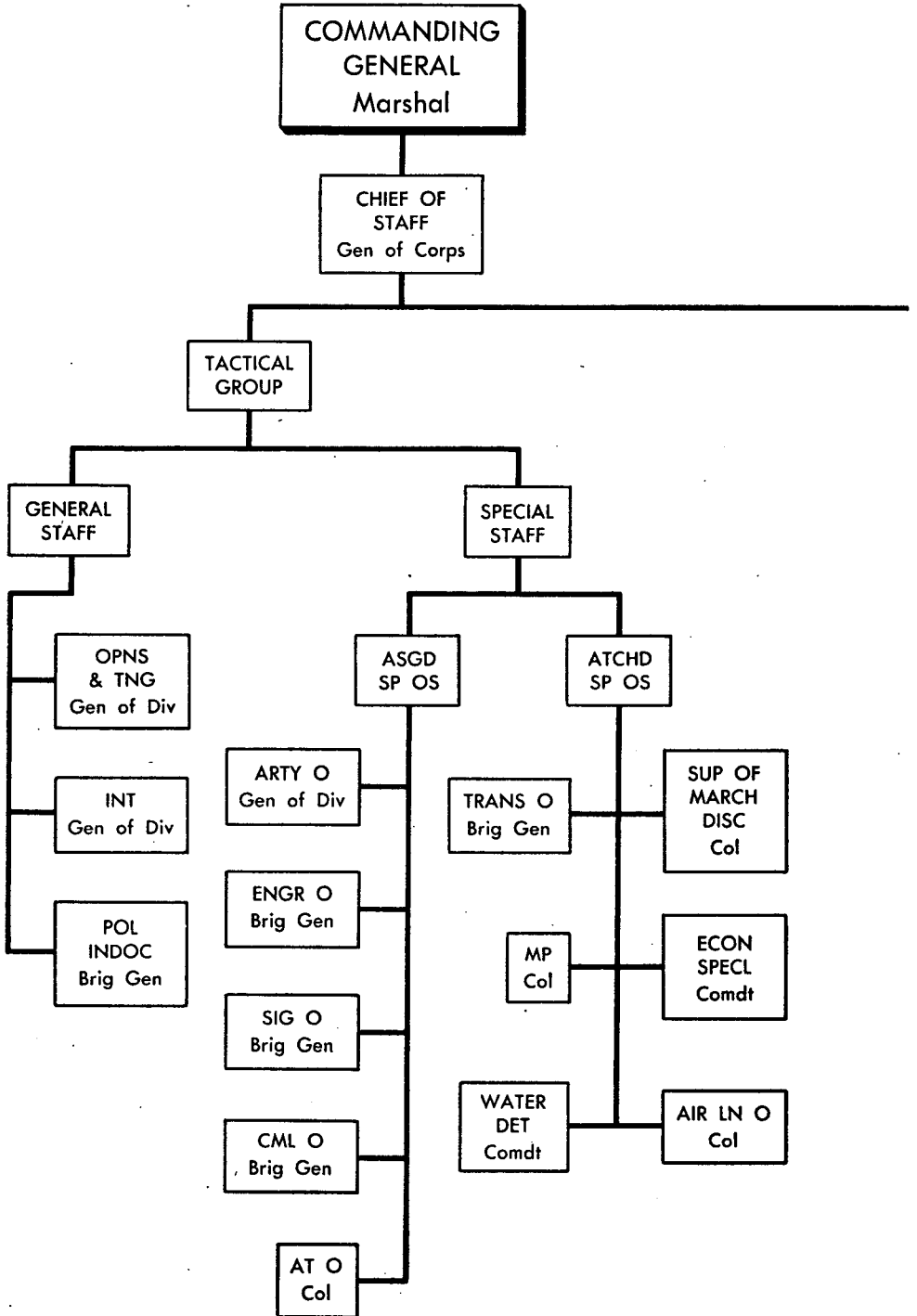

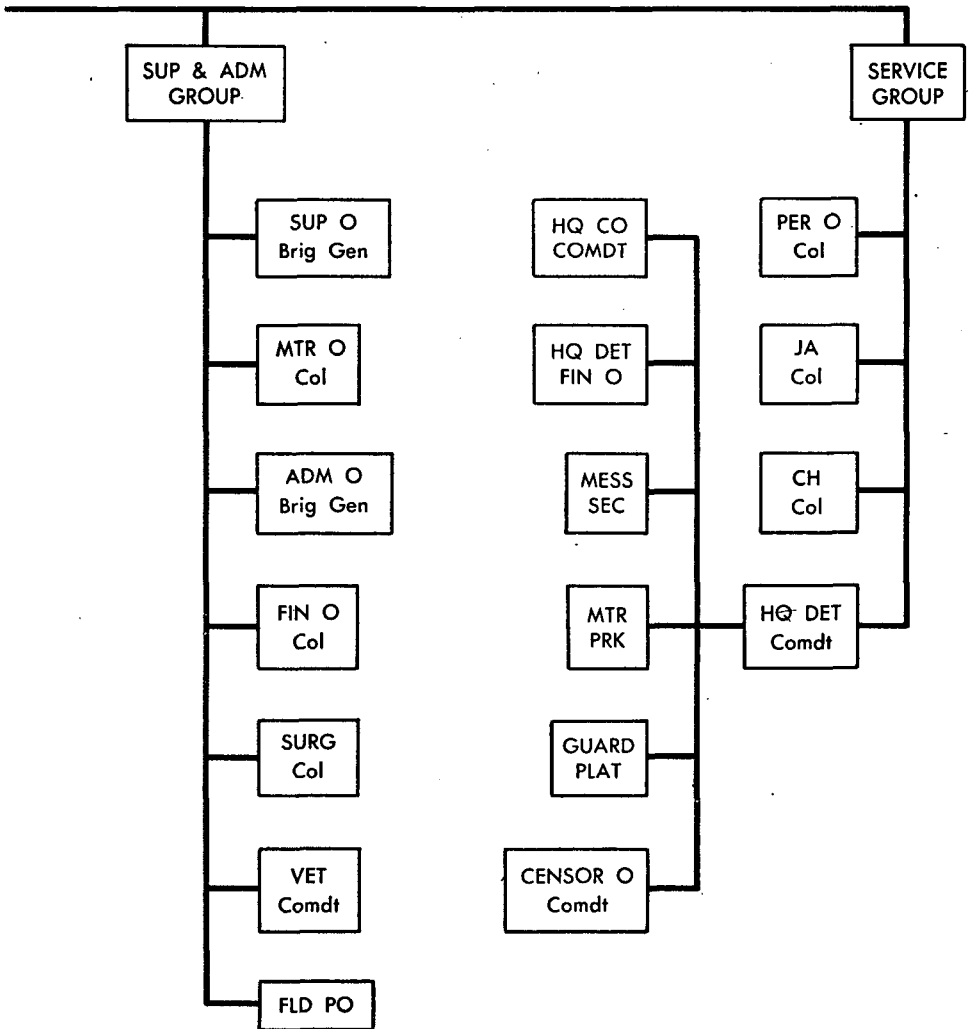

Figure 8. Army group staff organization.

d. Engineers.

- Engineer battalions
- Bridge construction battalions
- Road construction battalions
- Prisoner of war labor battalions
- Mine detection companies
- Demolition companies

e. Chemical troops.

- Smoke battalions
- Decontamination battalions
- Flame throwing battalions
- Bacteriological companies

f. Signal units.

- Signal battalions or regiments
- Radio intercept battalions

g. Miscellaneous.

- Motor transport battalions
- Supply column battalions
- Motor maintenance and repair units
- Medical units
- Veterinary units
- Propaganda units

Section IV. CORPS

32. CORPS ORGANIZATION. Corps organization generally parallels that in the US Army. It consists of a corps headquarters (fig. 9), normal organic units, and two or more divisions, though seldom exceeding five. Corps when in the homeland are merely skeleton headquarters.

33. CORPS TROOPS. a. Standard. The following troops are normally organic to each corps in the field; however, considerable variation exists between individual corps depending upon their mission and terrain:

(1) *Corps headquarters.*

- Headquarters defense company
- Headquarters car company

(2) *Artillery.*

- Air observation post squadron
- Air observation post flight
- Survey regiment

(3) *Engineer.* One regiment consisting of a headquarters, three companies, and one service company. The strength of the field company is about 250 and performs normal engineer work. The service company contains a supply section, a repair shop, and bridge section.

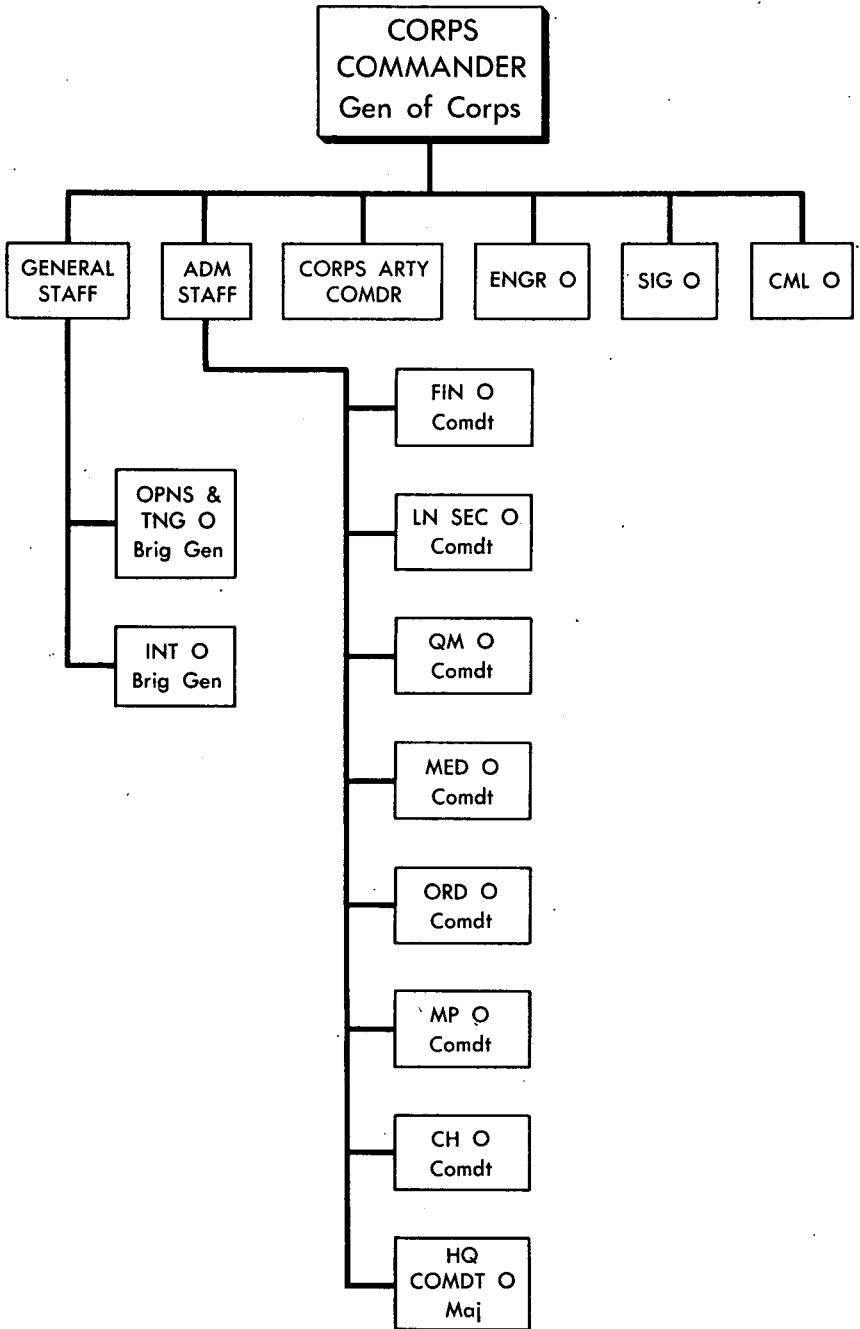

Figure 9. Corps staff organization.

(4) *Signal*. One signal battalion consisting of a headquarters and two companies. One is a construction company; the other radio.

(5) *Machine gun*. One MG battalion consisting of a headquarters and three HMG companies. Each company has three platoons of four guns each.

(6) *Miscellaneous*. Normal medical, ordnance, and finance.

b. Armored. The armored corps contains the above components, though many are armored, such as armored engineers and armored signal units. In addition, more and heavier bridging units are present, as well as increased ordnance personnel. A large increase in artillery (SP) is also usually found.

Section V. PRINCIPLES IN UNIT ORGANIZATION AND EQUIPMENT

34. GENERAL. The Aggressor Army, like the United States Army, believes in uniform organization for standard units up to and including companies, troops, and batteries. These are either combined as components of battalions, regiments, brigades, and divisions, or temporarily grouped in varying combinations as components of task forces or combat groups. As shown in figure 7, page 52, the Aggressor Army in the field is organized into army groups, armies, corps, and divisions. Divisions are the largest units in the Aggressor Army known to have a prescribed organization, and those divisions which function as tactical units are normally the smallest formations which include units of various arms and services resulting in operational self-sufficiency. There are tables of organization and equipment published for all units of divisional and smaller size, down to and including sections or squads. The figures in section VII showing the organization, strength, and equipment of various Aggressor units are based on these tables of organization and equipment, but in the field the strength of any unit will vary in accordance with its specific mission and local conditions. However, even in the greatest deviation from the tables of organization and equipment, the basic pattern will be clearly recognizable. GHQ and corps troops are allotted temporarily to lower echelons in a flexible manner in accordance with operational plans or local tactical necessities. The various types of Aggressor Army divisions and their component units, and such GHQ and corps units as have been identified are shown in section VII.

Section VI. DIVISIONS

35. DIVISION ORGANIZATION. a. The divisional structure is undergoing various modifications, and at present there appear to be eight different types of divisions. They are as follows:

- Infantry divisions (*standard*)
- Light divisions (*infantry*)
- Motorized divisions (*infantry*) and
fusilier divisions (*elite troops*)
- Airborne divisions
- Armored divisions
- Mechanized divisions
- Cavalry divisions
- Artillery divisions

The standard, light, and motorized infantry divisions are all considered as infantry divisions and have identical designations in Aggressor terminology; for order of battle purposes, however, they are referred to as infantry, light, and motorized divisions, respectively. The fusilier divisions are classified separately, although identical in structure to the motorized divisions. A brief discussion of these divisions follows, but they are discussed more fully and shown in detail in the organizational charts in the next section.

b. The infantry is the senior and preferred arm. It has a higher pay scale, receives special rations, and has certain other privileges. Men are carefully selected for physical stamina.

c. Three types of infantry divisions are presently in existence: standard, light, and motorized. Fusilier divisions are identical in structure to the motorized. They (and to a lesser degree the paratroopers) are an elite corps designed for important assault missions and generally do not remain long in the line. Motorized divisions are better equipped and trained than the foot divisions and are normally maintained at full strength. The light division (brigade type) is light in artillery; however, the infantry battalion is larger and capable of more independent action than the standard battalion. It is believed, however, that this unit is not intended so much for assault action, but rather for garrison, police, and anti-guerrilla assignments.

d. The mechanized and armored divisions vary primarily in the amount of organic infantry. The former is heavy in infantry, while the latter is relatively light.

e. The general practice in the Aggressor Army is to number the companies rather than to letter them.



36. **STAFF ORGANIZATION.** The staff organization of the division headquarters is given in figure 10.

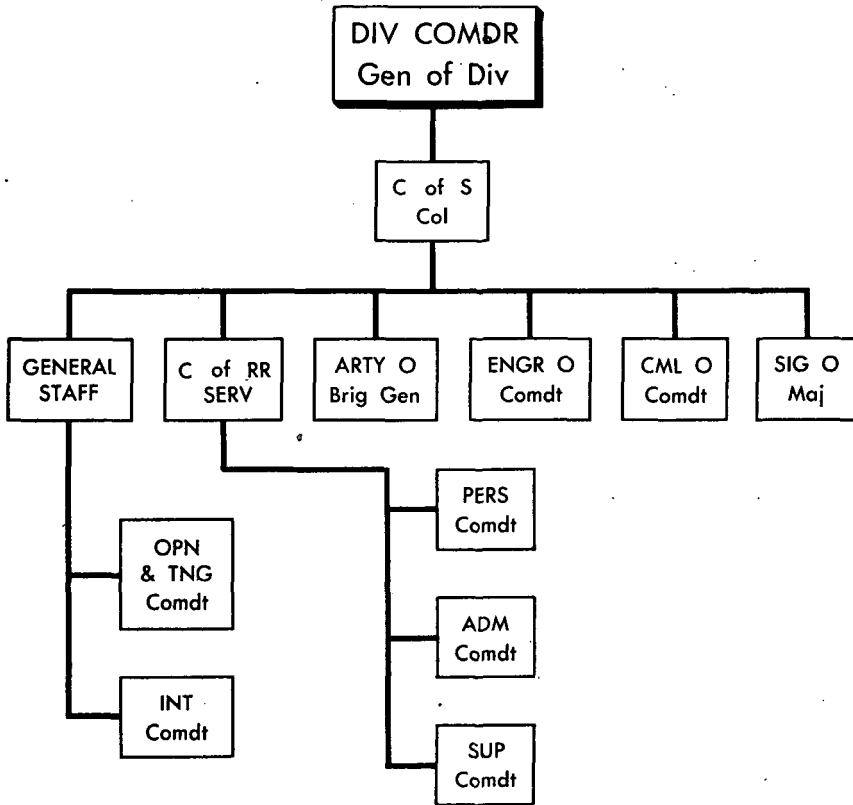

Figure 10. Division staff organization.

37. **TYPES OF DIVISIONS.** a. **Infantry divisions.** Despite the important role which has been played by specialized branches of the Aggressor Army, the infantry has been and remains today the foundation for most Aggressor operations. There are three types of infantry divisions: standard, light, and motorized. Some of the motorized divisions have been given the distinction of an elite organization and have been redesignated as fusilier divisions. They contain the finest troops in the Aggressor Army.

(1) *Standard infantry division.* The standard infantry division (fig. 11) consists of three infantry regiments (fig. 12) of three battalions each, an artillery brigade (fig. 18) containing two artillery regiments and one mortar regiment, an antitank regiment, an antiaircraft regiment, a reconnaissance company, an engineer company, a signal company (fig. 22), a headquarters company, and a service battalion (fig. 45). Its T/O strength is approximately 14,466 officers and men.

(2) *Light division.* The light division (fig. 22) is so named because of the smallness of its artillery strength, there being a total of only eight batteries (75-mm guns) in the entire division; they are distributed on the basis of one battery to each of the division's eight infantry battalions (fig. 23). These infantry battalions are much stronger than those in the infantry regiments of the standard and motorized divisions, having approximately 1,304 men in comparison with the approximate 838 of the standard infantry battalion. Another feature of the light division is that it has no reconnaissance elements or service battalion or company such as is found in all other types of divisions. Instead it contains a horse-drawn transportation battalion, a medical battalion, and a veterinary platoon. The eight infantry battalions referred to above are organized into two brigades, and the only other organic components of the light division are an engineer company, a signal company, and a headquarters company. Its T/O strength is approximately 12,497.

(3) *Motorized and fusilier divisions.* The fusilier division, as explained above, is actually a motorized division (fig. 21) which has been given an honorary title; its infantry regiments are called fusilier regiments, but otherwise its units have no special designation. This type of division contains three motorized infantry regiments of the standard type (fig. 12), two tank battalions, a truck-drawn artillery regiment (fig. 32), an antitank regiment, a rocket battalion (fig. 41), a reconnaissance company, an engineer company (fig. 11), a signal company (fig. 22), a headquarters company, and a service battalion (fig. 46). The T/O strength of the motorized and fusilier divisions is approximately 13,365.

b. Airborne division. This is actually an infantry type division, but is listed separately because of its special organization. Like the fusilier divisions, these divisions were originally infantry divisions, but later redesignated and placed in the elite class. In the case of the airborne division (fig. 24), however, it was necessary to carry out extensive reorganization in accordance with its intended mission. There are no regiments in the airborne division; instead it has two brigades each of which is organized along divisional lines, containing all necessary arms and services to make it capable of fighting as an independent unit. Thus, it is found that the component parts of the airborne division are only the two airborne brigades, one artillery battalion (fig. 25), a headquarters company, and a medical battalion (fig. 50) similar to the one in the light division. Its T/O strength is approximately 14,148. Each brigade, however, contains the following: four parachute infantry battalions, one tank battalion (fig. 29), one artillery battalion, one antitank battalion, one antiaircraft battalion, a reconnaissance company (fig. 11), an engineer company (fig. 11), a signal company (fig. 22), a headquarters company, and a service battalion (fig. 46). Brigade T/O strength approximately 6,372.

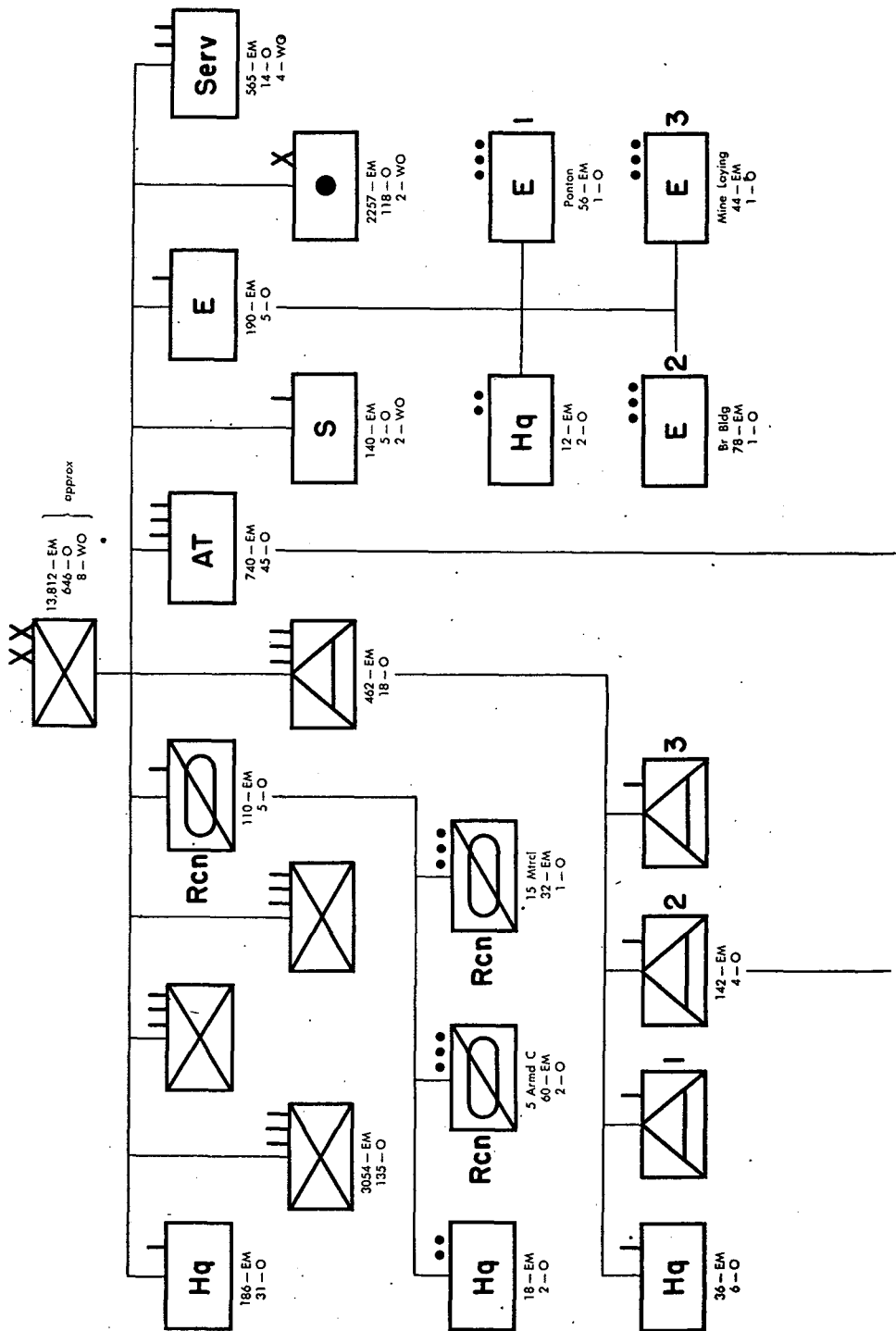

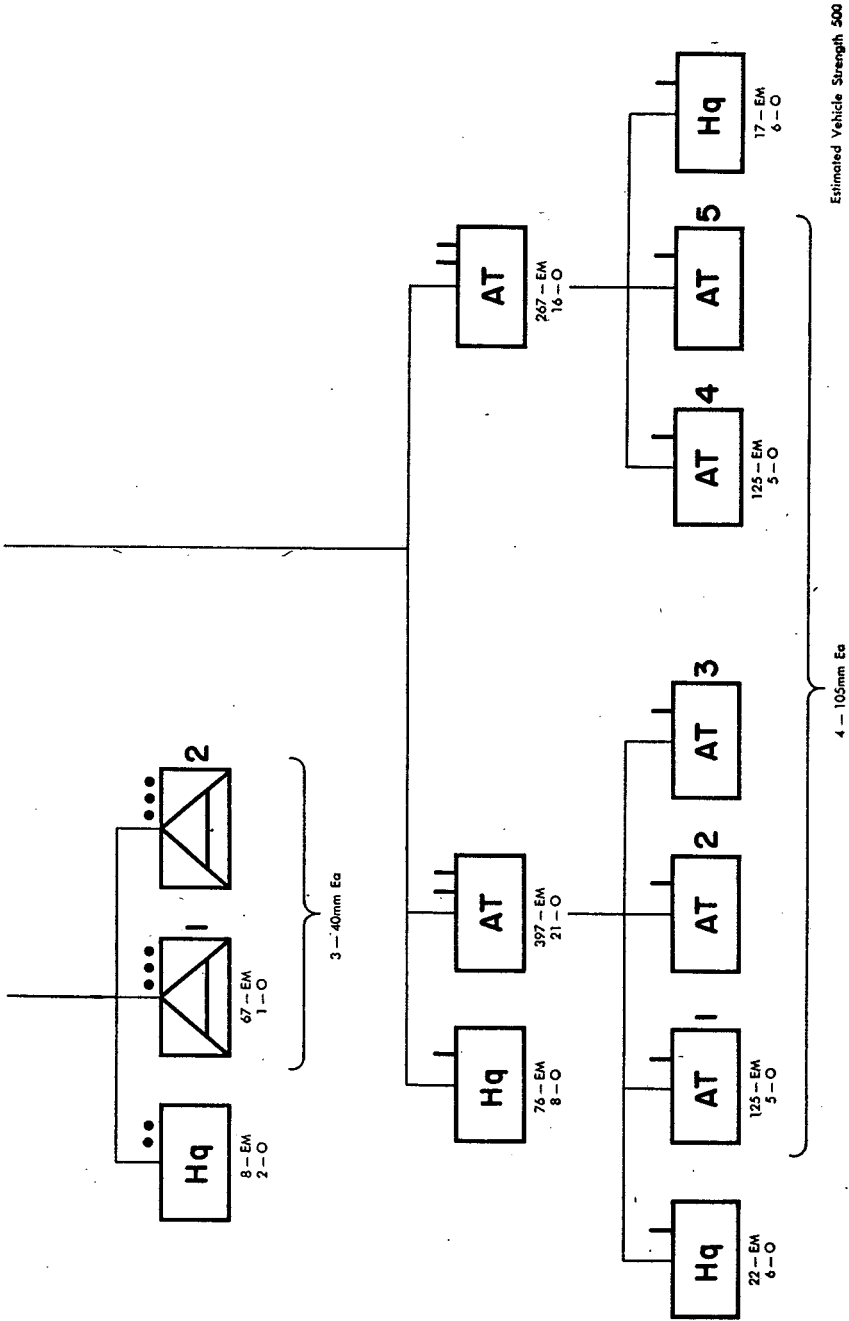
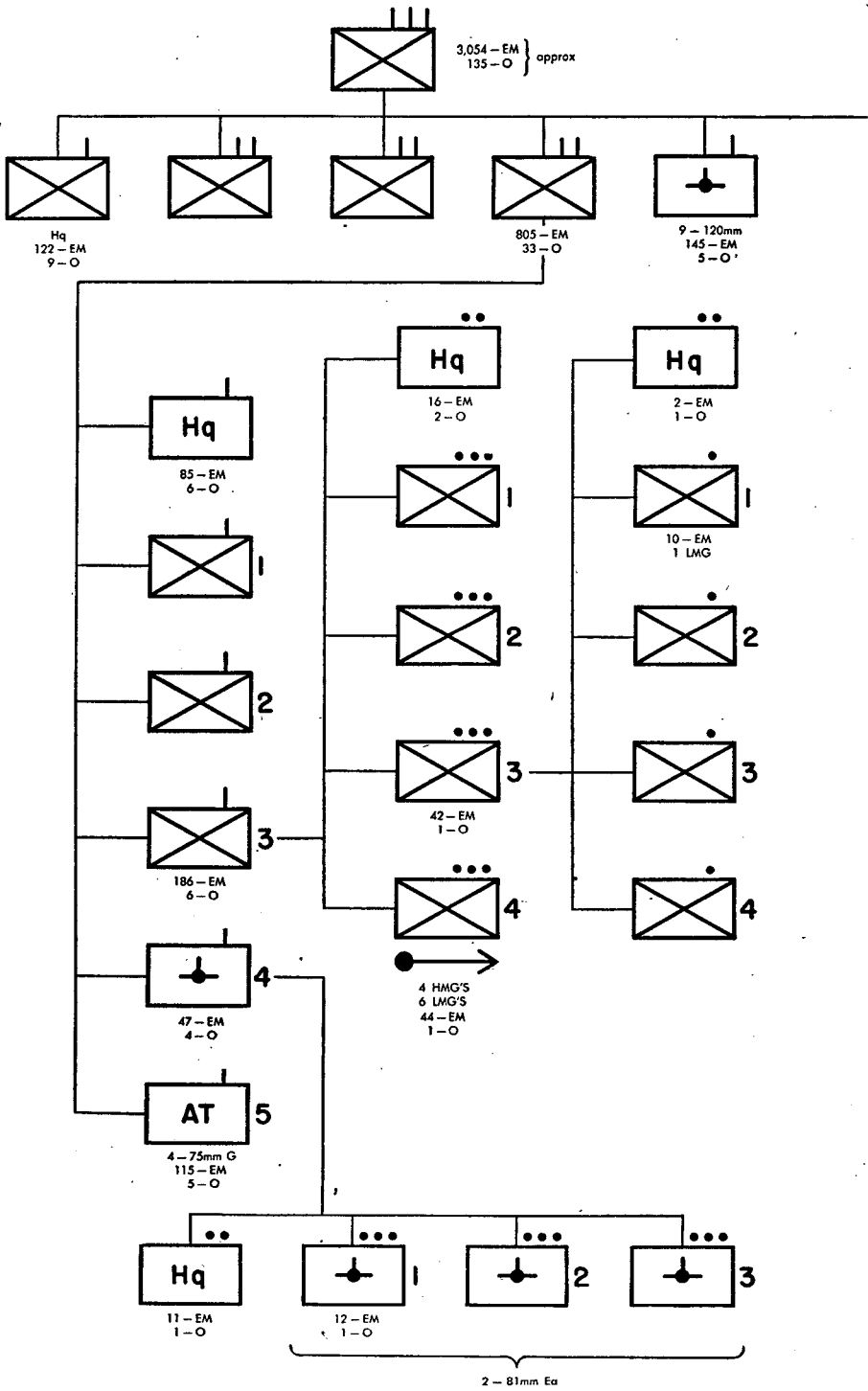

Figure 11. Standard infantry division.



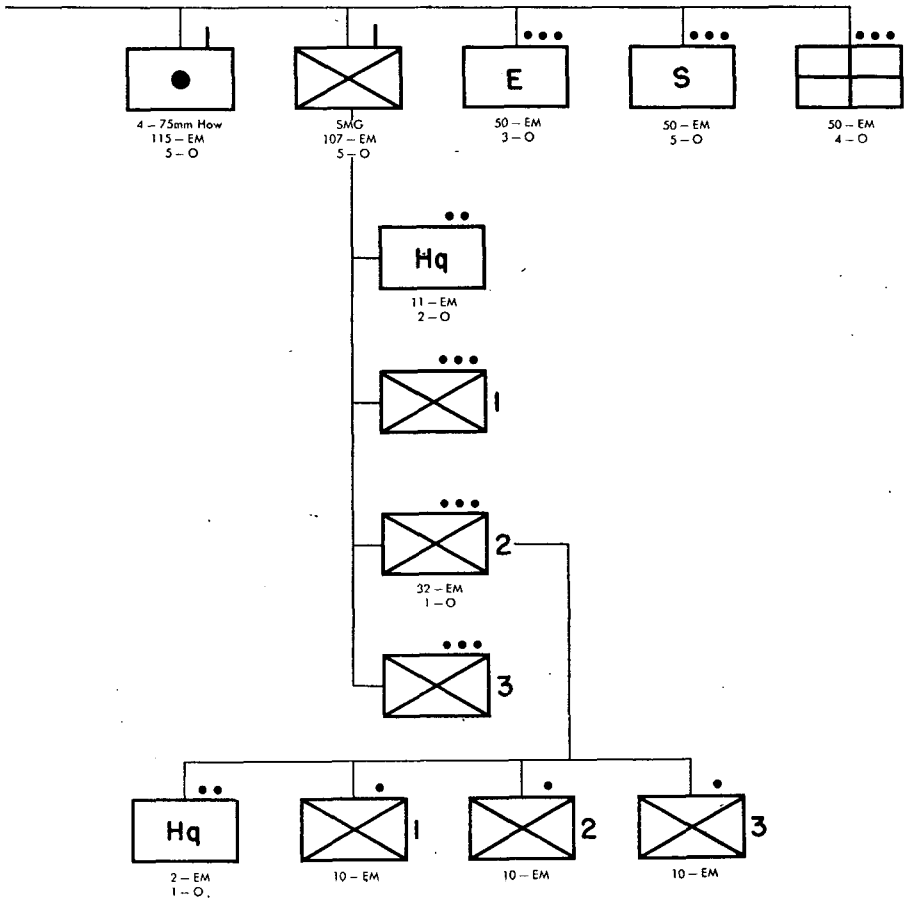

Figure 12. Standard infantry regiment.

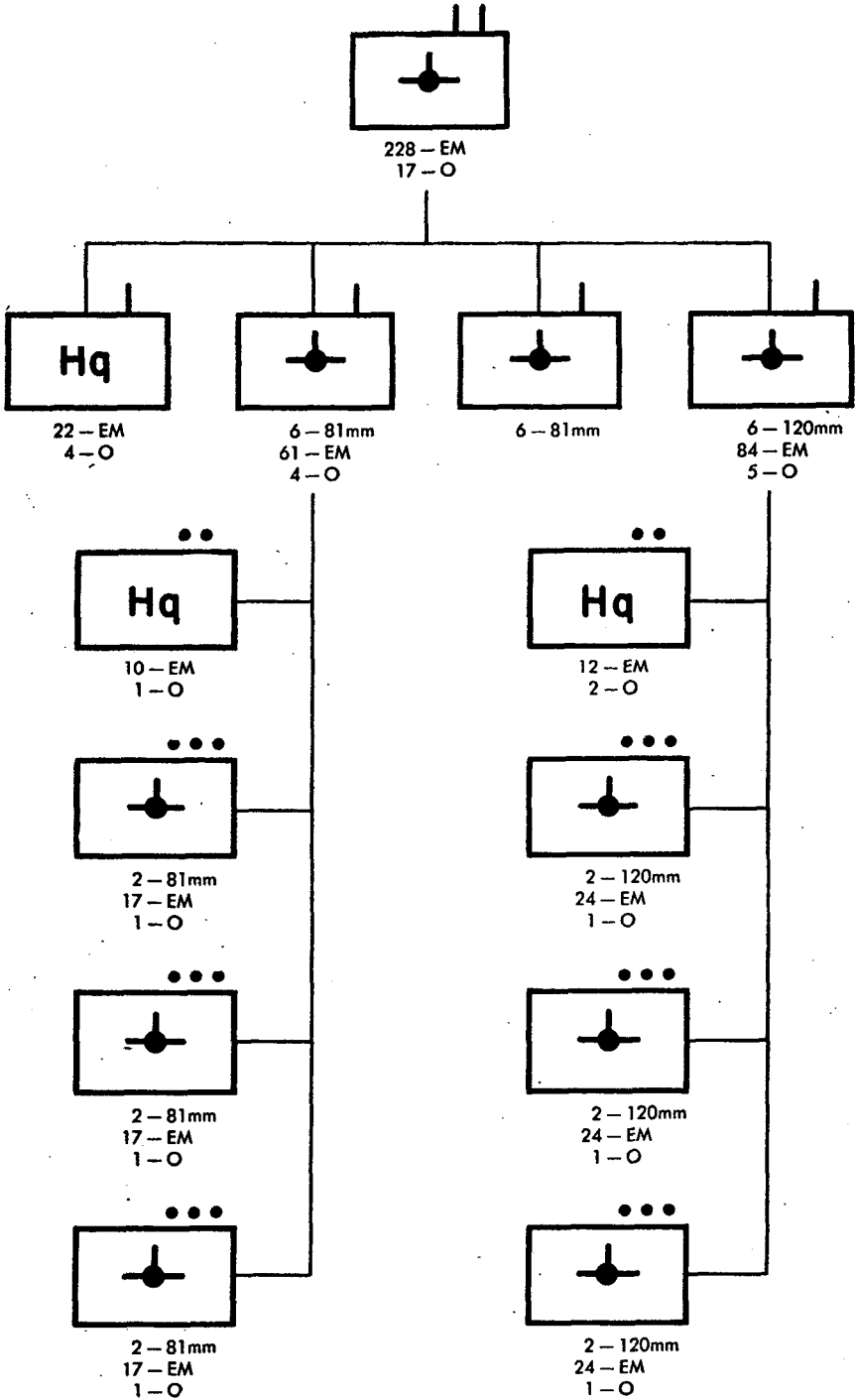

Figure 13. Mortar battalion, mechanized infantry regiment.

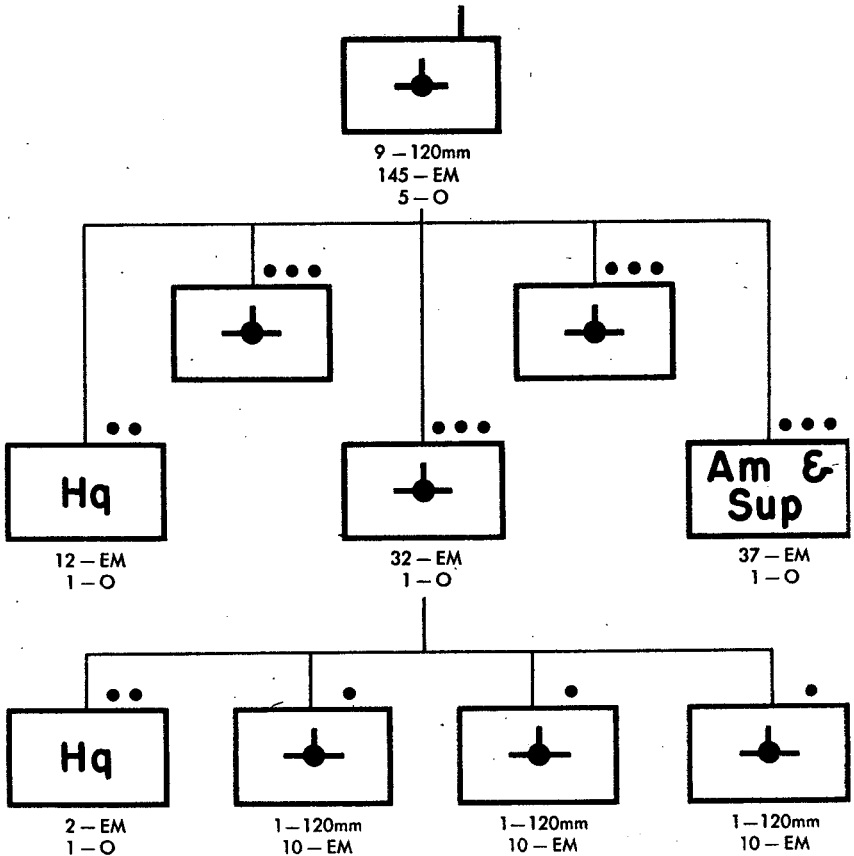

Figure 14. Mortar company, infantry regiment.

c. **Armored and mechanized divisions.** Every Aggressor large-scale attack and counterattack in the California campaign was spearheaded by armored and mechanized divisions, working in cooperation with the motorized and fusilier divisions. Large numbers of tanks were concentrated at the breakthrough point, supported by tremendous artillery strength. These thrusting attacks account for the great importance the armored and mechanized divisions play within the Aggressor Army, and for the especially well-trained personnel and newest types of weapons and equipment found in these divisions. Both of these divisions are of the armored type, but the mechanized division (fig. 26) is much stronger in infantry. This accounts for the big difference in T/O strength, 16,197 in the mechanized division and only 6,532 in the armored division (fig. 29). Each of the three tank regiments of the armored division has an armored infantry battalion, this being the only infantry element in the entire division. The mechanized division, however, contains three complete mechanized infantry regiments. Although it contains only two tank

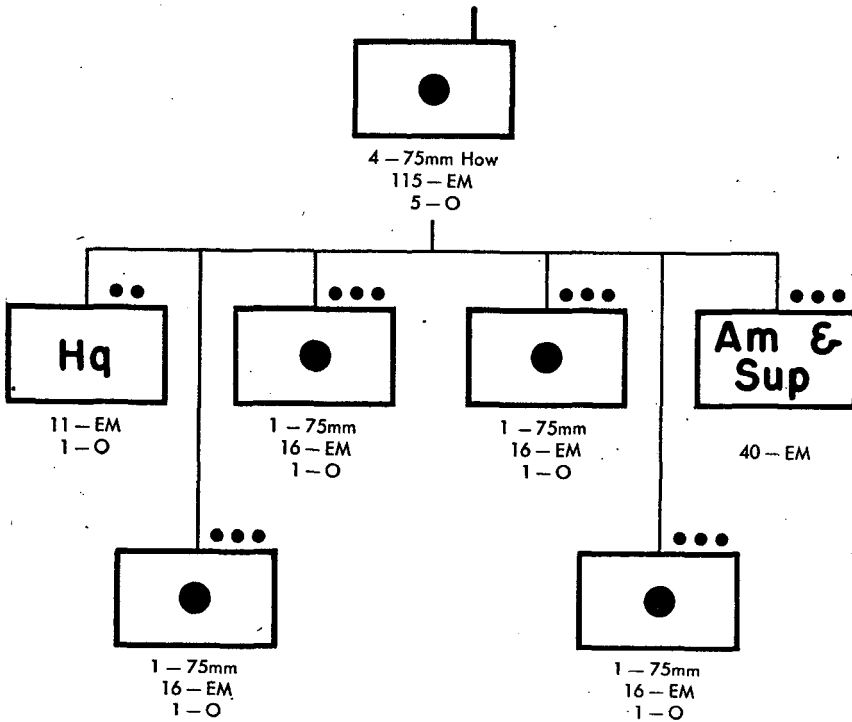

Figure 15. 75-mm. howitzer battery, infantry regiment.

regiments as compared to three in the armored division, the mechanized division has nine tank battalions while the armored division has only six. This is due to the fact that the third battalion in each of the armored division's tank regiments is an infantry battalion, and each of the mechanized division's three infantry regiments contains an additional tank battalion.

(1) *Armored division* (fig. 29). Consists of three tank regiments each containing two tank battalions and an armored infantry battalion, two self-propelled artillery regiments (fig. 33), one mortar regiment (fig. 18), one armored reconnaissance battalion, an engineer company (fig. 11), a signal company (fig. 22), a headquarters company, and a service company (fig. 49). T/O strength approximately 6,532.

(2) *Mechanized division* (fig. 26). (a) Consists of two tank regiments each containing three tank battalions, three mechanized infantry regiments, one self-propelled artillery regiment (fig. 33), one truck-drawn artillery regiment (fig. 32), one mortar regiment (fig. 18), one rocket battalion (fig. 41), one antitank regiment (fig. 11), one antiaircraft regiment (fig. 11), an armored reconnaissance battalion, an engineer company (fig. 11), a signal company (fig. 22), a headquarters company, and a service company (fig. 49). T/O strength approximately 16,197.

(b) The mechanized infantry regiment is organized along divisional lines to make it a self-sufficient tactical unit. It consists of two armored infantry battalions (fig. 29), one tank battalion, two mortar battalions, a reconnaissance company (fig. 11), a headquarters company, an engineer platoon (fig. 42), a signal platoon (fig. 44), and a service battalion (fig. 46). T/O strength approximately 3,216.

d. **Cavalry division.** The only three identified cavalry divisions (fig. 31) in the Aggressor Army are well trained, well equipped, and of high fighting efficiency. Each cavalry division contains a tank regiment similar to the one found in the armored division (fig. 29), and its three cavalry regiments are very strong in machine guns and heavy weapons. These cavalry divisions are GHQ units and generally function as corps troops, being used in screening operations to protect the flanks and in mountainous or difficult terrain. They are often used in conjunction with an armored attack as a cavalry screen in a protective mission, inasmuch as they contain a tank regiment and all the necessary arms and services to make them tactically self-sufficient; the tank regiment contains an armored infantry battalion. The cavalry division consists of three cavalry regiments, a tank regiment (fig. 29), an artillery regiment (fig. 18), an antiaircraft battery (fig. 11), a reconnaissance company, an engineer company, a signal company (fig. 22), a headquarters company, and a service battalion (fig. 46). Its T/O strength is approximately 6,972.

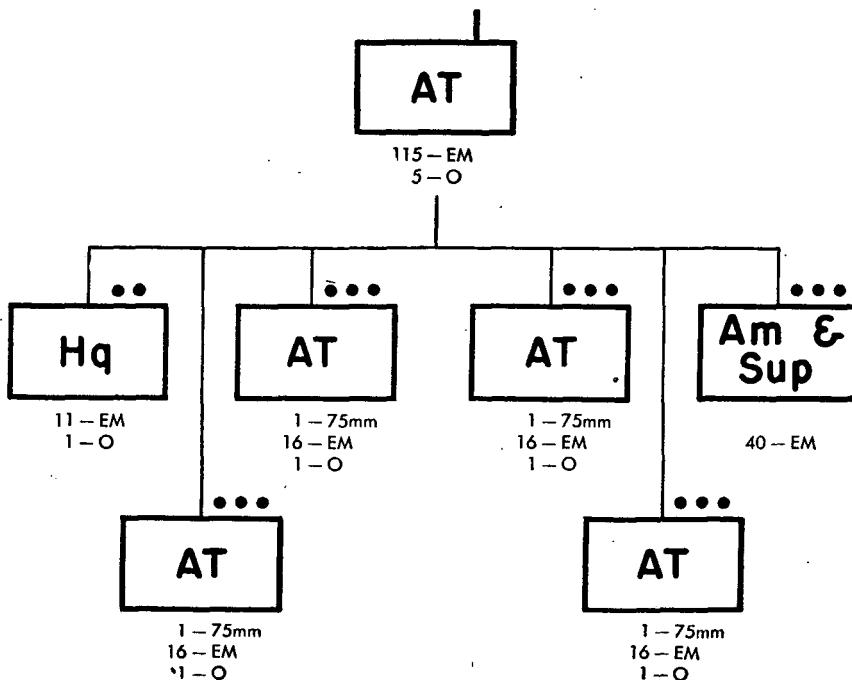

Figure 16. Antitank company, infantry battalion.

e. Artillery division. The artillery division (fig. 30) is in keeping with the Aggressor doctrine of heavy concentration of artillery at breakthrough points. Like the cavalry divisions, they are also GHQ units, and during the California campaign one was attached to each corps for overall artillery support. It consists of three artillery brigades of three regiments each, one mortar brigade of three regiments, a signal battalion (fig. 43), a survey battalion, a headquarters company, and a service battalion (fig. 47). The artillery brigades have the following matériel: one brigade has 72 75-mm guns; one has 96 120-mm howitzers; and the third has 54 150-mm gun/howitzers. The mortar brigade has 108 120-mm mortars. T/O strength is approximately 13,546.

Section VII. UNIT ORGANIZATIONAL CHARTS

38. GENERAL. a. Section VIII contains all the known unit organizational charts of the Aggressor Army. Supplementary breakdown charts usually follow each divisional chart, but where component units have identical organization in two or more types of division, they are generally broken down on one divisional chart only and are shown only once in the supplementary charts. Where GHQ, Corps troops, or divisional component units have identical organization, they are shown on only one chart. There are forty-one charts in all, designated as figures 11 to 51, inclusive.

b. Figures 11 to 33 cover divisions and most of the divisional component units of the combat arms; figures 34 to 41 cover all the known GHQ and Corps troops combat units; figures 42 to 44 cover engineer and signal units; figures 45 to 51 cover service troops.

c. Following is a list of charts shown in Section VIII.

<i>Figure No.</i>	<i>Title of chart</i>	<i>Page No.</i>
11	Standard infantry division	62
12	Standard infantry regiment	64
13	Mortar battalion, mechanized infantry regiment	66
14	Mortar company, infantry regiment	67
15	75-mm howitzer battery, infantry regiment	68
16	Antitank company, infantry battalion	69
17	Machine gun platoon, rifle company	73
18	Artillery brigade	74
19	120-mm howitzer battery, artillery brigade	76
20	120-mm mortar battery, artillery brigade	77
21	Motorized division	78
22	Light division	80

<i>Figure No.</i>	<i>Title of chart</i>	<i>Page No.</i>
23	Infantry battalion, light division	82
24	Airborne division	84
25	Artillery battalion, airborne division	86
26	Mechanized division	88
27	Machine gun company, armored and mechanized infantry battalions	90
28	Tank borne infantry company, armored infantry bat- talion	91
29	Armored division	92
30	Artillery division	94
31	Cavalry division	96
32	Artillery regiment (truck drawn), motorized and mech- anized divisions	98
33	Artillery regiment (SP)	99
34	Survey regiment (corps troops)	100
35	Air observation post squadron	103
36	Ski battalion	104
37	Flame thrower battalion	106
38	Chemical warfare service regiment (smoke).....	108
39	Tank destroyer brigade	110
40	57-mm tank destroyer company, tank destroyer brigade	112
41	Rocket battalion	116
42	Engineer platoon, infantry regiments and armored in- fantry battalions	118
43	Signal battalion	119
44	Signal platoon, infantry regiments and parachute infan- try battalion	120
45	Service battalion, standard infantry division.....	122
46	Service battalion for the airborne brigade, motorized division, mechanized infantry regiment, or cavalry division	123
47	Service battalion, artillery division	124
48	Service battery, artillery brigade	125
49	Service company, mechanized and armored divisions...	126
50	Medical battalion, light and airborne divisions.....	128
51	Medical platoon, infantry regiment	129

Section VIII. COMBAT TROOPS

39. GENERAL. This section contains a list and brief description of the more important types of combat units in the Aggressor Army of the size of brigade and lower with particulars on their organization. They are arranged according to branch of service, divided into divisional units (integral parts of divisions) and non-divisional units. Reconnaissance troops are not a separate branch of service, but belong instead to the branch controlling the unit in which they are found. For coordinating their training, however, all reconnaissance units are under the supervision of the Chief of Reconnaissance Troops, working in conjunction with the chiefs of branches concerned. Non-divisional units consist of GHQ troops (units held in the GHQ pool from which they are allotted to army groups, armies, and corps) and Corps troops (units normally organic to a corps headquarters); both GHQ and Corps troops can be sub-allotted temporarily to divisions for specific operations.

40. INFANTRY. This branch includes all the infantry-type units in the Aggressor Army, including those in the fusilier, airborne, armored, and mechanized divisions. It also includes all the infantry units of the GHQ and Corps troops, such as ski battalions and machine gun battalions. A complete list containing detailed descriptions follows.

a. Divisional infantry units. (1) *Infantry brigades.* Found only in the light division (fig. 22) and the airborne division (fig. 24). There are no regiments in either type of brigade, the next subordinate unit being the battalion.

(a) *Infantry brigade* (fig. 22). Two in each light division. Consists of four infantry battalions (fig. 23) and a headquarters company. T/O strength approximately 5,383.

(b) *Airborne brigade* (fig. 24). Two in each airborne division. Each airborne brigade is organized along divisional lines, being a complete tactical unit in itself. Consists of four parachute infantry battalions, one tank battalion (fig. 29), one artillery battalion, one antitank battalion, one antiaircraft battalion, a reconnaissance company (fig. 11), an engineer company (fig. 11), a signal company (fig. 22), a headquarters company, and a service battalion (fig. 46). T/O strength approximately 6,372.

(2) *Infantry regiments.* Found in infantry divisions (fig. 11), motorized and fusilier divisions (fig. 21), and mechanized divisions (fig. 26). There are two types: standard and mechanized. Both types contain all the necessary arms and services to make them tactically self-sufficient.

(a) *Standard infantry regiment* (fig. 12). Three in each infantry, motorized, and fusilier division. Those of the motorized and fusilier divisions are motorized, the fusilier infantry regiment being designated as *Fusilier Regiment*. Consists of three infantry battalions, a 120-mm

mortar company (fig. 14), a 75-mm howitzer battery (fig. 15), a sub-machine gun company, a headquarters company, an engineer platoon (fig. 42), a signal platoon (fig. 44), and a medical platoon (fig. 51). T/O strength approximately 3,189.

(b) *Mechanized infantry regiment* (fig. 26). Three in each mechanized division. Consists of two armored infantry battalions (fig. 29), one tank battalion, two mixed mortar battalions (fig. 13), a reconnaissance company (fig. 11), a headquarters company, an engineer platoon (fig. 42), a signal platoon (fig. 44), and a service battalion (fig. 46). T/O strength approximately 3,216.

(3) *Infantry battalions*. Found in all types of divisions, except artillery. There are four different kinds: standard, light, airborne, and armored.

(a) *Standard infantry battalion* (fig. 12). Found in the infantry regiments of the infantry division (fig. 11), and in the motorized and fusilier divisions (fig. 21). There are three battalions in each regiment, those in the motorized and fusilier divisions being motorized. Consists of three rifle companies, an 81-mm mortar company, a 75-mm antitank company (fig. 16), and a headquarters company. T/O strength approximately 838.

(b) *Light battalion* (fig. 23). Four in each infantry brigade of the

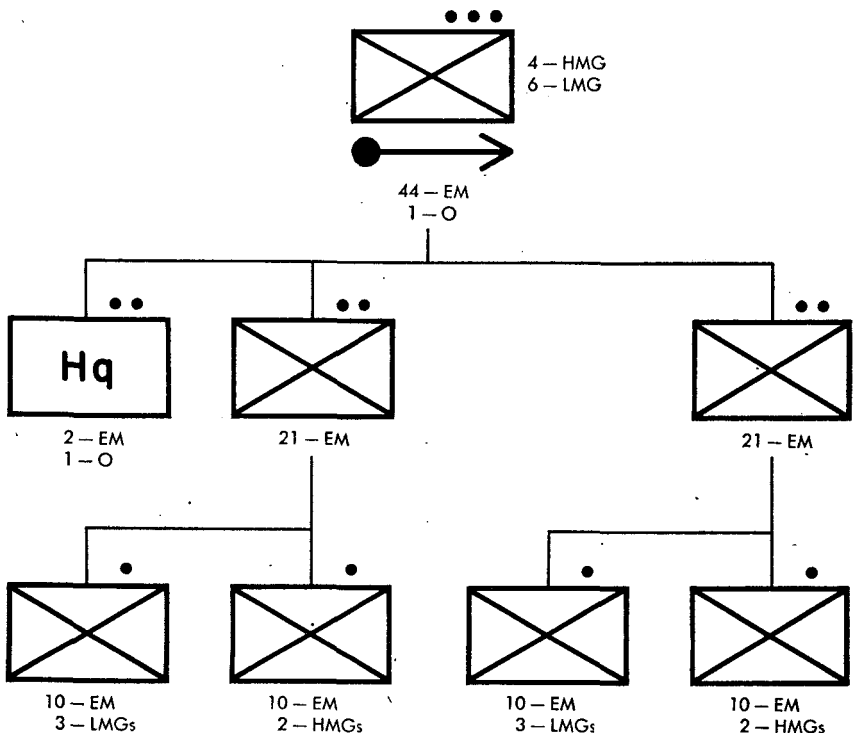
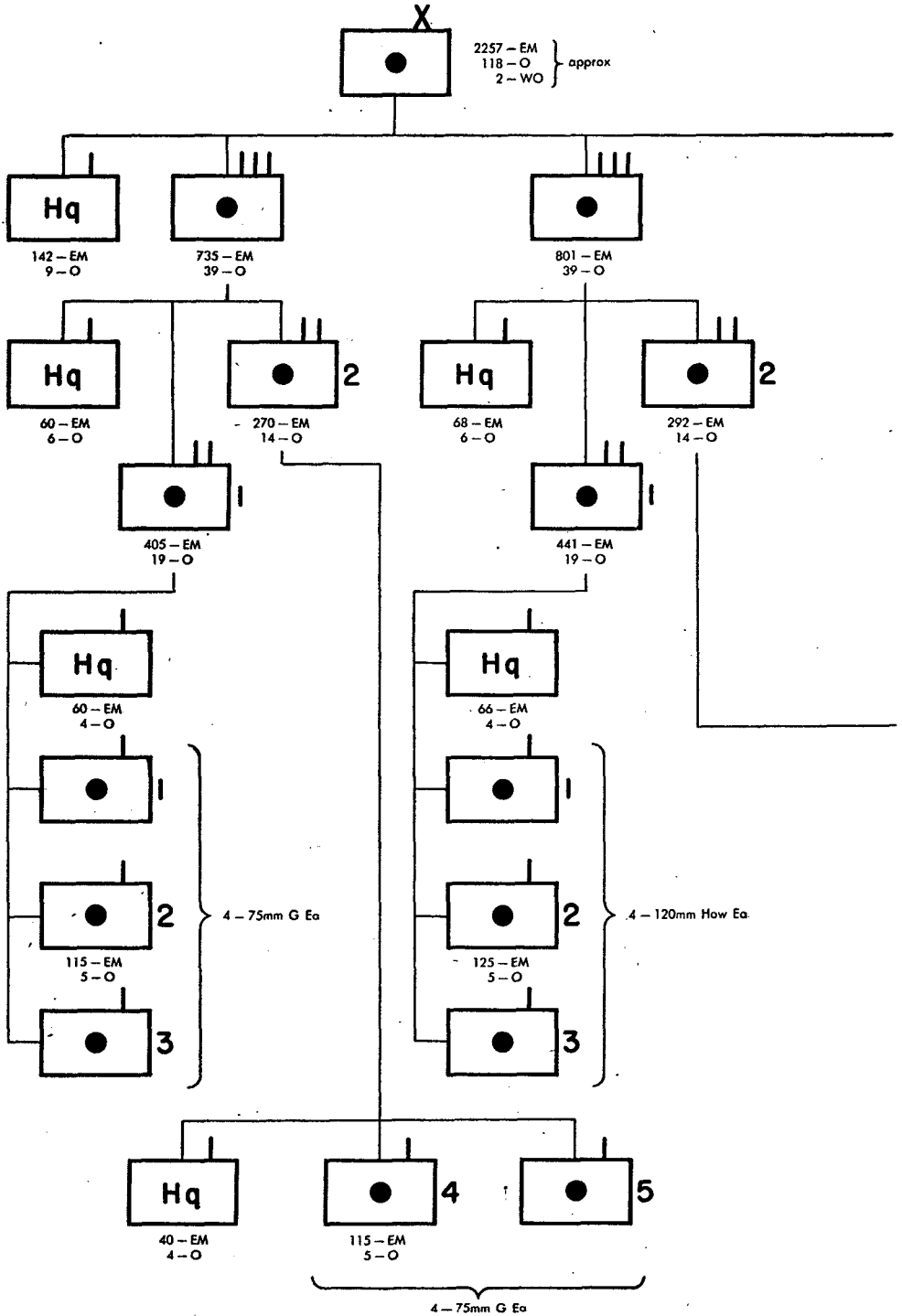

Figure 17. Machine gun platoon, rifle company.



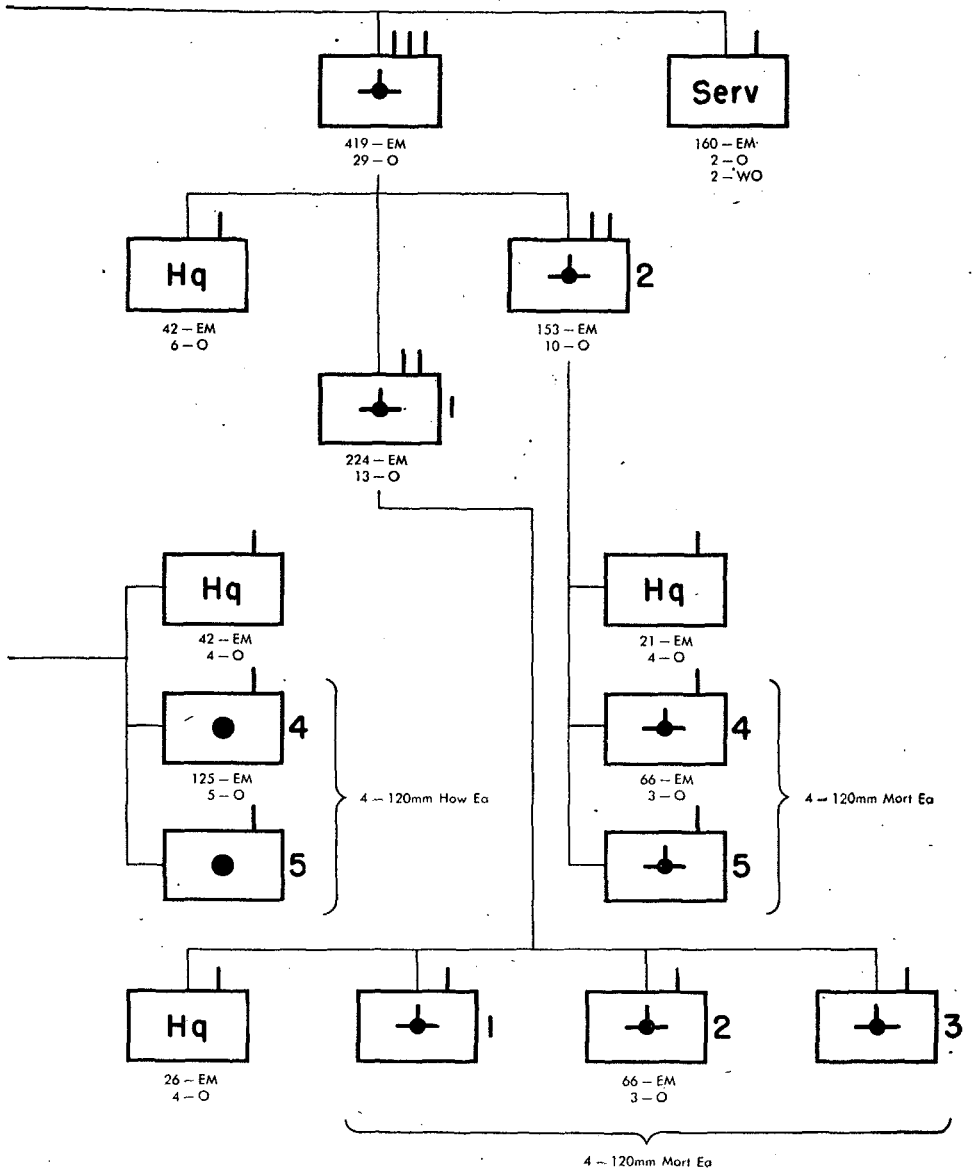

Figure 18. Artillery brigade.

light division (fig. 22). Consists of five rifle companies, one machine gun company, a 75-mm gun battery, and a headquarters company. T/O strength approximately 1,304.

(c) *Parachute infantry battalion* (fig. 24). Four in each airborne brigade. Consists of four rifle companies, a 50-mm mortar company, a headquarters company, a signal platoon (fig. 44), and a medical platoon. T/O strength approximately 1,012.

(d) *Armored infantry battalion* (fig. 29). One in each of the tank regiments of the armored and cavalry divisions (fig. 31), and two in each of the mechanized infantry regiments (fig. 26) of the mechanized divisions. Consists of one tank borne infantry company (fig. 28), one machine gun company (fig. 27), one submachine gun company (fig. 12), one rifle company (fig. 12), a headquarters company, a maintenance company, and an engineer platoon (fig. 42). T/O strength approximately 894.

(4) *Infantry companies*. Found in all types of infantry battalions and in the standard infantry regimental headquarters as the regimental sub-machine gun company. All infantry companies are either rifle, machine gun, or submachine gun in type, but all the rifle and machine gun companies contain both rifle and machine gun elements. There are seven different infantry company organizations.

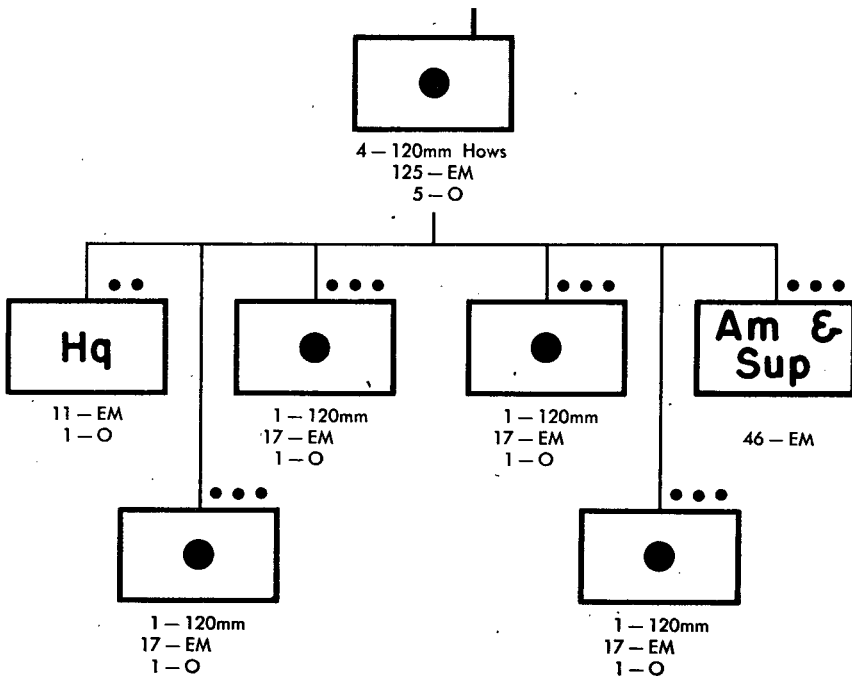

Figure 19. 120-mm. howitzer battery, artillery brigade.

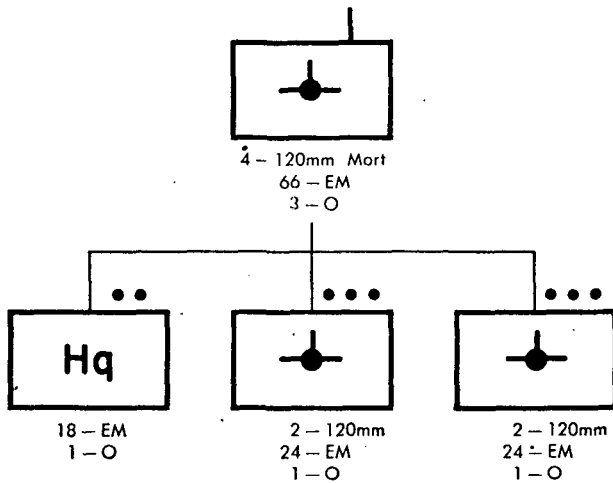

Figure 20. 120-mm. mortar battery, artillery brigade.

(a) *Rifle company, standard and armored infantry battalion* (fig. 12). Three in each standard infantry battalion, one in each armored infantry battalion (fig. 29). Consists of three rifle platoons and one mixed machine gun platoon (fig. 17). The machine gun platoon contains 4 heavy machine guns and 6 light machine guns, while each of the rifle platoons contains 4 light machine guns, one in each squad. T/O strength approximately 186-EM and 6-O.

(b) *Rifle company, light infantry battalion* (fig. 23). Five in each battalion. Consists of three rifle platoons, each platoon containing 3 light machine guns and one 50-mm mortar. T/O strength approximately 181-EM and 5-O.

(c) *Rifle company, parachute infantry battalion* (fig. 24). Four in each battalion. Consists of three rifle platoons and one light machine gun platoon. The machine gun platoon contains 9 light machine guns, while each rifle platoon carries a 50-mm mortar. T/O strength approximately 201-EM and 10-O.

(d) *Tank borne infantry company* (fig. 28). One in each armored infantry battalion (fig. 29). Consists of three rifle platoons and one machine gun platoon containing 8 light machine guns. T/O strength of approximately 164-EM and 6-O.

(e) *Machine gun company, light infantry battalion* (fig. 23). One in each battalion. Consists of four heavy machine gun platoons and an ammunition platoon. Each of the machine gun platoons contains two heavy machine guns. T/O strength approximately 144-EM, 6-O, and 1-WO (*Am Plat*).

(f) *Machine gun company, armored infantry battalion* (fig. 27). One in each battalion. Consists of three light platoons and one heavy platoon.

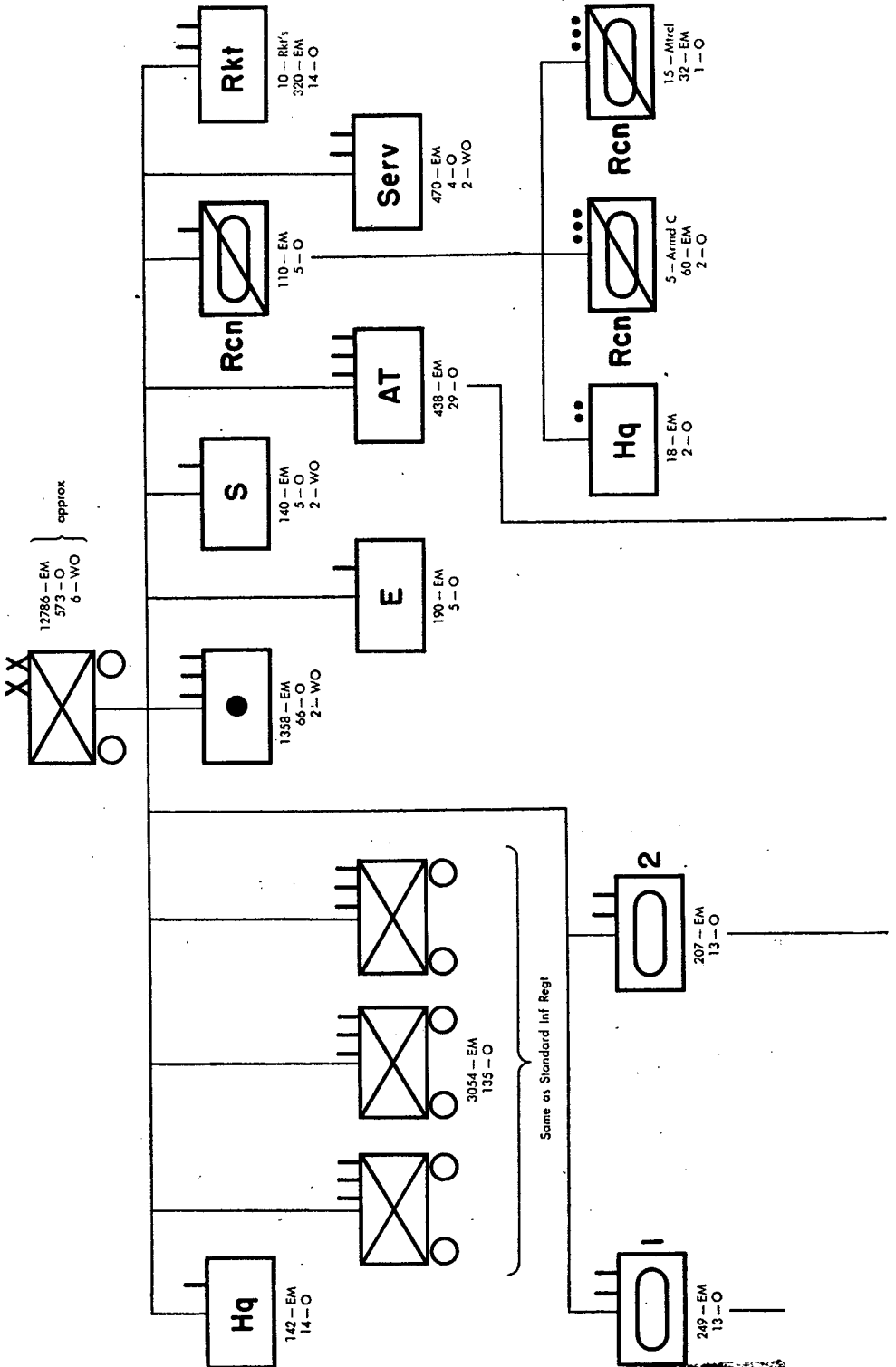

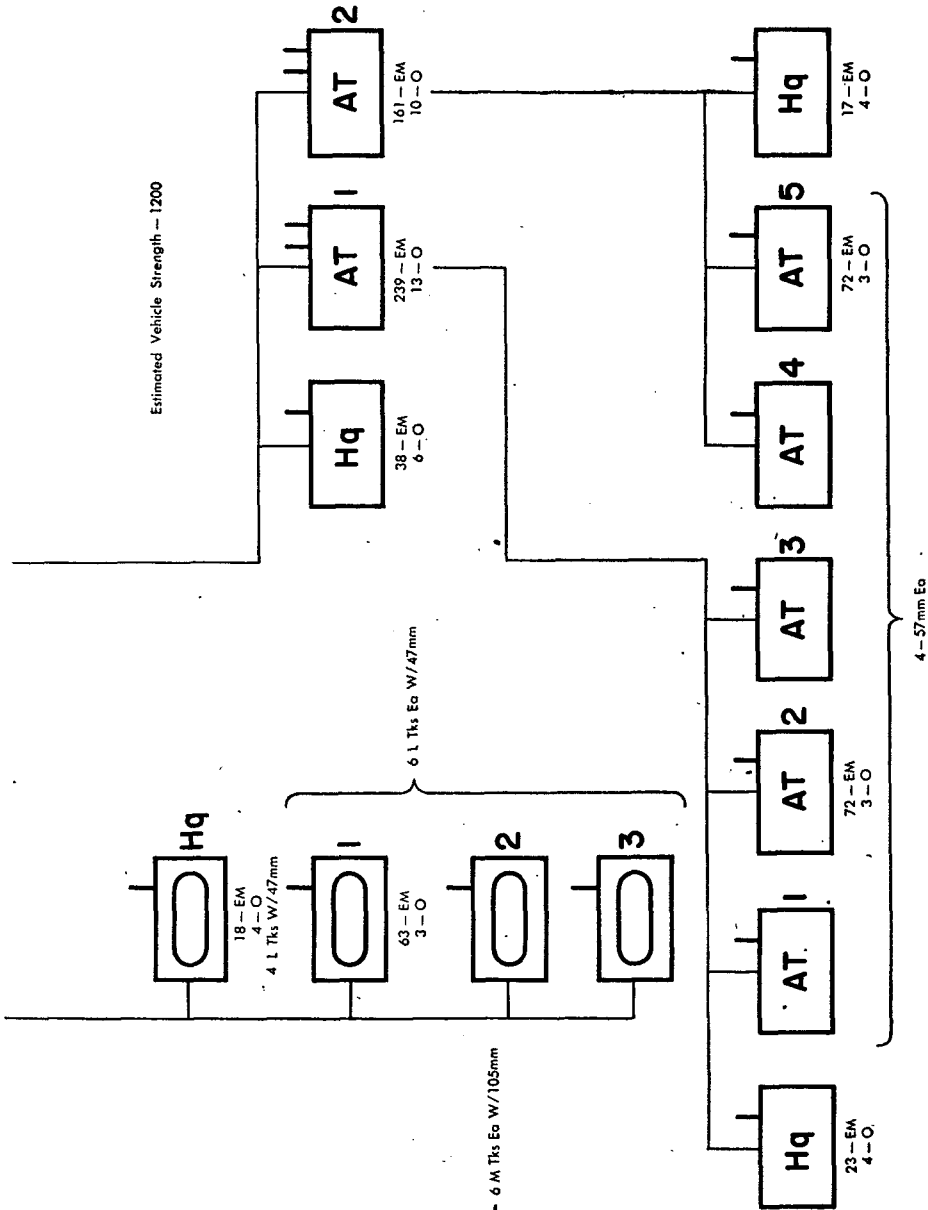
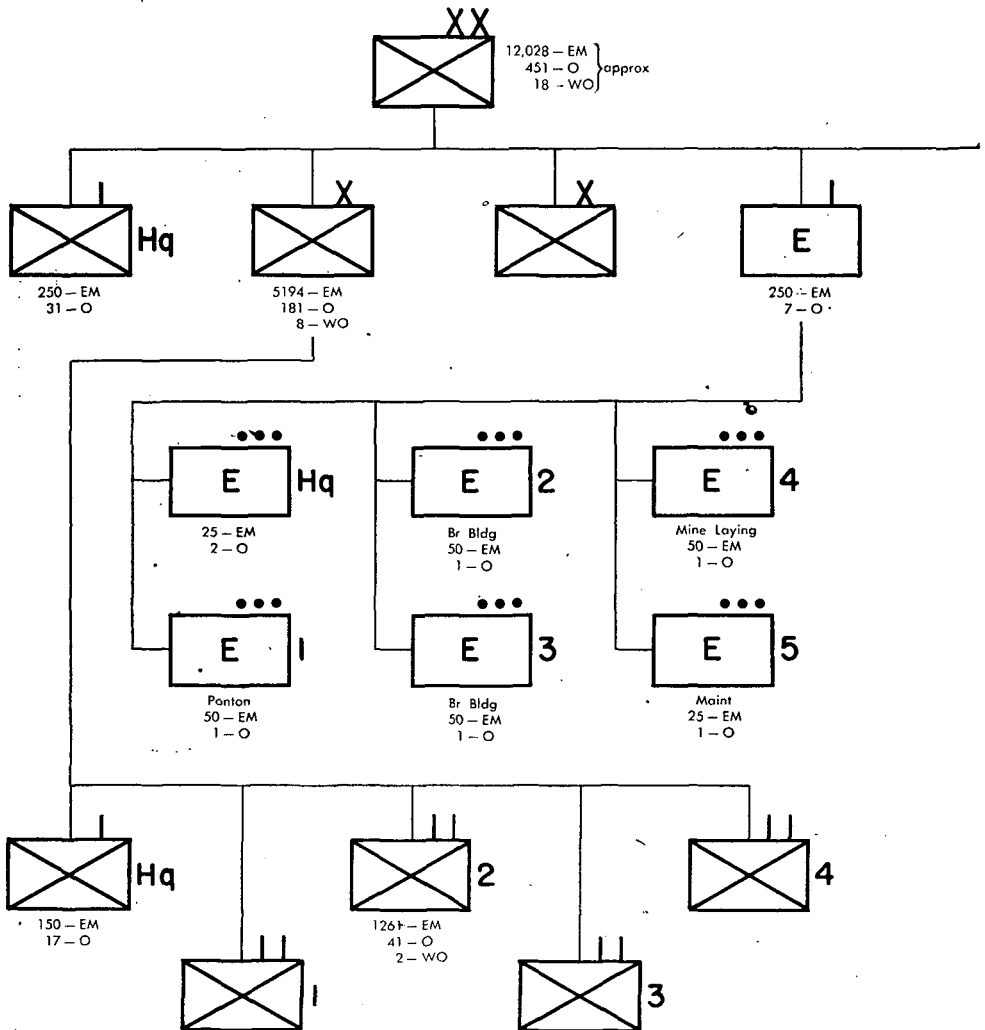

Figure 21. Motorized division.

Each of the light platoons contains 8 light machine guns, while the heavy platoon has 4 heavy machine guns. T/O strength approximately 164-EM and 6-O.

(g) *Submachine gun company* (fig. 12). One in each standard infantry regiment and armored infantry battalion (fig. 29). Consists of three platoons of three squads each. T/O strength approximately 107-EM and 5-O.

(5) *Reconnaissance company* (fig. 11). One in each infantry division,



Estimate Motor Vehicle Strength 300
Animals 200 (approx) in Trans Bn

motorized division (fig. 21), airborne brigade (fig. 24), and mechanized infantry regiment (fig. 26). Consists of an armored car platoon containing five armored cars and a motorcycle platoon containing fifteen motorcycles. T/O strength approximately 110-EM and 5-O.

b. Non-divisional infantry units. These include raiding battalions, machine gun battalions, ski battalions, and fortress battalions. Of all of these, however, detailed information is available for only the ski battalion and the machine gun battalion which is normally organic to a corps headquarters.

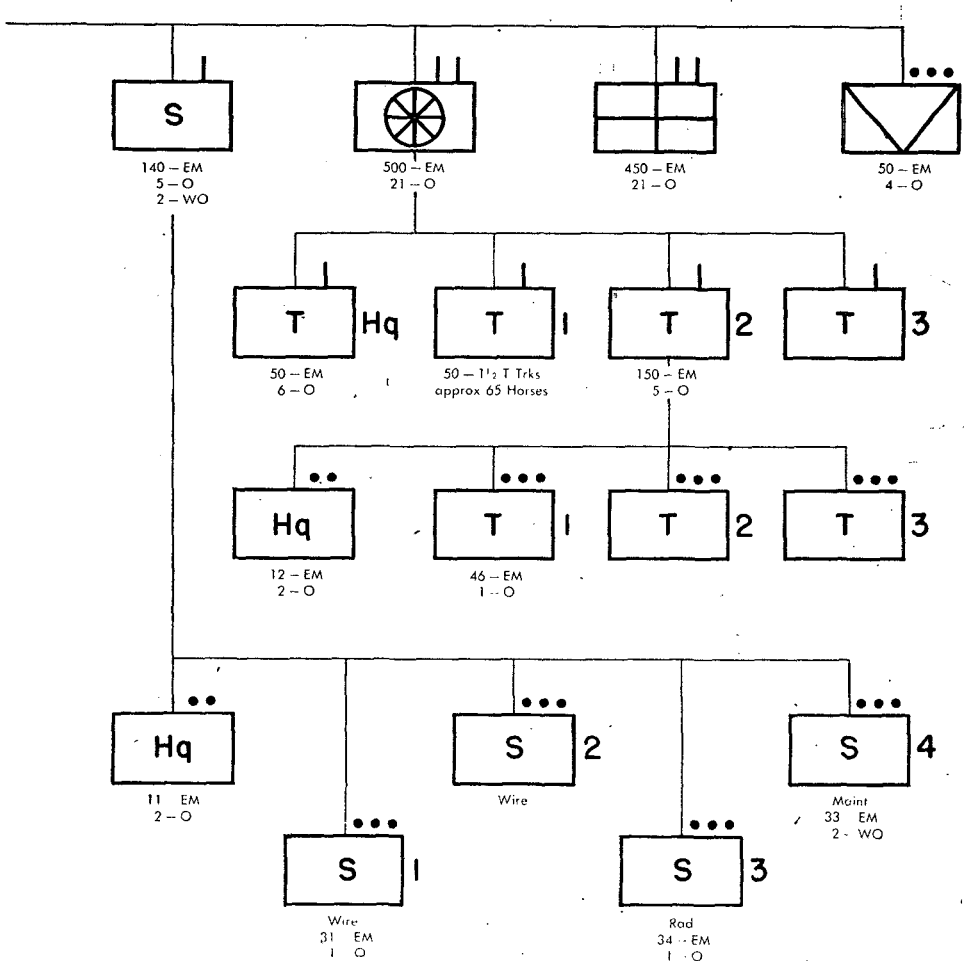
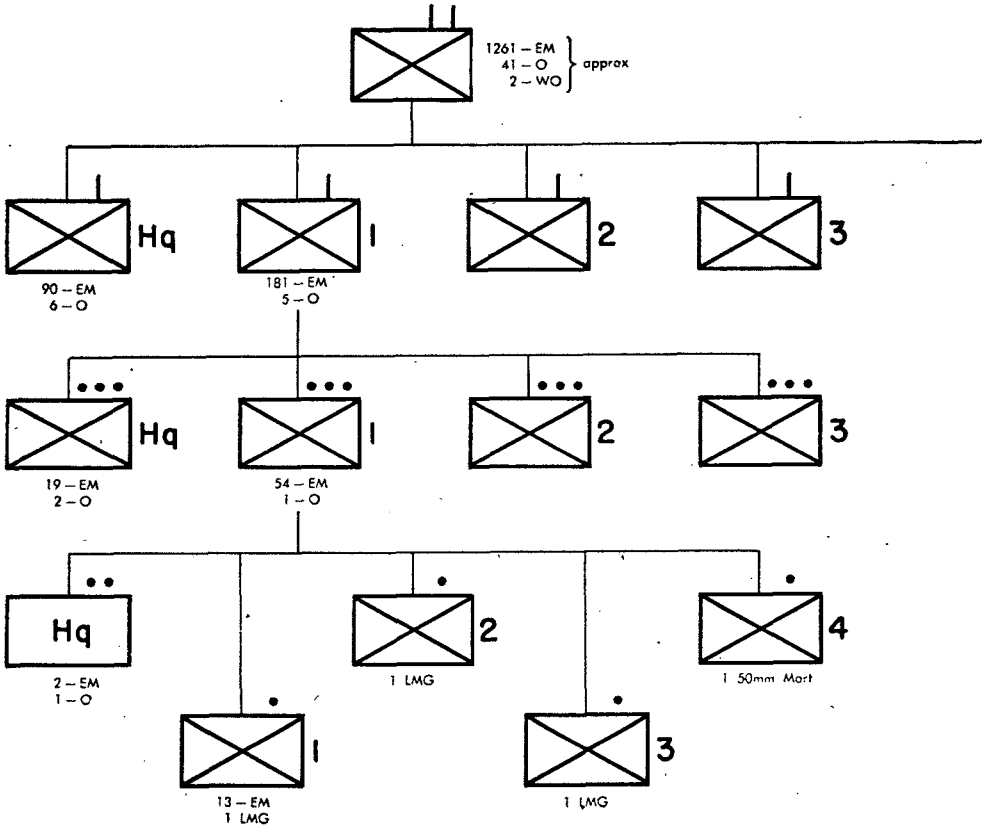
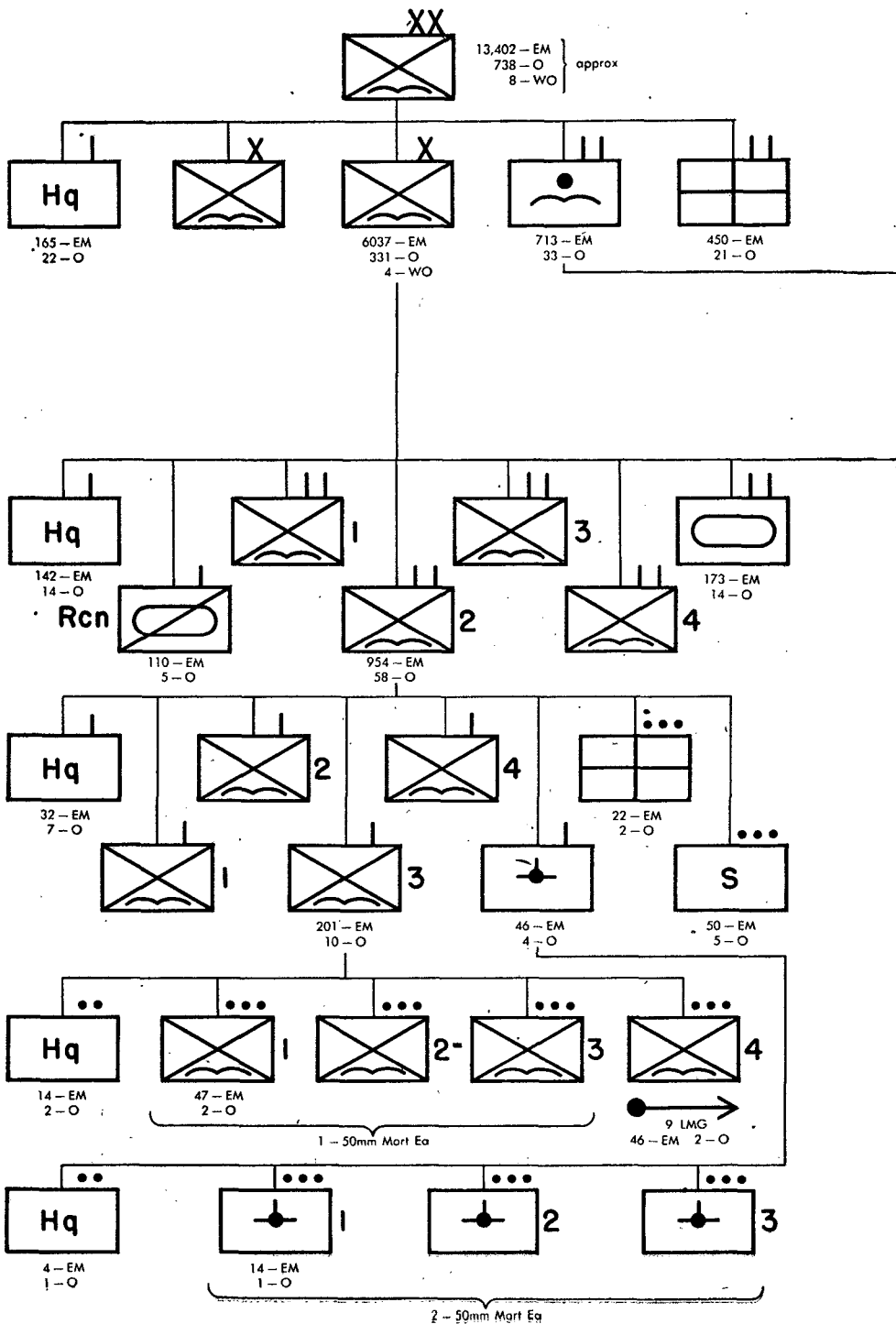

Figure 22. Light division.

(1) *Ski battalion* (fig. 36). Consists of three rifle companies, a weapons company, and a headquarters company. Its T/O strength is approximately 825 men and officers. Each of the rifle companies contains approximately 190-EM and 6-O and consists of three rifle platoons and an 81-mm mortar section. The mortar section contains two 81-mm mortars and each of the rifle platoons consists of three squads, each squad containing a machine gun and 8 submachine guns. The weapons company contains approximately 135-EM and 7-O and consists of a





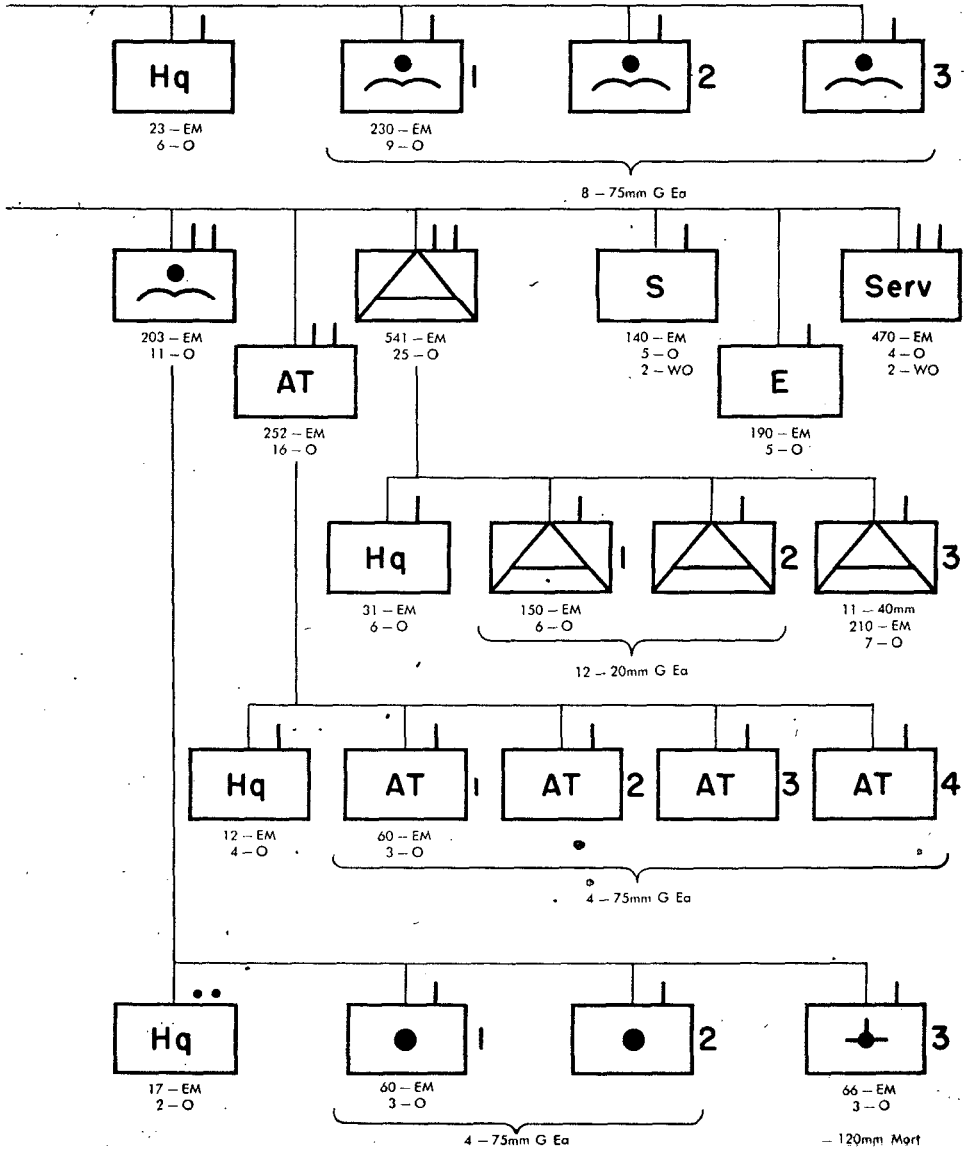

Figure 24. Airborne division.

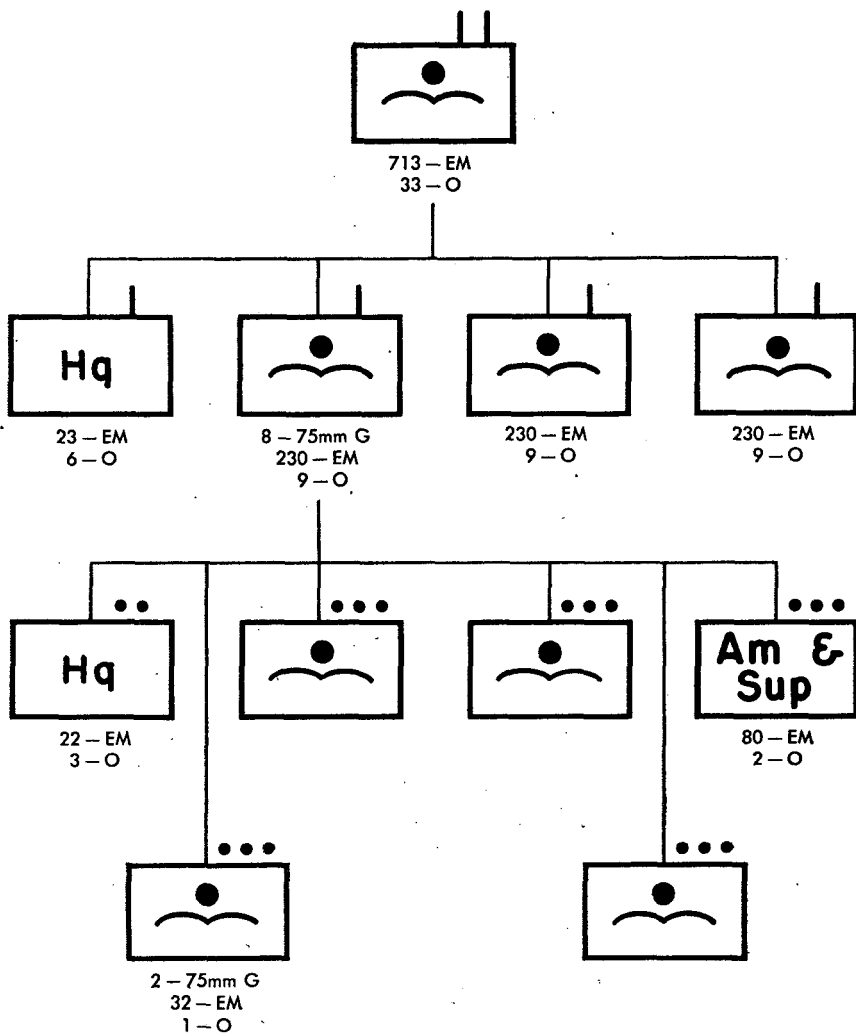

Figure 25. Artillery battalion, airborne division.

four heavy machine gun companies and a headquarters company. Each machine gun company has three platoons of four guns each. Strength is slightly over 700.

41. ARMORED TROOPS. This branch contains only the armored reconnaissance battalions and the tank units of the various divisions, in addition to the specialized GHQ armored troops.

a. Divisional armored units. (1) *Tank regiments.* Found in the armored, mechanized, and cavalry divisions. There are two types of

tank regiments: those in the armored and cavalry divisions, and those in the mechanized divisions; the former carry an armored infantry battalion and a signal company, the latter have only tank companies.

(a) *Tank regiment, armored and cavalry divisions* (fig. 29). Three in each armored division, one in each cavalry division (fig. 31). Consists of two tank battalions of two companies each, one armored infantry battalion, a signal company (fig. 22), and a headquarters company. Each tank battalion contains 26 medium tanks, while the headquarters company contains 6 medium tanks; total for the regiment 58. T/O strength approximately 1,462.

(b) *Tank regiment, mechanized division* (fig. 26). Two in each mechanized division. Consists of three tank battalions of three companies each and a headquarters company. Each battalion contains 37 medium tanks, while the headquarters company contains 6; total for the regiment 117. T/O strength approximately 848.

(2) *Tank battalions*. Found in the tank regiments of the armored, mechanized, and cavalry divisions, and as separate battalions in the motorized division, the airborne brigade of the airborne division, and in the mechanized infantry regiment. There are four types.

(a) *Tank battalion, tank regiment of the armored and cavalry divisions, the airborne brigade of the airborne division, and the mechanized infantry regiment* (fig. 29). Two in each tank regiment of the armored and cavalry divisions, one in each airborne brigade (fig. 24), and one in each mechanized infantry regiment. Consists of two tank companies and a headquarters company. Each tank company contains 11 medium tanks, while the headquarters company contains 4 medium tanks; total for the battalion 26. T/O strength approximately 173-EM and 14-O.

(b) *Tank battalion, tank regiment of the mechanized division* (fig. 26). Three in each regiment. Consists of three tank companies and a headquarters company. Each tank company contains 11 medium tanks, while the headquarters company contains 4 tanks; total for the battalion 37. T/O strength approximately 267.

(c) *Medium tank battalion, motorized division* (fig. 21). One of the two tank battalions in the motorized division. Consists of three tank companies and a headquarters company. Each tank company contains 6 medium tanks equipped with 105-mm howitzers, while the headquarters company contains 4; total for the battalion 22. T/O strength approximately 249-EM and 13-O.

(d) *Light tank battalion, motorized division* (fig. 21). The second of the two tank battalions of the motorized division. Consists of three tank companies and a headquarters company. Each tank company contains 6 light tanks equipped with 47-mm guns, while the headquarters company contains 4; total for the battalion 22. T/O strength approximately 207-EM and 13-O.

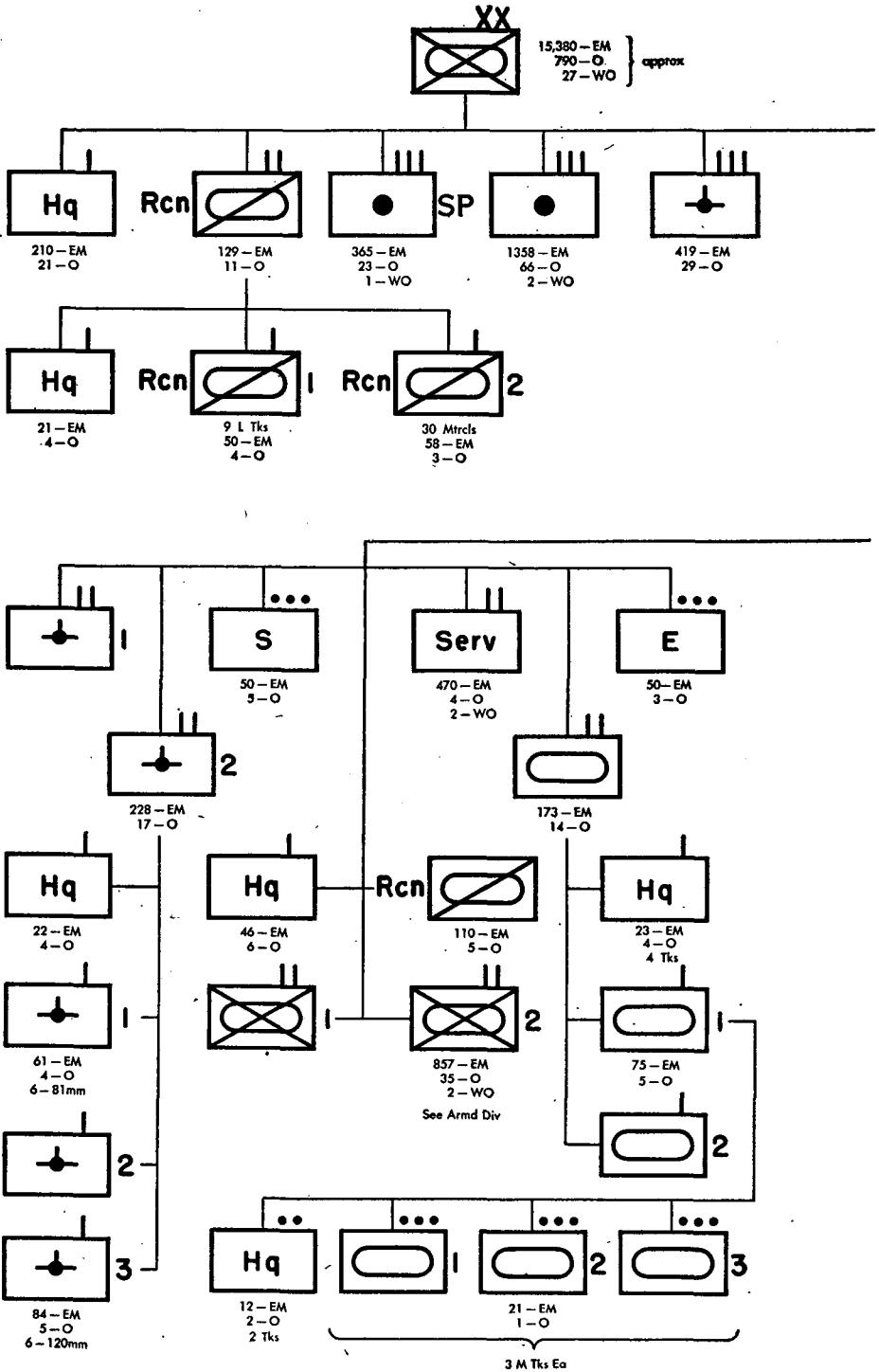

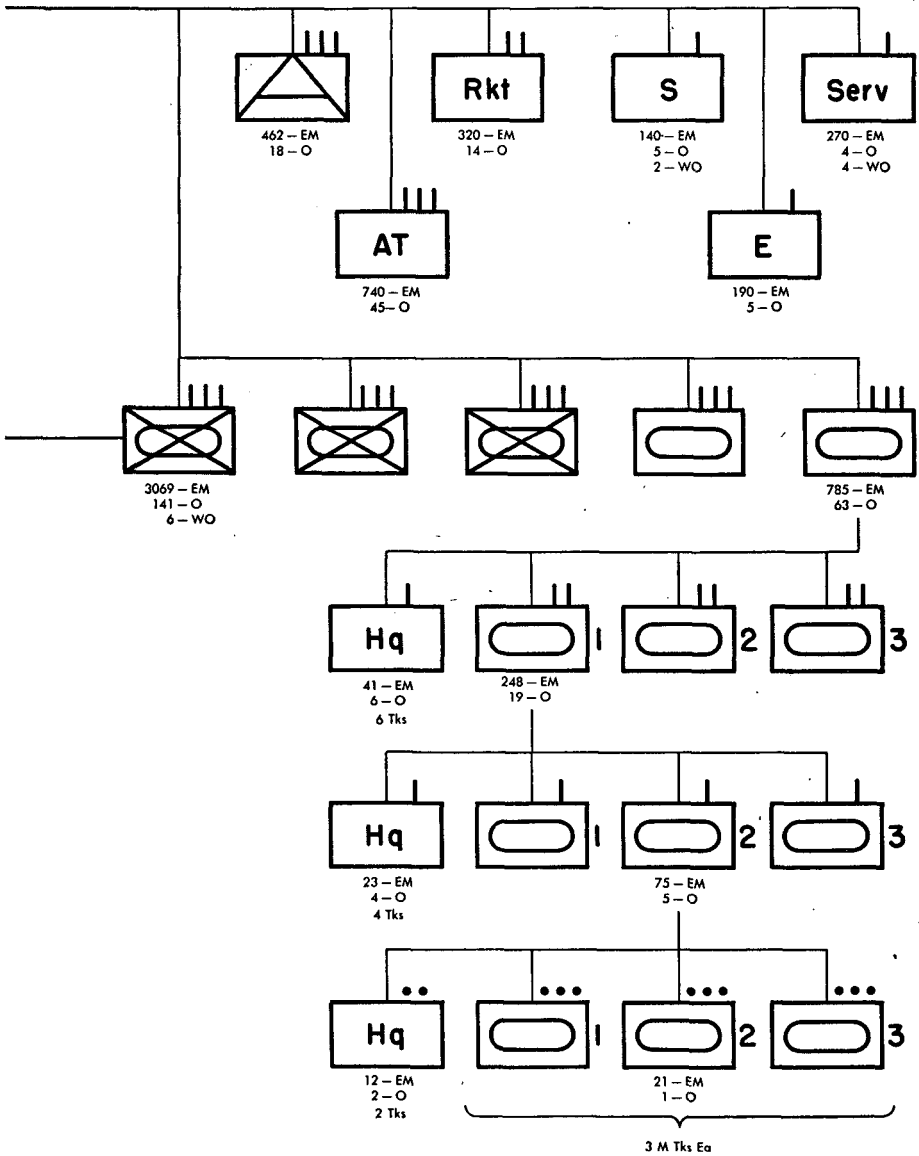

Figure 26. Mechanized division.



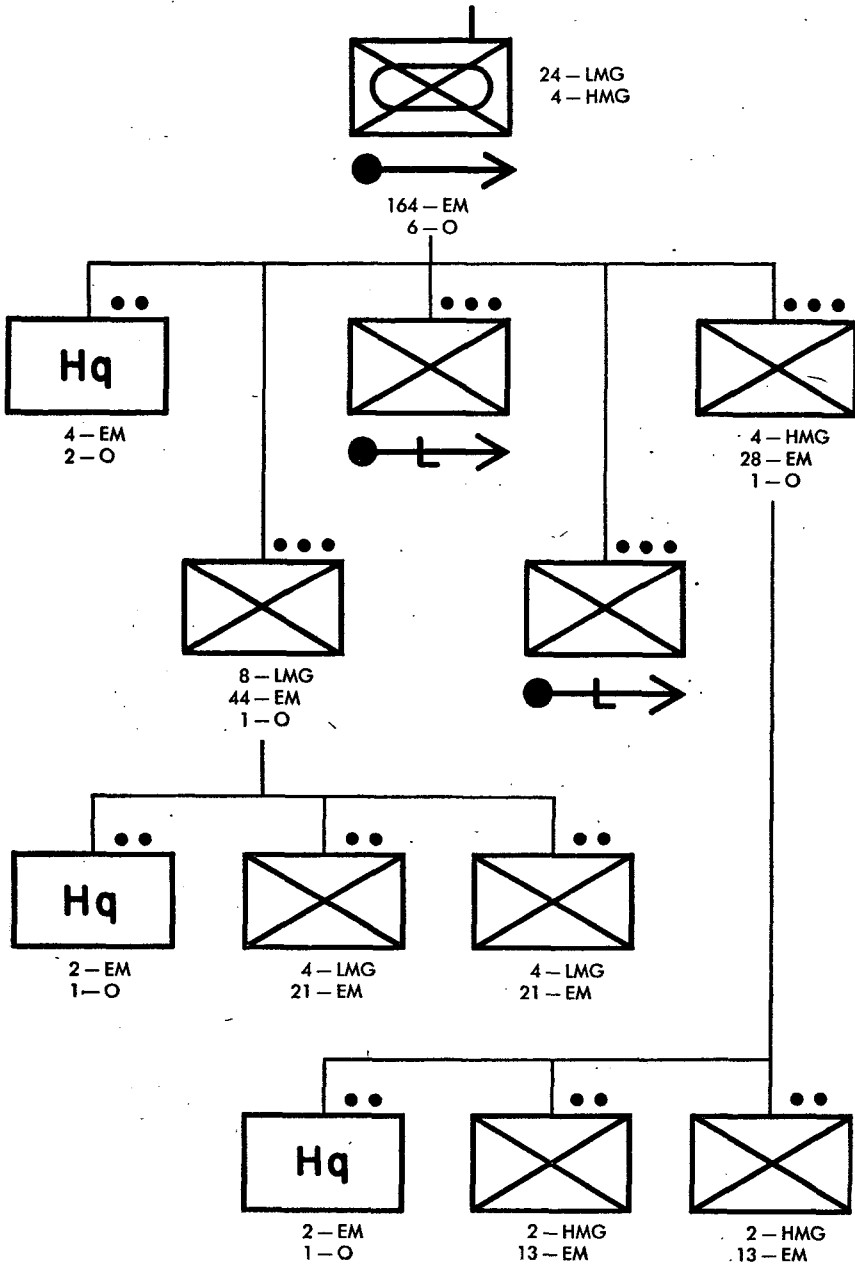

Figure 27. Machine gun company, armored and mechanized infantry battalions.

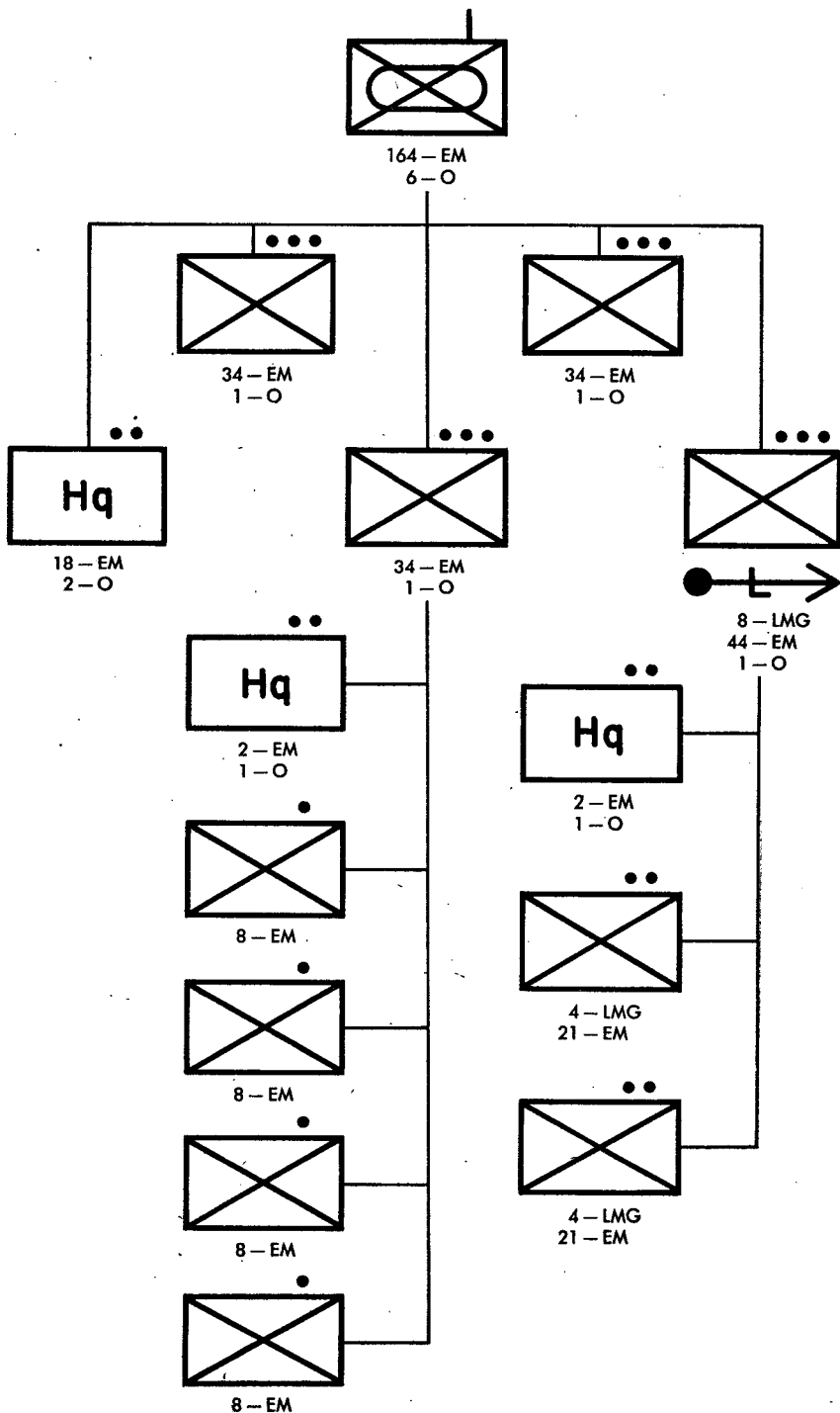
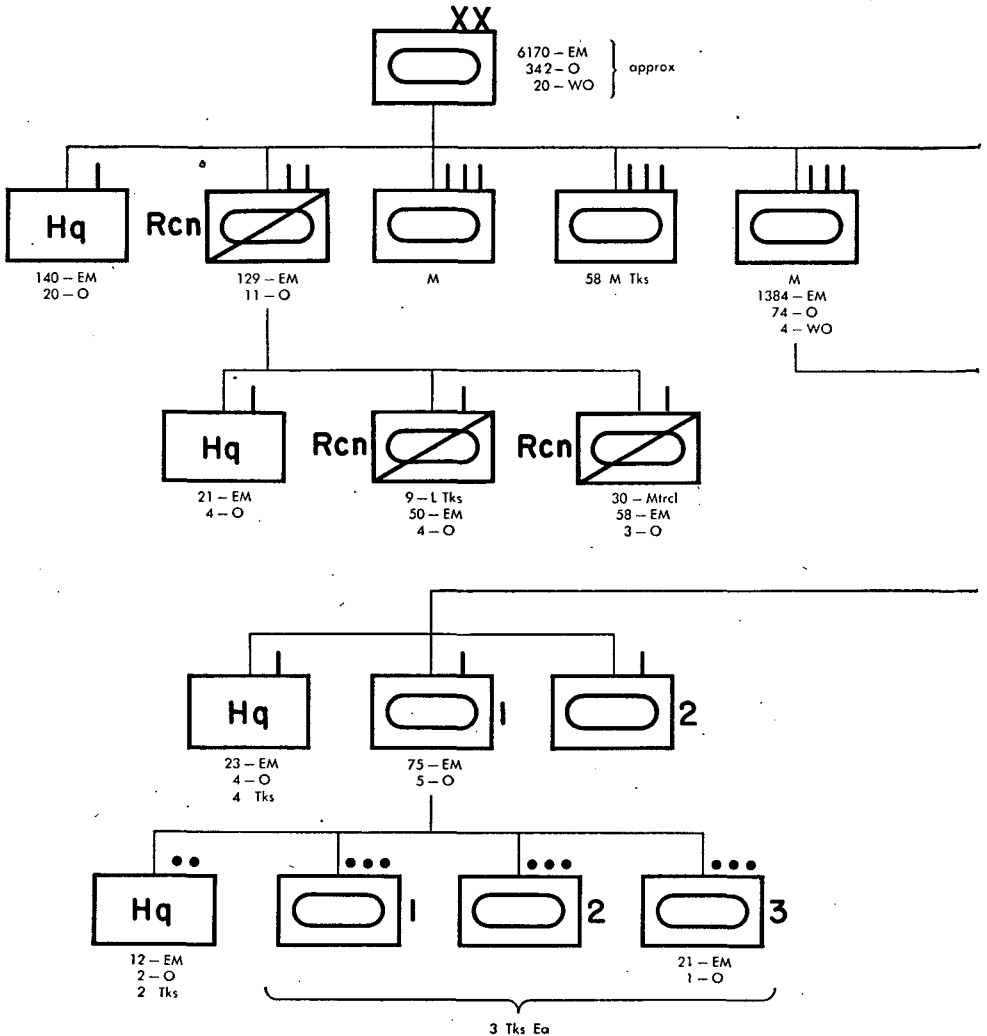

Figure 28. Tank borne infantry, armored infantry battalion.

(3) *Tank companies.* Found only as subordinate units of tank battalions. There are three types: medium, medium with 105-mm howitzers, and light with 47-mm guns.

(a) *Medium tank company* (figs. 26 and 29). Two in the tank battalion of the airborne brigade (fig. 24), the tank battalion of the mechanized infantry regiment, and the tank battalion of the tank regiments in the armored and cavalry divisions (fig. 31); three in the tank battalion of the tank regiment in the mechanized division. Consists of



three platoons and a headquarters section. Each tank platoon contains 3 medium tanks, and the headquarters section contains 2; total for the company, 11. T/O strength approximately 75-EM and 5-O.

(b) *Medium tank company with 105-mm howitzers* (fig. 21). Three in the medium tank battalion of the motorized division. Each company contains 6 medium tanks equipped with 105-mm howitzers and has a T/O strength of approximately 77-EM and 3-O.

(c) *Light tank company with 47-mm guns* (fig. 21). Three in the

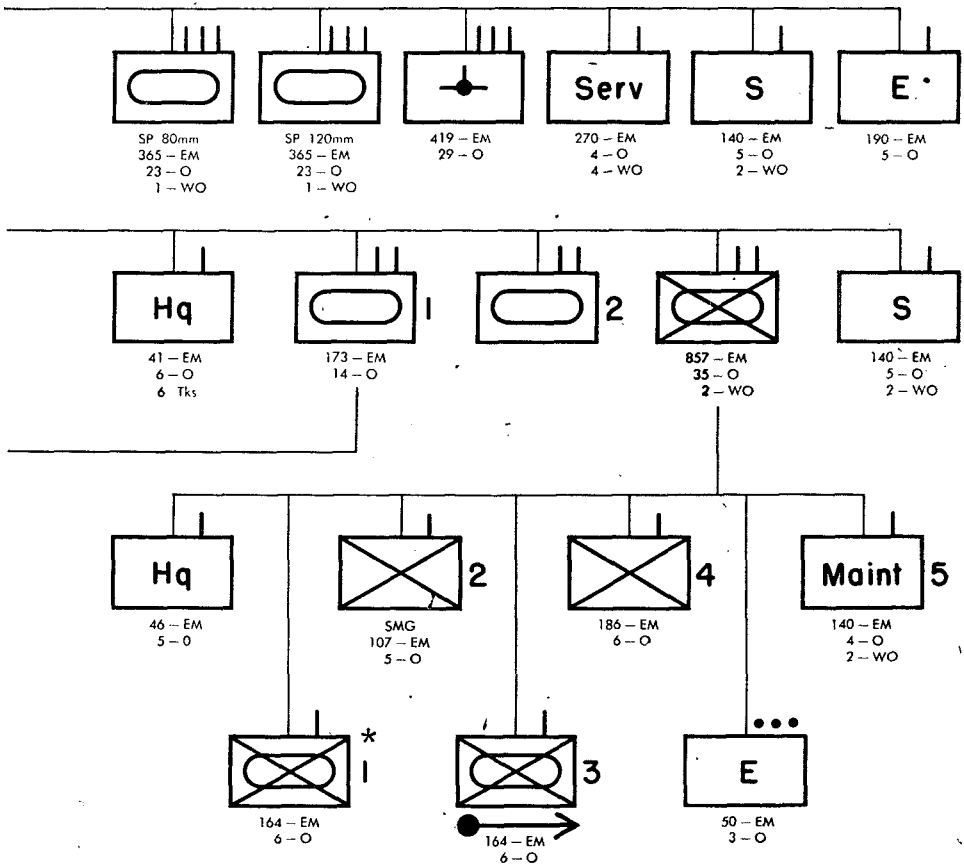

Estimated Tank Strength 200

* Tk Borne Inf Co

Figure 29. Armored division.

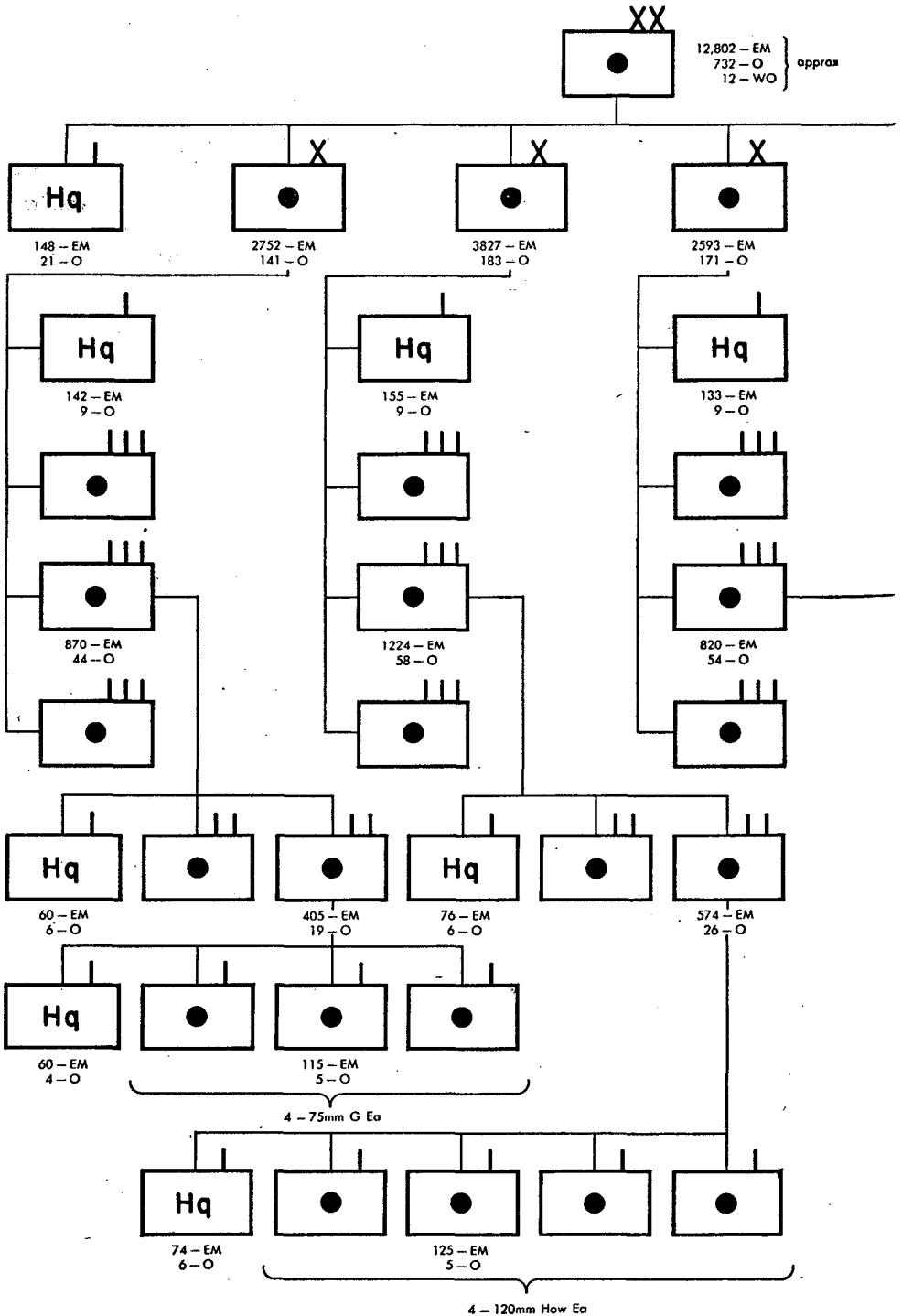

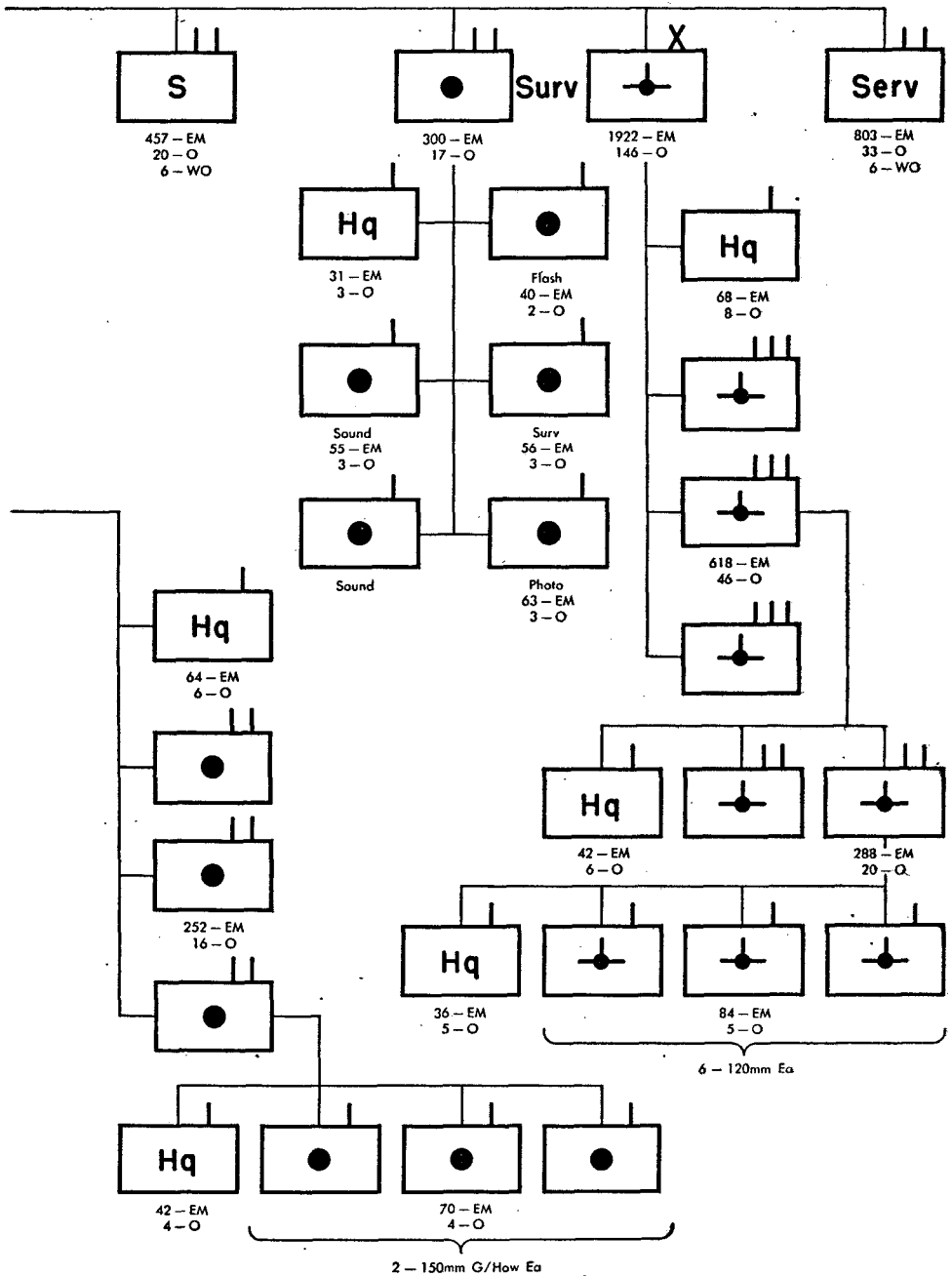
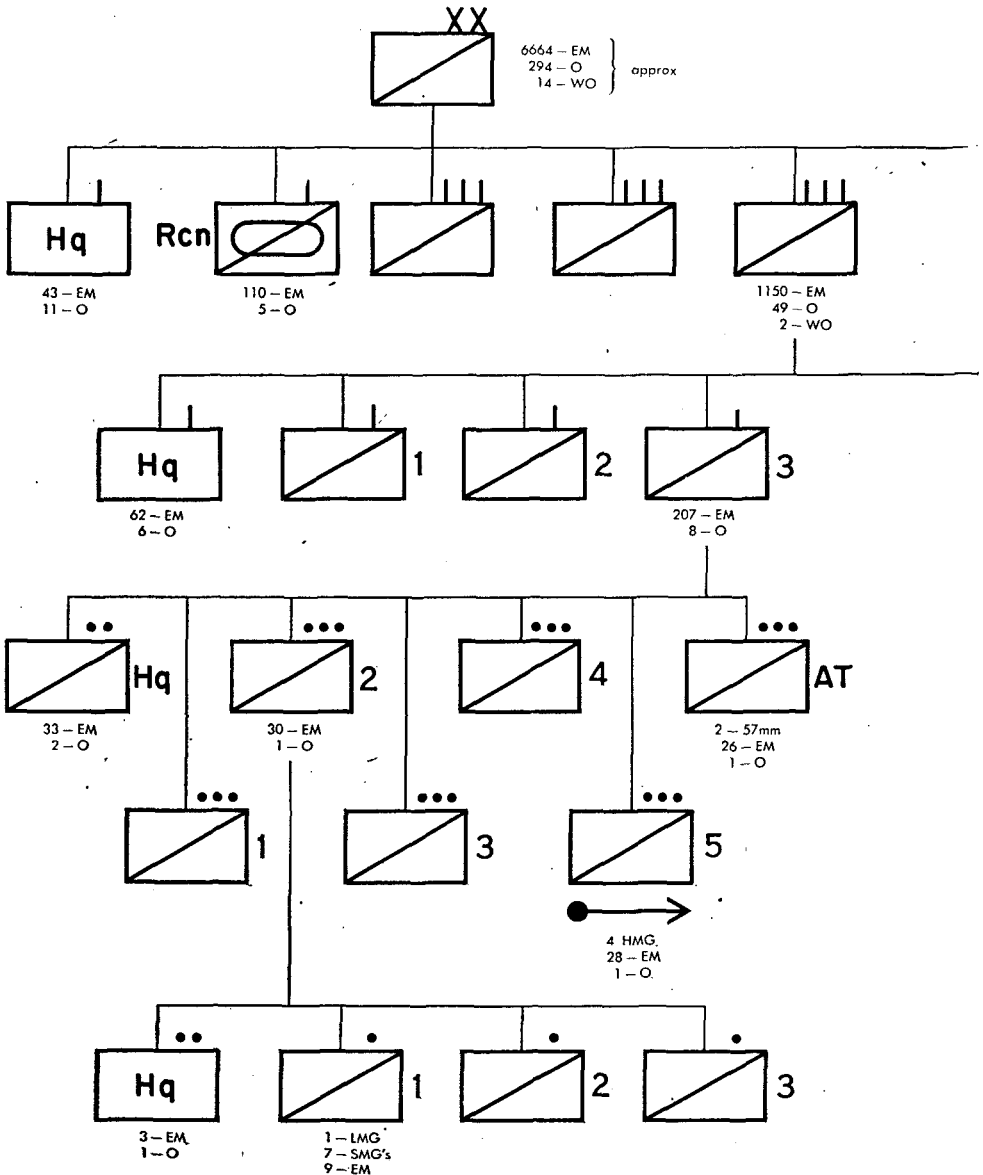

Figure 30. Artillery division.

light tank battalion of the motorized division. Each company contains 6 light tanks equipped with 47-mm guns and has a T/O strength of approximately 63-EM and 3-O.

(4) *Armored reconnaissance battalion.* One in each armored division (fig. 29) and each mechanized division (fig. 26). Consists of a tank reconnaissance company, a motorcycle reconnaissance company, and a headquarters company. T/O strength approximately 129-EM and 11-O.



(5) *Armored reconnaissance companies.* Found in the armored reconnaissance battalion of the armored division (fig. 29) and the mechanized division (fig. 26). There are two types: tank reconnaissance company and motorcycle reconnaissance company.

(a) *Tank reconnaissance company.* One in each armored reconnaissance battalion (figs. 26 and 29). Contains 9 light tanks and has a T/O strength of approximately 50-EM and 4-O.

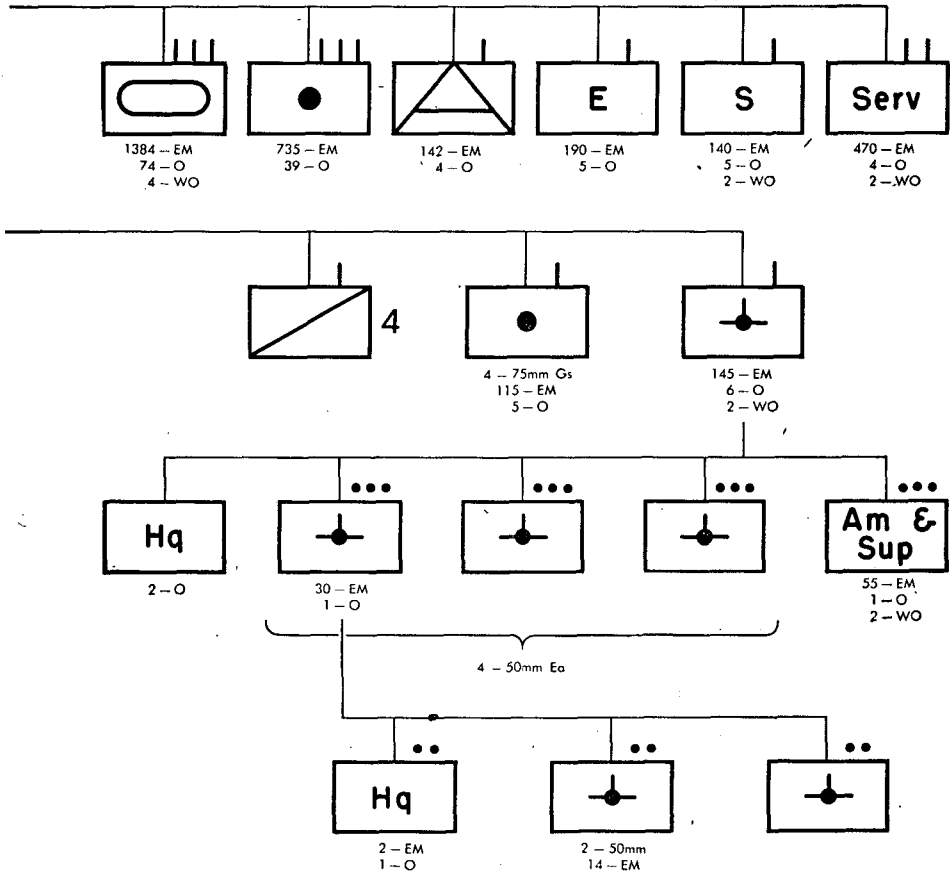

Figure 31. Cavalry division.

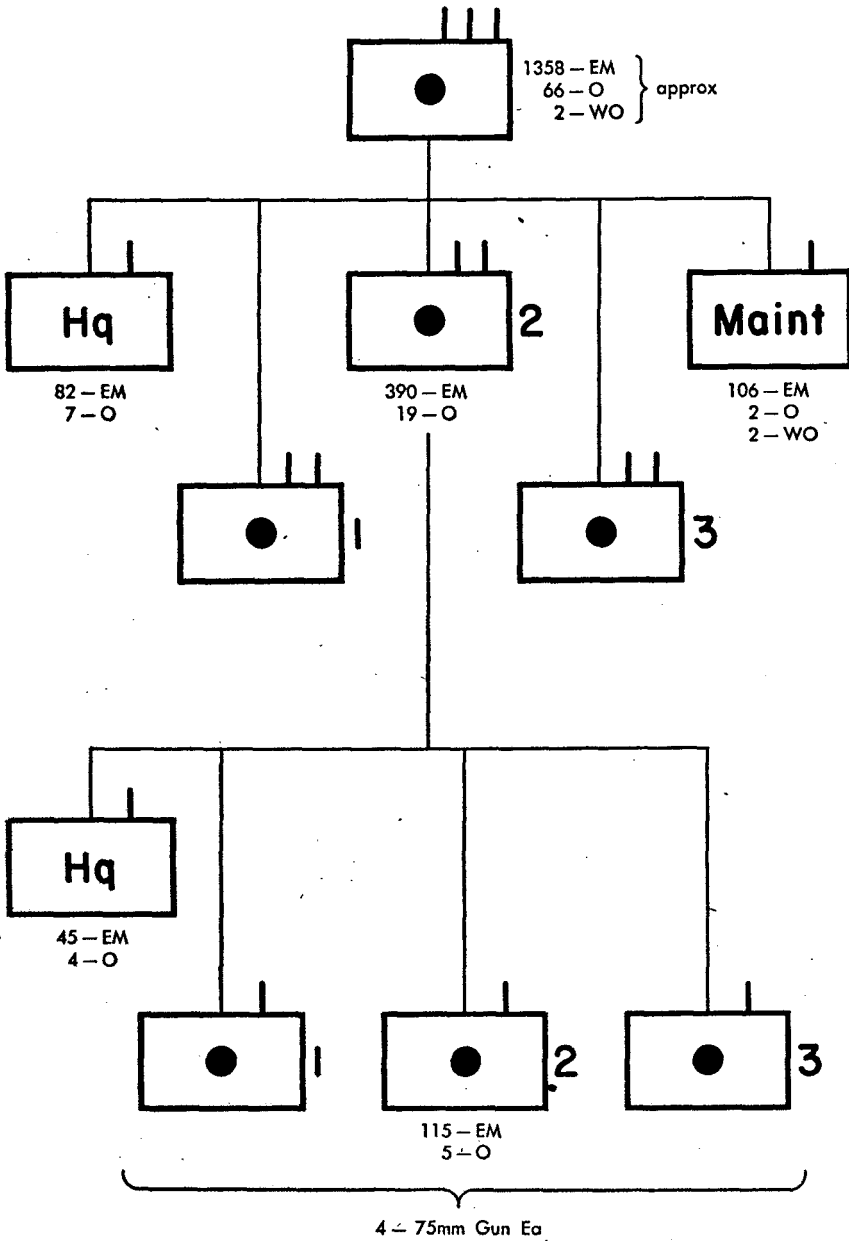

Figure 32. Artillery regiment (truck drawn), motorized and mechanized divisions.

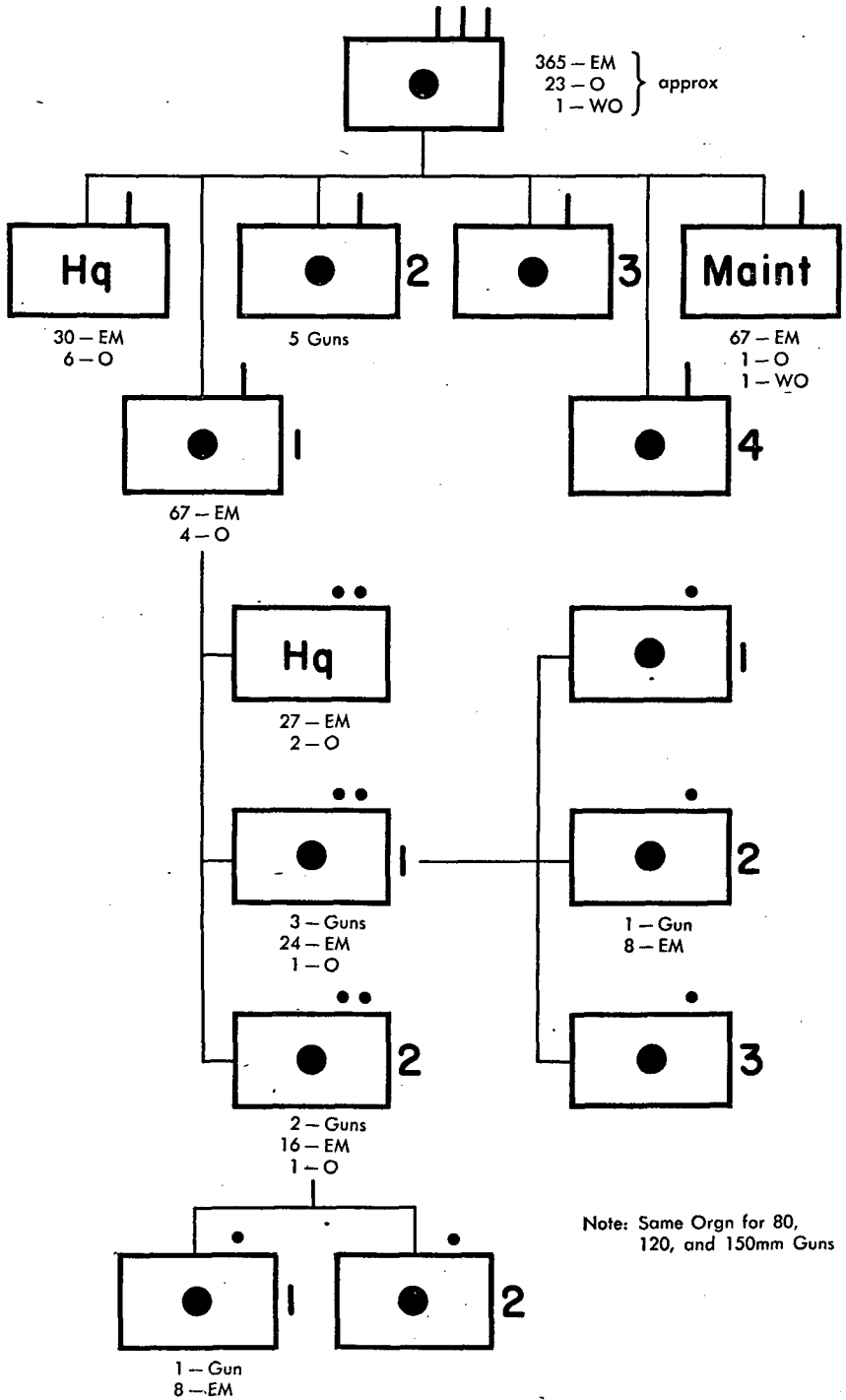

Figure 33. Artillery regiment (SP).

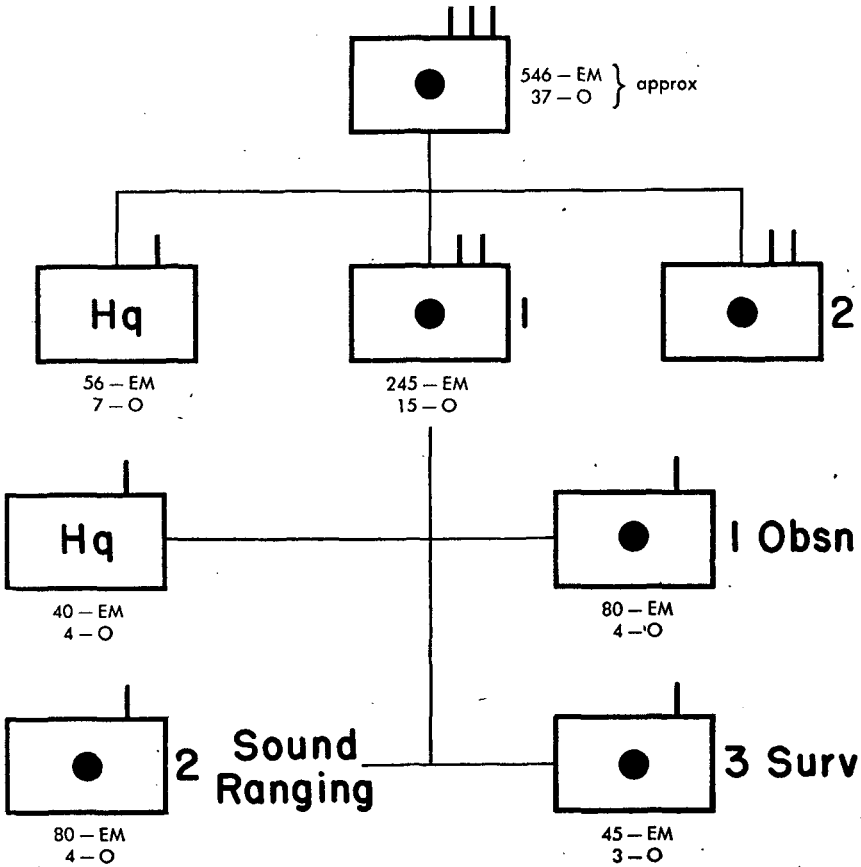

Figure 34. Survey regiment (corps troops).

(b) *Motorcycle reconnaissance company.* One in each armored reconnaissance battalion (figs. 26 and 29). Contains 30 armored motorcycles and has a T/O strength of approximately 58-EM and 3-O.

b. Non-divisional armored units. (1) GHQ armored troops include heavy tank battalions, flame thrower battalions, heavy antitank battalions, heavy assault gun battalions, armored reconnaissance battalions, armored trains, and tank repair battalions. Organizational charts are not available for any of these, except the flame thrower battalion.

(2) *Flame thrower battalion* (fig. 37). Consists of three flame thrower companies, a headquarters company, and a maintenance company. Each flame thrower company consists of three platoons, each containing 4 flame thrower tanks, and a tank platoon containing 4 medium tanks. T/O strength approximately 478.

42. CAVALRY. This branch covers only the cavalry and reconnaissance troops of the cavalry division.

a. Divisional cavalry units. (1) *Cavalry regiment* (fig. 31). Three in each cavalry division. Consists of four cavalry troops, a 75-mm gun battery (fig. 18), a 50-mm mortar battery, and a headquarters troop. T/O strength approximately 1,201.

(2) *Cavalry troop* (fig. 31). Four in each cavalry regiment. Consists of four mounted rifle platoons, one mounted heavy machine gun platoon, and a 57-mm antitank platoon. The machine gun platoon contains four heavy machine guns, while each rifle platoon contains one light machine gun and seven submachine guns; the antitank platoon contains two 57-mm antitank guns.

(3) *Reconnaissance Company* (fig. 11). One to each cavalry division (fig. 31). Identical to that of the infantry division. Consists of an armored car platoon containing 5 armored cars and an armored motorcycle platoon containing 15 armored motorcycles. T/O strength approximately 110-EM and 5-O.

b. Non-divisional cavalry units. None.

43. ARTILLERY. This branch contains all the artillery, mortar, antitank, and antiaircraft units of battery or company size and higher and the rocket and survey battalions; it does not include the personnel of the separate heavy weapons platoons or sections of the infantry-type companies or the cavalry troop. There are also many special GHQ and Corps troops units including such specialized units as survey regiments and air observation post squadrons; a complete list is given below under non-divisional artillery units.

a. Divisional artillery units. (1) *Artillery brigades.* Found only in the artillery division (fig. 30) and the infantry division (fig. 11). There are four types, classified according to weapon and caliber: the 75-mm gun, 120-mm howitzer, and 150-mm gun/howitzer brigades in the artillery division, and the mixed artillery brigade of the infantry division. In both the infantry and the artillery divisions, the battery organization for any one type of weapon is identical; it is only the groupings of the batteries and battalions that are different. All the artillery brigades have three regiments each.

(a) *75-mm gun brigade, artillery division* (fig. 30). One in each artillery division. Consists of three regiments of two battalions each; there are three 75-mm gun batteries in each battalion, 4 guns to each battery. The brigade has a total of 72 75-mm guns and a T/O strength of approximately 2,893.

(b) *120-mm howitzer brigade, artillery division* (fig. 30). One in each artillery division. Consists of three regiments of two battalions

each; there are four 120-mm howitzer batteries in each battalion, 4 howitzers to each battery. The brigade has a total of 96 *120-mm howitzers* and a T/O strength of approximately 4,010.

(c) *150-mm gun/howitzer brigade, artillery division* (fig. 30). One in each artillery division. Consists of three regiments of three battalions each; there are three 150-mm gun/howitzer batteries in each battalion, 2 gun/howitzers to each battery. The brigade has a total of 54 *150 gun/howitzers* and a T/O strength of approximately 2,764.

(d) *Artillery brigade, infantry division* (fig. 18). One in each infantry division. Consists of one regiment of 75-mm guns, one regiment of 120-mm howitzers, one regiment of 120-mm mortars, a service battery, and a headquarters company. In each case there are two battalions to the regiment; one of the battalions has three batteries and the other battalion two batteries. There are 4 weapons in each battery, making a total of 20 of each type in the entire brigade. T/O strength of approximately 2,377.

(2) *Artillery regiments*. Found in all types of divisions, except light and airborne. There are seven different types of regiments, the distinction usually being in organizational structure only. All the batteries of a given caliber have identical organization, but the battalion groupings vary.

(a) *75-mm gun regiment, artillery division* (fig. 30). Three in the 75-mm gun brigade of the artillery division. Consists of two battalions of three batteries each, 4 guns to each battery. Contains a total of 24 *75-mm guns* and has a T/O strength of approximately 914.

(b) *75-mm gun regiment, infantry and cavalry divisions* (fig. 18). One in the artillery brigade of the infantry division and in each cavalry division. Consists of two battalions, one battalion having three batteries and the other having two batteries; each battery has 4 guns. Contains a total of 20 *75-mm guns* and has a T/O strength of approximately 774.

(c) *75-mm gun regiment, truck-drawn* (fig. 32). One in each motorized and mechanized division. Consists of three battalions of three batteries each, 4 guns to each battery. Contains a total of 36 *75-mm truck-drawn guns* and has a T/O strength of approximately 1,426.

(d) *120-mm howitzer regiment, artillery division* (fig. 30). Three in the 120-mm howitzer brigade of the artillery division. Consists of two battalions of four batteries each, 4 howitzers to each battery. Contains a total of 32 *120-mm howitzers* and has a T/O strength of approximately 1,282.

(e) *120-mm howitzer regiment, infantry division* (fig. 18). One in the artillery brigade of the infantry division. Consists of two battalions, one battalion having three batteries and the other having two batteries. Contains 20 *120-mm howitzers* and has a T/O strength of approximately 840.

(f) *Self-propelled artillery regiments* (fig. 33). Same organization for 80-mm, 120-mm, or 150-mm guns. One 80-mm artillery regiment

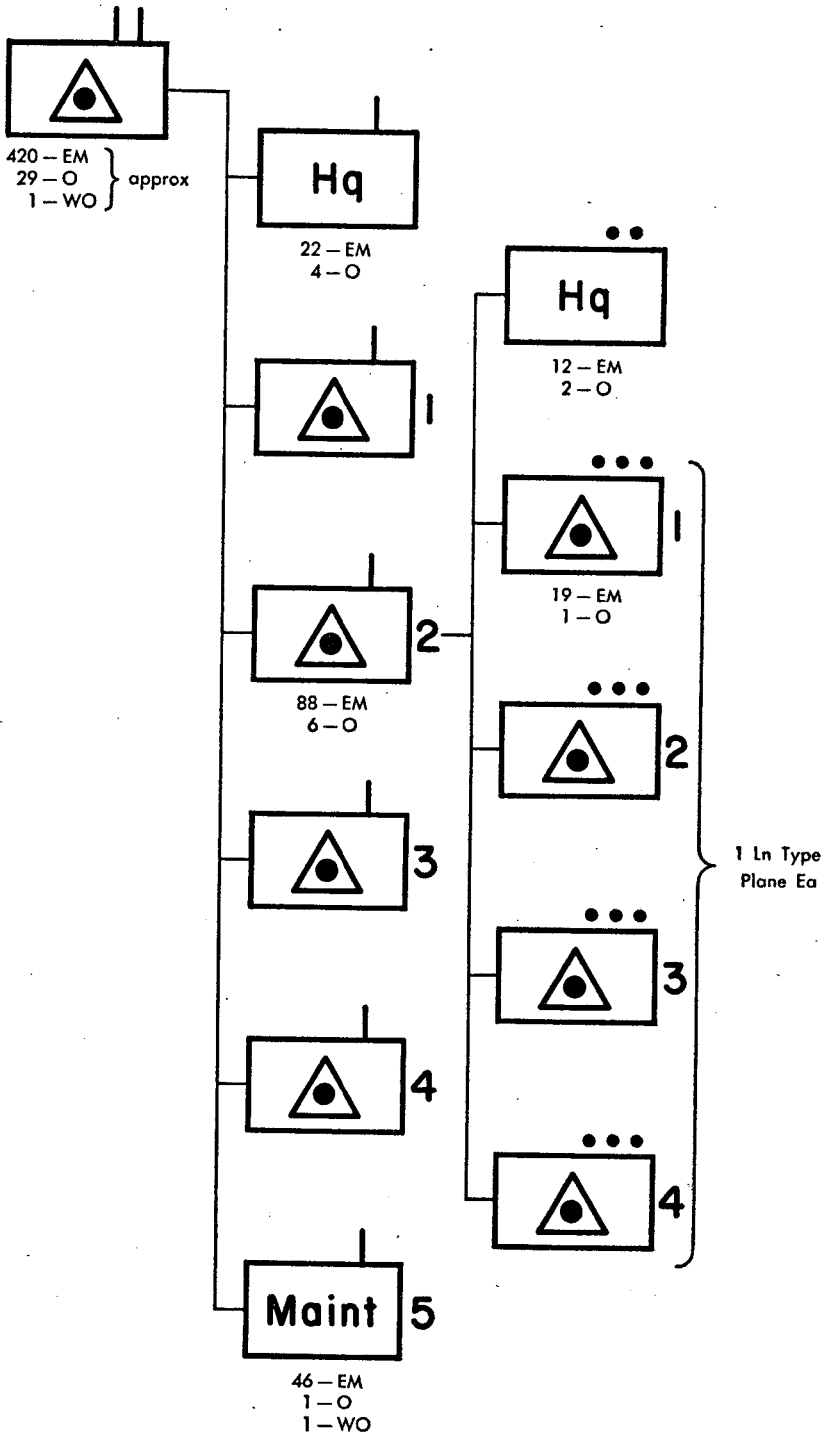
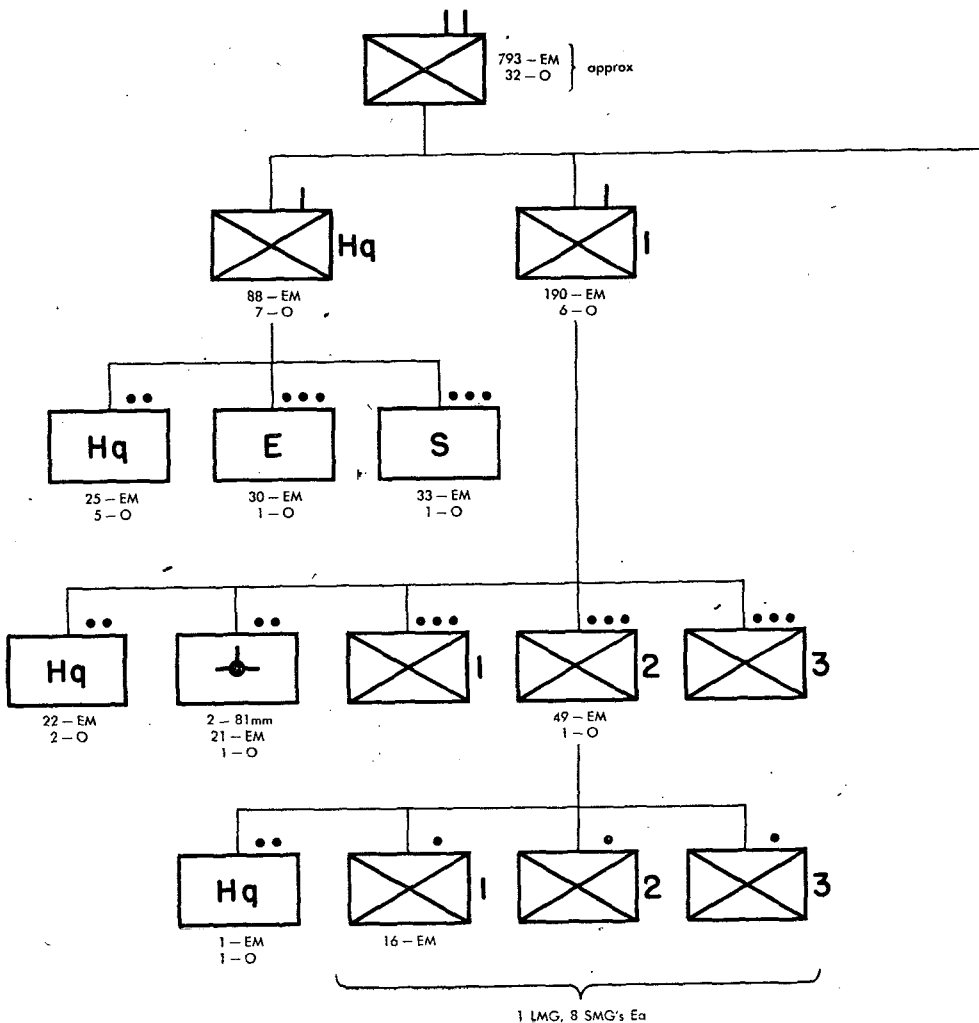

Figure 35. Air observation post squadron.

(SP) and one 120-mm artillery regiment (SP) are found in the armored division, and one of 150-mm guns is found in the mechanized division. Consists of four batteries of 5 guns each, one section having 3 guns and the second section having 2 guns. Contains a total of 20 self-propelled guns and has a T/O strength of approximately 389.

(g) 150-mm gun/howitzer regiment (fig. 30). Three in the 150-mm gun/howitzer brigade of the artillery division. Consists of three battalions of three batteries each, 2 gun/howitzers to each battery. Contains a total of 18 150-mm gun/howitzers and has a T/O strength of approximately 874.



(3) *Artillery battalions.* Found in all types of artillery regiments, except self-propelled; separate battalions are also found in the airborne division (fig. 24), a 75-mm gun battalion being in the airborne division headquarters (fig. 25) while each of the airborne brigades has a mixed artillery battalion. There are nine different battalion organizations, the usual distinction being one of battery groupings; in the case of the airborne artillery battalions, however, the batteries have a different organization.

(a) *75-mm gun battalion, 3-battery type* (figs. 18 and 30). Two in each 75-mm gun regiment of the artillery division, and one in the 75-mm

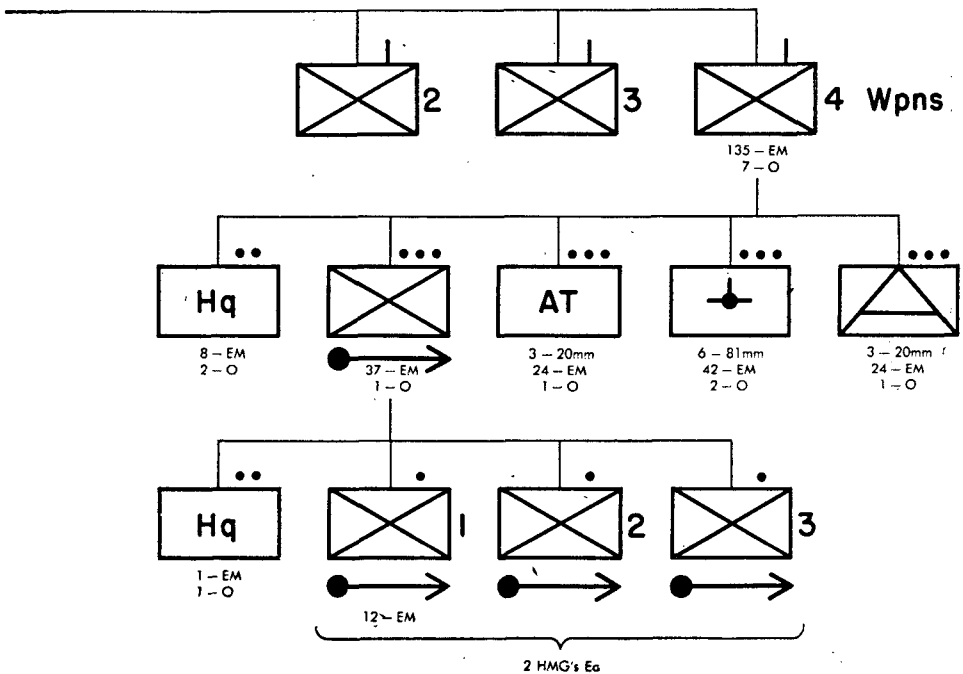

Figure 36., Ski battalion.

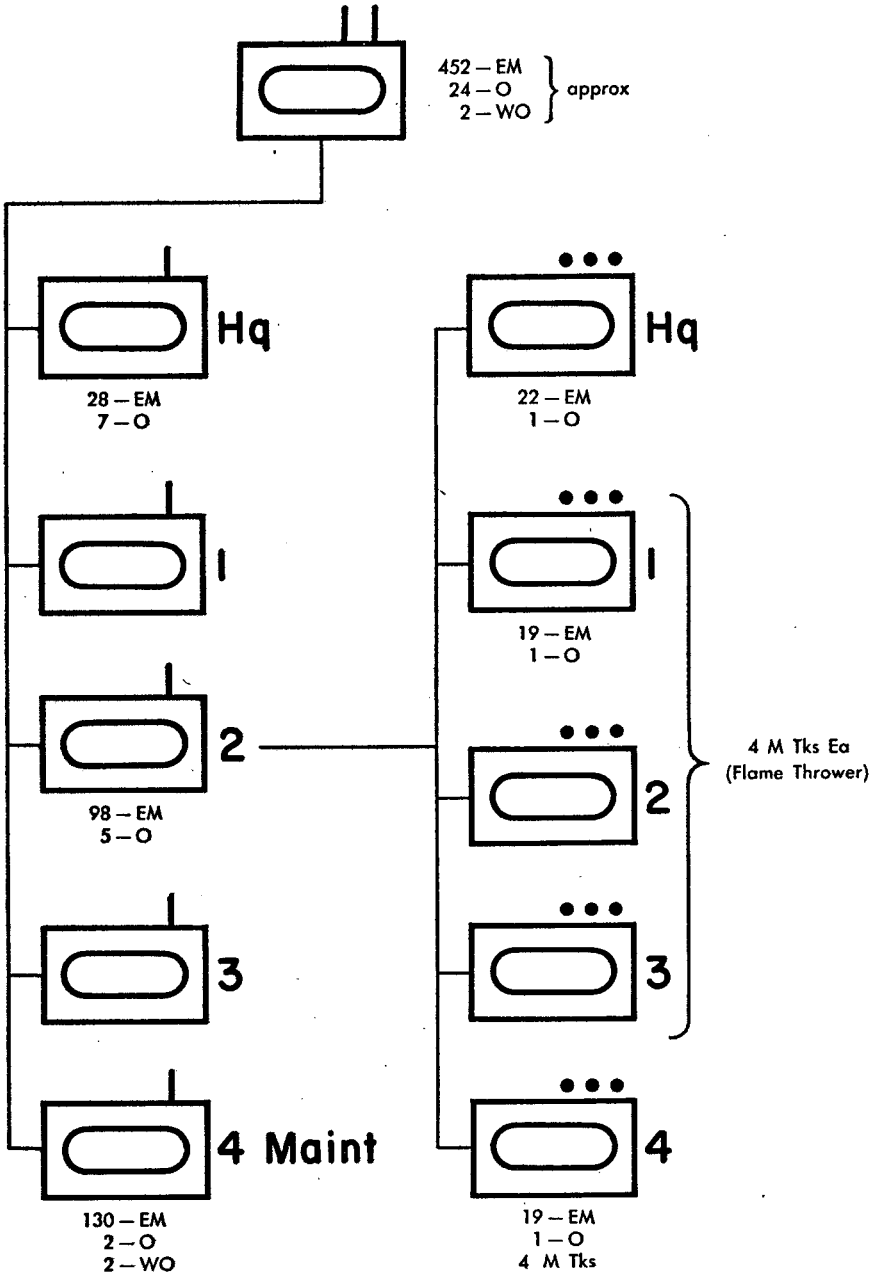

Figure 37. Flame thrower battalion.

gun regiment of the infantry and cavalry divisions. Consists of 3 batteries of 4 guns each. T/O strength of approximately 424.

(b) *75-mm gun battalion, 2-battery type* (fig. 18). One in the 75-mm gun regiment of the infantry and cavalry division. Consists of 2 batteries of 4 guns each. T/O strength of approximately 284.

(c) *75-mm gun battalion, truck-drawn* (fig. 32). Three in the truck-drawn 75-mm gun regiment of the motorized and mechanized divisions. Consists of three batteries of 4 guns each. T/O strength of approximately 409.

(d) *75-mm gun battalion, airborne division* (fig. 25). One in each airborne division headquarters (fig. 24). Consists of three batteries of eight 75-mm guns each. T/O strength of approximately 746.

(e) *Mixed artillery battalion, airborne brigade* (fig. 24). One in each airborne brigade. Consists of two 75-mm gun batteries of 4 guns each, and a 120-mm mortar battery containing 4 mortars. T/O strength of approximately 214.

(f) *120-mm howitzer battalion, 2-battery type* (fig. 18). One in the 120-mm howitzer regiment of the artillery brigade of the infantry division. Consists of 2 batteries of 4 howitzers each. T/O strength of approximately 306.

(g) *120-mm howitzer battalion, 3-battery type* (fig. 18). One in the 120-mm howitzer regiment of the artillery brigade of the infantry division. Consists of 3 batteries of 4 howitzers each. T/O strength of approximately 460.

(h) *120-mm howitzer battalion, 4-battery type* (fig. 30). Two in each 120-mm howitzer regiment of the artillery division. Consists of 4 batteries of 4 howitzers each. T/O strength of approximately 600.

(i) *150-mm gun/howitzer battalion* (fig. 30). Three in each 150-mm gun/howitzer regiment of the artillery division. Consists of three batteries of 2 gun/howitzers each. T/O strength of approximately 268.

(4) *Artillery batteries*. Found in all types of artillery battalions, the self-propelled artillery regiment, and as separate batteries in the infantry regiment, the cavalry regiment, and the light infantry battalion. There are eight types of artillery batteries.

(a) *Standard 75-mm gun battery*. Found in all battalions of the 75-mm gun regiments and in the cavalry regimental headquarters. It is organized exactly the same as the 75-mm howitzer battery of the infantry regiment (fig. 15), but contains 75-mm guns instead of 75-mm howitzers. Consists of four gun platoons, one ammunition and supply platoon, and a headquarters section. T/O strength of approximately 115-EM and 5-O.

(b) *75-mm gun battery, airborne division headquarters* (fig. 25). Three in the airborne artillery battalion of the airborne division headquarters. Consists of four gun platoons each containing two 75-mm guns, an ammunition and supply platoon, and a headquarters section.

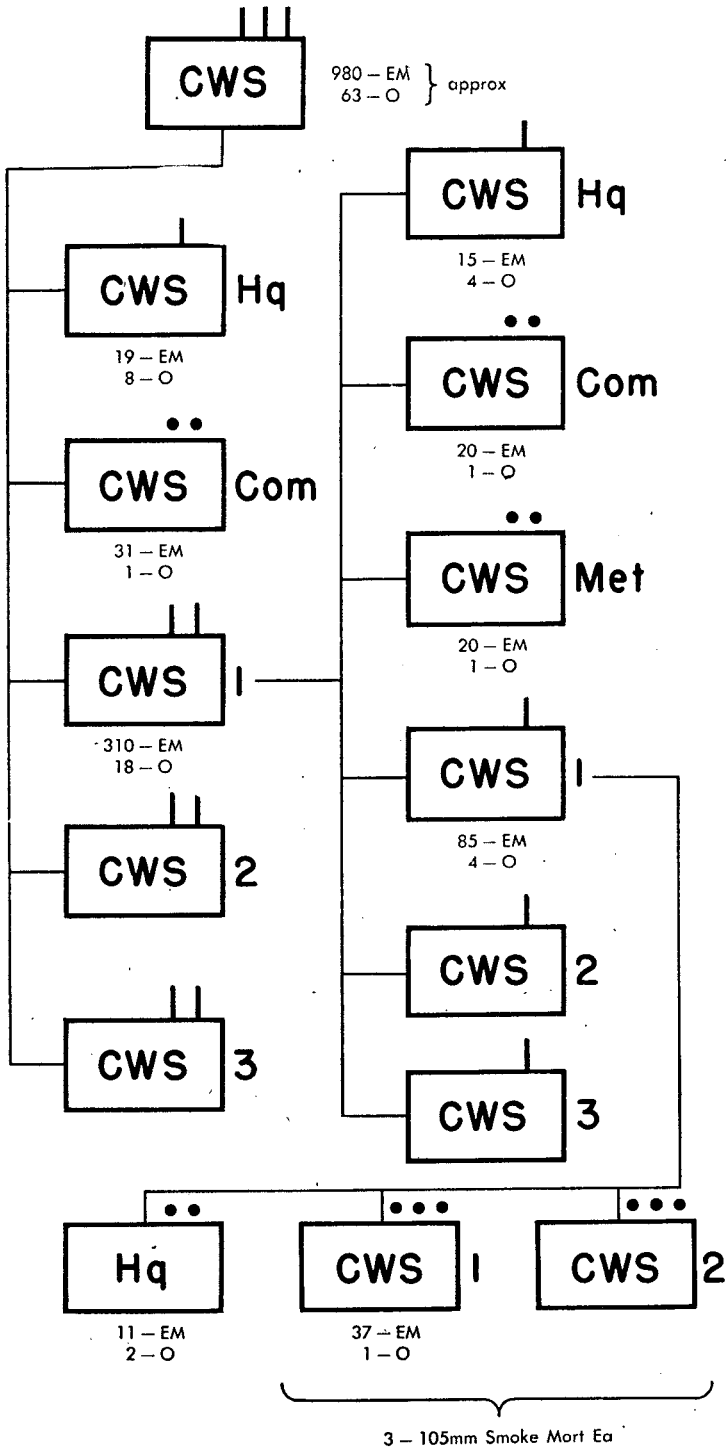

Figure 38. Chemical warfare service regiment (smoke).

Contains eight 75-mm guns and has a T/O strength of approximately 230-EM and 9-O.

(c) *75-mm gun battery, airborne brigade* (fig. 24). Two in the mixed airborne artillery battalion of the airborne brigade. Each battery contains four 75-mm guns and has a T/O strength of approximately 60-EM and 3-O.

(d) *75-mm gun battery, light division* (fig. 23). One in each of the eight light infantry battalions of the light division. Consists of two gun platoons containing two 75-mm guns each, an ammunition platoon, and a headquarters platoon. T/O strength of approximately 122-EM, 4-O, and 1-WO (*Am Plat*).

(e) *75-mm howitzer battery, infantry regiment* (fig. 15). One in each of the three infantry regiments of the infantry and motorized divisions. Consists of four howitzer platoons, an ammunition and supply platoon, and a headquarters section. T/O strength of approximately 115-EM and 5-O. Same organization as the standard 75-mm gun battery.

(f) *120-mm howitzer battery* (fig. 19). Found in the 120-mm howitzer regiments of the infantry and artillery divisions. Consists of four howitzer platoons, an ammunition and supply platoon, and a headquarters section. T/O strength of approximately 125-EM and 5-O.

(g) *150-mm gun/howitzer battery* (fig. 30). Three in each battalion of the 150-mm gun/howitzer regiments of the artillery division. Contains two 150-mm gun/howitzers and has a T/O strength of 70-EM and 4-O.

(h) *Self-propelled artillery battery* (fig. 33). Four in each self-propelled artillery regiment. Same organization for 80-mm, 120-mm, and 150-mm guns. Consists of one gun section containing 3 SP guns, one gun section containing 2 SP guns, and a headquarters section. Each battery contains 5 SP guns and has a T/O strength of approximately 67-EM and 4-O.

(5) *Mortar brigade* (fig. 30). One in each artillery division. Consists of three 120-mm mortar regiments of two battalions each, three batteries to each battalion. There are six 120-mm mortars in each battery, and a total of 108 for the brigade. T/O strength of approximately 2,068.

(6) *Mortar regiments*. Found in the artillery brigade of the infantry division (fig. 18), the mortar brigade of the artillery division (fig. 30), and in the armored and mechanized divisions. Although they all contain 120-mm mortars only, there are two different types due to mortar groupings: the 4-mortar battery type, and the 6-mortar battery type.

(a) *120-mm mortar regiment, 4-mortar battery type* (fig. 18). One in the artillery brigade of the infantry division, and in the armored and mechanized divisions. Consists of two battalions, one battalion containing three 120-mm mortar batteries, and the other having two 120-mm mortar batteries. Each battery (fig. 20) contains four 120-mm mortars, there being a total of 20 mortars in the entire regiment. T/O strength of approximately 448.

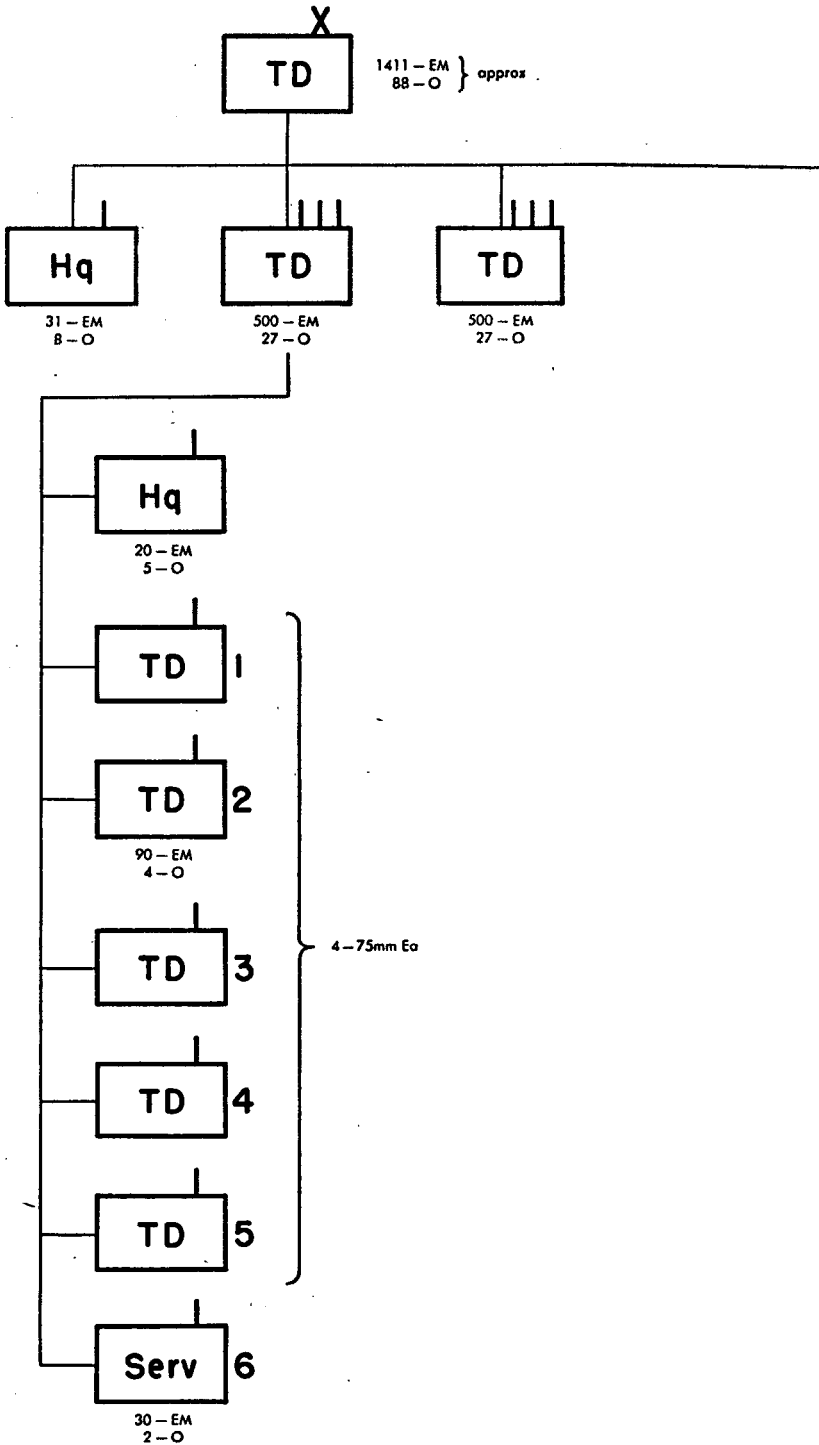

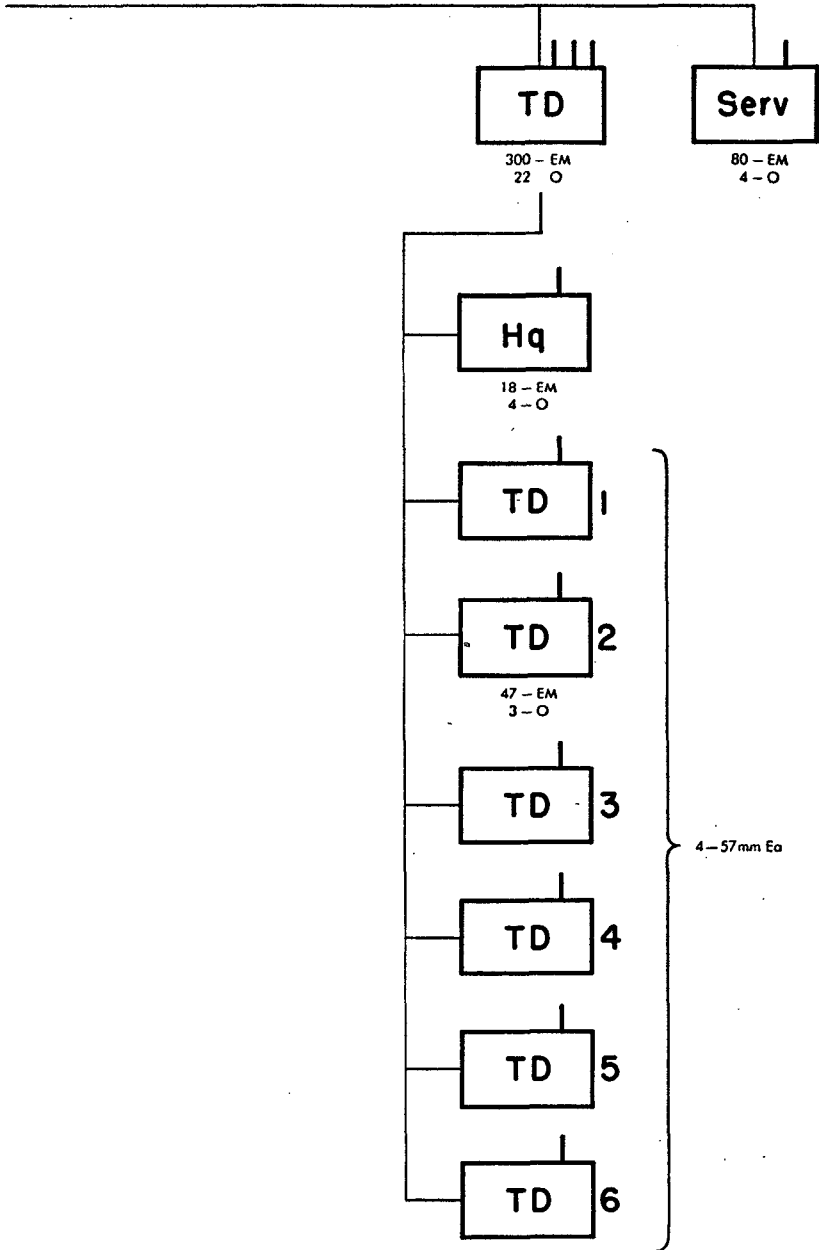

Figure 39. Tank destroyer brigade.

(b) *120-mm mortar regiment, 6-mortar battery type* (fig. 30). Three in the mortar brigade of the artillery division. Consists of two battalions of three batteries each, 6 *120-mm mortars* to the battery (fig. 13). Contains a total of 36 *120-mm mortars* and has a T/O strength of approximately 664.

(7) *Mortar battalions*. Two in each type of mortar regiment, and two in each of the three mechanized infantry regiments of the mechanized division (fig. 26). There are four types of mortar battalions, due mainly to mortar and battery groupings.

(a) *120-mm mortar battalion, 4-mortar 2-battery type* (fig. 18). One in the 120-mm mortar regiment of the artillery brigade of the infantry division, and the 120-mm mortar regiment of the armored and mechanized divisions. Consists of two mortar batteries of four 120-mm mortars each. T/O strength of approximately 153-EM and 10-O.

(b) *120-mm mortar battalion, 4-mortar 3-battery type* (fig. 18). One in the 120-mm mortar regiment of the artillery brigade of the infantry division, and the 120-mm mortar regiment of the armored and mechanized divisions. Consists of three batteries of four 120-mm mortars each. T/O strength of approximately 224-EM and 13-O.

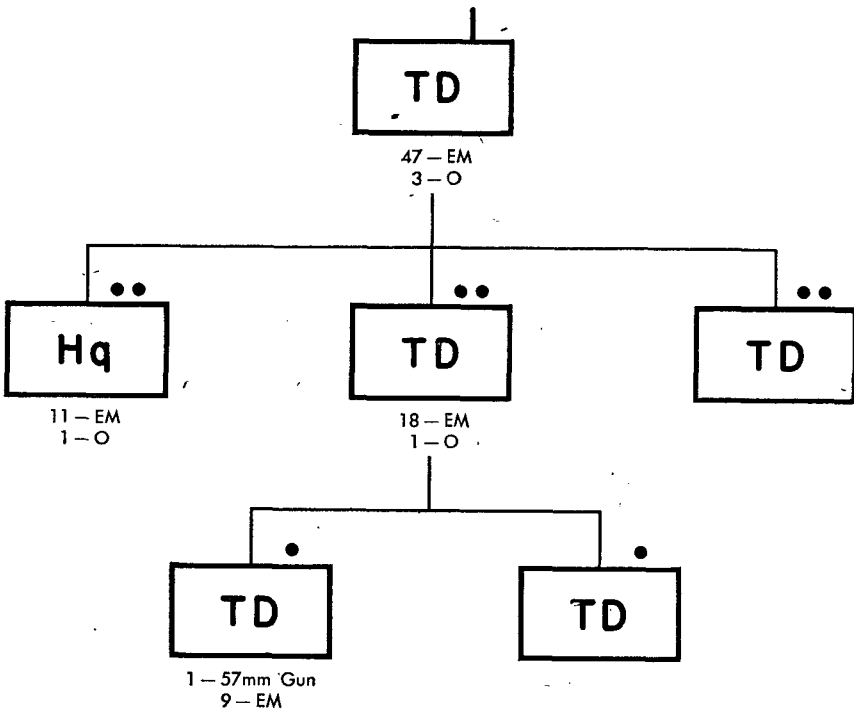

Figure 40. 57-mm. tank destroyer company, tank destroyer brigade.

(c) *120-mm mortar battalion, 6-mortar 3-battery type* (fig. 30). Two in each of the three 120-mm mortar regiments of the artillery division. Consists of three batteries of six 120-mm mortars each. T/O strength of approximately 288-EM and 20-O.

(d) *Mixed mortar battalion* (fig. 13). Two in each of the three mechanized infantry regiments of the mechanized division. Consists of two 81-mm mortar batteries, one 120-mm mortar battery, and a headquarters battery. Each battery contains 6 mortars. T/O strength of approximately 228-EM and 17-O.

(8) *Mortar batteries and companies*. Found as a mortar battery in all types of mortar battalions and in the cavalry regiments of the cavalry division (fig. 31); found as a separate mortar company in the regimental headquarters and infantry battalions of the infantry regiment (fig. 12) and in the parachute infantry battalion (fig. 24). There are seven types of these units.

(a) *50-mm mortar battery* (fig. 31). One in each cavalry regiment. Consists of three platoons of four 50-mm mortars each. T/O strength of approximately 145-EM, 6-O, and 2-WO (*Am and Sup Plat*).

(b) *50-mm mortar company* (fig. 24). One in each parachute infantry battalion. Consists of three platoons of two 50-mm mortars each. T/O strength of approximately 46-EM and 4-O.

(c) *81-mm mortar battery* (fig. 26). Two in each mortar battalion of the mechanized infantry regiment. Consists of three platoons of two 81-mm mortars each. T/O strength of approximately 61-EM and 4-O.

(d) *81-mm mortar company* (fig. 12). One in each standard infantry battalion. Consists of three platoons of two 81-mm mortars each. T/O strength of approximately 47-EM and 4-O.

(e) *120-mm mortar battery, 4-mortar type* (fig. 20). Found in the 120-mm mortar regiment of the infantry division, the armored division, and the mechanized division, and in the mixed airborne artillery battalion of the airborne brigade. Consists of two platoons of two 120-mm mortars each. T/O strength of approximately 66-EM and 3-O.

(f) *120-mm mortar battery, 6-mortar type* (fig. 13). Three in each battalion of the 120-mm mortar regiments of the artillery division, and one in each of the mixed mortar battalions of the mechanized infantry regiments. Consists of three platoons of two 120-mm mortars each. T/O strength of approximately 84-EM and 5-O.

(g) *120-mm mortar company* (fig. 14). One in each standard infantry regiment of the infantry and motorized divisions. Consists of three platoons of three 120-mm mortars each, an ammunition and supply platoon, and a headquarters section. T/O strength of approximately 145-EM and 5-O.

(9) *Antitank regiments*. Found in the infantry, motorized, and mechanized divisions. There are two types: 57-mm and 105-mm.

(a) *57-mm antitank regiment* (fig. 21). One in each motorized division. Consists of two battalions, one battalion having three 57-mm antitank companies and the other having two 57-mm antitank companies. There are 4 guns in each company, making a total of 20 for the regiment. T/O strength of approximately 467.

(b) *105-mm antitank regiment* (fig. 11). One in each infantry and mechanized division. Consists of two battalions, one battalion having three 105-mm antitank companies, and the other having two 105-mm antitank companies. There are 4 guns in each company, making a total of 20 for the regiment. T/O strength of approximately 785.

(10) *Antitank battalions*. Found in the antitank regiments of the infantry, motorized, and mechanized divisions, and as a separate battalion in the airborne brigade. There are five types, due to the irregular grouping of the companies in the battalions of the 57-mm and 105-mm antitank regiments.

(a) *57-mm antitank battalion, 2-company type* (fig. 21). One in the antitank regiment of the motorized division. Consists of two companies, each containing four 57-mm antitank guns. T/O strength of approximately 161-EM and 10-O.

(b) *57-mm antitank battalion, 3-company type* (fig. 21). One in the antitank regiment of the motorized division. Consists of three companies, each containing four 57-mm antitank guns. T/O strength of approximately 239-EM and 13-O.

(c) *75-mm antitank battalion* (fig. 24). One in each airborne brigade. Consists of four companies, each containing four 75-mm antitank guns. T/O strength of approximately 252-EM and 16-O.

(d) *105-mm antitank battalion, 2-company type* (fig. 11). One in the antitank regiment of the infantry and mechanized divisions. Consists of two companies, each containing four 105-mm antitank guns. T/O strength of approximately 267-EM and 16-O.

(e) *105-mm antitank battalion, 3-company type* (fig. 11). One in the antitank regiment of the infantry and mechanized divisions. Consists of three companies, each containing four 105-mm antitank guns. T/O strength of approximately 397-EM and 21-O.

(11) *Antitank companies*. Found in the antitank battalions of the infantry, motorized, airborne, and mechanized divisions, and as a separate company in the infantry battalion of the standard infantry regiments of the infantry and motorized divisions. There are four types.

(a) *57-mm antitank company* (fig. 21). Five in the antitank regiment of the motorized division. Contains four 57-mm antitank guns and has a T/O strength of 72-EM and 3-O.

(b) *75-mm antitank company, standard infantry battalion* (fig. 16). Consists of four 75-mm antitank platoons, an ammunition and supply platoon, and a headquarters section. Contains four 75-mm antitank guns and has a T/O strength of approximately 115-EM and 5-O.

(c) *75-mm antitank company, airborne division* (fig. 24). Four in the antitank battalion of each airborne brigade. Contains four 75-mm antitank guns and has a T/O strength of approximately 60-EM and 3-O.

(d) *105-mm antitank company* (fig. 11). Five in the antitank regiment of infantry and mechanized divisions. Organized same as the 120-mm howitzer battery of the artillery brigades (fig. 19). Contains four 105-mm antitank guns and has a T/O strength of 125-EM and 5-O.

(12) *Antiaircraft regiment* (fig. 11). One in each infantry and mechanized division. Consists of three batteries of two platoons each, three 40-mm antiaircraft guns to a platoon. Contains a total of 18 40-mm antiaircraft guns and has a T/O strength of approximately 480.

(13) *Antiaircraft battalion* (fig. 24). One in each airborne brigade of the airborne division. Consists of three batteries, two containing 12 20-mm antiaircraft guns and the third containing 11 40-mm antiaircraft guns. T/O strength of approximately 566.

(14) *Antiaircraft batteries*. Found in the antiaircraft regiment of the infantry and mechanized divisions, the antitank battalion of the airborne brigade, and as a separate battery in the cavalry division headquarters. There are three types.

(a) *20-mm antiaircraft battery* (fig. 24). Two in the antiaircraft battalion of the airborne brigade. Contains 12 20-mm antiaircraft guns and has a T/O strength of approximately 150-EM and 6-O.

(b) *40-mm antiaircraft battery, 6-gun type* (fig. 11). Three in the antiaircraft regiment of the infantry and mechanized divisions, and one in the cavalry division. Consists of two platoons of three 40-mm antiaircraft guns each and has a T/O strength of approximately 142-EM and 4-O.

(c) *40-mm antiaircraft battery, 11-gun type* (fig. 24). One in the antiaircraft battalion of the airborne brigade. Contains 11 40-mm antiaircraft guns and has a T/O strength of approximately 210-EM and 7-O.

(15) *Rocket battalion* (fig. 41). One in each motorized and mechanized division. Consists of two rocket batteries and a headquarters battery. Each of the rocket batteries contains five 150-mm rocket launchers, making a total of 10 for the battalion. T/O strength of approximately 334.

(16) *Survey battalion* (fig. 30). One in each artillery division. Consists of two sound batteries, a flash battery, a survey battery, a photo battery, and a headquarters battery. T/O strength of approximately 300-EM and 17-O.

b. Non-divisional artillery units. GHQ artillery units include tank destroyer brigades, mortar brigades, heavy and super-heavy artillery battalions, self-propelled artillery battalions, rocket battalions, antiaircraft battalions, railway artillery battalions, survey and mapping battalions, meteorological platoons, observation battalions, and observation balloon batteries; of these, organizational charts are available only for the tank

destroyer brigade (fig. 39). Corps troops artillery units normally organic to each corps are the air observation post squadrons (fig. 35) and the survey regiments (fig. 34). These three units are discussed below.

(1) *Tank destroyer brigade* (fig. 39). Consists of three tank destroyer regiments; two containing five tank destroyer companies of four 75-mm guns each, and the third containing six tank destroyer companies of four 57-mm guns each. The brigade has a total of 40 75-mm guns and 24 57-mm guns. T/O strength of approximately 1,499.

(2) *Tank destroyer regiments*. Three in the tank destroyer brigade. There are two types: 57-mm and 75-mm.

(a) *57-mm tank destroyer regiment* (fig. 39). One in each tank destroyer brigade. Consists of six 57-mm tank destroyer companies (fig. 40) and a headquarters company. Each tank destroyer company

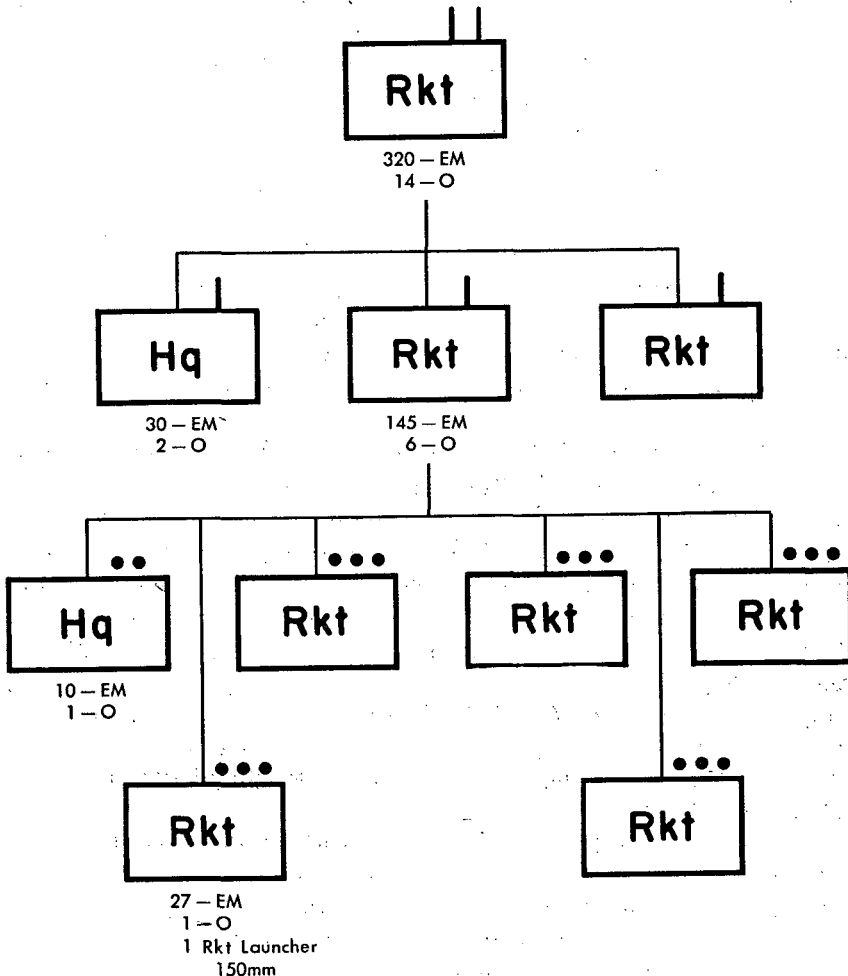

Figure 41. Rocket battalion.

contains four 57-mm guns, making a total of 24 for the regiment. T/O strength of approximately 322.

(b) *75-mm tank destroyer regiment* (fig. 39). Two in each tank destroyer brigade. Consists of five 75-mm tank destroyer companies, a service company, and a headquarters company. Each tank destroyer company contains four 75-mm guns, making a total of 20 in the regiment. T/O strength of approximately 527.

(3) *Tank destroyer companies*. Found in the regiments of the tank destroyer brigade. There are two types: 57-mm and 75-mm.

(a) *57-mm tank destroyer company* (fig. 40). Six in the 57-mm tank destroyer regiment of the tank destroyer brigade. Consists of two gun sections of two guns each, and a headquarters section. T/O strength of approximately 47-EM and 3-O.

(b) *75-mm tank destroyer company* (fig. 39). Five in each of the two 75-mm tank destroyer regiments of the tank destroyer brigade. Has two gun sections of two guns each as in the 57-mm tank destroyer company (fig. 40), but also contains an ammunition and supply section in addition to a headquarters section. No organizational chart is available for this company. T/O strength of approximately 90-EM and 4-O.

(4) *Survey regiment* (fig. 34). One normally organic to each corps. Consists of two survey battalions and a headquarters battery. Each of the two battalions contains an observation battery, a sound ranging battery, a survey battery, and a headquarters battery. T/O strength of approximately 583.

(5) *Survey battalion* (fig. 34). Two in each corps survey regiment. Consists of an observation battery, a sound ranging battery, a survey battery, and a headquarters battery. T/O strength of approximately 245-EM and 15-O.

(6) *Air observation post squadron* (fig. 35). One normally organic to each corps. Consists of four air observation post flights of four liaison-type planes each. Contains a total of 16 liaison-type planes and has a T/O strength of approximately 450.

(7) *Air observation post flight* (fig. 35). Four in each corps air observation post squadron. Contains four liaison-type planes and has a T/O strength of approximately 88-EM and 6-O.

44. ENGINEERS. This branch includes all the engineer units of divisions down to platoon level, and all the GHQ and Corps troops specialized engineer units.

a. Divisional engineer units. (1) *Engineer companies*. Found in all types of divisions, except artillery. Except for those in the light division, they have the same organization.

(a) *Standard engineer company* (fig. 11). One in each infantry, motorized, armored, mechanized, and cavalry division, and each of the airborne brigades of the airborne division. Consists of a ponton platoon;

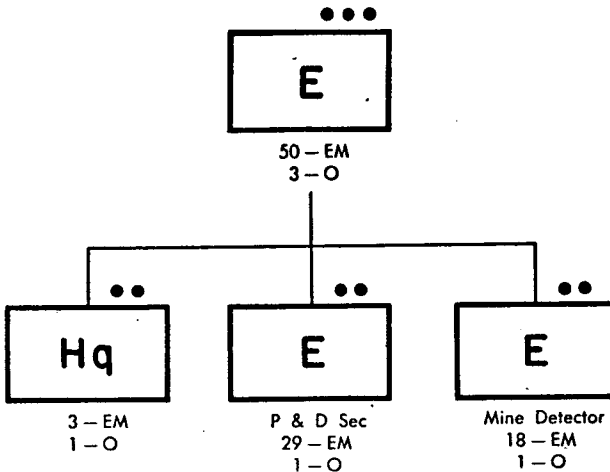

Figure 42. Engineer platoon, infantry regiments and armored infantry battalions.

a bridge building platoon, a mine laying platoon, and a headquarters section. T/O strength of approximately 190-EM and 5-O.

(b) *Engineer company, light division* (fig. 22). One in each light division. Consists of one ponton platoon, two bridge building platoons, a mine laying platoon, a maintenance platoon, and a headquarters platoon. T/O strength of approximately 250-EM and 7-O.

(2) *Engineer platoon, separate* (fig. 42). One in the regimental headquarters of standard mechanized infantry regiment, and in the armored infantry battalions of the armored and mechanized divisions. Consists of one pioneer and demolition section, a mine detector section, and a headquarters section. T/O strength of approximately 50-EM and 3-O.

b. Non-divisional engineer units. (1) There are no organizational charts available for any of these units, but it is known that there are GHQ engineer battalions, bridge construction battalions, road construction battalions, prisoner of war labor battalions, mine detection companies, and demolition detachment. An engineer regiment is normally organic to each corps. No chart is available, but some details of its organization are given below.

(2) *Engineer regiment.* Consists of three engineer companies, a service company, and a headquarters company. The strength of the field company is about 250 and performs normal engineer work. The service company contains, in addition to a supply section, a repair shop and bridging section.

45. SIGNAL CORPS. This branch includes all the signal troops of the divisions down to and including platoon level, and all the special GHQ signal units, and the corps signal battalion.

a. **Divisional signal units.** (1) *Signal battalion* (fig. 43). One in each artillery division. Consists of three signal companies and a headquarters company. T/O strength of approximately 483.

(2) *Signal company* (figs. 22 and 43). Found in the signal battalion of the artillery division and as a separate company in all other types of divisions; each tank regiment also contains a signal company. Consists of two wire platoons, a radio platoon, a maintenance platoon, and a headquarters section. T/O strength of approximately 140-EM, 5-O, and 2-WO (*Maint Plot*).

(3) *Signal platoon, separate* (fig. 44). Found in each of the three mechanized infantry regimental headquarters of the mechanized division,

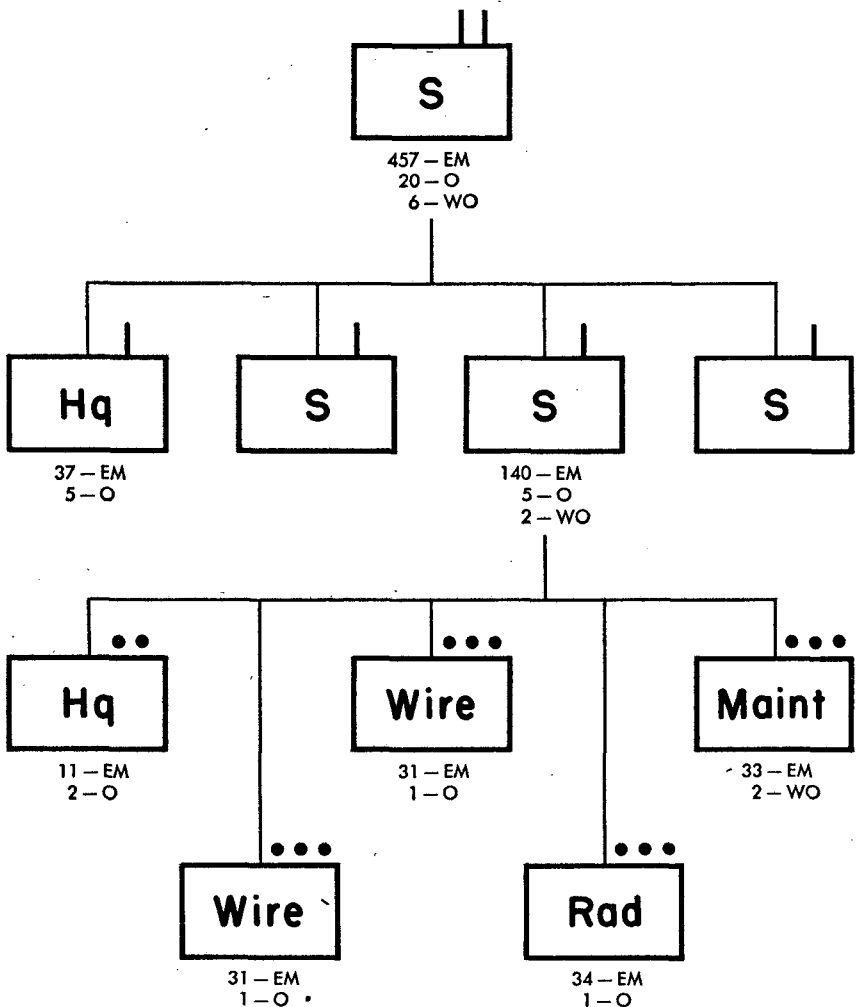

Figure 43. Signal battalion.

the headquarters of the standard infantry regiment, and the parachute infantry battalion of the airborne brigade. Consists of one wire section of two squads, a headquarters section, a radio squad, and a maintenance squad. T/O strength of approximately 50-EM and 5-O.

b. Non-divisional signal units. (1) These include signal battalions or regiments and radio intercept battalions. One signal battalion is normally organic to each corps. No organizational chart is available, but some details of its organization are given below.

(2) *Signal battalion.* Consists of two signal companies and a headquarters company. One is a construction company, and the other a radio company.

46. CHEMICAL WARFARE SERVICE. There are no divisional units, but GHQ chemical units include both chemical and scientific warfare units.

a. Divisional chemical units. None.

b. Non-divisional chemical units. Include smoke regiments, separate smoke battalions, decontamination battalions, flame throwing battalions, and bacteriological companies. Smoke battalions have been identified, usually as GHQ troops sub-allotted to a corps headquarters in the field. The only organizational chart available is for the smoke regiment.

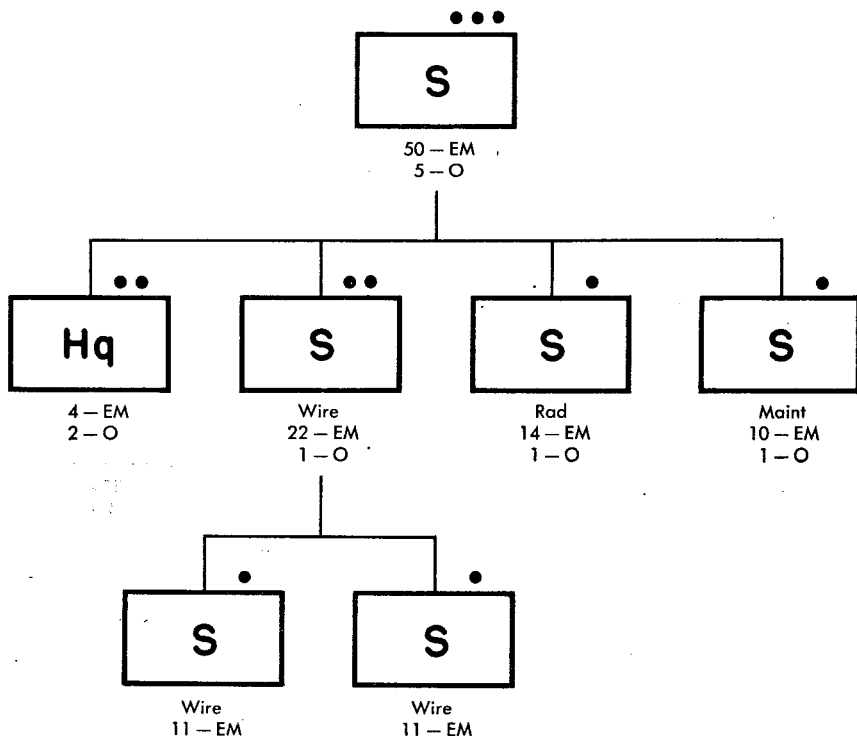

Figure 44. Signal platoon, infantry regiments, and parachute infantry battalion.

(1) *Smoke regiment* (fig. 38). Consists of three smoke battalions, a headquarters company, and a communications section. Each smoke battalion contains three companies each equipped with 6 105-mm smoke mortars, making a total of 54 105-mm smoke mortars in the regiment. T/O strength of approximately 1,043.

(2) *Smoke battalion*. Three in each smoke regiment; also found as separate battalions in corps headquarters. The regimental smoke battalion consists of three smoke companies of six 105-mm smoke mortars each, a headquarters company, a communications section, and a meteorological section. T/O strength of approximately 328.

(3) *Smoke company*. Found in all types of smoke battalions. Three in each smoke battalion of the smoke regiment. This latter consists of two smoke platoons each containing three 105-mm smoke mortars, and a headquarters section. T/O strength of approximately 85-EM and 4-O.

47. PROPAGANDA TROOPS. These troops consist mainly of news reporters, photographers, film cameramen, and radio commentators. Their main function is front line reporting, but they also conduct propaganda addressed to the enemy, as well as to the Aggressor troops.

a. **Divisional propaganda units.** None.

b. **Non-divisional propaganda units.** One propaganda company assigned to each army in the field. No further details of its organization are known.

Section IX. SERVICE TROOPS

48. GENERAL. Every Aggressor division includes in its organic components the divisional services which vary in strength in accordance with the size and type of division. The divisional services of all types of divisions, however, are organized on the basis of the same standard pattern and include the following elements:

Quartermaster	Military police
Medical	Finance
Ordnance	Field post office

These are usually grouped in either service battalions or companies, but the medical corps and quartermaster corps have separate units in some types of divisions. Maintenance troops belong to the branch of service of the division or divisional component unit in which they are found, and are not considered as service troops. Only veterinary units of the light division have been identified, but it is known that they are present in the cavalry division and in the Aggressor homeland at remount service stations. Figures 45 to 51 show all the known organization charts for the service troops.

49. SERVICE UNITS. These units do not constitute a separate branch of service, but are grouped together for administrative purposes and to

facilitate centralized control of the various service troops which make up the service company, battery, or battalion. They are found in all types of divisions, except the light division, where the service troops are not grouped together, but appear as separate units.

a. Divisional service units. (1) *Service battalions.* Found in all types of division, except light and armored divisions. There are three types: standard, and the ones found in the infantry division and the artillery division.

(a) *Standard service battalion* (fig. 46). Found in the motorized division, the airborne brigade of the airborne division, the mechanized infantry regiments of the mechanized division, and the cavalry division. Consists of a quartermaster company, an ordnance company, a finance platoon, a medical platoon, a postal section, and a headquarters company. T/O strength of approximately 476.

(b) *Service battalion, infantry division* (fig. 45). One in each infantry division. Consists of a quartermaster company, an ordnance company, a military police company, a medical platoon, a finance section, a postal section, and a headquarters company. T/O strength of approximately 583.

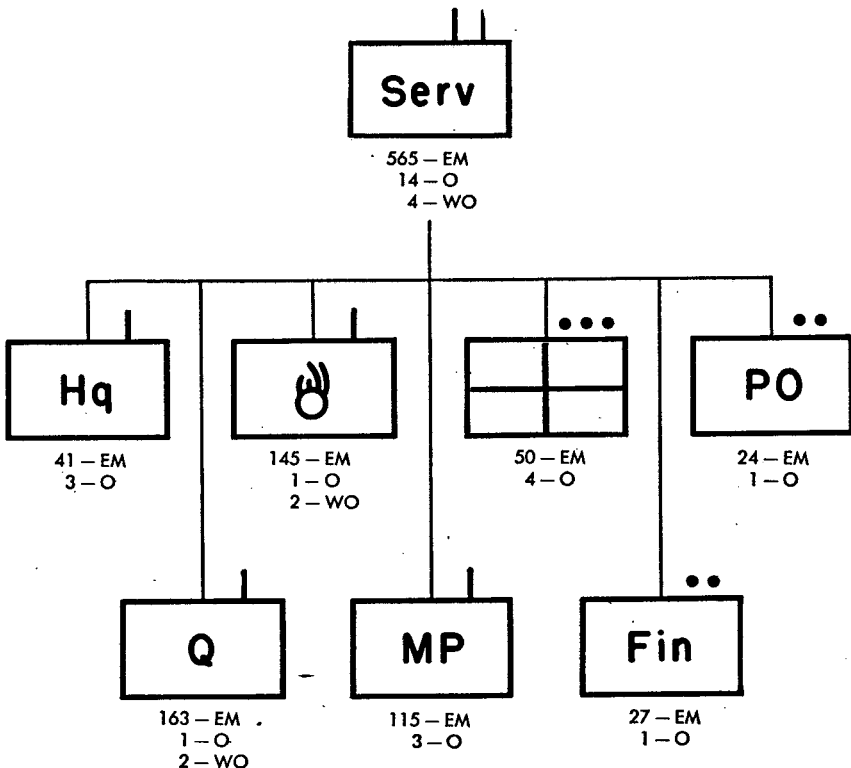

Figure 45. Service battalion, standard infantry division.

(c) *Service battalion, artillery division* (fig. 47). One in each artillery division. Consists of a quartermaster company, an ordnance company, a military police company, a medical company, a finance section, a postal section, and a headquarters company. T/O strength of approximately 842.

(2) *Service battery* (fig. 48). One in the artillery brigade of the infantry division. Consists of a quartermaster platoon, a maintenance platoon (artillery troops), an ordnance platoon, a medical platoon, and a headquarters section. T/O strength of approximately 160-EM, 2-O, and 2-WO.

(3) *Service company* (fig. 49). One in the armored and mechanized divisions. Consists of a quartermaster platoon, an ordnance platoon, a military police platoon, a medical platoon, a finance section, a postal section, and a headquarters section. T/O strength of approximately 270-EM, 4-O, and 4-WO.

b. *Non-divisional service units.* GHQ and Corps service troops do not appear in a service unit, but belong to the branch of service to which the unit belongs. GHQ service units include motor transport battalions (Quartermaster Corps), supply column battalions (Quartermaster Corps), motor maintenance and repair units (Ordnance), medical units including

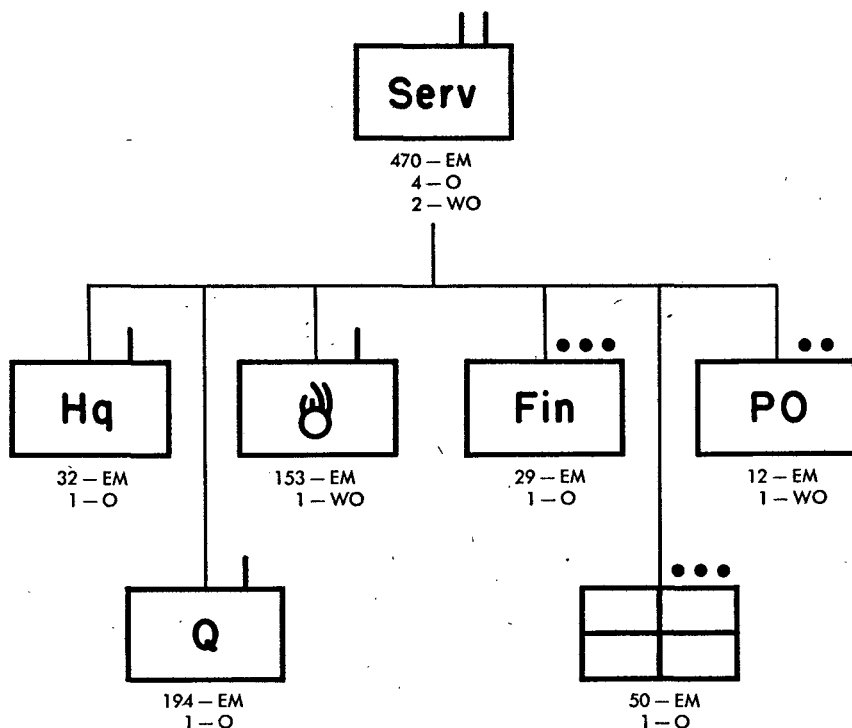

Figure 46. *Service battalion for the airborne brigade, motorized division, mechanized infantry regiment, or cavalry division.*

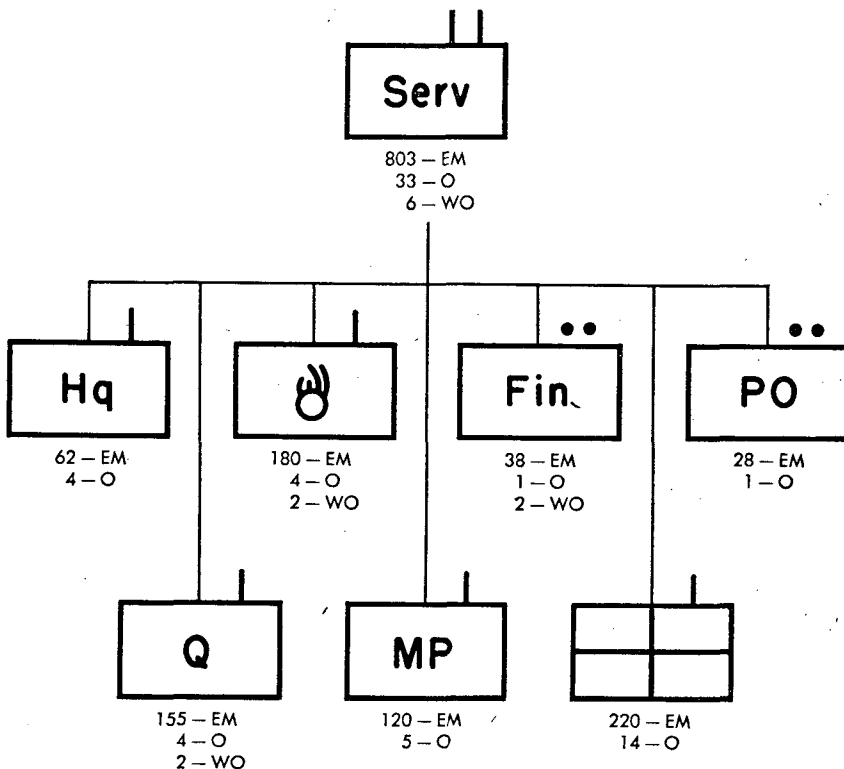

Figure 47. Service battalion, artillery division.

medical battalions, and veterinary units. In corps headquarters they appear as medical, quartermaster, ordnance, finance, military police, and postal detachments.

50. QUARTERMASTER CORPS. This branch includes all personnel engaged in the job of procuring, storing, and issuing items of quartermaster supply. Most personnel of this branch are on duty in supply bases and depots throughout Aggressor. Small units, however, form a part of divisional service units, and larger units act as GHQ and corps troops.

a. Divisional quartermaster units. (1) *Transportation battalion, horse-drawn* (fig. 22). One in each light division. Consists of three transportation companies and a headquarters company. Contains approximately 150 1½-ton trucks and 200 horses; has a T/O strength of approximately 521.

(2) *Transportation company, horse-drawn* (fig. 22). Three in the transportation battalion of the light division. There are approximately 50 1½-ton trucks and 65 horses in each company. Consists of three horse-drawn transportation platoons and a headquarters section. T/O strength of approximately 150-EM and 5-O.

(3) *Quartermaster company*. Found in all types of service battalions. Its T/O strength varies from 160 to 200. (See figs. 45, 46, and 47.)

(4) *Quartermaster platoon, separate*. Found as a separate platoon in the service battery (fig. 48) of the artillery brigade of the infantry division, and in the service company (fig. 49) of the mechanized and armored division headquarters. In the service battery, it has a T/O strength of approximately 61-EM and 1-WO; in the service company a T/O strength of approximately 38-EM and 1-WO.

b. Non-divisional quartermaster units. Includes motor transport battalions and supply column battalions in GHQ troops, units on duty at quartermaster bases and depots, and the corps troops quartermaster detachments.

51. ORDNANCE. This branch includes all personnel engaged in ordnance work or in motor maintenance and repair. Units of this branch are usually on duty in ordnance bases and depots, but there are a few field units in the GHQ and Corps troops units, in addition to small divisional units.

a. Divisional ordnance units. (1) *Ordnance company*. Found in all types of service battalions. Its T/O strength varies from approximately 150 to 185. (See figs. 45, 46, and 47.)

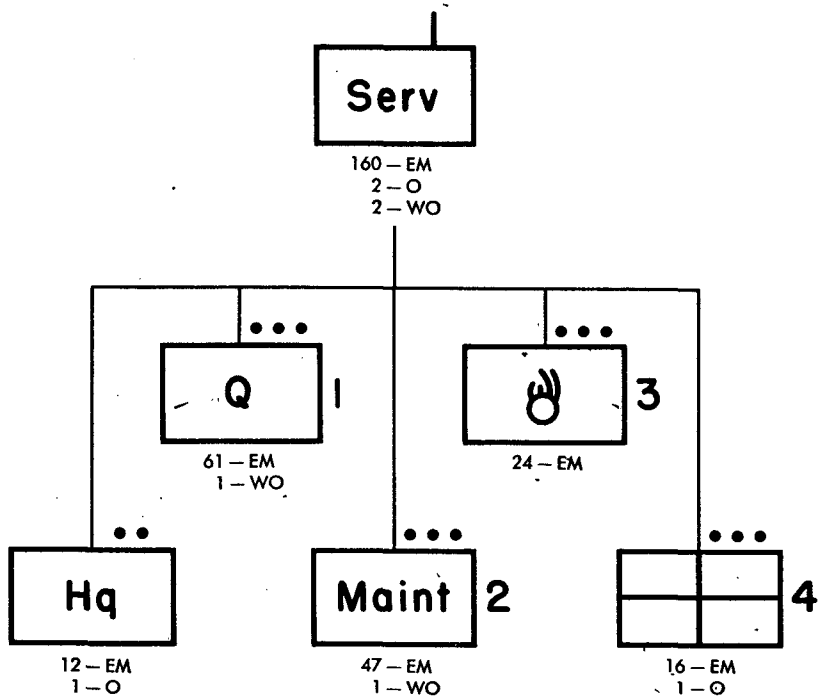

Figure 48. Service battery, artillery brigade.

(2) *Ordnance platoon, separate.* Found as a separate platoon in the service battery (fig. 48) of the artillery brigade of the infantry division, and in the service company (fig. 49) of the mechanized and armored division headquarters. T/O strength of approximately 24-EM in the service battery, and approximately 35-EM and 1-WO in the service company.

b. Non-divisional ordnance units. These include all the motor maintenance and repair units, the units on duty at ordnance bases and depots, and the corps headquarters ordnance detachments.

52. MEDICAL CORPS. Most of the personnel of this branch are on duty in hospitals and the divisional medical services. There are also some GHQ medical units, including medical battalions.

a. Divisional medical units. (1) *Medical battalion* (fig. 50). One in the light division and the airborne division. Consists of two companies, each company having four platoons. The battalion headquarters operates at division level, each company headquarters section at brigade level, and each of the eight platoons is attached to one of the eight infantry battalions. T/O strength of approximately 471.

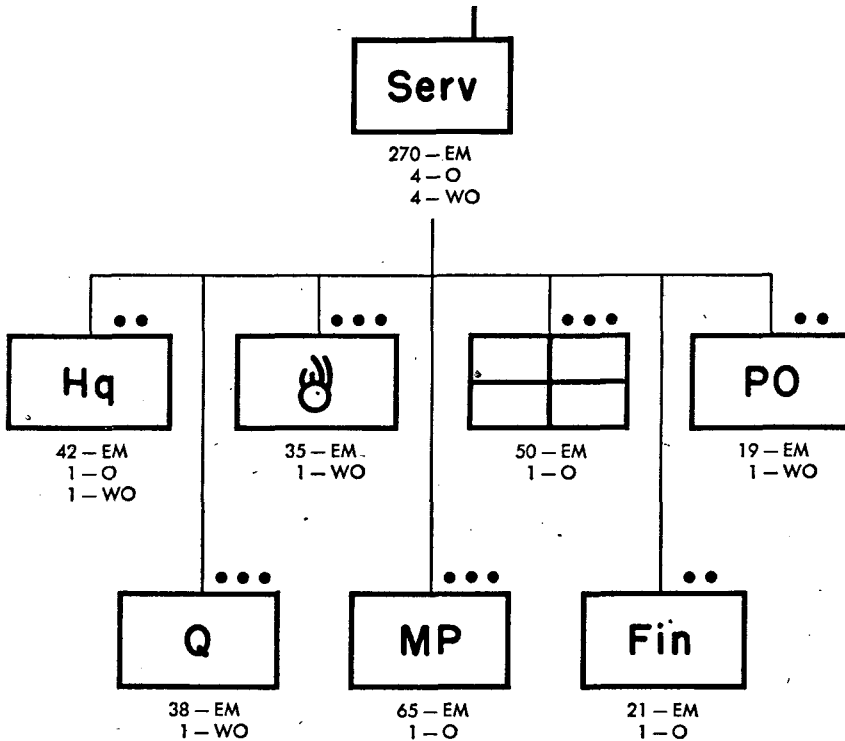

Figure 49. Service company, mechanized and armored divisions.

(2) *Medical company.* Found in the medical battalion of the light and airborne division (fig. 50) and as a separate company in the service battalion of the artillery division (fig. 47). The medical company of the medical battalion has four platoons and a headquarters section, and has a T/O strength of approximately 186-EM and 7-O, the separate medical company of the artillery division has a T/O strength of approximately 220-EM and 14-O.

(3) *Medical platoons.* Found in the medical companies of the medical battalion of the light and airborne divisions (fig. 50), and in the medical company of the service battalion of the artillery division (fig. 47); found as separate medical platoons in component units of all other types of division, and in the airborne brigade of the airborne division.

(a) *Medical platoon, medical company.* Has a T/O strength of approximately 40-EM and 1-O in the medical battalion of the light and airborne division (fig. 50); four platoons in each company, one for each of the four infantry battalion headquarters of the light or airborne brigade. No details are known of the organization of the medical platoon found in the medical company of the service battalion of the artillery division (fig. 47).

(b) *Medical platoon, separate.* Found in the airborne brigade of the airborne division, the regimental headquarters of the infantry regiments of the infantry and motorized divisions (fig. 51), in all service battalions except the service battalion of the artillery division (figs. 45 and 46), the service battery of the artillery brigade of the infantry division (fig. 48), and in the service company of the mechanized and armored divisions (fig. 49). It has a T/O strength of approximately 50, except in the service battery, where it contains only 16-EM and 1-O, and in the airborne brigade, where it contains 22-EM and 2-O.

b. Non-divisional units. Includes the GHQ medical battalions and other medical units, the hospital personnel at field bases and in Aggressor, and the Corps troops medical detachments.

53. VETERINARY SERVICE. This branch includes all personnel of the veterinary units. The only identified veterinary units at the present time are the veterinary platoons of the light divisions (fig. 22). GHQ veterinary units are known to exist in connection with the remount service, and it is also believed that veterinary units are present in the cavalry regiment of the cavalry division.

54. MILITARY POLICE. These include both the escort guards for prisoner of war companies and the traffic and discipline-control military police companies and platoons. Most of these are in duty in Aggressor, but there are small field units.

a. Divisional military police units. (1) *Military police company.* Found in the service battalions of the infantry division (fig. 45) and the artill-

lery division (fig. 47). In the latter, it has a T/O strength of approximately 120-EM and 5-O, and in the former a T/O strength of approximately 115-EM and 3-O.

(2) *Military police platoon, separate.* Found as a separate platoon in the service company of the armored and mechanized divisions (fig. 49). Has a T/O strength of 65-EM and 1-O.

b. Non-divisional military police units. Found as escort companies for prisoners of war, guarding prisoner of war installations in the Aggressor homeland, and in Corps troops military police detachments.

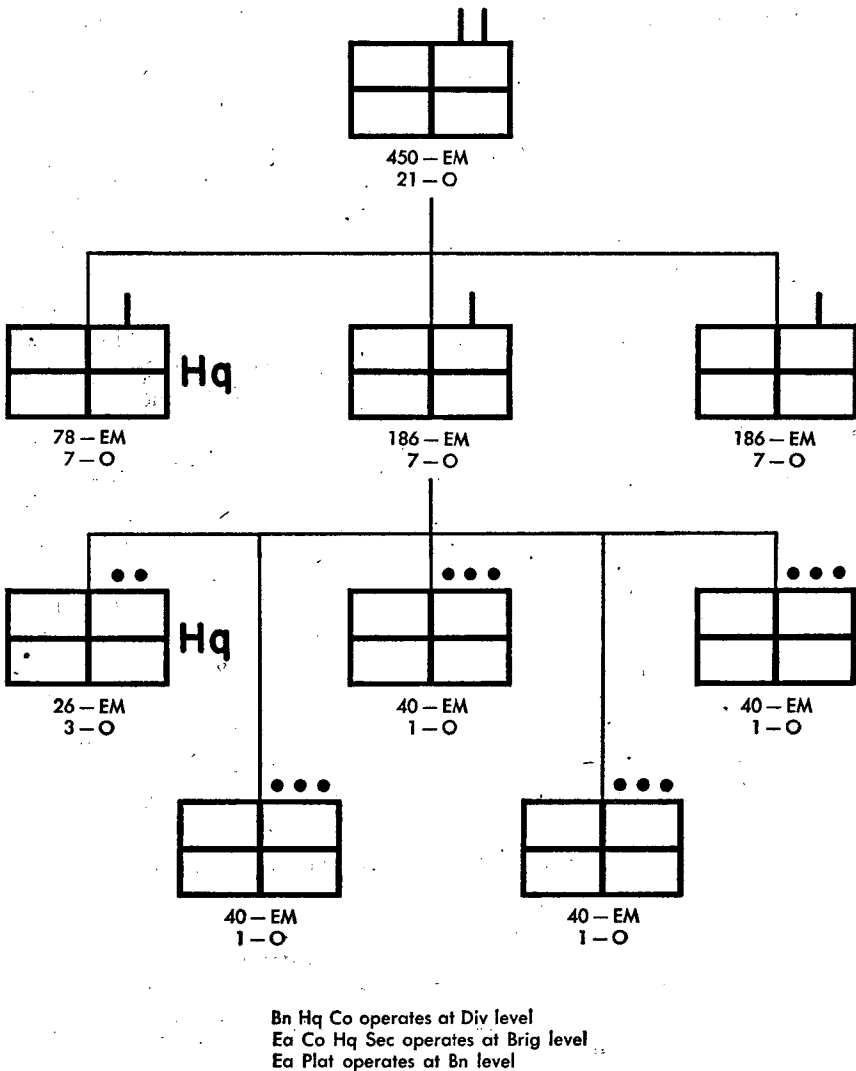
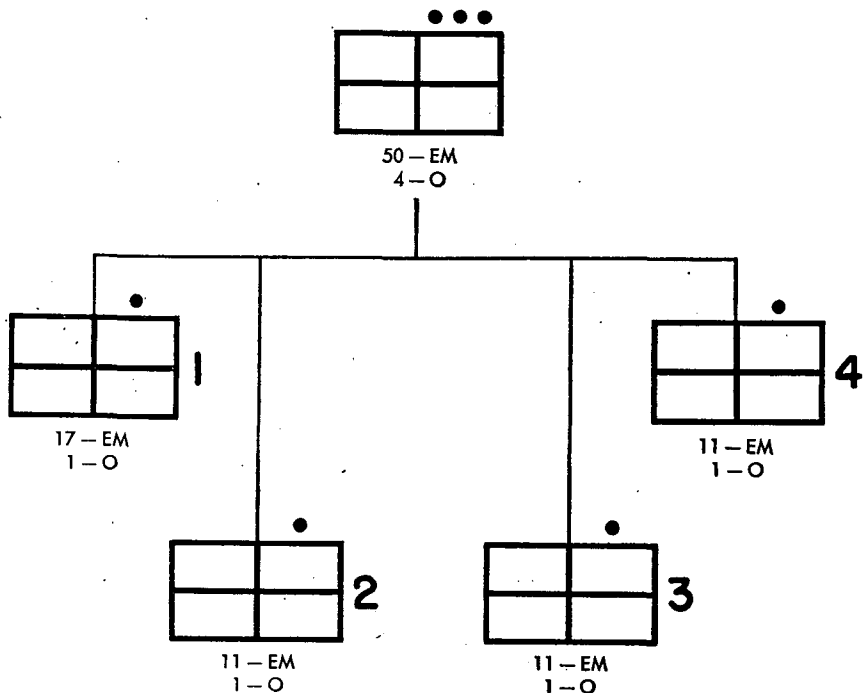

Figure 50. Medical battalion, light and airborne divisions.



#1 Sqd operates at Regtl level
 Sqds #2-3-4 operate at Bn level

Figure 51. Medical platoon, infantry regiment.

55. FINANCE DEPARTMENT. Consists of all personnel engaged in finance work in the army. Only small detachments appear in the field army; these are at all headquarters and in various divisional elements.

a. Divisional finance units. Found in all types of divisions in the service elements. Varies in size from approximately 20 to 40. (See figs. 45, 46, 47, and 49).

b. Non-divisional finance units. Found in finance detachments at the various headquarters.

56. POSTAL SERVICE. This branch includes the field post offices found in all types of divisions except the light division and in all headquarters in the field.

a. Divisional postal units. Found as a postal section in the service elements of all types of divisions except the light division. (See figs. 45, 46, 47, and 49.)

b. Non-divisional postal units. Found in all higher headquarters and in base stations in Aggressor.

CHAPTER 3OTHER MILITARY AND AUXILIARY ORGANIZATIONS

Section I. GENERAL

57. **GENERAL.** While it is known that certain para-military and auxiliary organizations exist for pre-military training, frontier control, home defense, bomb damage control, and policing the armed forces, details of these and others believed to exist are lacking. As more information is discovered concerning such organizations, the details on this new information will be disseminated to all concerned.

Section II. MINISTRY OF SECURITY AND PROPAGANDA

58. **GENERAL. a.** Capitalizing on the experiences of Germany and other totalitarian nations in World War II, the Aggressor nation has developed a highly effective organization called the Ministry of Security and Propaganda, operating directly under the Supreme Council, for "thought control" within Aggressor boundaries and for promoting Aggressor objectives all over the world by espionage, propaganda, and sabotage. Within the Armed Forces, members of this organization are known as "political advisers." All other activities are directed by the Bureau of Security, within which are two departments, one concerned with Aggressor's internal affairs and the other with the conduct of activities in foreign nations.

b. This foreign department is charged with the "political education" of foreign converts, general propaganda, schooling and selection of principal targets for saboteurs, and with the conduct of a secret espionage system, in addition to military espionage. It attempts to soften Aggressor's enemies by propaganda, promotes labor and interracial strife, provides Quislings and spies, sabotages essential war industry and key communication facilities, and provides saboteurs in the invaded country to work in close conjunction with the armed forces.

CHAPTER 4

TACTICS

Section I. TACTICAL DOCTRINES

59. BASIC DOCTRINES. Aggressor tactics in general conform closely to United States doctrine. The importance of the offensive is stressed in training, while the defense and withdrawal are included as measures to be employed when the offensive cannot be maintained. Certain technique varies slightly, and some practices receive more emphasis than in the United States Army. In the following pages, only points that are peculiar to Aggressor or receive considerable stress in training will be discussed.

60. COMMAND. The basic principle is unity of command at all levels. The commander is the senior officer of the primary mobile area; he is responsible not only for over-all success or failure but also for direct personal control of reconnaissance and operations in critical phases of combat.

61. COMBAT INTELLIGENCE. In the essential elements of information, the Aggressor Army stresses the importance of determining feasible approaches to the deep flanks and to the rear of the enemy main body.

62. RECONNAISSANCE AND OBSERVATION. Great stress is laid on thorough and carefully planned reconnaissance *which must be conducted without revealing the plan of attack*. Front line reconnaissance is performed by stealth using as few troops as possible. A reconnaissance in force has the mission of disclosing the fire plan, locating tactical reserves, and capturing prisoners. Prisoners are fully exploited and great importance is attached to their use. The air force assists the ground forces in all types of reconnaissance to include photo missions.

63. SIGNAL INTELLIGENCE. Radio intercept is well developed and extensively employed. Accurate radio-locator (radar and RDF) instruments are used. In static situations, signal patrols endeavor to tap enemy wire nets.

64. CAPTURED DOCUMENTS. All ranks are thoroughly indoctrinated with the importance of enemy documents. Documents are carefully exploited at all intelligence levels.

65. PRISONERS OF WAR. Aggressor is very conscious of the value of prisoners of war. Units are often directed to secure prisoners from specified sectors. Instructions for processing prisoners are given as part of all training. Prisoners are segregated by unit and rank. Interrogation reports accompany each prisoner to each successive headquarters.

Section II. BASIC TACTICAL PLANS

66. CAPTURED MATÉRIEL. a. Captured enemy arms and equipment are collected and may be given initial tests in forward areas. Troops are impressed with the necessity to watch for new weapons.

b. The Office of Captured Weapons reconditions and returns for use by Aggressor troops in the field many types of captured matériel.

67. OFFENSIVE. In general, the offensive is in the form of simultaneous attacks on a broad front with a concentration of artillery and tanks at the breakthrough points. The attack seeks to penetrate the enemy defenses in two or more sectors and converge on a limited objective. The enveloped enemy is then destroyed by simultaneous attacks from all directions. This scheme of maneuver is fundamental for units from platoon to army group levels. Coordination of combined arms under a single command is emphasized as a requisite toward achieving shock and surprise. Concentration of forces is accomplished with great secrecy. Elaborate precautions are taken to prepare in advance camouflaged dispersal areas for troops and matériel. Night activity is favored by Aggressor commanders.

68. MEETING ENGAGEMENT. While very similar to United States doctrine, certain features receive special emphasis. Speed of maneuver and rapid deployment of artillery are considered essential. Usually a strong advance guard is utilized. The Aggressor believes in an early attack in the meeting engagement. Sometimes Aggressor units will attack from march column, and thereby deprive the enemy of his freedom of action.

69. DEFENSE. a. The strength of Aggressor defense lies primarily in the determination of its troops. Ground is skillfully organized. Extensive use of mines is made both forward of the outpost line of resistance (OPLR) and within the battle positions. Mines may be found widely spaced or scattered at random in unmarked groups, and also in mine fields laid to a coded pattern. Dummy mine fields are employed with live fields to confuse the enemy. No consistency in marking of mine fields exists; in some instances, mines and mine fields are purposely left unmarked.

b. Defense is generally in considerable depth. Frequently, the reserve is limited to one-ninth of total infantry strength. Dummy positions are used extensively and often defended by small garrisons with equipment

to simulate intensive fire. A favorite maneuver is to permit the enemy to penetrate deeply and then trap his forces under observed fires. Machine guns are so emplaced as to bring flanking fire on attacking troops; in addition, extensive use is made of alternate machine gun (MG) positions. Antiaircraft (AA) artillery is prepared for defense against tanks.

c. Generally, forward dummy positions are sited to induce enemy attacks in direction which will be flanked by actual positions. Also, considerable use is made of reverse slopes with dummy positions on the forward slope. Within the OPLR, a false main line of resistance (MLR) is often constructed.

d. Surrenders en masse or by individuals are forbidden. When all hope of success has been abandoned, infiltration parties are started to the rear through enemy lines.

Section III. TACTICS OF GROUND ARMS

70. INFANTRY. a. Aggressor tactical employment of infantry is predicated on rapidity of maneuver of small groups, concentration of automatic fire, and shock action. There is a high proportion of automatic weapons and mortars.

b. The submachine gun (SMG) company is employed as a mobile reserve, for infiltration parties, and for protection of accompanying tanks. Considerable stress is laid on stealthy approach to an enemy position and opening a surprise concentrated fire at close range. Submachine gun elements are frequently employed in ambushes and general mopping up. In event of a counter-attack, SMG units attempt to circle to the flank and attack the enemy in rear.

c. SMG units may operate at company strength or be attached (farmed out) down to include the lowest echelon of the rifle platoons.

d. Heavy machine gun (HMG) sections are generally employed as a base of fire to support rifle elements. Flanking fire is emphasized. It is mandatory that for every machine gun position, three alternate positions are constructed and guns moved about frequently under cover *even if no enemy fire has yet been received on that particular position.*

e. Guns, which are dug in immediately if the attack is stalled, habitually cover the withdrawals.

f. Each rifle squad contains one LMG (US BAR). Its tactics follow the United States pattern, the gun being a base of fire for the remaining maneuver element of the squad.

g. Riflemen follow their artillery and mortar fires closely in the assault.

h. Centers of resistance are frequently bypassed. Small detachments are left to deal with them and the main elements proceed.

71. ARTILLERY. a. Artillery is employed on a large scale and in mass. Rockets and mortars, which are under the artillery arm, are employed

massed. Rockets are generally used only at critical times. Emphasis is placed on surprise and deception and alternate firing positions. Roving batteries are freely used.

b. Artillery is considered the main weapon of the defense. Surprise is considered of maximum importance in fire against personnel; prior adjustment direct on the target is permissible only in exceptional cases. Short bursts of sudden massed fire is desired.

c. A portion, usually one-fourth, of antitank guns must always be kept in mobile reserve.

72. ARMORED UNITS. Aggressor armored units are normally employed on a very narrow front and in great depth. When a tank attack is temporarily halted, hasty mine fields are immediately placed to protect the tanks.

73. CAVALRY. Aggressor cavalry is considered an independent striking force; however it is best used in coordination with infantry.

Section IV. SPECIAL OPERATIONS

74. GENERAL. a. Both large and small scale night operations are stressed. All are very carefully planned and coordinated.

b. Smoke is extensively employed both on a large scale over an extended length of time and on a small scale to cover the actions of an individual soldier.

Section V. FORTIFICATIONS

75. GENERAL. a. The Aggressor doctrine closely parallels the United States doctrine. However, camouflage of a defensive position is stressed as a principal requirement.

b. In hasty fortifications, mine fields are installed within 20 minutes of occupation of a position.

c. Deliberate fortifications are usually carried out before contact has been made with the enemy. The nerve center of every defensive zone is a strong point. Order of priority of construction seems to be (1) laying mines and antitank obstacles, (2) providing fire protection for the obstacles, and (3) shelters for men and equipment.

d. Trenches frequently follow an elevation contour. In case a strong point is small, trenches are almost continuous on its outer perimeter.

e. Fire discipline is stressed.

CHAPTER 5

FORTIFICATIONS AND DEFENSES

Section I. DOCTRINE OF FORTIFICATIONS

76. GENERAL. The Aggressor Army regards defenses and fortifications as a means of delaying and channelizing the enemy advance. Prepared defenses are usually mutually supporting and covered by fire from small arms and artillery weapons. Defenses and field fortifications are constructed as soon as the Aggressor advance is halted. These defenses and fortifications are continually developed when the area is occupied for a prolonged period of time. Economy of force is a fundamental principle in designing fortifications. Whenever possible, the Aggressor will use engineer equipment in preparing defenses and will often prepare areas well in advance of the time of occupancy of the positions. Normally, and if time permits, dummy and alternate positions are constructed immediately after the defenses are prepared. Camouflage of a defensive position is stressed as a principal requirement.

77. ORGANIZATION OF DEFENSES. a. Principle of depth. The Aggressors believe that a fortified line should consist of the following two characteristics:

(1) Small works, organized in depth acting as a buffer to slow down the enemy before the main defenses are reached.

(2) Strongpoints which are the nerve centers of the interconnected system of defensive positions that comprise every defensive zone. Aggressor troops are trained to continue the fight even when some positions of the defensive system have been overrun.

b. Zones of defense. The Aggressor achieves defense in depth by constructing three successive zones of defense.

(1) The forward zone contains trenches, mine fields, barbed wire entanglements, machine gun emplacements, observation posts and obstacles blocking the principal enemy approaches. Within the forward zone, a dummy forward edge for the main zone of resistance is sometimes built.

(2) The main zone consists of pillboxes, casemates, trenches, shelters, open and covered artillery emplacements, antitank obstacles covered by antitank guns, and isolated works at critical points along natural avenues of enemy approach. Intervals between strongpoints are planned to form pockets in which an enemy may be trapped under observed fire.

(3) The rear zone is similar to the main zone, but usually less developed. It is occupied by the reserves, and consequently, not as strong as the main zone. Frequently, the intervals between zones will contain alternate positions, antitank obstacles, and dummy positions.

c. Strength. The Aggressor doctrine provides for the greatest strength in the main zone of defense. Weak terrain is occupied in greater depth and made as strong as resources permit, and no terrain within the defensive zones is left without some form of defensive works.

d. Siting of defense works. Primary stress is on the availability of natural or artificial obstacles, fields of fire, and observation. Casemates and other occupied positions are so spaced as to provide interlocking fields of fire between defensive works, and yet dispersed so that no enemy artillery hit will affect more than one position. Trenches frequently follow an elevation contour.

e. Field works. Whenever possible, the Aggressor constructs defensive works in the nature of field fortifications well in advance of the time of manning the defenses. Such fieldworks include mine fields, obstacles, fire trenches for infantry weapons, and gun emplacements for artillery. Isolated strongpoints frequently have almost continuous trenches on their outer perimeter and gun emplacements near the center of the strongpoint, all of which provides for an all around defense. When time permits, communication trenches are constructed to link the positions together. Signal communications are established by the troops that occupy the position. The equipment employed to establish communications is organic to the troops manning the position.

Section II. CHARACTERISTICS OF FORTIFICATIONS

78. PRINCIPLES OF DESIGN. The basic principles in design of Aggressor fortifications are to provide for maximum effectiveness in delivery of fire and for cover and concealment. Fire effect has first priority in design. In order to provide ease of concealment and maximum cover from low angle fire, low silhouette works are most common. Emplacements, pillboxes, and casements are built no larger than necessary to permit crews to operate their guns.

79. CONSTRUCTION. Fieldworks are of earth reinforced with masonry, bricks, or timber. Emphasis is placed on the use of material readily available in the area. Permanent type fortifications are of concrete reinforced with steel.

80. OPEN EMPLACEMENTS. The Aggressor uses open emplacements for most of their weapons. The emplacement is usually an excavation and the material excavated is used to build up protective walls on sides

other than in the direction of fire. Artillery and mortars are frequently dug in and the excavated material used to build up the edges of the pit. The principles of low silhouette and camouflage are stressed in preparing open type emplacements.

81. PILLBOXES AND CASEMENTS. Permanent fortifications have not been encountered in the field, but are known to exist on the borders of the nation. They are of thick reinforced concrete with gun points for the firing of small weapons and embrasures, so constructed as to allow 90 degrees of traverse and elevation for heavy pieces. Thickness of concrete varies with the size of the pillboxes and is known to be 10 feet in the roof and walls of some fortress type works. Camouflage of permanent fortifications is accomplished by planting trees and shrubs to conceal the walls and covering the roofs with earth.

82. OBSTACLES. The tactical use by Aggressor of obstacles is usually limited to improvement of natural barriers, laying of mines, blocking approaches with antitank obstacles, barbed wire, and trenches. Order of priority of construction appears to be—

a. Laying of mines and constructing antitank obstacles. (In hasty fortifications, mine fields are installed within 20 minutes of occupation of a position.)

b. Providing fire protection for the obstacles.

c. Constructing shelters and close-in protection for men and equipment. The use of wires is stressed for close-in obstacles where both barbed wire fences and concertina wire are used. With the exception of wire and mines, Aggressor stresses use of locally available materials for construction of obstacles. Earth, stone, wood, and destroyed equipment are frequently used, and a combination of several materials is often used in the construction of antitank obstacles.

CHAPTER 6

LOGISTICS

Section I. GENERAL

83. GENERAL. a. The principles of supply and evacuation conform largely to United States practice. The system is characterized by careful long range planning. All operations are planned on the principle of the "firm base," that is, no campaign is undertaken until all supplies are up and in place. This is carried down to the finest detail. In planning, nothing is undertaken in which complete logistic support cannot be visualized. In fact, logistical considerations often outweigh tactical expediency.

b. Another peculiarity is the reorganization after battle which is termed "regrouping"; it is undertaken in great detail prior to the next offensive or other military undertaking and must be completed prior to initiating action.

Section II. SUPPLY AND EVACUATION

84. GENERAL. a. Supply and evacuation schedules for personnel and matériel are determined by a rigid system of priorities. The delivery of ammunition and fuel always takes precedence over all other classes of supplies.

b. Evacuation and reclamation of captured enemy matériel receives considerable stress in the Aggressor system. In fact, a special Office for Captured Weapons has its own agencies down to division level and handles recovery, transportation, storage, and reconditioning of captured weapons. It may also be charged with recovery of its own weapons. This is made necessary by the economic condition of the country; nothing is wasted.

c. The impetus of supply is from rear to front as in United States doctrine. Considerable use is made of the local transportation system in any area and of improvisation. Although the trend is toward full motorization, many second-line units still rely strongly upon horse-drawn transport. Local food resources and supplies are fully exploited.

d. Each division normally maintains a supply level of 5 days' rations, two refills of fuel, and one and one-half units of fire (U/F). In an average day's combat, it is expected that one-half of U/F of artillery ammunition will be expended. When necessary, troops carry four rations

on each individual. The U/F is approximately equal to the United States average per weapon. About 850 trucks are required to motorize a standard infantry division.

Section III. SYSTEM OF SUPPLY WITHIN AGGRESSOR

85. GENERAL. Supply within Aggressor is coordinated by the Armed Forces High Command working in conjunction with the Ministry for Armament and War Production. The Armed Forces Supply Office controls and supervises all supply activities throughout the Armed Forces; it operates through the Army Supply Office to supervise all supplies for the military establishment and the field forces. Each of the branches of the Aggressor Army which issues supplies and equipment is responsible for the design and development of the items under its control; it is also responsible for the storage and issuance of these items as needed by the field forces. These supply branches include all the technical services and the technical combat arms; they are: Quartermaster Corps, Ordnance, Engineers, Signal Corps, Chemical Warfare Service, Medical Corps, and Veterinary Service. In the matter of supplies and equipment, all of these branches are under the control and supervision of the Chief of Supplies and Equipment of the Home Command. Supply depots are located throughout Aggressor in the various corps areas, but are not under the control of the corps area commander. They come under the direct control of the chief of the branch concerned, being supervised and coordinated by the Chief of Supplies and Equipment.

86. TRANSPORTATION. a. All military transportation by rail or on inland waterways comes under the direction of the Chief of Transportation Corps at the Armed Forces High Command. He works through a chain of transportation headquarters which are usually subordinate to the Army but acts for the whole of the Armed Forces. The activities of the transportation headquarters cover any occupied territories as well as Aggressor. The Chief of Army Transportation works under the Chief of the Transportation Corps and coordinates all military needs for transportation.

b. Subordinate transportation headquarters are maintained throughout Aggressor, and act as regional liaison offices of the Armed Forces with the Aggressor railway system and the authorities controlling the transportation on inland waterways. These transportation headquarters are the basic units through which all military agencies must deal if they require rail or water transportation for units, freight, or casualties. The transportation headquarters make the transportation available and issue orders as to how and when they are to be used.

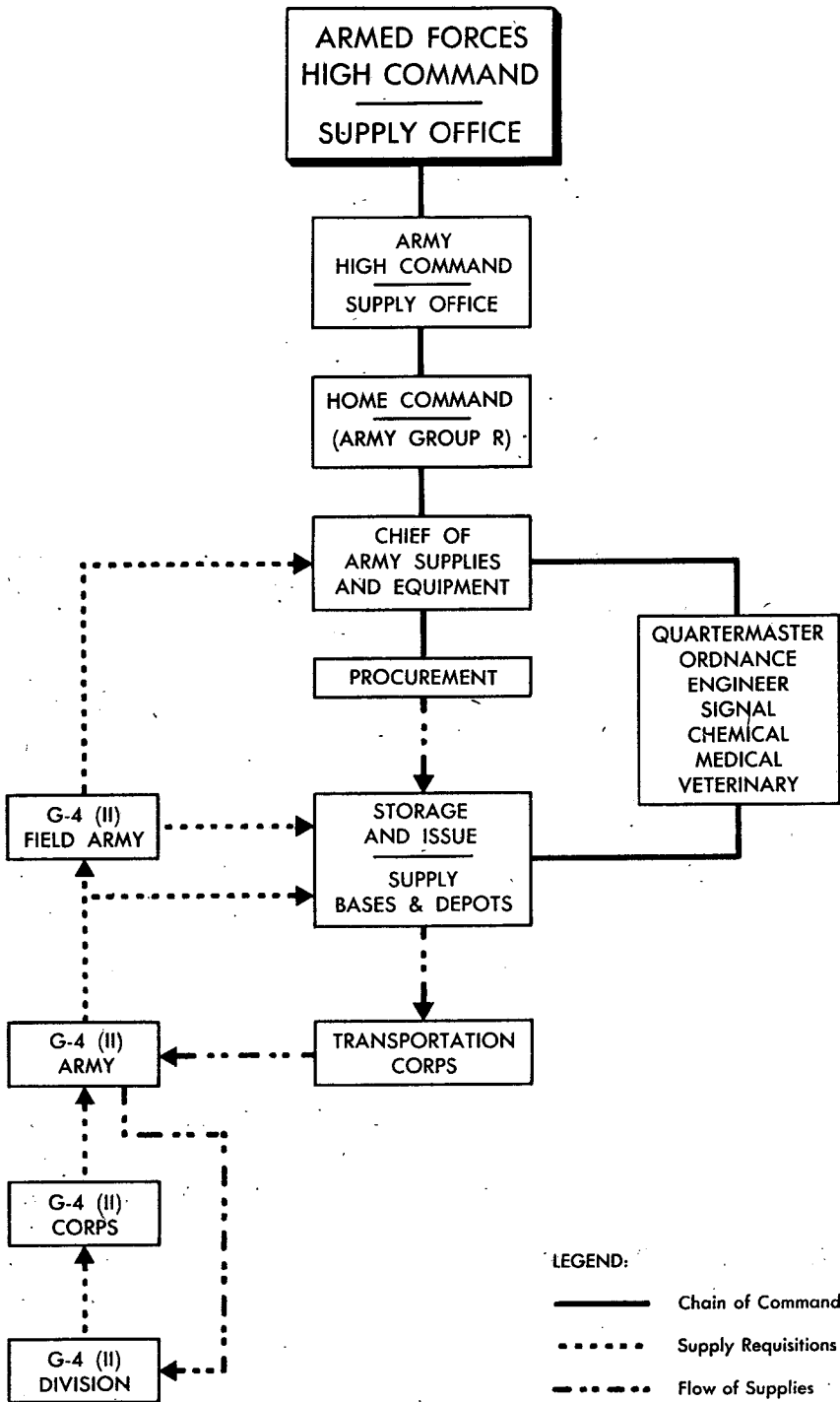

Figure 52. Flow of supplies.

c. Subordinate to the transportation headquarters are railway station headquarters and officers stationed at inland harbors. These headquarters and officers are stationed there for the maintenance of order and act as liaison officers with the local railway and harbor officials. Air transportation is also under the Armed Forces Chief of Transportation Corps, but only Air Force officers are detailed at the various civilian air ports to act as liaison or control officers.

Section IV. SYSTEM OF SUPPLY OF THE FIELD ARMY

87. GENERAL. The supply system of the Field Army is simple and flexible. Its main objective during combat is to replace all supplies used during one day of combat by the beginning of the next day. Rules and regulations are not mandatory; much discretion therefore remains with the supply officers who are encouraged to move supplies as far forward as possible without reloading, to salvage all usable material, and to limit expenditure of supplies as far as possible.

88. STAFF CONTROL. a. Supply directives. The commanders of Field Army units conduct supply within their commands in accordance with directives laid down by the Army High Command. For this purpose their general staff sections are provided with staff officers (Section II), analogous to our G-4's, who are responsible for all matters of transport and supply.

b. Staff officers and duties. The staff officers concerned with supply in the Field Army and their duties are as follows:

(1) At Field Army headquarters, the Chief of Field Army Supply and Administration (Section II) is directly responsible to the Chief of Staff of the Field Army and constantly is kept informed of the supply situation of the various armies. One of his main functions is forwarding the requirements of the armies to the Chief of Army Supplies and Equipment. He regulates the evacuation of prisoners and wounded, and the use of communications in the theater of operations. Large stocks of materials, including captured materials and mobile supply trains, are under his control. Important repair centers are also maintained under his control.

(2) At army group headquarters, the Army Group II intervenes only when a critical situation requires action, since army groups are not in the normal chain of supply. Normally his most important function is the supervision of security units which safeguard supplies in the communications zones. Units attached to an army group are supplied through the army in whose area they are located.

(3) At army headquarters, the Army II administers the collation and forwarding of requisitions, the receipt of supplies from the Zone of the Interior depots, the distribution of supplies to lower echelons, and the maintenance of important supply dumps and repair centers.

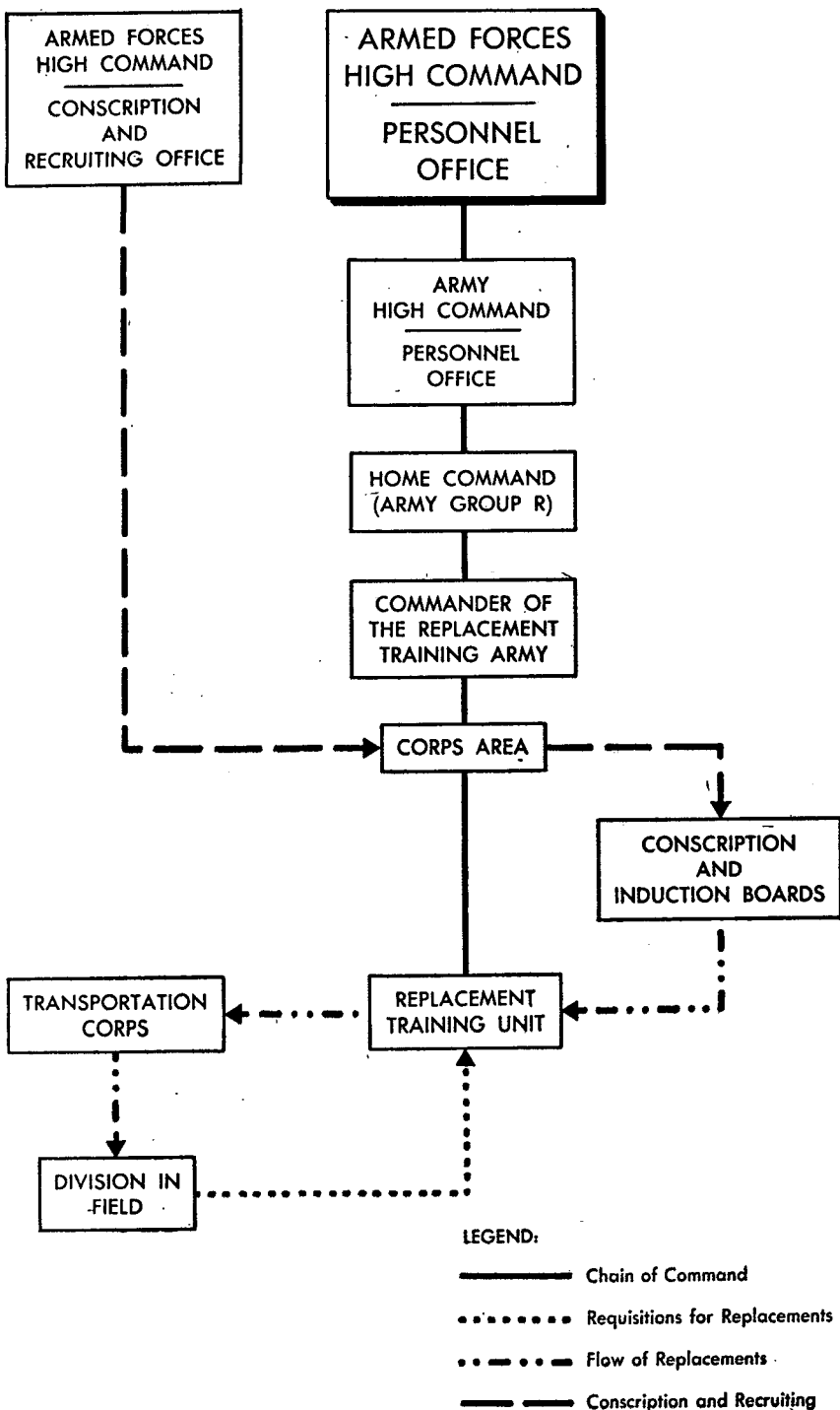

Figure 53. Flow of replacements.



(4) At corps headquarters, the Corps II handles the supply of organic corps troops, and supervises the distribution of supplies from corps dumps to lower echelons. Requisitions from the divisions go through the Corps II despite the fact that most supplies go direct from army dumps to division dumps.

(5) At division headquarters, the Division II makes his requisition to the Corps II on the basis of requisitions and reports from the troop units. He controls the division services of supply and provides a systematic supply of reserves of all kinds for the troops. Like the Army II, he is in the normal chain of supply.

89. REQUISITIONING AND PROCUREMENT. The complete operation of the Aggressor supply system is shown graphically in figure 52. This chart shows the procurement, storage, and issue of supplies in Aggressor, and their transportation to the armies in the field. It also shows the flow of requisitions from divisions back to the Home Command.

a. Requisitioning. (1) The normal channel of requisitioning is from troop units through channels to division headquarters, then to corps and army.

(2) An army generally sends requisitions for engineer, signal, chemical warfare, ordnance, and quartermaster automotive supplies to the Field Army, while requisitions for medical, veterinary, and other quartermaster supplies go direct to home depots assigned to that army. Some special weapons and chemical warfare requisitions, however, may go direct to the Chief of Army Supplies and Equipment if deemed necessary, and emergency quartermaster food or clothing requisitions may be sent to the Field Army.

(3) Requisitions arriving at the Field Army usually are forwarded to the Chief of Supplies and Equipment, who passes them down to a designated home depot. In some cases, however, the Field Army may send requisitions direct to a home depot without routing them through the Chief of Army Supplies and Equipment.

(4) A requisition may be filled at any level by the echelon which has the necessary supplies available in its storage centers.

b. Procurement. Requisitioning is supplemented by two methods of field procurement: living off the land and the use of captured matériel.

(1) Living off the land may be accomplished by local purchase or by outright confiscation of local supplies. Such procedure seldom is sufficient to supply all the requirements of units. In some areas, nevertheless, it has considerably lessened the Aggressor supply problem, particularly where great stores of goods are available.

(2) The employment of captured matériel has always been a favored practice in the Aggressor Army, and is in accordance with their supply doctrines.

Section V. TROOP MOVEMENTS

90. TRANSPORTATION. Troops are moved by air, sea, rail, or motor according to logistical or tactical priority. It is the duty of the Armed Forces Chief of Transportation Corps to coordinate all personnel movements of the three branches of the Armed Forces with the movement of supplies and equipment to the forces in the field. The Chief Army Transportation Officer acts as liaison officer between the Army High Command and the Chief of the Transportation Corps, and coordinates all army transportation from the Zone of the Interior to the Field Army. Within the theater of operations, however, the army usually moves its troops with organic transportation; large-scale rail troop movements in the field, however, must be coordinated with other transportation movements under the direction of a transportation corps headquarters.

91. REPLACEMENTS FOR THE FIELD ARMY. Figure 53 shows graphically the flow of replacements from the conscription and induction stage to their arrival at a division in the field. The replacement system has already been described in detail in section V of chapter 1.

CHAPTER 7WEAPONS

Section I. GENERAL

92. GENERAL. Aggressor weapons conform closely to United States design and capabilities. Actually, a great many American-made weapons, vehicles, and other items of equipment are in the hands of Aggressor forces, as a result of clandestine deals and barter with other governments that had obtained this equipment through lend lease, surplus sales, and other means. It is not unusual to find in use other foreign-made weapons obtained through the same methods. Ordnance manufacture has not as yet been put on a mass production basis.

Section II. SMALL ARMS

93. GENERAL. The type rifle most generally found is a bolt action model of the Mauser type similar to the United States Model 1903. However, a semi-automatic weapon similar to our M-1 used in the late German Army is being developed and is gradually replacing the bolt action rifle in the more elite units. The light machine gun is actually a BAR type shoulder automatic weapon and is supplemented by the Bren and Schmeisser; the heavy machine gun is a water-cooled, belt-fed model similar generally in design to the United States HMG. The submachine gun is the United States Thompson .45, and similar guns of domestic manufacture.

Section III. MORTARS

94. GENERAL. a. In general, mortars parallel American types in caliber, design, and capabilities. However, a wider range of calibers is employed. The 50-mm corresponds favorably to our 60-mm and the 81-mm is practically identical to the United States model, even to the extent of interchangeability of ammunition.

b. In the heavier mortars, the most commonly used is a 120-mm which is slightly heavier than a United States 4.2-inch mortar. However, it outranges the latter by about 2,000 yards. Several heavier field mortars are known to exist.

Section IV. ARTILLERY

95. GENERAL. In the field of artillery, the majority of weapons, including antiaircraft and antitank, are of conventional design and caliber and closely resemble the American counterpart.

Section V. MAXIMUM EFFECTIVE RANGES

96. ARTILLERY. a. Regular artillery.

<i>Type of weapon</i>	<i>Maximum effective range (yards)</i>
75-mm gun	13,850
75-mm gun, recoilless (airborne division)	8,900
75-mm howitzer	9,610
80-mm gun (SP)	14,000
120-mm gun (SP)	18,000
120-mm howitzer	14,000
150-mm gun/howitzer	20,000
150-mm gun (SP)	25,000

b. Mortars.

<i>Type of weapon</i>	<i>Maximum effective range (yards)</i>
50-mm mortar	570
81-mm mortar (mechanized infantry regiment) ...	2,625
81-mm mortar (standard infantry battalion)	1,600
105-mm smoke mortar	3,300
120-mm mortar	6,600

c. Antitank artillery.

<i>Type of weapon</i>	<i>Maximum effective range (yards)</i>
20-mm AT gun	5,230
57-mm AT gun	9,840
75-mm AT gun	13,730
105-mm AT gun	18,000

d. Antiaircraft artillery.

<i>Type of weapon</i>	<i>Maximum effective range (yards)</i>
20-mm AA gun:	
Effective ceiling	1,200
Maximum horizontal range	5,230
40-mm AA gun:	
Effective ceiling	2,000
Maximum horizontal range	10,850

e. Rockets.

<i>Type of weapon</i>	<i>Maximum effective range (yards)</i>
150-mm rocket launcher	7,330

f. TD guns.

<i>Type of weapon</i>	<i>Maximum effective range (yards)</i>
57-mm TDs	9,840
75-mm TDs	13,730

97. TANKS.

<i>Type of weapon</i>	<i>Maximum effective range (yards)</i>
Medium tank (90-mm guns) (tank on incline)	13,540
Medium tank w/105-mm howitzer	12,210
Light tank (37-mm gun)	4,300
Light tank w/47-mm gun	6,000
Flame thrower tank	100

98. RECONNAISSANCE.

<i>Type of weapon</i>	<i>Maximum effective range (yards)</i>
Armored cars (20-mm)	5,230
Armored motorcycles (HMG)	Up to 1,200

99. INFANTRY.

<i>Type of weapon</i>	<i>Maximum effective range (yards)</i>
Submachine gun (cal. .45)	Up to 150
Light machine gun (cal. .30)	Up to 800
Heavy machine gun (cal. .50)	Up to 1,200
Rifle (cal. .30)	Up to 600
Pistol (cal. .45)	Up to 50
Machine pistol, <i>Bren</i> and <i>Schmeisser</i> (cal. .38)	Up to 150

CHAPTER 8EQUIPMENT

Section I. GENERAL

100. GENERAL. As with weapons, much Aggressor equipment is identical or very similar to United States equipment. It was captured, obtained through other countries, salvaged in Europe, or copied outright from United States models. As further information is obtained, it will be disseminated to all commands concerned.

Section II. ARMORED VEHICLES

101. GENERAL. The Aggressor armored vehicles conform closely to the United States counterpart. Light, medium, and heavy tanks are nearly identical to ours in weight, characteristics, and appearance.

Section III. VEHICLES

102. GENERAL. Due to the prevalence of American-made vehicles and the close imitation of those nationally produced, a discussion of Aggressor vehicles is not needed.

CHAPTER 9AGGRESSOR AIR FORCE

Section I. GENERAL

103. **GENERAL. a.** The Aggressor tactical air force is believed to be formed along the lines of a modern, efficient air force.

b. A large, well-equipped air transport command has been formed from surplus United States cargo aircraft. It has been developed for rapid movement of air-transportable ground formations.

Section II. ORGANIZATION

104. **GENERAL. a.** The organization of the air force is not, at this time, clear. When more information on the Aggressor Air Force organization is available, it will be disseminated to all concerned.

b. It is believed that no independent strategic air force now exists.

Section III. DOCTRINE AND TACTICS

105. **GENERAL.** In general, Aggressor formations and tactics conform to United States practice.

Section IV. AIRCRAFT

106. **GENERAL. a.** Aggressor aircraft closely follow conventional design. Some jet propelled planes have been developed, but they are not yet in sufficient number to be important.

b. Some formations are equipped with a plane which closely resembles the United States A-26 in appearance and characteristics. Bombers most commonly encountered resemble the United States B-25 and fighters, generally of the P-47 and P-51 types. A type of aircraft resembling our P-38 is also being developed, and some operational squadrons of this type are known to exist. This aircraft is heavily armed and suitable for missions against ground troops and armor.



APPENDIX I.

CONVENTIONAL SIGNS AND SYMBOLS

Note. These CONVENTIONAL SIGNS AND SYMBOLS are to be used by Aggressor troops, particularly in maps and documents prepared for capture by United States troops. They do *not* apply to intelligence operations, situation maps, or reports of United States Army troops.

Section I. INTRODUCTION

i. INTRODUCTION. a. Conventional signs and marginal data found on Aggressor maps are very similar to those on our own maps. In fact, many of the maps used by the Aggressor were captured from our stocks during the California campaign.

b. Coordinates however, cannot be read direct from their maps without first checking the maps.

c. The Aggressor grid system may be overprinted. Also, a system may be used to disguise the reading of coordinates, i. e., thrustline and map coordinate codes.

d. Military symbols are a consolidation of the symbols contributed by the various groups of military personnel which formed Aggressor—Spanish, Italian, French, German, and miscellaneous soldiers of fortune. Besides the standard agreed list of symbols, many a hard-pressed Aggressor draftsman has been known to go back to his original army's symbols or to invent the needed symbols on the spot. In such cases, however, a key is added to the legend as a rule.

e. Aggressor friendly information is normally shown in *black*. Information of the enemy is shown by them in *red*.

Section II. MILITARY SYMBOLS

2. TO INDICATE PURPOSE OR CHARACTER OF ACTIVITY.

Headquarters (formation)



Headquarters of unit



Command post



Headquarters of command



Supreme command



General officer commanding



3. TO INDICATE ARM OR SERVICE
OR ACTIVITY OF ARM OR SERVICE.

Infantry



Armored infantry



Airborne infantry



Parachute infantry



Ski infantry



Artillery



Artillery survey



Artillery observation unit



Artillery air observation unit



Sound ranging section



Armored



Cavalry



Guided missile

















Rocket



Engineer



Antitank	
Antiaircraft	
Motor transport	
Signal	
Quartermaster	
Chemical warfare	
Ordnance	
Medical	
Veterinary	
Railway	
Police	
Labor	
Postal	
Forward line of communications (i.e., in front of railhead)	
Line of communications	

TO INDICATE SIZE OF UNITS.

Army



Army corps



Division



Brigade



Regiment or group



Battalion or squadron



Company, troop, battery, or flight



Platoon



Section (or unit next below platoon)



5. BOUNDARIES.

Army 

Army corps 

Division 

Regiment 

Battalion, or equivalent units 

Company, or equivalent units 

Limit of reconnaissance 

Objective 















Line of outguards 

Outpost line of resistance 

Main line of resistance 

Fire sector (Principal direction of fire is indicated by direction of conventional sign inserted to indicate weapon.) 

6. WEAPONS

Rifle	
Automatic rifle	
Heavy machine gun	
Machine gun	
20-mm AA machine gun	
50-mm light mortar	
81-mm medium mortar	
Heavy mortar (100-mm) (120-mm)	 10.
Flame thrower	
Infantry cannon (75-mm) (105-mm)	 7.5
Bazooka	
20-mm AT gun	
57-mm AT gun	
75-mm AT gun	
75-mm gun	



75-mm mountain howitzer



40-mm AA gun



90-mm AT-AA gun



120-mm gun



120-mm gun/howitzer



120-mm howitzer



150-mm gun



150-mm gun/howitzer



150-mm howitzer



150-mm AT-AA gun



210-mm gun



210-mm gun/howitzer

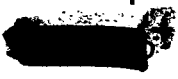

~~RESTRICTED~~

240-mm howitzer

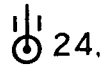

150-mm rocket (conventional) launcher

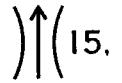

210-mm rocket (conventional) launcher

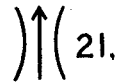

50-cm guided missile launcher

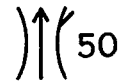

100-cm guided missile launcher

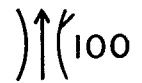

Battery or its fire position (75-mm)



Fire position, selected or alternate (120-mm) or suspected enemy battery when in red



Dummy gun



Dummy battery



~~RESTRICTED~~

Light tank



Medium tank



Heavy tank



Tracked vehicle



Flame thrower tank



Amphibious or seagoing tank



Motorized gun (80-mm) (120-mm) (150-mm)



Command tank



Armored personnel carrier



Heavy armored car



Light armored car













Truck 4 x 4, 1/4-ton



Truck

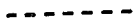

7. COMMUNICATIONS.

Telephone apparatus	
Telephone central (number indicates number of lines)	 (6)
Telephone test station or point	
Telegraph station	
Telegraph central	
Radio station	
Light signaling post	
Rocket or flare signaling post	
Field telephone line (Number indicates number of circuits.) (Communication lines usually in yellow.)	 (4)
Field telegraph line	
Cable, telephone or telegraph	
Open cable —Cavo aperto (c.a.)	
Underground cable—Cavo sotterano (c.s.)	
Underwater cable —Cavo subaqueo (c.sa.)	
Field observation post*	

* To indicate the command to which an observation post belongs, there is placed at the side of the sign an indication identifying the command itself. The point is to mark the exact position of the observation post.



Observation post in a dugout or fortified position



Artillery observation post



Liaison plane strip



8. CHARACTERISTICS OF TERRAIN AND ORGANIZATION OF FIRE.

Ordinary trenches



Fortified trenches



Trenchwork under construction

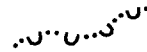

Line of trench elements

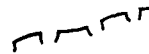

Wall adapted to defense



Portion of building reinforced for defense
(On sketches and overlays.)



Machine gun emplacement



Machine gun emplacement (underground)



Emplacement for AT guns



Emplacement for artillery



Underground shelter

(The number indicates the number of men to be accommodated.)



Concertina wire

(Number in indicates number of rows, number in () indicates depth in meters.

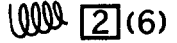

Barbed wire



Cheval-de-frise



Demolition prepared

(Number indicates kilograms explosive.)

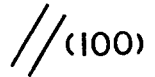

Demolition blown



Tree-felled entanglement



Antitank obstacle

Antitank ditch



Antitank mines





Antipersonnel mines

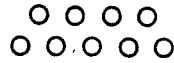

Bounding antipersonnel mines

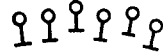

Trip-wired mines



Area gassed (yellow)



Area flooded (blue)



9. MEDICAL.

Forward collection point (Bn)



First aid station (Regt)



Ambulance station



Collecting station for walking wounded



Collecting station (Div)



Evacuation hospital



Base hospital



Veterinary hospital





10. SUPPLY.

General dump



Munitions dump



Materials dump



Munitions and materials dump



Motor transport fuel and lubricants dump



Aviation fuel and lubricants dump



Food dump



11. ORDNANCE.

Forward repair shop (Div)



Central maintenance shop (Corps, Army)



Base maintenance shop





12. GROUND SIGNS USED BY TROOPS FOR COMMUNICATION WITH AIRCRAFT.

Position for dropping messages



Do not understand



Understood (can also mean "yes")



Enemy preparing attack



Enemy is attacking



Enemy has penetrated our position



Enemy has penetrated on our left



Enemy has penetrated on our right



Front line



No



We are surrounded



Reinforcement necessary



Center of enemy resistance



Enemy batteries



Enemy attack repulsed



We are holding the line



We require ammunition



Food supplies required



We advance (are ready to attack)



13. MOTORIZATION OF UNITS.

Fully motorized



Partly motorized



Fully tracked



Half tracked



No motorization



Horse drawn



14. COMBINATION OF SYMBOLS AND DESIGNATION OF IDENTITY.

- a. Aggressor symbols may be compounded to show size and arm or branch of units.
- b. Numbers are used to show numerical identity of unit:
 Army — SEGUNDO
 Corps — 11
 Division — 2
 Brigade — 11
 Regiment — 2
 Battalion — 11
 Company — 2
- c. Identifying numbers are written to the right of a symbol.
- d. The number of a subordinate unit is written to the left of the symbol and the parent unit is identified by a number to the right. Numbers are used with the size symbol alone, with a combination of size and branch or service symbol, or with weapons symbols. Where symbols are not complete in themselves, complete identity can usually be determined by location of symbols on overlays, maps, and similar items:

Second Army



Fourth Infantry Division

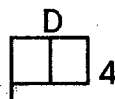

Command Post Fourth Infantry Division

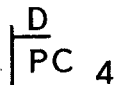
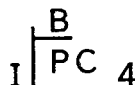
Command Post First Brigade Fourth
Infantry Division

Hq Thirtieth Armored Division

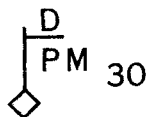

Command Post Artillery Brigade
Fourth Inf. Div.

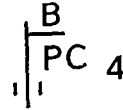

35 Infantry Regiment 54 Infantry
Division (Mtz)

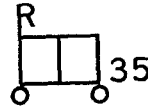

Rocket Battalion 3 Fusilier Division

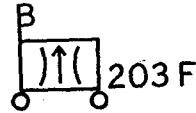

Antiaircraft Battalion 14 Infantry Division

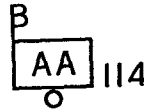

Mortar Regiment 32 Armored Division

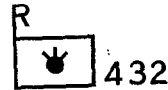

98 Tank Regiment 50 Armored Division

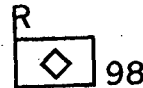

Submachine Gun Company 3 (Armored
Infantry) Battalion 100 Tank Regiment

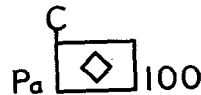

1 Company, 2 Battalion, 100 Tank Regiment

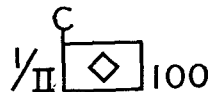

438 Artillery Regiment, 111 Artillery
Brigade (25 Artillery Division)

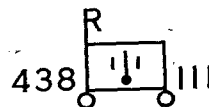

R



201 Artillery Regiment (3 Mechanized Division)

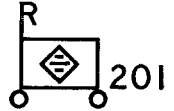

16 Cavalry Regiment (10 Cavalry Division)

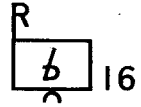

Aid Station, 14 Infantry Regiment



Repair Shop 23 Infantry Division



10 Fusilier Division

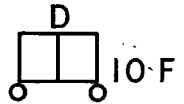

Reconnaissance Regiment, 2 Mechanized Division

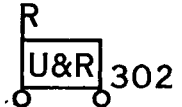

Service Company, 2 Mechanized Division

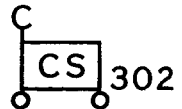

APPENDIX II.

GLOSSARY OF COMMON AGGRESSOR
MILITARY TERMS

Section I. ENGLISH—SPANISH, ITALIAN, FRENCH, GERMAN

I. WORDS.

English	Spanish	Italian	French	German
abatis	tala	abbattuta	abatis	Astverhau; Baumverhau
action	accion	azione	action	Aktion
adjacent	adyacente	adiacente	adjacent	angrenzend
adjutant	ayudante	aiutante	adjoint	Adjutant
advance	avance	avanzata	avancer	Vormarsch
aerial	aerea	aereo	aerien
aim	punteria	punt	pointer	Ziel
aiming	punteria	puntamento	pointage	zielen
air	aire	aria	air; aerienne	Luft
airplane	aeroplano	aeroplano	aeroplano	Flugzeug
alert	alerta	all'erta	alerte; alerter	Bereitschaft; wachsam
ambulance	ambulancia	ambulanza	sanitaire	Ambulanz
ammunition	municion	munizioni	munitions	Munition
antiaircraft	antiaereo	antiaereo	antiaerien	Flugabwehr
antitank	antitanque	anticarro	antichars	Panzerabwehr
area	area	area	Gebiet
arm	arma	arme	armes	Waffe
armed forces	forze armate	Wehrmacht
armor	coraza	corazza	blindage	Panzer
army	ejercito	esercito	armee	Armee; Heer
artillery	artilleria	artiglieria	artillerie	Artillerie
assault	asalto	assalto	assaut	Angriff
assembly	asamblea	adunata	rassemblement	Sammeln
attach	incorporar	zuteilen
attack	ataque	attacco	attaque	Angriff
aviation	aviacion	aviazione	aviation	Flugwesen
aviator	aviador	aviatore	aviateur	Flieger
balloon	globo	pallone	ballon	Ballon
barrage	barrera	sbarramento	barrage	Sperrfeuer
barrel	tubo	canna	canon	Lauf
barrier	barrera	barriera	barriere	Sperre
battalion	battallon	battaglione	bataillon	Bataillon
battery	bateria	batteria	batterie	Batterie
battle	batalla	battaglia	bataille	Kampf
beachhead	cabeza de playa	testa di sbarco	de debarquement	Brückenkopf an feindlicher Küste
besiege	sitiar	assediare	assiéger	belagern
blast	rebufo	scoppio	detonation	Sprengung
blockade	bloqueo	blocco	blocus	Blockade
bomb	bomba	bomba	bombe	Bombe
boundary	limite	limite	limite	Grenze
breechblock	cierre	otturatore	bloc de culasse	Verschlusblock
brigade	brigada	brigata	brigade	Brigade

English	Spanish	Italian	French	German
brigadier general bullet	general de brigada bala	Generale di Brigata pallottola	general de brigade balle	Generalmajor Kugel
cable caisson caliber camera	cabo rastra calibre camara fotografica	cavo cassone calibro macchina fotografica	cable caisson calibre appareil photographique	Kabel Munitionswagen Kaliber Kamera
camp campaign cannon cannoneer capitulate captain capture car carbine carrier	campamento campana canon artillero capitular capitan capturar vehiculo carabina vehiculo de transporte	campo campagna cannone capitolare capitano cattura carro carabina vettore	campement campagne canon servant capituler capitaine capture auto carabine porteur	Lager Feldzug Kanone Kanonier kapitulieren Hauptmann Gefangennahme Wagen Karabiner Trager
cartridge casemate casualties cavalry cemetery charge chemical warfare	cartucho casamata bajas caballeria cementerio carga guerra quimica	cartuccia casamatta perdite cavalleria cimitero carica guerra chimica	cartouche casemate pertes cavalerie cimetiere charge guerre chimique	Patrone Kasematte Kriegsverluste Kavallerie Friedhof Ladung Gaskrieg
chevron chief circle city civil affairs civilian coaxial collecting point	cheuron primero circulo ciudad asuntos civil civil coaxial punto de agrupamiento	gallone capo circolo citta borghese posto raccolta feriti	chevron chef cercle ville civil coaxial poste de rassemblement des eclopes	Uniformwinkler Chef; Haupt Kreis Stadt Zivilverwaltung Zivilist koaxial Sammelpunkt
colonel column combat command commander command post commission commit communication	coronel columna combat mando comandante puesto de mando comision empenar comunicacion	colonnello colonna combattimento comando comandante commissione comunica- zione	colonel colonne combat commandement commandant poste de commandement brevet communication	Oberst Kolonne Kampf Kommando Kommandant Kommandostelle Kommission begehen Nachricht
company compass conceal	compania brujula oculto	compagnia bussola mascherare	compagnie compas cacher	Kompanie Kompass gegen Sicht decken
concentration	concentracion	concentra- zione	concentration	Aufmarsch
concertina construct construction contour control conventional signs cook corporal corps	concertina constuir construccion contorno control signo convencional cocinero cabo cuerpo	concertina costruire costruzione contorno controllo segno con- venzionale cuoco caporale corpo	reseau brun construire construction contour diriger cuisinier caporal corps	Drahtwalze bauen Konstruktion Kontur Kontrolle Kartenzeichen Koch Obergefreiter Korps

English	Spanish	Italian	French	German
counterattack	contraataque	contrattacco	contre-attaque	Gegenangriff
countersign	contrasigna	contrassegno	contre-mot	Parole
country	pais	paese	contree	Land
court-martial	consejo de guerra	corte marziale	cour martiale	Kriegsgericht
cover	proteccion	riparo	couvert	Deckung
crew	tripulacion	serventi	equipe	Bemannung
dam	diga di sbarramento	atardeau	Damm
danger	perigo	pericolo	danger	Gefahr
darkness	obscuridad	oscurita	obscurite	Dunkelheit
date	fecha	data	date	Datum
day	dia	giorno	jour	Tag
daylight	luz deldia	luce del giorno	Tageslicht
dead	muerto	morto	mort	Tot
deceive	enganar	ingannare	betrogen
decoration	condecoracion	decorazione	decoration	Auszeichnung
defeat	derrota	sconfitta	defaite	Niederlage
to defeat	derrotar	sconfiggere	defaire	schlagen; uberwinden
defense	defensa	difesa	defense	Abwehr
delay	retardar	ritardo	retarder	Verzogerung
delaying action	accion dilatoria; resistencia retardante	action retardrice	hinhaltendes Gefecht
demolition	demolicion	demolizione	demolition	Zerstörung
density	densidad	densita	densite	Dichtigkeit
department	departamento; ministerio	dipartimento	departement	Verwaltungs- bereich
depth	profundidad	profondita	profondeur	Tiefe
deserter	desertor	disertore	deserteur	Überläufer
detachment	destacamento	distaccamento	detachement	Abteilung
detail	fraccion; grupo	drappello	detachment	Abteilung
detonate	estallar; hacer explosion	detonare	detoner	detonieren
detonator	detonador	detonante	detonateur	Zundkapsel
develop	desplegar	sviluppare	developper	entwickeln
dig	cavar	scavare	creuser	graben
to dig in	afosarse	trincerarsi	creuser des tranchees	eingraben
direction	direccion	direzione	direction	Richtung
disabled	invalido; inutilizado	inabilitato	hors de combat	untauglich
disaster	desastre	disastro	desastre	Unglück
discipline	disciplina	disciplina	discipline	Disziplin
distance	distanca	distanza	distance	Entfernung
district	region militar; zona militar	distretto	region	Bezirk
ditch	zanja; foso	fosso	fosse	Graben
division	division	divisione	division	Division
document	documento	documento	document	Urkunde
dressing station	puesto de socorro	posto di medicazione	poste de secours	Verbandplatz
dump	deposito provisional	deposito	provisoire	Lager
duty	servicio	servizio	devoir	Dienst
earthwork	atrincheramiento	opera in terra	travaux de terrassement	Erdwerke
east	este	est	est	Ost

English	Spanish	Italian	French	German
echelon	escalon	scaglione	echelon	Staffel
effective	efectivo	effettivo	efficace	wirksam
eliminate	eliminar	eliminare	ausscheiden
emplace	emplazar	postare	mettre en batterie	in Stellung bringen
emplacement	emplazamiento	postazione	emplacement	Stellung
encircle	rodear	accerchiare	encercler	umzingeln
encircling	fuerza	forze	elements de	Umfassungs-
force	envolvante	accerchianti	poursuite strategique	gruppe
encounter	encontrar	scontro	rencontre	Treffen
enemy	enemigo	nemico	ennemi	Feind
engagement	encuentro	scontro	engagement	Gefecht
engineer	ingeniero	geniere	genie	Pionier
entanglement	obstaculo de alambres	reticolato	enchevetrement	Verhau
envelop	envolver	avviluppare	envelopper	umfassen
envelopment	envolvimiento	avviluppa- mento	enveloppement	Umfassung
envelopment, double	envolvimiento doble	avvolgimento di ambedue le ali	debordement par les deux flancs	doppelte Umfassung
equipment	equipo	equipaggia- mento	equipement	Gerat
evacuate	evacuar	evacuare	evacuer	abschieben
excavate	excavar	scavare	excaver	ausgraben
feint	amago	finta	feinte	Ablenkungsan- griff
fence	cerca	siepe	barriere	Zaun
fence; wire	cerca de alambre	reticolato	Drahtzaun
field	campo	campo	champ	Feld
fighter	combatiente	combattente	batailleur avion de chasse (Avn)	Kampfer
file	hilera	fila	file	Reihe
fire	fuego	tiro	feu	Feuer
first lieutenant	teniente; primer teniente	tenente	lieutenant	Oberleutnant
first sergeant	sargento primero	sargent-chef	Feldwebel
flag	bandera	bandiera	drapeau	Fahne
flame thrower	lanzallamas	lanciafiamme	lance-flammes	Flammenwerfer
flank	flanco	fianco	flanc	Flanke
flank (v.)	flanquear	fianco	flanquer	Flanken
flare	luz de senal; cohete de iluminacion	razzo	eclairante	Lichtsignal
flash	fogonazo (gun)	vampa	lueur	Mundungsfeuer
flight	vuelo	volo	vol	Flug
fluid	fluido	fluido	fluide	Flussigkeit
fly	volar	volare	voler	fliegen
force	fuerza	forza	troupe; detachment	verband
ford	vado; paso de rio	guado	gue	Furt
formation	formacion	formazione	formation	Gliederung
fortification	fortificacion	fortifica- zione	fortification	Festung
fortify	fortificar	fortificare	fortifier	befestigen
fox hole	pozo de tirador	buca da tiratore	trou de tirailleur	Fuchsloch

English	Spanish	Italian	French	German
friendly	amigable	amichevole	amies	freundlich
front	frente	fronte	front	Front
front line	primera linea; linea del frente	linea de fronte	premiere ligne	Kampffront
fuel	combustible	combustibile	combustible	Kraftstoff
fuze	espoleta	spoletta	fusee	Zunder
gas	gas	gas	gaz	Gas; Kampfstoff
gasoline	gasolina	benzina	essence	Benzin
general	general	generale	general	General
general staff	estado mayor general	stato maggiore generale	etat-major	Generalstab
grenade	granada	granata	grenade	Granate
grenadier	granatiere	Grenadier
ground	tierra	terreno	terre	Grund
group	grupo	gruppo	groupe	Gruppe
gun	canon	cannone	canon	Geschutz
gun crew	dotacion del canon	servants de la piece	Geschutzbe- dienung
gunner	artillero; apuntador; ametrallador	artiglieri	pointeur	Schutze
halt	alto	fermata	halte	Halt
hand grenade	granada de mano	granata di mano	grenade a main	Handgranate
harass	hostigar	molestare	harceler	storen
hasty	pronto	pronto; presto; rapido	rapide	eilig
hasty	posicion	rapide d'une
position	improvisada	position
headquarters	cuartel general	quartiere generale	quartier general	Hauptquartier
helmet	casco	elmetto	casque	Helm
helper	asistente	aiutatore	aide	Helfer
high	alto	alto	haut	hoch
highway	camino real	strada	de grande route	Hauptstrasse
hill	colina	collina	colline; coteau	Hugel
hit	pegar	colpo	atteindre	Treffer
hollow	hueco	conca	creux	hohl
horse	caballo	cavallo	cheval	Pferd
hospital	hospital	ospedale	hopital	Lazarett
hostile	hostil	ostile	hostile	feindlich
hour	hora	ora	heure	Stunde
howitzer	obus	obice	obusier	Haubitze
ice	hielo	ghiaccio	glace	Eis
identification	identifi- cacion	identifi- cazione	identifi- cation	Erkennung
ignite	encender	accendere	enflammer	zunden
igniter	cebo	cannelo fulminante	charge d' inflammation	Zundvorrichtung
impact	impacto	cozzo	impact	Aufschlag
incendiary	incendiario	incendiario	incendiaire	Brandstifter
independent	independiente	indipendente	selbstandig
infantry	infanteria	fanteria	infanterie	Infanterie
intelligence	informaciones	intelligenza	intelligence	Intelligenz; Nachricht
interdict	interdecir	interdetto	interdire	sperrn
interrogation	interrogacion	interroga- zione	interrogation	Ausfragen; verhoren

English	Spanish	Italian	French	German
jet	surtidor	getto	jet	Duse
knife	cuchillo	coltello	couteau	Messer
land	tierra; terreno	terra	terre	Land
leader	lider	comandante	conducteur; chef	Fuhrer
liaison	enlace	collegamento	liaison	Verbindung
lieutenant	teniente	tenente	lieutenant	Leutnant
lieutenant	teniente	tenente	lieutenant-	Oberstleutnant
colonel	coronel	colonnello	colonel	
line	linea; raya	linea	ligne	Linie
machine gun	ametralladora	mitraglia- trice	mitrailleuse	Maschinenge- wehr
magazine	cargador; deposito	magazzino	magasin	Magazin
main	principal	principale	principal	Haupt
major	mayor	maggiore	commandant	Major
maneuver	maniobra	manovra	manoeuvrer	Manover
map	mapa	carta	carte	Karte
march	marcha	marcia	marche	Marsch
master	suboficial	Oberfeldwebel
sergeant	(USA)			
mechanized	mecanizado	meccanizzato	mecanise	mechanisierte
medical corps	cuerpo facultativo de Sanidad Militar	corpo sanitario militare	service de sante	Sanitatskorps
meet	encontrar	begegnen
meeting	encuentro	Begegnungsge- fecht
engagement				
message	mensaje	messaggio	message	Meldung
middle	medio	mezzo	central	Mitte
military	militar	militare	militaire	militarisch
mine	mina	mina	mine	Mine
misfire	falla	scatto a vuoto	rater	Versager
monoplane	monoplano	monoplano	monoplan	Eindecker
morale	moral	morale	Moral	Moral
mortar	mortero	mortaio	mortier	Morser
mortar, trench	lanzaminas	mortaio da trincea	mortier de tranchee	Granatwerfer
motorized	motorizado	motorizzato	motorise	motorisiert
mountain	montana	montagna	montagne	Berg
mountains	montanas	montagne	Gebirge
movement	movimiento	movimento	mouvement	Bewegung
muzzle	boca	bocca; volata	bouche	Mundung
navy	armada; marina de guerra	marina; flotta	marine de guerre	Kriegsmarine
no	no	no	non	nein
north	norte	nord	nord	Nord
nurse	enfermera	infermiere	infirmiere	Kranken- schwester
objective	objetivo	obiettivo	objectif	Ziel; Gefechtsauf- trag
observation	observacion	osservazione	observation	Beobachtung
obstacle	obstaculo	ostacolo	ostacle	Sperre
offensive	ofensiva	offensiva	offensive	Offensive; Angriff

English	Spanish	Italian	French	German
officer	oficial	ufficiale	officier	Offizier
operation	operacion	operazione	operation	Operation
operator	operador	operatore	opérateur	Bediener
opposition	oposicion	opporzione	opposition	Widerstand
order	orden	ordine	ordre	Befehl
ordnance	armamentos	matériel de guerre	Waffenwesen
organization	organizacion	organizza- zione	organisation	Organisation
organized	organizada	organisee	organisierte
outbreak	ataque violento	ouverture	Ausbruch
outpost	puestos avanzados	avamposto	avant-poste	Vorposten
overlay	calco; superpuesto transparente	tacco	calque	Zielspinne
panel	painel	telo-cifra	panneau	Grundtuch
parachute	paracaidas	paracadute	parachute	Fallschirm
parachutist	paracaidista	paracadutista	parachutiste	Fallschirmjäger
pass	permiso	lasciapassare	permis	Pass
password	consigna; contrasena	parola d' ordine	mot de passe	Kennwort
patrol	patrulla	pattuglia	patrouille	Patrouille
pay	paga	soldo	payer	Sold
peaceful	tranquilo	tranquillo	friedlich
penetration	penetracion	penetrazione	Durchschlag
permanent	permanente	permanente	permanent	dauernd
personnel	personal	personale	personnel	Personal
phase line	linea de fase	linea di fase	ligne a atteindre	Gefechtsziel
pilot	piloto	pilota	pilote	Pilot
pioneer	zapador	zappatore	pionnier	Pioneer
pistol	pistola	pistola	pistolet	Pistole
plan	plan; proyecto	piano	plan	Plan; planen
plane	plano; avion	aeroplano	avion	Flugzeug
platoon	seccion	plotone	peloton	Zug
point	punto; punta	punta	point	Spitze
police	policia	polizia	police	Polizei
pontone	ponton	pontone	ponton	Ponton
port	puerto	porto	port	Hafen
portable	portatil	portabilita	mobile	tragbar
position	posicion	posizione	position	Stellung
post	puesto	posta	poste	Posten
powder	polvora	polvere	poudre	Pulver
prepare	preparar	preparare	preparer	zubereiten
primed	zundfertig
primer	estopin	cannello	amorce	Zundschaube
prisoner	prisionero	prigioniero	prisonnier	Gefangener
private	soldado	soldato	soldat de	Soldat
private	soldado de	semplice	2eme classe	
first class	primera clase (USA)	soldato scelto	soldat de premiere clase	Obersoldat
propaganda	propaganda	propaganda	propagande	Propaganda
propellant	esplosivo di lancio	propulseur	Treibmittel
propeller	propulsore	helice	Propeller
propelling	carga de	charge
charge	proyeccion		propulsive	
pursuit	persecucion	inseguimento	poursuite	Verfolgung

English	Spanish	Italian	French	German
push	empujar	spinta; offensiva su larga scala	poussee	Vorstoss
quartermaster	intendente	intendente	officier de l'intendance	Zeugmeister
question quiet	cuestion quieto	questione quiete	question	Frage Stille; Ruhe; ruhig
radio radio com- munication radio set	radio radiocomuni- cacion aparato de radio	radio stazione radiocampale	radio poste	Radio; Rundfunk Funkverbindung Funk apparat; Funkgerat
railroad rally rallying point	ferrocarril reagrupar punto de reagrupa- miento	ferrovia zona di raccolta	voie feree rallier point de ralliement	Eisenbahn Versammlung Sammelpunkt
range rank	alcance rango; grado	portata grado	portee grade	Schussweite Rang
rapid ration rear rear guard	rapido racion retaguardia retaguardia	rapido razione coda retroguardia	rapide ration arriere, arriere-garde	schnell Verpflegung Hintergrund Nachhut
receiver reconnaissance	receptor reconoci- miento	ricevitore ricognizione	recepteur reconnaissance	Empfanger Aufklarung
regiment reinforce reorganize	regimiento reforzar reorganizar	reggimento rinforzare riorganiz- zare	regiment renforcer reorganiser	Regiment Verstarkung umgruppieren
replacement	reemplazo	ricambio	remplacement	Ersatz; Nachschub
reserve resistance revetment revolver rifle right river road	reserva resistencia revestimiento revolver fusil recto rio camino; via	riserva resistenza rivestimento revolver fucile destra fiume strada	reserve resistance revetement revolver fusil droite riviere route	Reserve Widerstand Bekleidung Revolver Gewehr; Buchse Recht Fluss; Strom Strasse
rocket route roving gun	cohete ruta; via canon nomada	razzo itinerario	fusee route piece nomade	Rakete Weg Wandergeschutz
saddle (top) safe salient salvo scale scout to scout sea searchlight second lieutenant secret section	depression seguro saliente salva escalar explorador explorar mar projector segundo teniente secret seccion salvo saliente salva scala esploratore esplorare mare proiettore sottotenente segreto sezione	col sauf saillant salve echelle eclairer reconnaitre mer projecteur sous-lieutenant	Sattel sicher Ausbuchtung Salve Masstab Spaher spahen Meer Scheinwerfer Leutnant geheim Section; Abteilung Sektor Sicherheit
sector security	sector seguridad	settore sicurezza	secteur surete	Sektor Sicherheit

English	Spanish	Italian	French	German
seize	capturar	impadronirsi	saisir	erfassen
sentinel	centinela	sentinella	sentinelle	Posten
sentry post	puesto de centinela	Wachposten
sergeant	sargento	sergente	sergent	Unteroffizier
shell	granada	granata	obus	Geschoss
to shell	bombardear	bombardare	bombarder	beschiessen
shelter	refugio	ricovero	abri	Schutzraum
shield	escudo	scudo	bouclier	Schild
ship	buque	nave	navire	Schiff
shore	costa	costa	bord	Kuste
shot	disparo	colpo	coup	Schuss
shrapnel	shrapnel	shrapnel	shrapnel	Schrapnell
sick	enfermo	malato	malade	krank
siege	sitio	assedio	siege	Belagerung
sign	signo	segno	signe	Zeichen
signal	sena	segnale	signal	Signal
situation	situacion	situazione	situation	Lage
ski	esqui	sci	ski	Ski
skirmish	escaramuza	scaramuccia	escarmouche	Scharmützel
sled	trineo	slitta	traineau	Schlitten
slit-trench	trinchera-abrigo	tranchee-abri	Fliegerschutzengraben
small	pequeno	portatili	petit	klein
smoke	humo	fumo	fumee	Rauch
soldier	soldado	soldato	soldat	Soldat
sortie	salida	sortita	sortie	Ausfall
sound	sonido	suono	son	Schall
south	sur	sud	sud	Suden
spearhead	cabeza de ataque	punta di lancia	pointe	Stossgruppe
speed	velocidad	velocita	vitesse	Geschwindigkeit
squadron (Avn)	escuadrilla	squadriglia	escadrille	Staffel
staff	estado mayor	stato maggiore	etat-major	Stab
stalemate	situation sin salida	stallo	Gleichgewichtslage
standard	standard	stendardo	normale	normal
start	comienzo	inizio	commencement	Anfang
stone	pedra	pietra	pierre	Stein
stores	provisiones	provviste	provisions	Vorrat
storm	asaltar	assalto	orage	Ersturmung
straggler	rezagado	sbandato	trainard	Nachzügler
strategy	estrategia	strategia	strategie	Strategie
stream	corriente; arroyo	corrente; fiotto	ruisseau	Bach
strength	fuerza; efectivo	forza	effectif	Starke
strong	fuerto	forte	fort	stark
strongpoint	punto de resistencia	caposaldo	point de force	Schwerpunkt
submarine	submarino	sommergibile	sous-marin	Unterseeboot
subordinate	subalterno	subordinato	subordonne	unterstellt
success	buen exito	successo	succes	Erfolg
supplement	suplemento	supplemento	Erganzung
supply	abastecimiento	approvvigionamento	ravitaillement	Nachschub
support	apoyo	appoggio	soutien	Unterstützung
surrender	capitulacion	resa	capitulation	Waffenstreckung
survey	reconocimiento topografico	arpentage	Vermessung
system	sistema; metodo	sistema	systeme	System
tactical	tactico	tattico	tactique	taktisch
tactics	tactica	tattica	tactique	Taktik

English	Spanish	Italian	French	German
tank	tanque	carro armato	char	Panzerkampfwagen
target	blanco	bersaglio	cible	Ziel
task	tarea	compito	ouvrage	Aufgabe
task force	agrupacion tactica de fuerzas para una mission especial (USA)	groupement strategique mixte	Verband
telegraph	telegrafo	telegrafo	telegraphe	Telegraph
telephone	telefono	telefono	telephone	Telephon
tent	tienda de campana	tenda	tente	Zelt
terrain	terreno	terreno	terrain	Gelände
territory	territorio	territorio	territoire	Gebiet
thick	grueso	grosso	dick
thin	delgado	magro	dunn
threat	amenaza	minaccia	menace	Drohung
timber	madera de construccion	legname	bois de construction	Bauholz
time	tiempo	tempo	temps	Zeit
tool	herramienta	attrezzo	outil	Gerat
topography	topografia	topografia	topographie	Gelandekunde
torpedo	torpedo	siluro	torpille	Torpedo
tow	estopa	rimorchio	remorque	Tau
to tow	remolcar	rimorchiare	remorquer	schleppen
tractor	tractor	trattrice	tracteur	Schlepper
traffic	trafico	traffico	trafic	Verkehr
trailer	remolque	retrotreno	fourgon	Anhanger
train	tren	treno	train	Zug
transmit	transmitir	trasmettere	transmettre	ubertragen
transport	transporte	trasporto	transport	Transport
transportable	transportable	transportfahig
trap	trampa	trappola	piege	Falle
traverse	punteria en direccion	spostamento	traverse	Querzug; durchqueren
trench	trinchera	trincea	tranchee	Graben
tripod	tripode	treppiede	trepifuss	Dreifuss
troops	tropas	truppe	troupes	Truppen
truck	camion	autocarro	camion	Lastkraftwager
tube	tubo	tubo	tube	Rohr
tunnel	tunel	galleria	tunnel	Tunnel
turret	torreta	torre	tourelle	Turm
uniform	uniforme	uniforme	uniforme	Uniform; einheitlich
unit	unidad	reparto	unite	Einheit
unload	descargar	scaricare	decharger	entladen
up	arriba	auf
use	uso	uso	usage	Gebrauch
vacant	vacio	voto	unbesetzt
vehicle	vehiculo	veicolo	vehicule	Fahrzeug
vertical	vertical	verticale	vertical	senkrecht
victor	vencedor	vincitore	Sieger
victory	victoria	vittoria	victoire	Sieg
village	aldea	villaggio	village	Dorf
wagon	carro; carreta	carriaggio; vagone	fourgon; voiture	Wagen
wait	espera	aspettare	warten
walk	marcha	passaggio	marche; promenade	gehen
wall	pared; muro	muro	mur	Mauer
war	guerra	guerra	guerre	Krieg

English	Spanish	Italian	French	German
warning	alarma	avvertimento	alerte	Warnung
warship	buque de guerra	vascello da guerra	navire de guerre	Kriegsschiff
watch	cuarto	guardia	garde	Wache
water	agua	acqua	eau	Wasser
wave	ola; onda	onda	vague	Welle
way	via	via	chemin	Weg
we	nosotros	noi	wir
weak	debil	debole	faible	schwach
weapon	arma	arma	arme	Waffe
weather	tiempo	tempo	temps	Wetter
wedge	cuna	cuneo	coin	Keil
west	oeste	ovest	ouest	Westen
wheel	rueda	ruota	roue	Rad
when	cuando	quando	wann
where	donde	dove	wo
why	por que	perche	warum
wing	ala	ala	aile	Flugel
wire	alambre; hilo	filo	fil	Draht
withdraw	replegarse	ripiegarsi	replier	zuruckziehen
wood	bosque	bosco; legno	bois	Holz; Wald
wooded	bosque	boschivo	boise	bewaldet
work	trabajo	opera	ouvrage	Werk; Arbeit; arbeiten
works	trabajos	opere	ouvrages	Werke
workshop	taller	officina	Werkstatt
zone	zona	zona	zone	Gebiet; Zone
combat zone	zona de combate	zona di guerra	zone de l'avant	Kampfgbiet
defensive zone	zona de defensa	zona di difensivo	zone de defense	Verteidigungszone

2. NUMERALS. a. Cardinal numbers.

English	Spanish
One	Uno
Two	Dos
Three	Tres
Four	Cuatro
Five	Cinco
Six	Seis
Seven	Siete
Eight	Ocho
Nine	Nueve
Ten	Diez
Eleven	Once
Twelve	Doce
Thirteen	Trece
Fourteen	Catorce
Fifteen	Quince
Sixteen	Dieciseis, Diez y seis
Seventeen	Diecisiete, Diez y siete
Eighteen	Dieciocho, Diez y ocho
Nineteen	Diecinueve, Diez y nueve
Twenty	Veinte
Twenty-one	Veintiuno, Veinte y uno
Thirty	Treinta
Thirty-one	Treintiuno, Treinta y uno
Forty	Cuarenta
Forty-one	Cuarentiuno, Cuarenta y uno
Fifty	Cincuenta

English

Fifty-one
Sixty
Sixty-one
Seventy
Seventy-one
Eighty
Eighty-one
Ninety
Ninety-one
Hundred
Thousand
Million
One billion
One trillion

Spanish

Cincuentuno, Cincuenta y uno
Sesenta
Sesentiuño, Sesenta y uno
Setenta
Setentiuño, Setenta y uno
Ochenta
Ochentiuño, Ochenta y uno
Noventa
Noventiuño, Noventa y uno
Cien, Ciento (Cien before noun)
Mil
Un millon
Mil millones
Un billon

b. Ordinal numbers.

First
Second
Third
Fourth
Fifth
Sixth
Seventh
Eighth
Ninth
Tenth
Eleventh
Twelfth
Thirteenth
Fourteenth
Fifteenth
Sixteenth
Seventeenth
Eighteenth
Nineteenth
Twentieth
Twenty-first
Thirtieth
Thirty-first
Fortieth
Forty-first
Fiftieth
Fifty-first
Sixtieth
Sixty-first
Seventieth
Seventy-first
Eightieth
Eighty-first
Ninetieth
Ninety-first
Hundredth
Thousandth
Millionth

Primero
Segundo
Tercero
Cuarto
Quinto
Sexto
Septimo
Octavo
Noveno
Decimo
Undecimo
Duodecimo
Decimotercero
Decimocuarto
Decimoquinto
Decimosexto
Decimoseptimo
Decimooctavo
Decimonoveno
Vigesimo
Vigesimo primero
Trigesimo
Trigesimo primero
Cuadragésimo
Cuadragésimo primero
Quincuagesimo
Quincuagesimo primero
Sexagesimo
Sexagesimo primero
Septuagesimo
Septuagesimo primero
Octogesimo
Octogesimo primero
Nonagesimo
Nonagesimo primero
Centesimo
Milesimo
Millonesimo

Section II. AGGRESSOR—ENGLISH

Aggressor

abastecimiento
abbattuta
Ablenkungsangriff
abri
abschieben

English

supply
abatis
feint
shelter
evacuate

Aggressor	English
Abteilung	detail, detachment, section
Abwehr	defense
accendere	ignite
accerchiare	encircle
accion	action
accion dilatoria	delaying action
acqua	water
action retardrice	delaying action
adiacente	adjacent
adjoint	adjutant
adunata	assembly
adyacente	adjacent
aerea	aerial
aereo	aerial
aerien	aerial
aerienne	air
aeroplane	airplane
aeroplano	airplane
afosarse	to dig in
agrupacion tactica de fuerzas para una mision especial	task force
agua	water
aide	helper, assistant
aile	wing
air	air
aire	air
aiutatore	helper
Aktion	action
ala	wing
alambre	wire
alarma	warning
alcance	range
aldea	village
alerta	alert
alerte	warning, alert
alerter	alert
all'erta	alert
alto	halt, high
amago	feint
ambulancia	ambulance
Ambulanz	ambulance
ambulanza	ambulance
amenaza	threat
ametrallador	machine gunner
ametralladora	machine gun
amichenole	friendly
amies	friendly
amigable	friendly
amorce	primer
Anfang	start, begin
angrenzend	adjacent
Angriff	assault, attack
Anhanger	trailer
antiaereo	antiaircraft
antiaerien	antiaircraft
anticarro	antitank
antichars	antitank
antitanque	antitank
aparato de radio	radio set
apoyo	support
appareil photographique	camera
appoggio	support
approvvigionamento	supply
apuntador	gunner
Arbeit	work
arbeiten	work

Aggressor	English
afia	air
arma	arm, weapon
armada	navy
armamentos	ordnance
arme	arm, weapon
Armee	army
armer	arm
arcentage	survey
arriba	up
arriere	rear
arriere garde	rear guard
arroyo	stream
artigliere	gunner
artiglieria	artillery
artilleria	artillery
Artillerie	artillery
artillero	cannoneer, gunner
asaltar	storm
asalto	assault
asamblea	assembly
asistente	helper
aspettare	wait
assalto	assault, storm
assaut	assault, storm
assediare	besiege
assedio	siege
assieger	besiege
Astverhau	abatis
asintos civil	civil affairs
ataque	attack
ataque violento	outbreak, violent attack
atrincheramiento	earthwork
attacco	attack
attaque	attack
atteindre	hit
attrezzo	tool
auf	up
Aufgabe	task
Aufklärung	reconnaissance
Aufmarsch	concentration
Aufschlag	impact
aitante	adjutant
Ausbruch	outbreak
Ausbuchtung	salient
Ausfragen	interrogation, to question
ausgraben	excavate
ausscheiden	eliminate
Auszeichnung	decoration
auto	car
autocarro	truck
avamposto	outpost
avance	advance
avancer	advance
avant poste	outpost
avanzata	advance
aviacion	aviation
aviador	aviator
aviateur	aviator
aviatore	aviator
aviazione	aviation
avion	plane
avvertire	warning
avviluppamento	envelopment
avviluppare	envelop
avvolgimento di ambedue le ali	double envelopment
ayudante	adjutant

Aggressor	English
azione	action
Bach	stream, brook
bajas	casualties
bala	bullet
balle	bullet
Ballon	balloon
bandera	flag
bandiera	flag
barrera	barrage, barrier
barriera	barrier
barriere	barrier, fence
bataille	battle
batailleur avion de chasse	fighter plane
Bataillon	battalion
batalla	battle
batallon	battalion
batardeau	dam
bateria	battery
battaglia	battle
battaglione	battalion
batteria	battery
Batterie	battery
bauen	construct
Bauholz	timber
Baumverhau	abatis
Bediener	operator
Befehl	order
befestigen	fortify
begegnen	meet
begegnungsgefecht	meeting engagement
begehen	commit
Bekleidung	revetment
belagern	besiege
Belagerung	siege
bemannung	crew
Benzin	gasoline
benzina	gasoline
Beobachtung	observation
Bereitschaft	alert
Berg	mountain
bersaglio	target
beschiessen	to shell
betrogen	deceive
Bewegung	movement
Bezirk	district
blanco	target
blindage	armor
blocco	blockade
bloc de culasse	breechblock
blocqueo	blockade
hlocus	blockade
boca	muzzle
bocca	muzzle
bois	wood
bois de construction	timber
boise	wooded
bomba	bomb
bombardare	to shell
bombardear	to shell
Bombe	bomb
borgnese	civilian
boschivo	wooded
bosco	wood
bosque	wood, wooded
bouche	muzzle
bouclier	shield

Aggressor	English
Brandstifter	incendiary
brevet	commission
brigada	brigade
brigata	brigade
Bruckenkopf an feindlicher Kuste	beachhead
brujula	compass
buca da tiratore	fox hole
buen exito	success
buque	ship
buque de guerra	warship
bussola	compass
caballeria	cavalry
caballo	horse
cabeza de ataque	spearhead
cabeza de playa	beachhead
cabo	cable, corporal
cachar	conceal
calco	overlay
calibre	caliber
calibro	caliber
calque renseigne	overlay
camara fotografica	camera
camino	road
camion	truck
campagna	campaign
campagne	campaign
campamento	camp
campana	campaign
campement	camp
campo	camp, field
canna	barrel
cannello	primer
cannello fulminante	igniter
cannone	cannon, gun
canon	barrel, cannon, gun
canon nomada	roving gun
capitaine	captain
capitan	captain
capitano	captain
capitolare	capitulate
capitulacion	surrender
capitular	capitulate
capitulation	surrender
capituler	capitulate
caporal	corporal
caporale	corporal
caposaldo	strongpoint
capturar	capture, seize
carabina	carbine
carabine	carbine
carga	charge
carga de proyeccion	propelling charge
cargador	magazine
carica	charge
carreta	wagon
carriaggio	wagon
carro	car, wagon
carro armato	armored car, tank
carta	map
carte	map
cartouche	cartridge
cartuccia	cartridge
cartucho	cartridge
casamata	casemate
casamatta	casemate

Aggressor	English
casco	helmet
cassone	caisson
cattura	capture
cavalerie	cavalry
cavalleria	cavalry
cavallo	horse
cavar	dig
cavo	cable
cebo	igniter
cementerio	cemetery
centinela	sentinel
central	middle
cerca	fence
cerca de alambre	wire fence
cercle	circle
champ	field
char	tank
charge d'inflammation	igniter
Chef	chief, leader
chemin	way
cheuron	chevron
cheval	horse
cible	target
cierre	breechblock
cimetiere	cemetery
cimitero	cemetery
circolo	circle
circulo	circle
citta	city
ciudad	city
civil	civilian
cocinero	cook
coda	rear
cohete	rocket
cohete de iluminacion	flare
coin	wedge
col	saddle (top)
colina	hill
collegamento	liaison
collina	hill
colline	hill
colonna	column
colonne	column
colonnello	colonel
colpo	hit, shot
coltello	knife
columna	column
comandante	commander, leader
comando	command
combate	combat
combatiente	fighter
combattente	fighter
combattimento	combat
comienzo	start
comision	commission
commandant	commander, lieutenant colonel
commandement	command
commencement	start
commissione	commission
compagnia	company
compagnie	company
compas	compass
compito	task
comunicacion	communication
comunicazione	communication
conca	hollow

Aggressor	English
concentracion	concentration
concentrazione	concentration
condecoracion	decoration
conducateur	leader
consejo de guerre	court-martial
consigna	password
construccion	construction
construire	construct
costruzione	construction
constuir	construct
constuire	construct
contorno	contour
contraataque	counterattack
contrasegna	countersign
contrasena	password
contrassegno	countersign
contrattacco	counterattack
contre-attaque	counterattack
contree	country
contre-mot	countersign
controllo	control
coraza	armor
coronel	colonel
corpo	corps
corpo sanitario militare	medical corps
corrazza	armor
corrente	stream
corriente	stream
corte marziale	court-martial
costa	shore
coteau	hill
coup	shot
cour martiale	court-martial
couteau	knife
couvert	cover
cozzo	impact
creuser	dig
creuser des tranches	to dig in
creux	hollow
cuando	when
cuartel general	headquarters
cuarto	watch
cuchillo	knife
cuerpo	corps
cuerpo facultativo de Sanidad	medical corps
Militar	
question	question
cuisinier	cook
cuna	wedge
cuneo	wedge
cuoco	cook
Damm	dam
data	date
Datum	date
dauernd	permanent
debil	weak
debole	weak
debordement par les deux flancs	double envelopment
decharger	unload
Deckung	cover
decorazione	decoration
de débarquement	beachhead
defaite	defeat
defensa	defense

Aggressor	English
de grande route	highway
de l'intendance	quartermaster
demolicion	demolition
demolizione	demolition
densidad	density
densita	density
densite	density
departamento	department
deposito	dump
deposito provisional	dump
depression	saddle (top)
derrota	defeat
derrotar	to defeat
desastre	disaster
descargar	unload
deserteur	deserter
desertor	deserter
desplegar	develop
destacamento	detachment
destra	right
detachment	detail, detachment
detonador	detonator
detonante	detonator
detonare	detonate
detonateur	detonator
detonation	blast, detonation
detoner	detonate
detonieren	detonate
developper	develop
devoir	duty
dia	day
Dichtigkeit	density
dick	thick
Dienst	duty
difesa	defense
diga di sbarramento	dam
dipartimento	department
direccion	direction
direzione	direction
diriger	control
disastro	disaster
disciplina	discipline
disertore	deserter
disparo	shot
distaccamento	detachment
distancia	distance
distanza	distance
distretto	district
Disziplin	discipline
divisione	division
documento	document
éonde	where
doppelte umfangung	double envelopment
Dorf	village
dotacion del canon	gun crew
dove	where
Draht	wire
Drahtwalze	concertina
drahtzaun	wire fence
drapeau	flag
drappello	detail
Dreifuss	tripod
Drohung	threat
droite	right
Dunkelheit	darkness
dunn	thin

Aggressor	English
durchqueren	traverse
Durchschlag	penetration
Duse	jet
eau	water
echelle	scale
eclairante	flare
efectivo	effective, strength
effectif	strength
effettivo	effective
efficace	effective
eilig	hasty
Eindecker	monoplane
ingraben	to dig in
Einheit	unit
einheitlich	uniform
Eis	ice
Eisenbahn	railroad
ejercito	army
elements de poursuite strategique	encircling force
eliminar	eliminate
eliminar	eliminate
elmetto	helmet
Empfanger	receiver
emplazamiento	emplacement
emplazar	emplace
empuje	push
encender	ignite
encercler	encircle
enchevetrement	entanglement
encontrar	encounter
encuentro	engagement, meeting engagement
enemigo	enemy
enfermera	nurse
enfermo	sick
enflammer	ignite
enganar	deceive
enlace	liaison
ennemi	enemy
Entfernung	distance
entladen	unload
entwickeln	develop
enveloppement	envelopment
enveloppe	envelop
envolver	envelop
envolvimiento	envelopment
envolvimiento doble	double envelopment
equipaggiamento	equipment
equipe	crew
equipment	equipment
equipo	equipment
erdwerke	earthwork
erfassen	seize
Erfolg	success
Erganzung	supplement
Erkennung	identification
Ersturmung	storm
escadrille	squadron (AVN)
escalar	scale
escalon	echelon
escaramuza	skirmish
escarmouche	skirmish
escuadrilla	squadron (AVN)
escudo	shield
esercito	army
espera	wait

Aggressor	English
esplorare	to scout
esplorator	scout
esplosivo di lancio	propellant
espoleta	fuze
esqui	ski
essence	gasoline
est	east
estado mayor	general staff, staff
-estellar	detonate
este	east
estopa	tow
estrategia	strategy
etat-major	general staff, staff
evacuar	evacuate
evacuare	evacuate
evacuer	evacuate
excavar	excavate
excaver	excavate
explorador	scout
explorar	to scout
Fahne	flag
Fahrzeug	vehicle
faible	weak
falla	misfire
falle	trap
Fallschirm	parachute
Fallschirmjager	parachutist
fanteria	infantry
fecha	date
Feind	enemy
feindlich	hostile
feinte	feint
Feld	field
Feldwebel	first sergeant
Feldzug	campaign
fermata	halt
ferrocarril	railroad
ferrovia	railroad
Festung	fortification
feu	fire
Feuer	fire
fianco	flank
fil	wire
fila	file
filo metallico	wire
finta	feint
fume	river
Flammenwerfer	flamethrower
flanc	flank
flanco	flank
Flanke	flank
Flanken	flank
flanquear	flank
flanquer	flank
fliegen	fly
Flieger	aviator
Fliegerschutzengraben	slit trench
flotta	navy
Flug	flight
Flugabwehr	antiaircraft
Flugel	wing
Flugwesen	aviation
Flugzeug	plane, airplane
fluide	fluid
fluido	fluid

Aggressor	English
Fluss	river
Flussigkeit	fluid
fogonazo	gun flash
formacion	formation
formazione	formation
forte	strong
fortificacion	fortification
fortificar	fortify
fortificare	fortify
fortificazione	fortification
fortifier	fortify
forza	force, strength
forze accerchianti	encircling force
forze armate	armed forces
foso	ditch
fosse	ditch
fosso	ditch
fourgon	trailer, wagon
fraccion	detail
Frage	question
frente	front
freundlich	friendly
friedlich	peaceful
fronte	front
Fuchsloch	fox hole
fucile	rifle
fuego	fire
fuerto	strong
fuerza	force, strength
fuerza envolvente	enveloping force
Fuhrer	leader
fumee	smoke
fumo	smoke
Funk apparat	radio set
Funkgerat	radio set
Funkverbindung	radio communication
Furt	ford
fusee	fuse
fusees	rocket
fusil	rifle
gallone	chevron
garde	watch
Gas	gas
Gaskrieg	chemical warfare
gasolina	gasoline
gaz	gas
Gebiet	area, territory, zone
Gebirge	mountains
Gebrauch	use
Gefahr	danger
Gefangener	prisoner
Gefangenmahme	capture
Gefecht	engagement
Gefechtsziel	phase line
gegen Sicht decken	conceal
geheim	secret
gehen	walk
Gelände	terrain
Gelandekunde	topography
General	general
general	general
general de brigada	brigadier general
general de brigade	brigadier general
generale	general
Generale di Brigata	brigadier general

Aggressor	English
Generalmajor	brigadier general
Generalstab	general staff
genie	engineer
geniere	engineer
Gerat	equipment, tool
Geschoss	shell
Geschutz	gun
Geschutzbedienung	gun crew
Geschwindigkeit	speed
getto	jet
Gewehr	rifle
ghiaccio	ice
giorno	day
glace	ice
Gleichgewichtslage	stalemate
gliederung	formation
globo	balloon
Graben	ditch, trench
graben	dig
grade	rank
grado	rank
granada	grenade, shell
granada de mano	hand grenade
granata	grenade, shell
granata di mano	hand grenade
Granate	grenade
granatiere	grenadier
granatwerfer	trench mortar
grenade	grenade
grenade a main	hand grenade
grenadier	grenadier
Grenze	boundary
grosso	thick
groupe	group, section
groupement strategique mixte	task force
grueso	thick
Grund	ground
Grundtuch	panel
grupo	group
gruppe	group
gruppo	group
guado	ford
guardia	watch
gue	ford
guerra	war
guerra Chimica	chemical warfare
guerra quimica	chemical warfare
guerre	war
guerre chimique	chemical warfare
hacer explosion	detonate
Hafen	port
Halt	halt
halte	halt
Handgranate	hand grenade
harcelar	harass
Haubitze	howitzer
Haupt	chief, main
Hauptmann	captain
Hauptquartier	headquarters
Hauptstrasse	highway
haut	high
Heer	army
Helfer	helper
helice	propellor
Helm	helmet

Aggressor	English
herramienta	tool
heure	hour
hielo	ice
hilera	file
hilo	wire
hinhaltendes gefecht	delaying action
Hintergrund	rear
hoch	high
hohl	hollow
Holz	wood
hopital	hospital
hora	hour
hors de combat	disabled
hospital	hospital
Hostigar	harass
hostil	hostile
hueco	hollow
Hugel	hill
humo	smoke
identificacion	identification
identificazione.	identification
impacto	impact
impadronirsi	seize
inabilitato	disabled
incendiaire	incendiary
incendiario	incendiary
independiente	independent
indipendente	independent
infanteria	infantry
Infanterie	infantry
infanterie	infantry
infermiere	nurse
informaciones	intelligence
ingannare	deceive
ingeniero	engineer
inizio	start
inseguimento	pursuit
in Stellung bringen	emplace
Intelligenz	intelligence
intelligenza	intelligence
intendente	quartermaster
interdecir	interdict
interdetto	interdict
interdire	interdict
interrogacion	interrogation
interrogazione	interrogation
itinerario	route
inutilizado	disabled
invalido	disabled
jet	jet
jour	day
Kabel	cable
Kaliber	caliber
Kamera	camera
Kampf	battle, combat
Kampfer	fighter
Kampffront	front-line
Kampfgebiet	combat zone
Kampfstoff	gas
Kanone	cannon
Kanonier	cannoneer
kapitulieren	capitulate
Karabiner	carbine

Aggressor	English
Karte	map
Kartenzeichen	conventional signs
Kasematte	casemate
Kavallerie	cavalry
Keil	wedge
Kennwort	password
klein	small
koaxial	coaxial
Koch	cook
Kolonne	column
Kommandant	commander
Kommando	command
Kommandostelle	command post
Kommission	commission
Kompanie	company
Kompass	compass
Konstruktion	construction
Kontrolle	control
Kontur	contour
Korps	corps
Kraftstoff	fuel
krank	sick
Krankenschwester	nurse
Kreis	circle
Krieg	war
Kriegsgericht	court martial
Kriegsmarine	navy
Kriegsschiff	warship
Kriegsverluste	casualties
Kugel	bullet
Küste	shore
Ladung	charge
Lage	situation
Lager	camp, dump
lance-flammes	flame thrower
lancia-fiamme	flame thrower
Land	country, land
lanzallamas	flame thrower
lanzaminas	trench mortar
lasciapassare	pass
Lastkraftwagen	truck
Lauf	barrel
lavoro	work
Lazarett	hospital
legname	timber
legno	wood
Leutenant	second lieutenant
Leutnant	lieutenant
lichtsignal	flare
lider	leader
lieutenant	lieutenant
lieutenant	first lieutenant
lieutenant-colonel	lieutenant colonel
ligne	line
ligne a atteindre	phase line
limite	boundary
linea	line
linea de fase	phase line
linea de fronte	front line
linea del frente	front line
linea di fase	phase line
Linie	line
luce del giorno	daylight
lueur	flash
Luft	air

Aggressor	English
luz deldia	daylight
luz de senal	flare
macchina fotografica	camera
madera de construccion	timber
magasin	magazine
magazin	magazine
magazzino	magazine
maggiore	major
magro	thin
Major	major
malade	sick
malato	sick
mando	command
maniobra	maneuver
manoeuvrer	maneuver
Manover	maneuver
manovra	maneuver
mapa	map
mar	sea
marcha	march
marche	march
marcia	march
mare	sea
marina	navy
marina de guerra	navy
marine de guerre	navy
Marsch	march
mascherare	conceal
Maschinengewehr	machine gun
Masstab	scale (map)
materiel de guerre	ordnance
Mauer	wall
mayor	major
mecanizadas	mechanized
mecanizado	mechanized
meccanizzato	mechanized
mechanisierte	mechanized
medio	middle
Meer	sea
Meldung	message
menace	threat
mensaje	message
mer	sea
messaggio	message
Messer	knife
metallico	wire
metodo	system
mettre en batterie	emplace
mezzo	middle
militaire	military
militar	military
militare	military
militarisch	military
mina	mine
minaccia	threat
Mine	mine
ministerio	department
mitragliatrice	machine gun
mitrailleuse	machine gun
Mitte	middle
mobile	portable
molestare	harass
monoplan	monoplane
monoplano	monoplane
montagna	mountain

Aggressor	English
montagne	mountain
montana	mountain(s)
montanas	mountains
Moral	morale
moral	morale
morser	mortar
mort	dead
mortaio	mortar
mortaio da trincea	trench mortar
mortero	mortar
mortier	mortar
mot de passe	password
motorise	motorized
motorisiert	motorized
motorizado	motorized
motorizzato	motorized
mouvement	movement
movimento	movement
movimiento	movement
muerto	dead
Mundung	muzzle
mundungsfeuer	flash
municion	ammunition
Munition	ammunition
munitions	ammunition
Munitionswagen	caisson
munizioni	ammunition
mur	wall
muro	wall
Nachricht	communication, intelligence
Nachschub	replacement, supply
Nachzugler	straggler
nein	no
nemico	enemy
Niederlage	defeat
noi	we
non	no
Nord	north
nord	north
normal	standard
normale	standard
norte	north
Oberfeldwebel	master sergeant
Obergefreiter	corporal
Oberleutnant	first lieutenant
Obersoldat	private first class
Oberstleutnant	lieutenant colonel
obice	howitzer
obiettivo	objective
objectif	objective
objetivo	objective
obscuridad	darkness
obscurite	darkness
obstaculo	obstacle
obstaculo de alambres	entanglement
obus	howitzer, shell
obusier	howitzer
oculto	conceal
oeste	west
ofensiva	offensive
offensiva	offensive
offensiva su larga scala	push
offesa	offensive
officier	officer

Aggressor	English
officina	workshop
offizier	officer
oficial	officer
ola	wave
onda	wave
opera	work (s)
operacion	operation
operador	operator
opérateur	operator
operatore	operator
operazione	operation
oposicion	opposition
opporizione	opposition
ora	hour
orage	storm
orden	order
ordine	order
ordre	order
organisee	organized
organisieren	organized
organizacion	organization
organizada	organized
organizzazione	organization
oscurita	darkness
ospedale	hospital
Ost	east
ostacolo	obstacle
ostile	hostile
ouest	west
outil	tool
ouverture	outbreak
ouvrage, (s)	task, work (s)
ovest	west
paese	country
paga	pay
painel	panel
pais	country
pallone	balloon
pallottola	bullet
panneau	panel
Panzer	armor
Panzerabwehr	antitank
Panzer Kampfwagen	tank
paracadute	parachute
paracadutista	parachutist
paracaidas	parachute
paracaidista	parachutist
parachute	parachute
parachutiste	parachutist
pared	wall
parola d'ordine	password
Parole	countersign
paso de rio	ford
Pass	pass
passeggio	walk
Patrone	cartridge
Patrouille, patrouille	patrol
patrulla	patrol
pattuglia	patrol
payer	pay
pegar	hit
peligro	danger
peloton	platoon
penetracion	penetration
pentrazione	penetration

Aggressor	English
péqueno	small
perche	why
perdite	casualties
pericolo	danger
permanent	permanent
permanente	permanent
permis	pass
permiso	pass
persecucion	pursuit
Personal, personal	personnel
personale	personnel
personnel	personnel
pertes	casualties
petit	small
Pferd	horse
piano	plan
piece nomada	roving gun
piedra	stone
piege	trap
pierre	stone
pietra	stone
Pilot	pilot
pilota	pilot
pilote	pilot
piloto	pilot
Pionier	pioneer
pionnier	pioneer
pistola	pistol
Pistole	pistol
pistolet	pistol
Plan, plan	plan
planen	plan
plano	plane
plotone	platoon
point	point
pointage	aiming
point de force	strong point
point de ralliement	rallying point
pointe	spearhead
pointer	aim
pointeur	gunner
police	police
policia	police
Polizei	police
polizia	police
polvere	powder
polvora	powder
Ponton, ponton	ponton
pontone	ponton
por que	why
port	port
portabilita	portable
portata	range
portatil	portable
portatili	small
portee	range
porteur	carrier
porto	port
posicion	position
posicion improvisada	hasty position
position	position
posizione	position
posta	post
postare	emplace
postazione	emplacement
poste	post

Aggressor	English
poste de commandement	command post
poste de rassemblement des eclopes	collecting point
poste de secours	dressing station
Posten	post, sentinel
posto di medicazione	dressing station
posto raccolta feriti	collecting point
oudre	powder
poussee	push
pozo de tirador	fox hole
premiere ligne	front line
preparar	prepare
preparare	prepare
preparer	prepare
presto	hasty
prigioniero	prisoner
primera linea	front line
primero	chief
primer teniente	first lieutenant
principal	main
principale	chief, main
prisonero	prisoner
prisonnier	prisoner
profondeur	depth
profondita	depth
profundidad	depth
proiettore	searchlight
projecteur	searchlight
promenade	walk
pronto	hasty
Propaganda, propaganda	propaganda
propagande	propaganda
Propeller	propeller
propulseur	propellant
propulsore	propeller
proteccion	cover
provisiones	stores
provisions	stores
provisoire	dump
provviste	stores
proyecto	plan
proyector	searchlight
puerto	port
puesto	post
puesto de centinda	sentry post
puesto de mando	command post
puesto de socorro	dressing station
puestos avanzados	outpost
Pulver	powder
punt	aim
punta	point
punta di lancia	spearhead
puntamento	aiming
punteria	aim, aiming
punteria en direccion	traverse
punto	point
punto de agrupamiento	collecting point
punto de reagrupamiento	rallying point
punto de resistencia	strong point
pursuite	pursuit
quando	when
quartier general	headquarters
quartiere generale	headquarters
Querzug	traverse
question	question

Aggressor	English
questione	question
quiete	quiet
quieto	quiet
raçion	ration
Rad	wheel
radio	radio
radio comunicacion	radio communication
Rakete	rocket
rallier	rally
Rang	rank
rango	rank
rapide	hasty, rapid
rapide d'une position	hasty position
rapido	rapid
rassemblement	assembly
rastra	caisson
rater	misfire
ration	ration
Rauch	smoke
ravitaillement	supply
razione	ration
razzo	flare, rocket
reagrupar	rally
rebufo	blast
recepteur	receiver
receptor	receiver
receptor	receiver
Recht	right
recognizione	reconnaissance
reconnaissance	reconnaissance
reconocimiento	reconnaissance
reconocimiento topografico	survey
recovero	shelter
recto	right
reemplazo	replacement
reforzar	reinforce
refugio	shelter
reggimento	regiment
Regiment, regiment	regiment
regimiento	regiment
region	district
region militar	district
Reihe	file
remolcar	to tow
remolque	trailer
remorquer	tow
remplacant	replacement
recontre	encounter
renforcer	reinforce
reorganiser	reorganize
reorganizar	reorganize
reparto	unit
replegarse	withdraw
replier	withdraw
resa	surrender
reseau brun	concertina
reserva	reserve
Reserve, reserve	reserve
resistance	resistance
resistencia	resistance
resistenza	resistance
retaguardia	rear, rear guard
retardar	delay
retarder	delay
reticolato	entanglement, fence, wire

Aggressor	English
retrotreno	trailer
revestimiento	revetment
revetement	revetment
Revolver, revolver	revolver
rezagado	straggler
ricambio	replacement
Richtung	direction
rimorchiare	to tow
rimorchio	tow
rinforzare	reinforce
rio	river
riorganizzare	reorganize
riparo	cover
ripiegarsi	withdraw
riserva	reserve
ritardo	delay
rivestimento	revetment
rivierre	river
rodear	encircle
Rohr	tube
roue	wheel
route	road, route
rueda	wheel
Ruhe	quiet
ruhig	quiet
Rundfunk	radio
ruota	wheel
ruta	route
saillant	salient
saisir	seize
salida	sortie
saliente	salient
salva	salvo
Salve, salve	salvo
salvo	safe
Sammeln	assembly
Sammelpunkt.	collecting point, rallying point
Sanitatskorps	medical corps
sargent-chef	first sergeant
sargento	sergeant
sargento primero	first sergeant
Sattel	saddle (top)
sauf	safe
sbandato	straggler
sbarramento	barrage
scaglione	echelon
scala	scale
scaramuccia	skirmish
scaricare	unload
scatto a vuoto	misfire
scavare	dig
Schall	sound
Scharmützel	skirmish
Scheinwerfer	searchlight
Schiff	ship
Schild	shield
schlagen	to defeat
schleppen	to tow
Schlepper	tractor
Schlitten	sled
schnell	rapid
Schrapnell	shrapnel
Schuss	shot
Schussweite	range
Schutze	gunner

Aggressor	English
Schutzraum	shelter
schwach	weak
Schwerpunkt	strong point
sci	ski
sconfiggere	to defeat
sconfitta	defeat
scontro	encounter, engagement
scoppio	blast
scudo	shield
seccion	section, platoon
secret	secret
secreto	secret
secteur	sector
Section	section
sector	sector
segnale	signal
segno	sign
segno convenzionale	conventional signs
segreto	secret
segundo teniente	second lieutenant
seguridad	security
seguro	safe
selbstandig	independent
sena	signal
senkrecht	vertical
sentinella	sentinel
sentinelle	sentinel
sergent	sergeant
sergente	sergeant
servant	cannoneer
servants de la piece	gun crew
serventi	crew
service de sante	medical corps
servicio	duty
servizio	duty
settore	sector
sezione	section
shrapnel	shrapnel
sicher	safe
Sicherheit	security
sicurezza	security
Sieg	victory
siege	siege
Sieger	victor
siepe	fence
Signal, signal	signal
Signe	sign
signo	sign
signo convencional	conventional signs
Siluro	torpedo
sistema	system
sitiar	besiege
sitio	siege
situacion	situation
situation	situation
situation sin salida	stalemate
situazione	situation
Ski, ski	ski
slitta	sled
Sold	pay
soldado	private, soldier
soldado de primera clase	private first class
Soldat, soldat	private, soldier
soldat de 2eme classe	private
soldat de premiere classe	private first class
soldato	soldier

Aggressor	English
soldato-scelto	private first class
soldato-semplce	private
soldo	pay
sommergibile	submarine
son	sound
sonido	sound
sortie	sortie
sortita	sortie
sotto teninte	second lieutenant
sous-lieutenant	second lieutenant
sous-marin	submarine
soutien	support
spahen	to scout
Spaher	scout
Sperre	barrier, obstacle
sperran	interdict
Sperrfeuer	barrage
spinta	push
Spitze	point
spoletta	fuze
spostamento	traverse
Sprengung	blast
squadriglia	squadron (Avn)
Stab	staff
Stadt	city
Staffel	echelon, squadron (Avn)
stallo	stalemate
standard	standard
stark	strong
Starke	strength
stato maggiore	staff
stato maggiore generale	general staff
stazione radiocampale	radio set
Stein	stone
Stellung	emplacement, position
standardo	standard
still	quiet
storen	harass
Stossgruppe	spearhead
strada	highway, road
Strasse	road
strategia	strategy
Strategie, strategie	strategy
Strom	river
Stunde	hour
subalterno	subordinate
submarino	submarine
suboficial (USA)	master sergeant
subordinato	subordinate
subordonne	subordinate
succes	success
successo	success
sud	south
Suden	south
suono	sound
superpuesto trasparente	overlay
suplemento	supplement
supplemento	supplement
sur	south
surete	security
surtidor	jet
sviluppare	develop
System	system
systeme	system
tacco	overlay
tactica	tactics

Aggressor

tactico
 tactique
 Tag
 Tageslicht
 Taktik
 taktisch
 tala
 taller
 tanque
 tarea
 tattica
 tattico
 Tau
 telefono
 telegrafo
 Telegraph
 telegraphie
 Telephon
 telephone
 telo-cifra
 tempo
 temps
 tenda
 tenente
 tenente colonnello
 teniente
 teniente coronel
 tente
 terra
 terrain
 terre
 terreno
 territoire
 territorio
 testa di sbarco
 Tiefe
 tiempo
 tienda de campana
 tierra
 tiro
 topografia
 topographie
 Torpedo, torpedo
 torpille
 torre
 torreta
 tot
 tourelle
 trabajo
 trabajos
 tracteur
 tractor
 traffico
 trafic
 trafico
 Trager
 train
 trainard
 traineau
 trampa
 tranchee
 tranchee-abri
 tranquilo
 tranquilo
 transmettre
 transmittir

English

tactical
 tactics, tactical
 day
 daylight
 tactics
 tactical
 abatis
 workshop
 tank
 task
 tactics
 tactical
 tow
 telephone
 telegraph
 telegraph
 telegraph
 telephone
 telephone
 panel
 time, weather
 time, weather
 tent
 lieutenant, first lieutenant
 lieutenant colonel
 lieutenant, first lieutenant
 lieutenant colonel
 tent
 land
 terrain
 ground, land
 ground, land, terrain
 territory
 territory
 beachhead
 depth
 time, weather
 tent
 ground, land
 fire
 topography
 topography
 torpedo
 torpedo
 turret
 turret
 dead
 turret
 work
 works
 tractor
 tractor
 traffic
 traffic
 traffic
 carrier
 train
 straggler
 sled
 trap
 trench
 slit-trench
 peaceful
 peaceful
 transmit
 transmit

Aggressor	English
Transport, transport	transport
transportable	transportable
transporte	transport
transportfähig	transportable
trappola	trap
trasmettere	transmit
trasporto	transport
trattice	tractor
travail	work
travaux de terrassement	earthwork
traverse	traverse
Treffen	encounter
Treffler	hit
treibmittel	propellant
tren	train
treno	train
trepied	tripod
treppiede	tripod
trincea	trench
trincerarsi	to dig in
trinchera	trench
trinchera-abrigo	slit-trench
trineo	sled
tripode	tripod
tripulacion	crew
tropas	troops
trou de tirailleur	fox hole
troupe	force
troupes	troops
truppe	troops
Truppen	troops
tube	tube
tubo	tube, barrel
tunel	tunnel
Tunnel, tunnel	tunnel
Turm	turret
Überläufer	deserter
übertragen	transmit
überwinden	to defeat
ufficiale	officer
umfassen	envelop
Umfassung	envelopment
Umfassungsgruppe	encircling force
umgruppieren	reorganize
umzingeln	encircle
unbesetzt	vacant
Ungluck	disaster
unidad	unit
Uniform	uniform
uniforme	uniform
Uniformwinkel	chevron
unite	unit
untauglich	disabled
Unteroffizier	sergeant
Unterseeboot	submarine
unterstellt	subordinate
Unterstützung	support
Urkunde	document
usage	use
uso	use
vacio	vacant
vado	ford
vagone	wagon
vague	wave

vampa	flash
vascello da guerre	warship
vehicule	vehicle
vehiculo	car, vehicle
vehiculo de transporte	carrier
veicolo	vehicle
velocidad	speed
velocita	speed
vencedor	victor
Verband	force, task force
Verband platz	dressing station
Verbindung	liaison
Verfolgung	pursuit
Verhau	entanglement
Verkehr	traffic
Vermessung	survey
Verpflegung	ration
Versager	misfire
Versammlung	rally
Verschlussblock	breechblock
Verstarkung	reinforce
Verteidigungszone	defensive zone
vertical	vertical
verticale	vertical
Verwaltungsbereich	department
vettore	carrier
via	way, road, route
victoire	victory
victoria	victory
village	village
villaggio	village
ville	city
vincitore	victor
vitesse	speed
vittoria	victory
voie feree	railroad
voiture	wagon
vol	flight
volar	fly
volare	fly
voler	fly
volo	flight
Vormarsch	advance
Vorposten	outpost
Vorrat	stores
Vorstoss	push
voto	vacant
vuelo	flight
Wache	watch
Wachposten	sentry post
wachsam	alert
Waffe	arm, weapon
Waffenstreckung	surrender
Waffenwesen	ordnance

Wagen	car, wagon
Wandergeschutz	roving gun
wann	when
Warnung	warning
warten	wait
warum	why
Wasser	water
Weg	way, route
Wehrmacht	armed forces
Welle	wave
Werk	work
Werke	works
Werkstatt	workshop
Westen	west
Wetter	weather
Widerstand	resistance, opposition
wir	we
wirksam	effective
wo	where
zanja	ditch
zapador	pioneer
zappatore	pioneer
Zaun	fence
Zeichen	sign
Zeit	time
Zelt	tent
Zerstörung	demolition
Zeugmeister	quartermaster
Ziel	aim, objective, target
zielen	aiming
Zielspinne	overlay
Zivilist	civilian
Zivilverwaltung	civilian affairs
zona	zone
zona de combate	combat zone
zona de defensa	defensive zone
zona di difensivo	defensive zone
zona di guerra	combat zone
zona di raccolta	rallying point
zona militar	district
zone	zone
zone de defense	defensive zone
zone de l'avant	combat zone -
zubereiten	prepare
Zug	platoon, train
zunden	ignite
Zunder	fuze
zundfertig	primed
Zundkapsel	detonator
Zundschraube	primer
Zundvorrichtung	igniter
zuruckziehen	withdraw
zuteilen	attach