

*A1  
(R)B-47E/char*

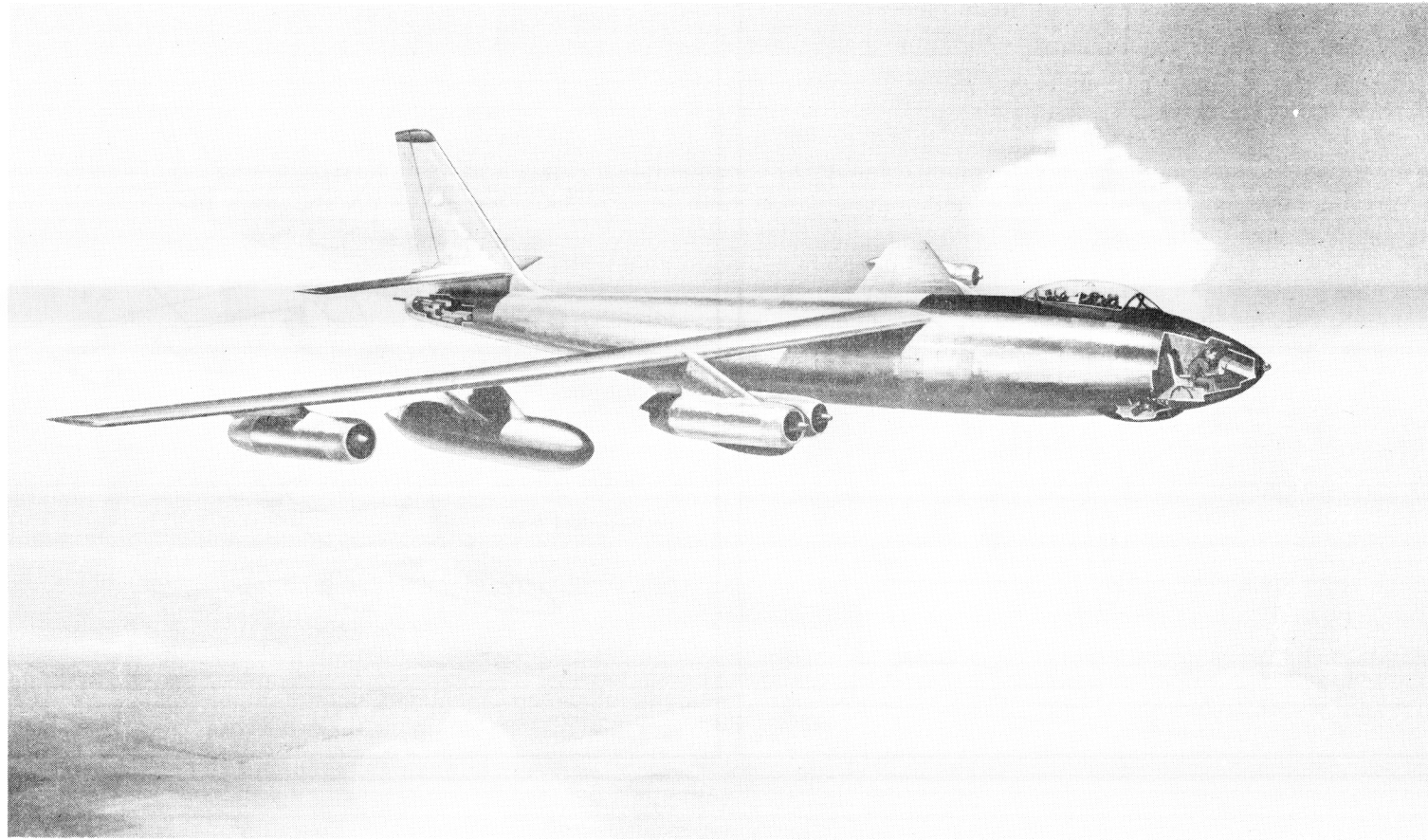

*Standard Aircraft Characteristics*

BY AUTHORITY OF  
THE SECRETARY  
OF THE AIR FORCE

**RB-47E** —  
**STRATOJET**  
**Boeing**

SIX J47-GE-25  
GENERAL ELECTRIC

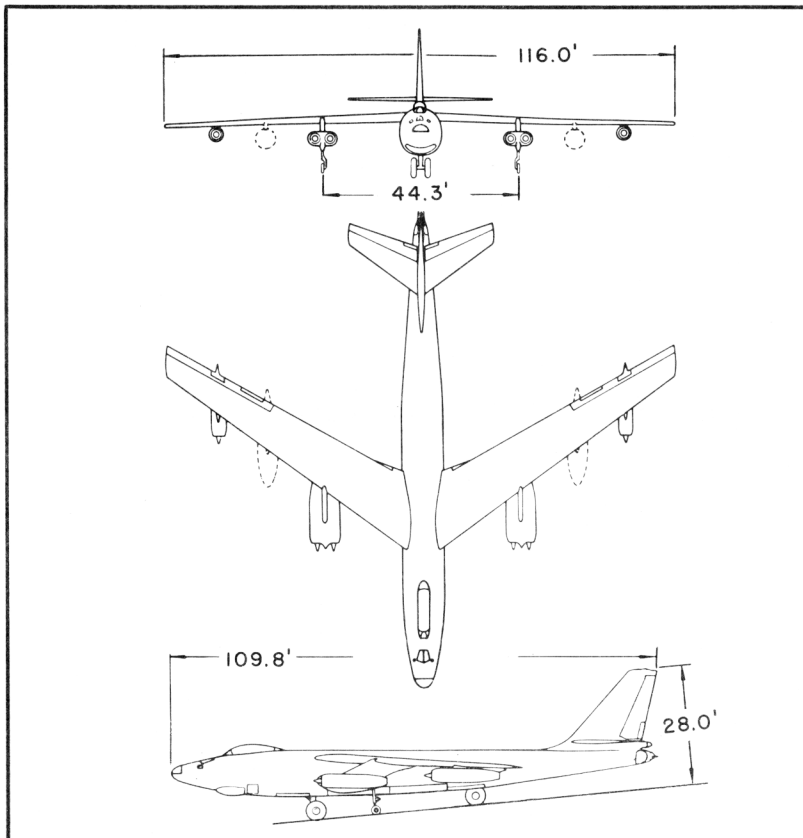

Wing Area . . . . . 1428 sq ft      Wing Section . . . . . Boeing 145  
 Aspect Ratio . . . . . 9.43      M. A. C. . . . . 156"

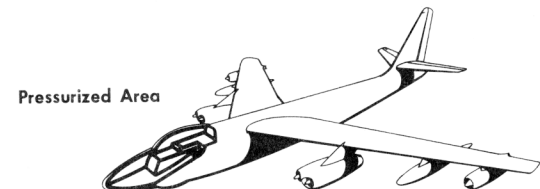
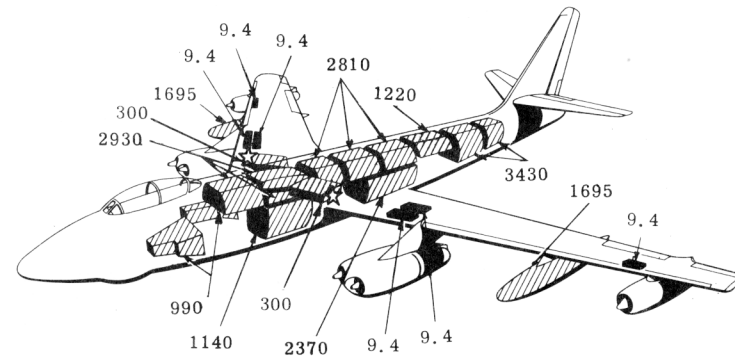

▨ Fuel (Gal)      ☆ Water Alcohol (Gal)      ■ Oil (Gal)

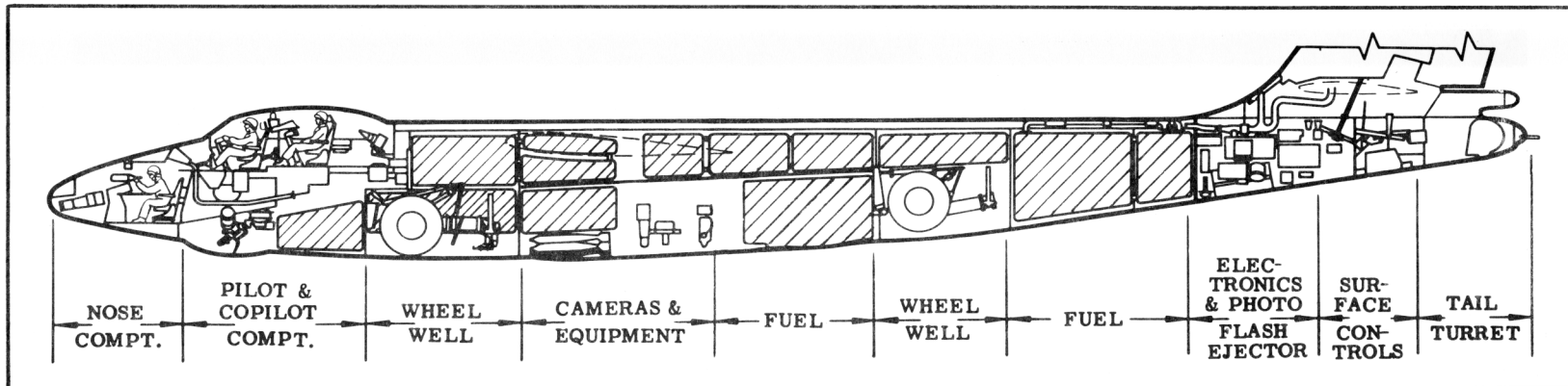

**POWER PLANT**

Nr. & Model . . . . . (6) J47-GE-25  
 Mfr . . . . . General Electric  
 Engine Spec Nr . . . . . E-597  
 Type . . . . . Axial Flow  
 Length . . . . . 148"  
 Diameter . . . . . 39.5"  
 Weight (dry) . . . . . 2707 lb  
 Tail Pipe . . . . . Fixed Area  
 Augmentation . . . . . Water/Alcohol  
 ATO  
 Nr. & Model . . . . . (19) 15KS1000  
 Mfr . . . . . Aerojet  
 Weight (loaded) . . . . . 131 lb ea  
 \*See note h, page 6

**ENGINE RATINGS**

S. L. Static LB - RPM - MIN

Max: \*7200 - 7950 - 5  
 5970 - 7950 - 5  
 Mil: 5670 - 7800 - 30  
 Nor: 5320 - 7630 - Cont

\*wet  
 water flow of 650 lb/min  
 ATO

Thrust (lb) . . . . . 19,000  
 Duration (sec) . . . . . 15

**DIMENSIONS**

Wing  
 Span . . . . . 116.0'  
 Incidence . . . . . 2°45'  
 Dihedral . . . . . 0°  
 Sweepback (LE) . . . . . 36°37'  
 Length . . . . . 109.8'  
 Height . . . . . 28.0'  
 Tread (outrigger) . . . . . 44.3'

*Mission and Description*

Navy Equivalent: None Mfr's Model: 450-158-36  
 The principal mission of the RB-47E is strategic photo-reconnaissance. Alternate missions are day and night mapping, charting and bomb damage assessment.

The normal crew consists of pilot, co-pilot and photo-navigator. Features incorporated for improved crew comfort and efficiency are automatic heating, ventilation, pressurization, NESA glass de-icing for the pilot's windshield, de-frosting of windshield, nose window and other transparent sections by recirculated cabin air, thermal anti-icing for wings and empennage, and hydraulic boost on all control surfaces. Crew ejection seats are provided for in-flight escape. The pilot and co-pilot are ejected upward and the photo-navigator downward.

The water/alcohol injection system utilizes a total tank capacity of 600 gallons which is divided into six individual bladder-type tanks, three each located in the inboard section of the right and left wing.

Solid propellant rockets are installed externally for assist take-off with a droppable rack.

A two-gun tail turret incorporating a radar computer at the co-pilot's station is installed. A rotatable seat allows the co-pilot to face aft while functioning as the A-5 Fire Control System operator.

Other features are single-point and air refueling, an approach chute to increase drag, a drag chute for decreasing landing roll distance and an anti-skid braking device.

*Development*

The RB-47E differs from the RB-47B by the installation of the J47-GE-25 engine and strengthening of landing gear to permit heavier T.O. weight.

**WEIGHTS**

Loading Lb L. F.

Empty . . . . . 81,100 (E)  
 Basic . . . . . 83,190 (E)  
 Design . . . . . 125,000 . . . . . 3.0  
 Combat . . . . . \*130,800  
 Max T.O. . . . . †200,000 . . . . . 2.0  
 Max In-Flight ‡202,000 . . . . . 2.0  
 Max Land . . . . . †180,000

(E) Estimated  
 \* For Basic Mission  
 † Limited by strength  
 ‡ With external tanks

**F U E L**

Location	Nr Tanks	Gal
Fwd, Main*	1	2930
Fwd, Aux	1	990
Center, Main*	1	2810
Fwd, Bomb Bay	1	1140
Aft, Bomb Bay	1	2370
Aft, Main*	1	3430
Wg, Drop	2	3390
ATO Tank	1	1220
*Self-sealing except for 3 cells in forward main tank.		Total 18,280

Grade . . . . . JP-4  
 Specification . . . . . MIL-F-5624A  
 See note (f) page 6  
**OIL**  
 Wing . . . . . 6 (tot) 56.4  
 Grade . . . . . 1005  
 Specification . . . . . MIL-L-6081A  
**WATER/ALCOHOL**  
 Wg, inbd . . . . . 6 . . . . . 600

**B O M B S**

Nr Class (lb)  
 10 Flash Bombs (M-120) . . . . . 154

**G U N S**

Nr Type Size Rds ea Loc.  
 2 . . . . . M24A1 .20mm . . 350 . Fus, Tail

**C A M E R A S**

Nr	Type	Lens
Forward Oblique Station		
1	K-38	24"
Tri-Metrogon Station		
3	KA-3	6"
Vertical Station		
1	K-38	24" or 36"
or		
1	T-11	6"
or		
1	K-37	12"
Split Vertical Station		
2	K-38	24" or 36"
or		
2	K-37	12"

**ELECTRONICS**

VHF Command . . . . . AN/ARC-27  
 Liaison . . . . . AN/ARC-21 & AN/ARC-65  
 Interphone . . . . . AN/AIC-10  
 Radio Compass . . . . . AN/ARN-6  
 Marker Beacon . . . . . AN/ARN-12  
 Glide Path . . . . . AN/ARN-18  
 Fire Control . . . . . A-5  
 Omni Direct Recv'r . . . . . AN/ARN-14  
 Rendezvous Radar . . . . . AN/APN-76  
 or AN/APN-69  
 IFF . . . . . AN/APX-6, 6A, or -25  
 Bomb, Nav. System . . . . . MB-1A  
 Chaff Dispenser . . . . . AN/ALE-1  
 Continued Pg 6 - Note (g)

# Loading and Performance - Typical Mission

C O N D I T I O N S	BASIC MISSION	FERRY RANGE
	I	II
TAKE-OFF WEIGHT (6) (lb)	200,000	200,000
Fuel at 6.5 lb/gal (grade JP-4)	(lb) 103,080	(lb) 103,800
Payload (Chaff)	(lb) 720	None
Wing loading (lb/sq ft)	133.2	133.2
Stall speed (power off) (8) (kn)	157	157
Take-off ground run at SL (1) (ft)	8050	8050
Take-off ground run with ATO (5) (1) (ft)	5650	5650
Take-off to clear 50 ft (1) (ft)	9450	9450
Take-off to clear 50 ft with ATO (5) (1) (ft)	7100	7100
Rate of climb at SL (8) (3) (fpm)	2110	2110
Rate of climb at SL (one eng. out) (8) (2) (fpm)	1680	1680
Time: SL to 20,000 ft (3) (min)	11.6	11.6
Time: SL to 30,000 ft (3) (min)	21.0	21.0
Service ceiling (100 fpm) (8) (3) (ft)	31,500	31,500
Service ceiling (one eng. out) (8) (2) (ft)	28,200	28,200
COMBAT RANGE (4) (n. mi)	3935	3935
COMBAT RADIUS (4) (n. mi)	1915	1915
Average cruise speed (kn)	433	433
Initial cruising altitude (ft)	30,100	30,100
Target speed (3) (kn)	465	465
Target altitude (ft)	39,200	39,200
Final cruising altitude (ft)	43,500	43,500
Total mission time (hr)	8.92	9.15
COMBAT WEIGHT (lb)	130,180	94,020
Combat altitude (ft)	39,200	43,500
Combat speed (2) (kn) (9)	478	487 (9)
Combat climb (2) (fpm)	600	1050
Combat ceiling (500 fpm) (2) (ft)	39,800	46,400
Service ceiling (100 fpm) (3) (ft)	41,100	47,800
Service ceiling (one eng. out) (3) (ft)	38,500	44,700
Max rate of climb at SL (2) (fpm)	4470	6160
Max speed at 20,000 ft (9) (kn)	497 (9)	497 (9)
Basic speed at 35,000 ft (2) (kn)	490 (9)	495 (9)
LANDING WEIGHT (lb)	93,984	94,020
Ground roll at SL (ft)	4600	4600
Ground roll (auxiliary brake) (7) (ft)	2650	2650
Total from 50 ft (ft)	5500	5500
Total from 50 ft (auxiliary brake) (7) (ft)	3550	3550

NOTES

- |   |  |   |  |
|---|--|---|--|
| (1) T. O. power<br>(2) Max power<br>(3) Normal power<br>(4) Detailed descriptions of Radius | and Range missions given on page 6.<br>(5) See note (h), page 6.<br>(6) Includes 4610 lb ATO and 5300 lb water and alcohol | (7) With braking parachute<br>(8) Values quoted are for T. O. weight less ATO, water & alcohol<br>(9) Placard Speed | Performance Basis:<br>(a) Data source: Flight Test<br>(b) Performance is based on powers shown on page 6 |
|---|--|---|--|

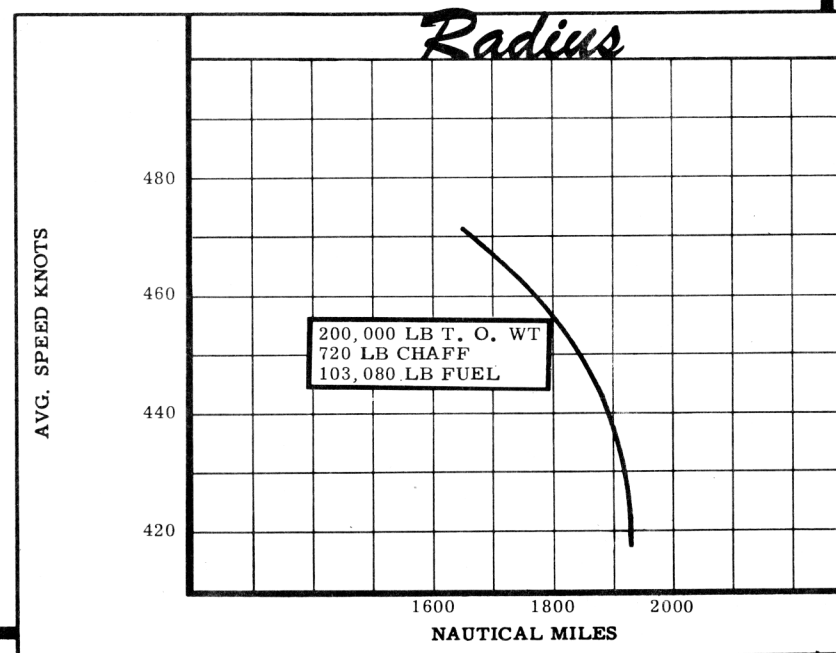
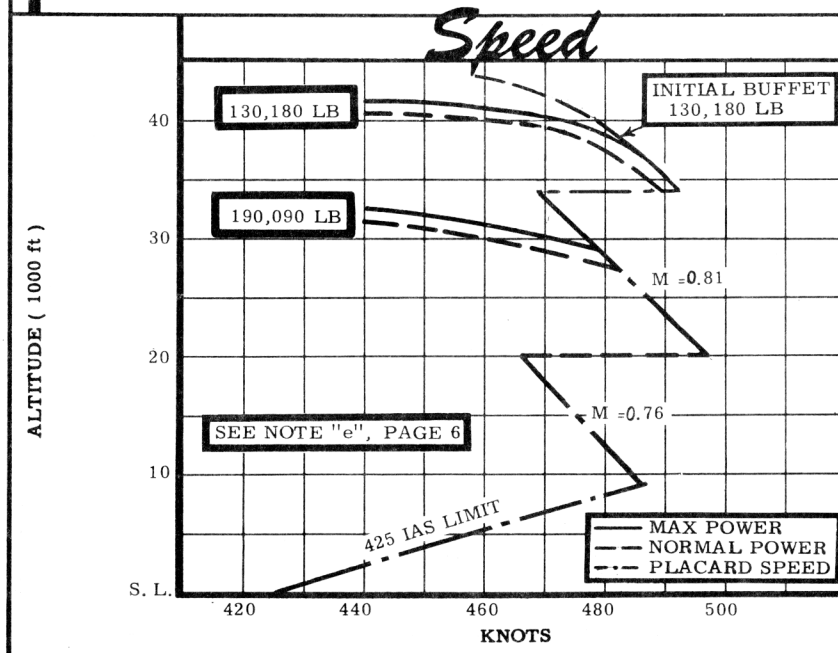
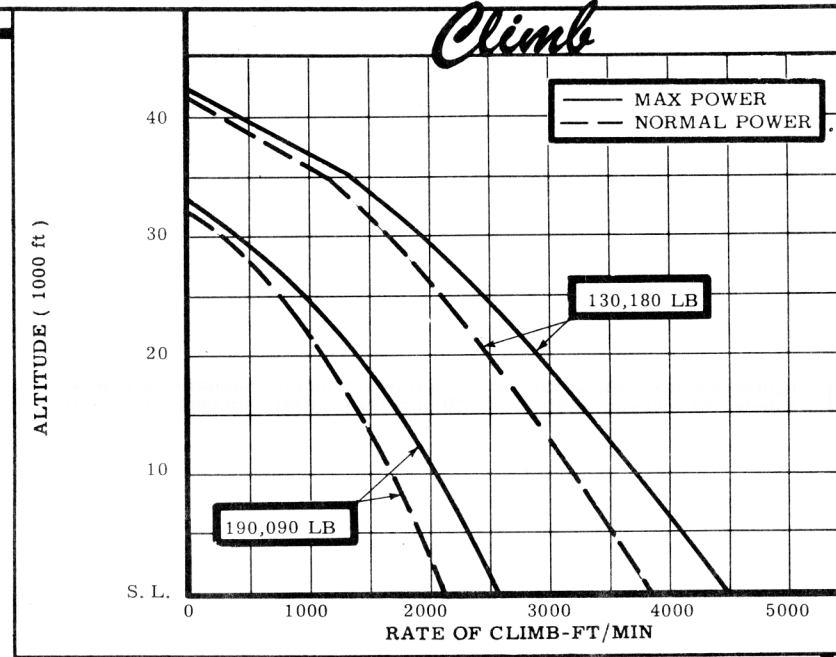
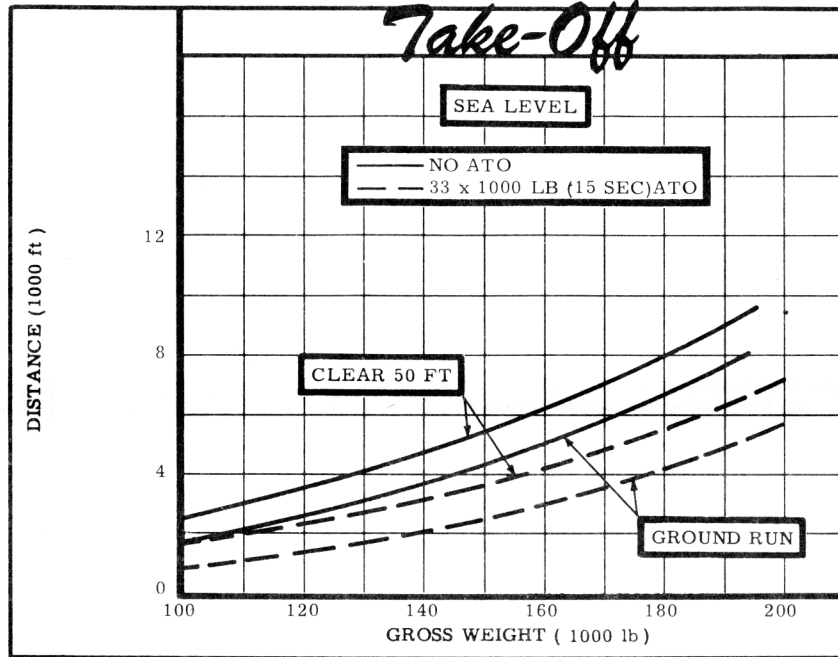

**N O T E S**

FORMULA: RADIUS MISSION I

Take-off and climb on course to optimum cruise altitude at normal power. Cruise out at long range speeds increasing altitude with decreasing airplane weight, external tanks are dropped when empty. Climb so as to reach cruise ceiling 15 minutes from target. Run into target at normal power, drop chaff, conduct 2 minutes evasive action and 8 minutes escape from target at normal power. Cruise back to home base at long range speeds increasing altitude with decreasing airplane weight. Range free allowances include 5 minutes normal power fuel consumption for starting engines and take-off, 2 minutes normal power fuel consumption at combat altitude for evasive action and 20 minutes of maximum endurance (four engine) fuel consumption at sea level plus 5% of initial fuel load for landing reserve.

FORMULA: RANGE MISSION II

Take-off and climb on course to optimum cruise altitude at normal power. Cruise out at long range speeds increasing altitude with decreasing airplane weight until all usable fuel is consumed, external tanks are dropped when empty. Range free allowances include, 5 minutes normal power fuel consumption for starting engines and take-off and 30 minutes of maximum endurance (four engines) fuel consumption at sea level plus 5% of initial fuel load for landing reserve.

GENERAL DATA:

(a) Engine ratings shown on page 3 are engine manufacturer's guaranteed ratings. Power values used for performance calculations are:

(6) J47-GE-25			
S. L. STATIC	LB	RPM	MIN
T. O.	6980	7950	5
Max:	5640	7800	30
Nor:	5270	7630	Cont

(b) For detailed planning refer to Technical Order No. 1B-47(R)E-1 and latest applicable technical orders.

(c) Maximum landing weight 180,000 lb based on approximately 8 ft/sec ultimate rate of descent with 1G wing lift.

(d) All approved weight reduction items incorporated.

(e) Placards shown are for airplanes No. AF 51-5258 thru 52-728, Higher placards applying to the remainder of the airplanes are as shown for B-47E Heavyweight.

(f) Aircraft with Serial No. AF-51-5258 thru AF-52-719 utilize 510 gal ATO tank. Aircraft with Serial No. AF-52-720 and subsequent utilize 1220 gal aft Aux Tank.

(g) Electronics continued from page 3:

- Radio Navigation . . . . . AN/ARN-21
- Warning Radar . . . . . AN/APS-54
- Emergency Keyer . . . . . AN/ARA-26
- Gun Laying Radar . . . . . AN/APG-32
- Radio Altimeter . . . . . SCR-718E
- ECM (2) Various Combinations of AN/ALT-6, AN/ALT-6B, AN/ALT-7 and AN/ALT-8.

(h) The displacement rack must be utilized in carrying the max compliment of (19) 15KS1000.

PERFORMANCE REFERENCE:

Boeing Report D-13194, "B-47 Performance Substantiation. Models B-47B (-23 engines), B-47E and RB-47E", dated 3 June 1953.

REVISION BASIS:

To reflect changes to Electronics Equipment. Data co-ordinated by OCAMA.

Property of the Air Force  
Wright-Patterson Air Force Base  
Ohio 45433  
Museum