

**HIGHEST CLASSIFICATION  
ON THIS ROLL IS:**

**UNCLASSIFIED**

0001

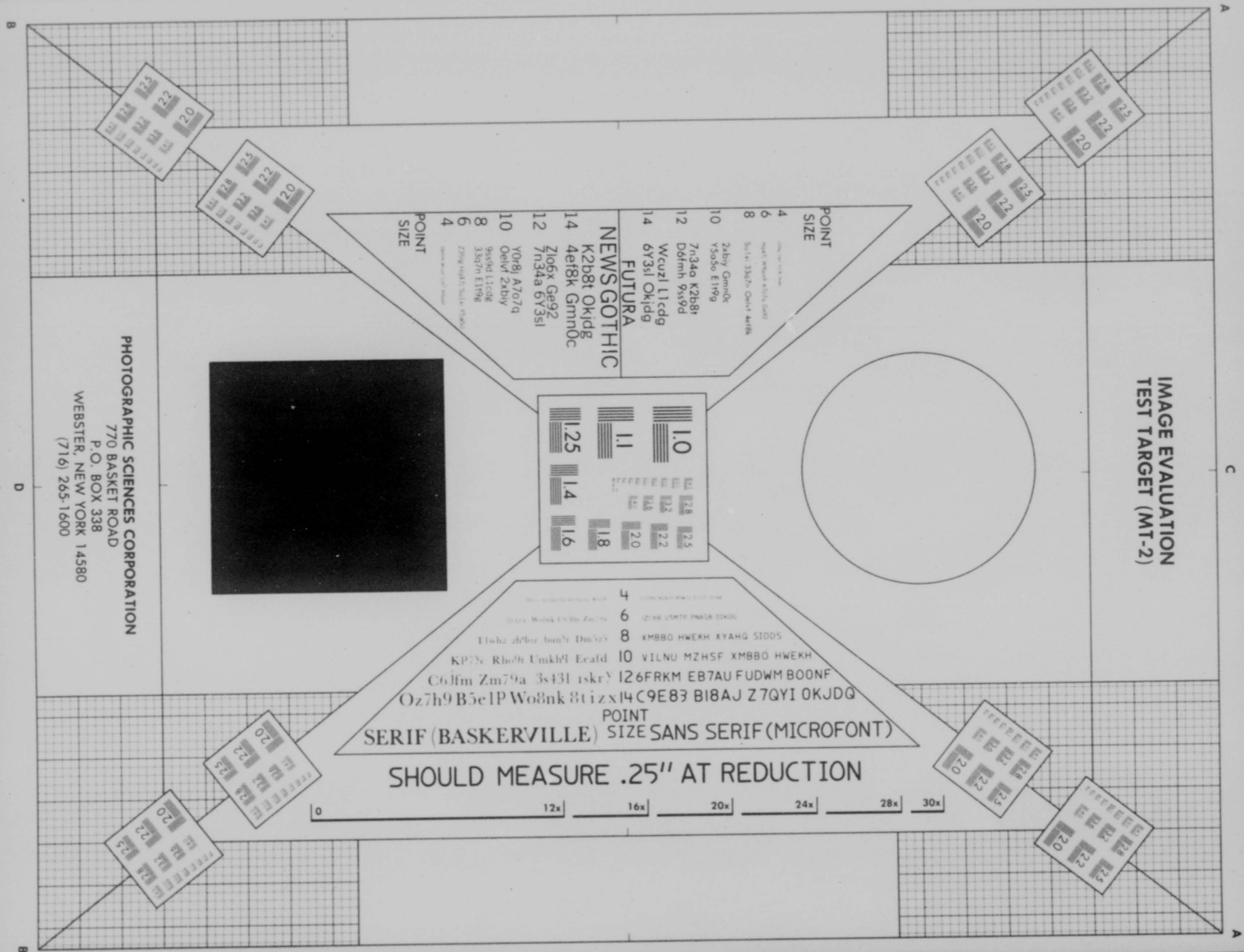



ROLL No. 33602  
DATE FILMED 18 Apr 79  
OPERATOR AC  
LOCATION Maxwell AFB, Ala.  
REDUCTION 26:1

CERTIFICATE  
OF AUTHENTICITY

This microfilm was created from the record copy of unit histories and related historical material of the United States Air Force stored in the Historical Reference Branch of the Albert F. Simpson Historical Research Center at Maxwell AFB, Alabama. This facility is the official repository for these records in accordance with AFR 210-3 and AFM 12-50. This microfilm was created in accordance with the provisions of AFR 12-40 as AU Project AU-1-67. The microfilming was completed under the supervision of the Technical Systems Branch of the Albert F. Simpson Historical Research Center.

*B. H. Hix*  
BILLIE H. HIX  
Chief, Technical Systems Branch  
Albert F. Simpson Historical  
Research Center

0003



0004



0005

OPERATIONS PLANS  
ALLIED EXPEDITIONARY FORCE

INTELLIGENCE DIV.

TIS/00/132/1 — NEPTUNE ARGUS #28-38

506.645-1

44/05/25-

44/07/60

1029150



DECLASSIFIED  
EO 11652

FILE IN  
CLASSIFIED FILES

Box # 28

U.S. Strategic Air Force

A-1 Section

Wing 202

Wing 274

S-462

DECLASSIFIED  
EO 11652

0006



15

SUPREME HEADQUARTERS  
ALLIED EXPEDITIONARY FORCE

:Auth:  
:Initials:

AG 380.01-1 GBI-AGE

DECLASSIFIED  
1998

SUBJECT: Discontinuance of BIGOT Procedure

TO : See Distribution.

1. Reference is made to letter this headquarters, AG 380.01-1 GBI-AGE, subject: "Discontinuance of BIGOT Procedure for Operation SATURN", dated 10 June 1944. Information is furnished that BIGOT procedure has been abolished by the Combined Chiefs of Staff except as to the following current operations:

FAUFART  
FRIGATESS  
AMVIL  
HERCULES  
SATURN

2. The BIGOT procedure no longer applies to any operations not mentioned above, and will NOT be applied to any additional operations.

3. It is considered that Top Secret Control procedure, if properly applied, affords adequate security protection for plans of future operations. A directive on this subject will be issued by this headquarters in the immediate future.

For the Supreme Commander:

[REDACTED]  
[REDACTED]  
[REDACTED] 95716

E. C. BOYD  
E. C. BOYD  
Colonel, AGC  
Adjutant General

## DISTRIBUTION:

Copy No.

- 1 - GPD, War Department General Staff, Washington 25, D.C.
- 2 - Director of Military Operations, War Office, London
- 3 - Secretary of the Admiralty, London
- 4 - Secretary of the Air Ministry, London
- 5 - Combined Chiefs of Staff, Washington 25, D.C.
- 6 - Chief of Naval Operations, Navy Department, Washington, D.C.
- 7 - Supreme Allied Commander, Mediterranean Theater.

TOP SECRET

1029150

0007

TOP SECRET

Ltr: SHAPE, AG 300.01-1 GRI-AGM  
dtd 2 July 1944 (con't)

DISTRIBUTION: (con't)

Copy No:  
- CO, DIVUSA  
9 - C-in-C, 21 Army Gp  
10 - CO, TUSAC  
11 - Air C-in-C, AFAP  
12 - ANMCP  
13 - CG-DAVID  
14 - TUSA  
15 - CG, USSDIY  
16 - ANMCP, SHAPE  
17 - AFAP, SHAPE  
18 - SCS  
19 - G-1  
20 & 21 - G-2  
22 - G-3  
23 - G-4  
24 - G-5  
25 - ADD  
26 - FRD  
27 - IND  
28 - CSO  
29 - CE  
30 - Chief Medical Officer  
31 - SMC  
32 - Pol Officers  
33 & 34 - AG Records



TOP SECRET

0008



NIS/CO/152/1.

~~SECRET~~  
BIGOTSEPTIME HEADQUARTERS  
MILITARY INTELLIGENCE FORCE  
G-2 (LITTELLFIELD) DIVISION

FOR REPORT

101  
FORM NO. 1

25 May 44.

NEPTUNE ARGUS NO: 28

With this Report:

Appendix A - Artillery

Appendix B - Obstacles

Amendment to NEPTUNE ARGUS No. 27 dated 24 May 44.

Para. 6. For "SL" read "Sheet" in each case

Underwater obstacles in the SEPTIME area.

1. Vertical and oblique cover of 24 May 44 shows that the erection of stakes on the East side of the COTENTIN has been continued, as was to be expected. It is evident that the obstacles south of the DUNES DE VAREVILLE are being completely re-arranged. The removal of element 'C', reported in last night's NEPTUNE ARGUS, is confirmed. The oblique cover shows considerable silting up of obstacles, many of which are standing in pools of water at low tide. Drawings showing the latest arrangements are attached.

Anti-air-landing obstacles.

2. The anti-air-landing obstacles obstructing open ground in the vicinity of CAREN, hitherto thought to be posts, are reported by a new source to be lengths of steel rails. They are also stated to be joined together with barbed wire.

Railway tunnel near HERJOUMap Ref: G.S.G.S. 4290 7/5 9335

3. A fair source reports the presence of an armoured train in the HERJOU tunnel on the railway line PIERES - PALAIS.

Comment:

A previous source has reported ammunition storage in this tunnel (NEPTUNE ARGUS No. 20, para 2). As reported in NEPTUNE ARGUS No. 21, para 1, it has been known for some time that the Germans have shown an interest in this tunnel and normal traffic has been suspended on sections of the line. No ammunition movements have yet been noted to the HERJOU area and it is now likely that the tunnel will be used for another purpose. There is NO confirmation, however, of the armoured train report.

Proben battery at TAILLEVILLEMap Ref: G.S.G.S. 4347 37/18 G.S.

4. Air-cover of 24 May shows new developments at the battery site at 992018. This site, it will be recalled, was first thought to contain Rocket Projectors and subsequently accepted as a 6-gun heavy Flak position. Now four new emplacements have been constructed to the rear of the others.

UNCLASSIFIED

DATE: 188 8407 27 JUN 44 952/18

REASON: 188 8407 27 JUN 44 952/18

/Each .....

0009

BIGOT

Each contains a large rectangular (possibly cylindrical) object, which it is not possible to identify on present cover. Two of the original six emplacements are now empty. Since the latest addition to the position, its role appears even more problematic than before.

Air Cover: 16/259, 24 May 1944, 3099 and 4092.

Underwater obstacles: Concrete Tetrahedra

5. A new source supplies the following information on concrete hedgehogs, which are being laid on beaches near the ADOR estuary. He states that at the end of March, manufacture of these obstacles was to be intensified fourfold and that for this purpose the Organisation TODT was lending personnel to the BAYNNE firm concerned. Each obstacle consists of six elements, assembled and bound together with steel bands. The elements are 2.2 metres long and 15 cm. x 15 cm. in section; they are made of concrete reinforced with 12 mm. steel rods. See sketch.

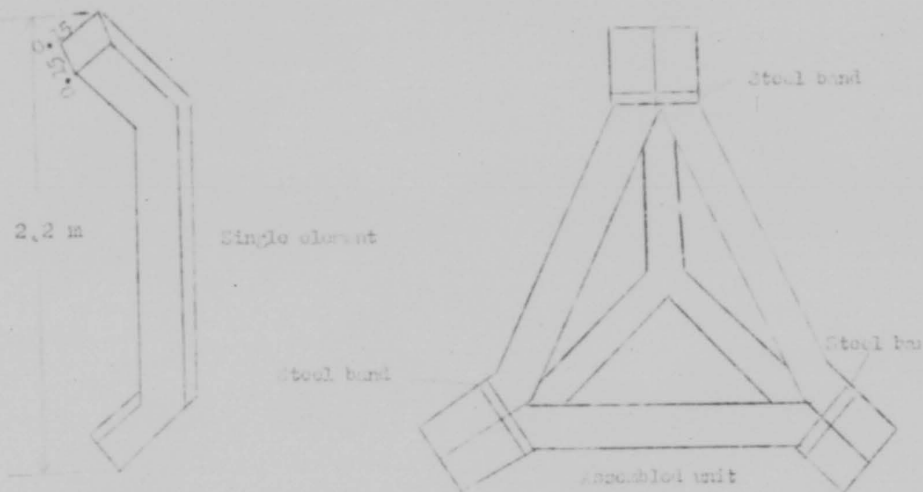

Comment:

There is no indication of the number to be manufactured in April and later on; this firm had up to the end of March made nearly 3,000 obstacles. These of course were for use in the ADOR sector only.

Major-General,  
A.C. of S.,  
G-9.

TOP SECRET  
BIGOT

0010

TOP SECRET

APPENDIX 'A' TO REPORT ARMS NO. 28  
Dated 23 May 1944.

ARMY ARTILLERY IN THE NEPTUNE AREA

I. B.L.S. DAMAGE

1. LE HAVRE, LE GRAND CLOS BATTERY Reference MAP: G.S.G.S. 4250/794 & 883  
 467307

Recent cover shows the following situation at this superheavy battery after the raid of 9 May:

No. 1 Casemate: Barrel again in position. Some debris has been cleared away. The breach in the circular wall of the casemate has NOT been repaired. A deep excavation has been cut in the Northern wing of the casemate where a probable hit was reported. It is extremely likely that the gun turret itself sustained a direct hit, with a hole apparent in the armour.

No. 2 Casemate: Little activity. No further work in progress on the gun turret under the gentry crane.

No. 3 Casemate: Site appears abandoned. No change since the raid of 10 April.

Air Cover: Sortie 400/123 Photo No:  
 of 19 May 1944

Comment:

From the state of construction it appears that all work on this site may have been abandoned, except on No. 1 Casemate, which may itself be unserviceable.

2. OURSSEL FARM BATTERY

Reference MAP: G.S.G.S. 4250/881/  
 565452

This four gun radius howitzer battery was bombed on 20 May and 22 May 63 x 2000 lb. G.A. and 128 x 1000 lb. G.A. bombs being dropped. A considerable number of craters are visible within 100 yards of the gun positions. All four emplacements are occupied, with no serious damage visible except possibly to No. 1 emplacement. However, the position appears to be greatly disorganized, with numerous hits on roads, cable lines, command post, shelters and communication trenches.

Air Cover: Sortie US 107/416 Photo No: 005002-4  
 of 22 May 1944

CONFIDENTIAL

95P10

/11 OTHER REPORTS

TOP SECRET  
 BIGOT

## BIGOT

II. CONCRETE

1. WAGVILLE Reference Map: GSGS 4250/611/205218

This four gun light battery now has a light anti-aircraft gun on the roof of Nos. 2, 3, and 4 emplacements.

Air Cover: Sortie 16/244 Photo nos. 3061  
of 22 May 1944

2. LE WALS, LA GORCEL Reference Map: GSGS 4250/71 304/164314  
Barracks

Number 1 emplacement appears complete and is occupied by a gun, the barrel of which projects 20 feet beyond the emplace.

Air Cover: Sortie 400/123 Photo nos. 3067-8  
of 19 May 1944.

Remarks:

Guns of this battery believed to be 170 mm.

3. LA SALLE EN BOIS Reference Map: GSGS 4250/714/883/45830

Very little progress is seen in the emplacing of this medium mortar battery. Two emplacements are still in the excavation stage, work on the other two has not advanced appreciably since 22 April.

Air Cover: Sortie 400/123 Photo nos. 4061, 4069  
of 19 May 1944

4. CHATELAIN-BATTELI Reference Map: GSGS 4250/715/818853

The camouflage has been removed from number 1 emplacement, which appears to be unoccupied.

Air Cover: Sortie 140/157 Photo nos. 3164-5  
of 22 May 1944

5. CHATELAIN-BATTELI Reference Map: GSGS 4250/502/917320

This concrete shelter annotated on defenses overprints as "7 concrete artillery CP" is now seen to have a searchlight in a square emplacement on its roof.

Air Cover: Sortie 16/244 Photo nos. 4069 (Vertical)  
of 22 May 1944. 0001 (Oblique)  
and 430/162-172  
May 1944

6. NESTLE Reference Map: GSGS 4250/62304/355105

Reference paragraph 2, Appendix 'A', NESTLE JRGUS 24 May 1944:

It is regretted that the last three figures of the map reference were omitted.

// . . . . .

TOP SECRET  
BIGOT

0 0 1 2

BIGOT

- 3 -

7. SOLINGVILN (SOUTHWEST OF MMS) Reference Map: GAGE 4250/7E5/333820

Four circular emplacements 17 foot in diameter are seen here. Numbers 1 and 2 appear to be occupied by unidentified objects, and number 3 is possibly occupied. Number 4 is unoccupied.

Slight track activity is visible.

Air Cover: Sortie 16/249 E. S. No. 3108-9  
of 25 May 1944

Comment:

It is NOT clear that this is a genuine position. It would presumably contain light field guns.

G-2 (INTELLIGENCE) DIVISION  
SECRET  
25 May 1944.

TOP SECRET  
BIGOT

0013

BIGOT

TOP SECRET

APPENDIX 'E' TO NEPTUNE APOUS NO. 26  
Dated 22 May 1944

Obstacles in the NEPTUNE Area

(a) Road-blocks

1. BRITANNY and the COTENTIN

Obstacles on roads leading to all fairly important localities in BRITANNY and the COTENTIN are reported to be found in the following order.

- (1) The roadway is prepared for chattering. At the moment the mine-chambers are covered with concrete lids.
- (2) A rail obstacle. The rails are NOT in position in normal circumstances and the concrete sockets have wooden or concrete covers.
- (3) A wall road-block with the usual gap for traffic in the centre of the road. In the gap are sockets for a rail obstacle. This type of obstacle is said to have generally replaced the "Iron gate obstacles" (Elements 'C').

Comment:

This report is accepted, though NOT confirmed by air-photos, on which, clearly, only the wall road-block could ordinarily be seen.

2. VERNEUIL

Reference Map: G.S.G.S. 4250/89/2.

There are road blocks across the main roads in squares 9938, 0039 and at 007379.

Air Cover: None

Comment:

It is NOT possible to pinpoint the first two road blocks.

3. EVREUX

Reference Map: G.S.G.S. 4250/99/3.

Date of Information: March 1944.

There is an anti-tank wall at 221670. It is 1 metre 50 high, 20 metres wide and 50 centimetres thick, and it has a loophole for a machine-gun.

Air Cover: None

/4. DOUVRES

CONFIDENTIAL

REMARKS  
 DATE: 17th MARCH 1944  
 95A/6

TOP SECRET  
 BIGOT

0 0 1 4

BIGOT

- 2 -

## 4. DOUVRES LA DELIVRANCE

Reference Map: G.S.G.S. 4347, Sheet  
40/18 SE/008799

There is a road block on R. 16 at 008799, just west of its junction with a minor road, South of the village.

Air Cover: 430/147Photo No: 0001Date of Information: 19 May 1944

## 5. MONTEBOURG

Reference Map: G.S.G.S. 4347, Sheet  
31/20 SE

At 312060, a concrete anti-tank wall blocks the road from QUINVILLE just North of MONTEBOURG.

Air Cover: Sortie 106G/434Photo No: 3371Date of Information: 19 May 1944

## 6. FRANCEVILLE PLAGE - LE GRAND HOMME

Reference Map: G.S.G.S. 4347, Sheet  
40/16 NE

Temporary roadblocks are seen at the following points on the main coastal road and on sidestreets leading off it:-  
15857893, 16017899, 16227907, 16987917, 17217919, 17427915, 17607908, 178479X  
18037905 and 19057946.

Air Cover: Sortie US. 34/428Date of Information: 20 May 1944

## (b) Ditches.

## 1. CHERBOURG

Reference Map: G.S.G.S. 4347, Sheet  
31/22 SE/15235

The anti-tank ditch running South from the quayside has now been extended southward to cut the boulevard Maritime at 155235.

Air Cover: Sortie 106G/434Date of Information: 19 May 1944

## 2. STE CROIX HAGUE

Reference Map: G.S.G.S. 4347, Sheet  
23/22, Composite

The anti-tank ditch previously reported, running South from the coast at GRUCHY has been further extended South of STE CROIX HAGUE, from 029223 to 031224 and from 024229 to 023231.

Air Cover: Sortie 106G/440Photo No: 4143-5Date of Information: 20 May 1944

## 3. ANGERS

Reference Map: G.S.G.S. 2738/14

A ditch, probably anti-tank, about 15 feet wide runs from the R. LOIRE at approximately 895729 Northward for some 750 yards.

Air Cover: Sortie 140/94 of  
7/5/44Photo No. 4171/2Date of Information: 7/5/44TOP SECRET  
BIGOT

/4. 5

0015



BIGOT

- 3 -

## 4. ST. LAURENT SUR MER

Reference Map: G.S.G.S. 4347, Sheet  
24/18 SE

The anti-tank ditch running behind the strongpoint and parallel to the coast has been further extended in a northerly direction, from 67449012 to 67509017.

Air Cover: Sortie 140/157Photo No: 4181-2Date of Information: 22 May 1944

## 5. VAR SUR MER

Reference Map: G.S.G.S. 4347, Sheet  
37/18 SE

Work continues on the anti-tank ditch previously reported between 921866 and 913866. A further new stretch of ditch is now seen to the west of this, running from 91253655 - 91118647.

Air Cover: Sortie 140/157Date of Information: 22 May 1944Reference Map: G.S.G.S. 4347, Sheet  
37/18 SE

## 6. ANSELLES

Construction continues on the anti-tank ditch parallel to the main road from 87050638 via 87543620 to 87688640. There is a short gap at 87403625.

Air Cover: Sortie 140/57Date of Information: 22 May 1944(c) Underwater Obstacles.

## 1. ROCHES DU RIT

Reference Map: G.S.G.S. 4347/28/18 NE

Underwater obstacles previously reported between 960971 and 979974 are now seen to be ramps.

Air Cover: Sortie US 31/49  
of 24 May 44Photo No: 0104

## 2. BARFLEUR

Reference Map: G.S.G.S. 4347/31/22 SE

7 unidentified obstacles are seen at 39972502.

Air Cover: Sortie 106/455  
of 22 May 44Photo No: 3002-3

## 3. MONTAIGNE-SUR-MER

Reference Map: G.S.G.S. 4347/31/14 NE

Large obstacles of an unidentified type are seen between 145503 and 147512.

Air Cover: Sortie 106 4/386  
of 11 May 44Photo No: 3240-14. Amendment to tracing issued with  
NEPTUNE ARGUS No. 27

Reference Map: G.S.G.S. 4490/74

The three rows of obstacles shown on the tracing as "T stakes" are now confirmed as stakes.

Air Cover: Sortie 2/83  
of 24 May 44

G-2 (INTELLIGENCE) DIVISION

SHAEP.  
25 May 1944.TOP SECRET  
BIGOT

0016

UNITED STATES OF AMERICA  
NATIONAL BUREAU OF SURVEYING  
WASHINGTON, D. C. 20540

UNITED STATES OF AMERICA  
NATIONAL BUREAU OF SURVEYING  
WASHINGTON, D. C. 20540

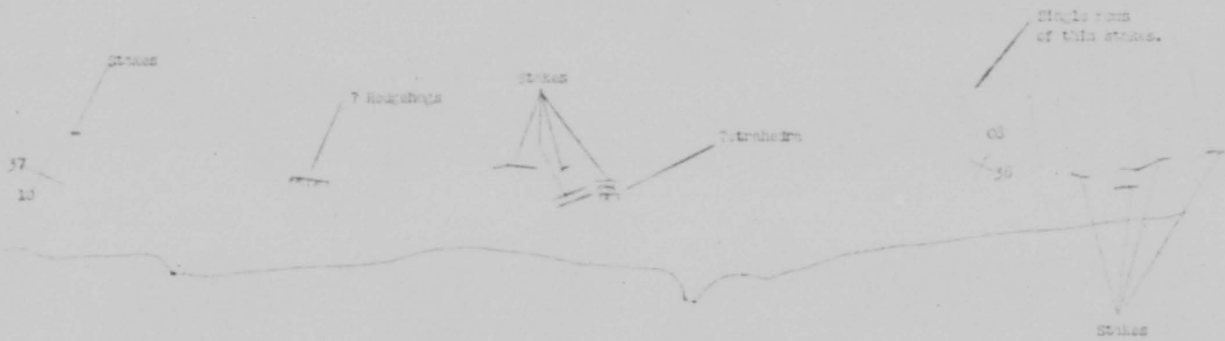

SECTION

Scale : 1:12500  
Sheet No. 71

As shown on additions from  
Sheet 1, 2, by L.

TOP SECRET

0017

BIGOT

Issued with Appendix 'E' to NETTING GUIDE NO. 20  
Dated 21 May 1944.

TOP SECRET.

FORWARDING MAP - Sheet 1

G.S.C.S. 4490 - Sheet No. 72  
Scale: 1:12500

Additions and amendments  
only shown North of  
this point.  
Bartle 16/262.  
24 May 44.

Oblique Bartle  
2/03, 24 May 44.  
gives accurate identification  
of all types of obstacle  
shown South of this point; the  
trace for this area supersedes all  
previous traces.

O-2 (INTELLIGENCE) DIVISION  
STAFF.  
25 May 1944.

TOP SECRET  
BIGOT

0018

# BIGOT

Issued with Appendix 'A' to LITTONK AGENTS NO. 20  
 dated 25 May 1944.

TOP  
 SECRET

EXHIBIT 101.018 - Sheet 2

G.S.C.S. 4490 - Sheet No. 72  
 Scale: 1:12500

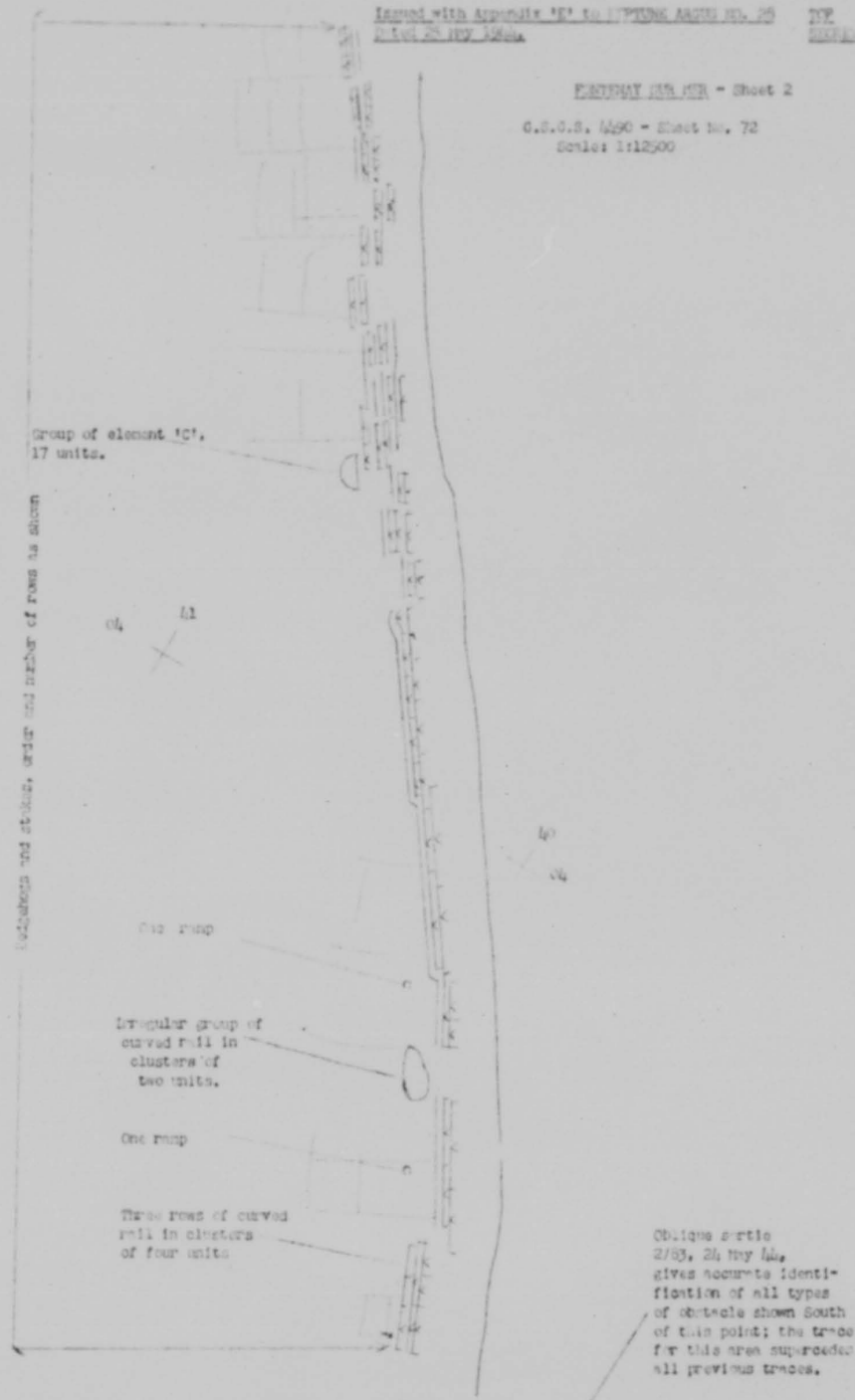

Group of element 101,  
 17 units.

Locations and status, order and number of rows as shown

04 41

One ramp

Irregular group of  
 curved rail in  
 clusters of  
 two units.

One ramp

Three rows of curved  
 rail in clusters  
 of four units.

Oblique article  
 2/23, 24 May 44,  
 gives accurate identi-  
 fication of all types  
 of obstacle shown South  
 of this point; the trace  
 for this area superseded  
 all previous traces.

G-2 (INTELLIGENCE) DIVISION  
 25 May 1944.

TOP SECRET  
 BIGOT

0019

# BIGOT

Report with Appendix 12110 WATERWAYS NO. 20  
 Dated 25 May 1944

TOP SECRET

NOTE:  
 Unique Bertie D/03 on May 14  
 makes it possible to give exact  
 identification of under-water  
 obstacles on this trace.

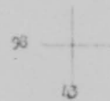
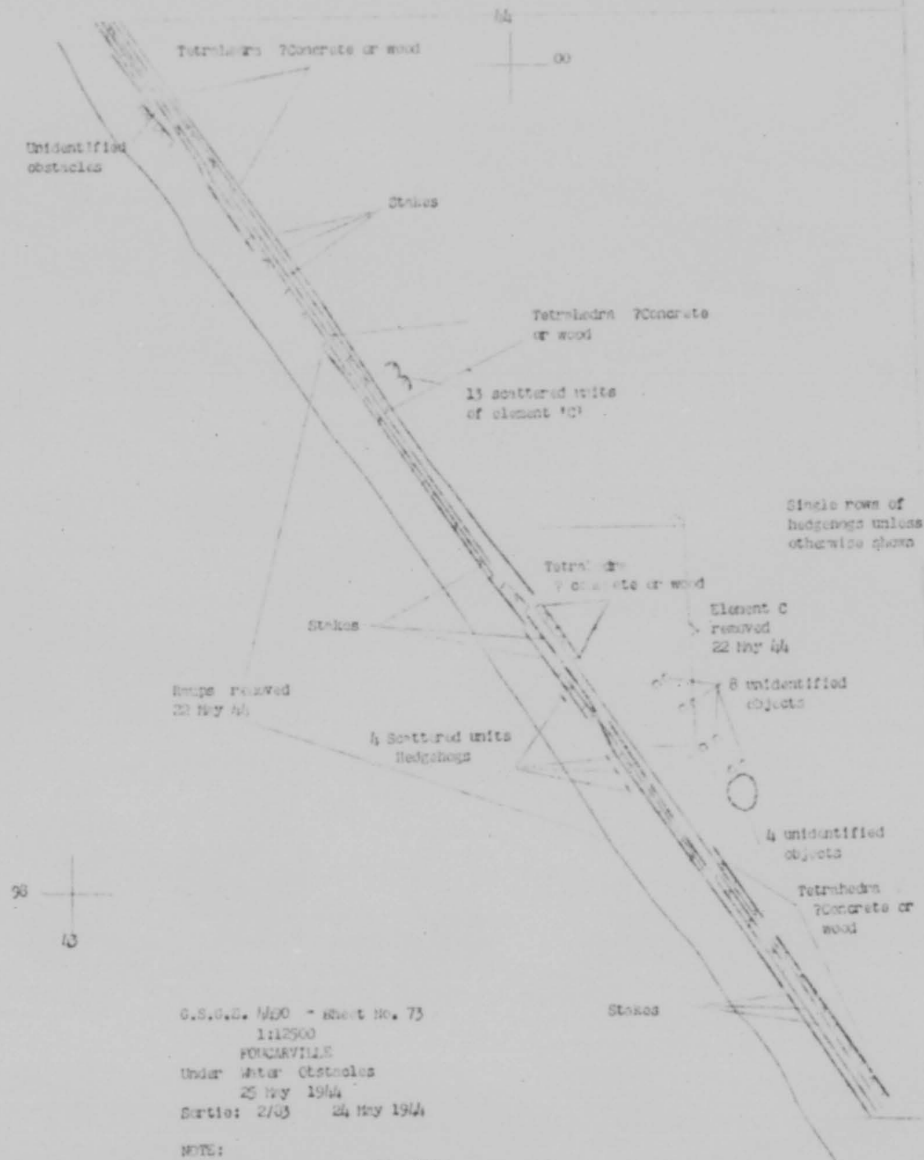

U.S.G.S. 1400 - sheet No. 75  
 1112500  
 FONGARVILLE  
 Under Water Obstacles  
 25 May 1944  
 Bertie: 2/03 24 May 1944

NOTE:  
 This trace supersedes all others.

0-2 (INTELLIGENCE) DIVISION  
 SHALP  
 25 May 1944

TOP SECRET  
 BIGOT

0020

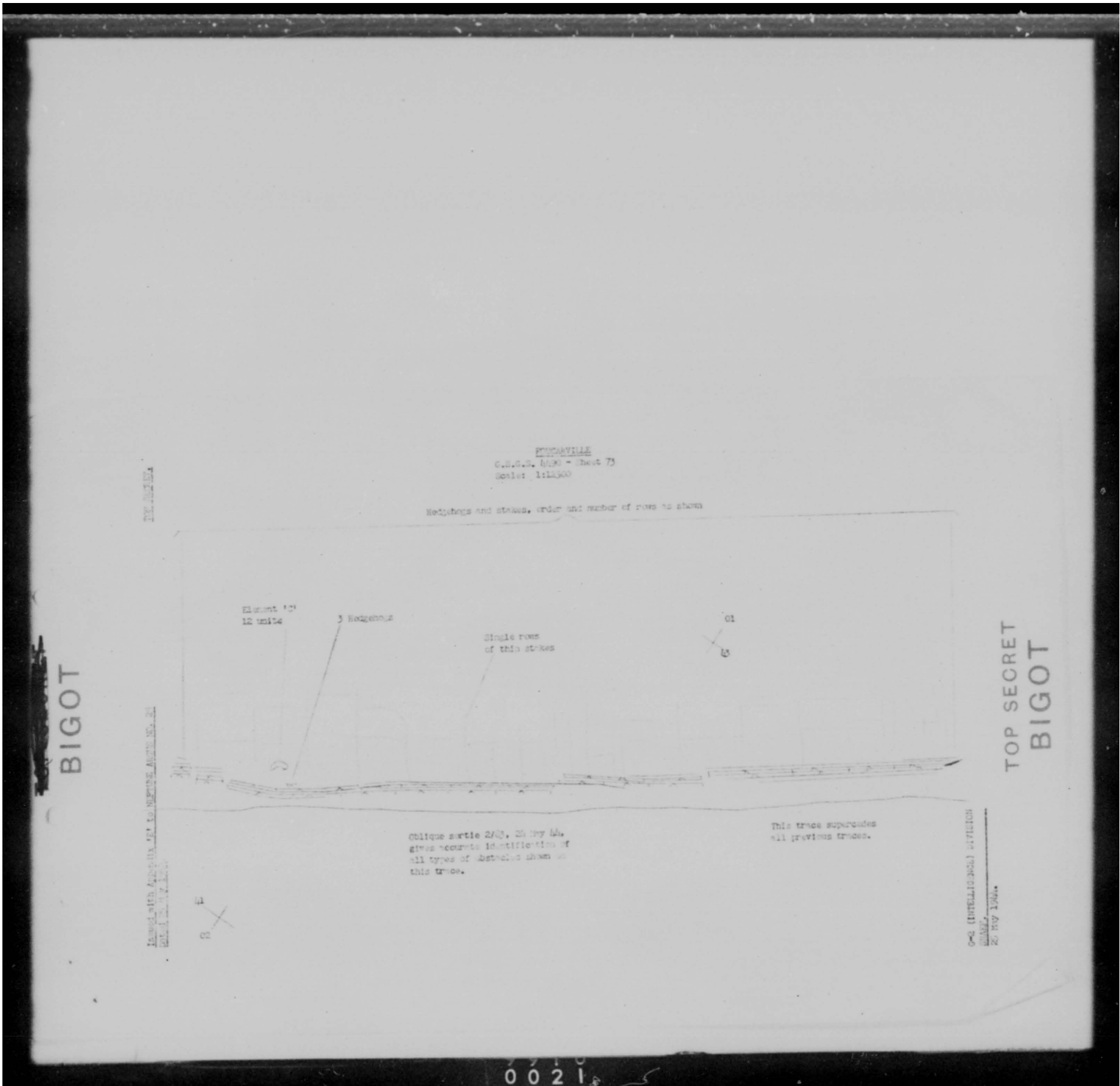

# BIGOT

Issued with Appendix 'E' to NEPTUNE ARGUS NO. 28  
Dated 25 May 1944.

TOP SECRET.

GSIS 4430, Sheet 74, ANDOVILLE-LA-BERT - 1:12,500

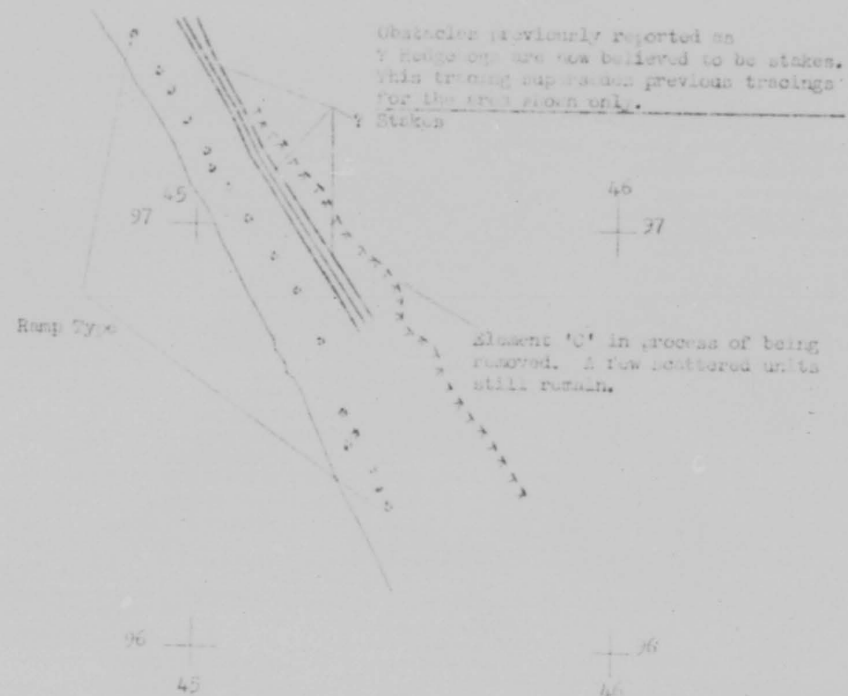

G-2 (INTELLIGENCE) DIVISION  
SPASF.  
25 May 1944.

TOP SECRET  
BIGOT

0 0 2 2



~~TOP SECRET~~  
BIGOT

TOP SECRET

Figure 1010 Appendix 201 to AFM 71-101, No. 2, dated 24 Nov 1954

Revised: AFM 71-101, No. 2, dated 1/18/55

Addition and amendments to the tracing issued  
in the AFM 71-101, No. 2

Revised: AFM 71-101, No. 2

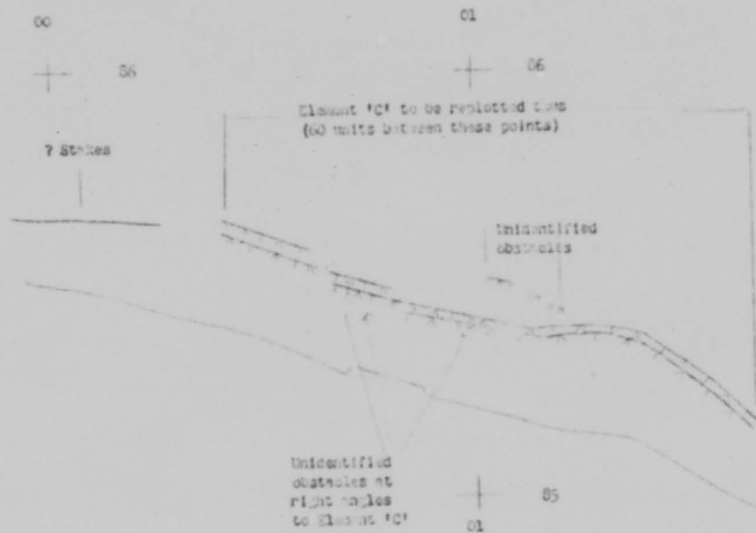

2-2 Intelligence Division, SHAPE  
25 Nov. 1954

TOP SECRET  
BIGOT

0023

## BIGOT

REF/00/132/1

REF 132/1

SUPREME HEADQUARTERS,  
ALLIED EXPEDITIONARY FORCE,  
G-2 (INTELLIGENCE) DIVISION.

Copy No.

26 May 1944

NEPTUNE ARGUS NO: 29

With this Report:

- Appendix 'A' - Artillery
- Appendix 'C' - Minor Defences
- Appendix 'D' - Naval Defences
- Appendix 'E' - Obstacles
- Appendix 'G' - Ammunition Dumps
- Appendix 'I' - V/T Installations
- Appendix 'K' - Stores Dumps

1. CAS

Date of Information: December 1943

6 trains of petrol (182 tank-wagons) were despatched from STRASBOURG to CAS via METZ on 15 December 1943.

Comment:

This is part of a reliable rail traffic report. The quantity stated is equivalent to at least 2700 tons of petrol. Such a consignment, on one single day, would be exceptional for any destination in FRANCE. At CAS it is particularly remarkable, as it was difficult already to account for the NOT negligible, though NOT very important, traffic reported hitherto (See Appendix 'H' to NEPTUNE ARGUS No. 6, page 2, paragraph b). No armoured troops were in the CAS district in mid-December, and no important depot is known at CAS; the GERMAN policy respecting coastal airfields makes it unlikely that the fuel was for CARPIQUET. Other possibilities are:-

- (a) storage in an unknown (underground?) depot,
- (b) refuelling of supply boats on the OUESTREHAM Canal?

(?) "Mushroom-type" Underwater Obstacles

3. A heavy source, reporting from the MEDITERRANEAN in April 1944, mentions the use of a "mushroom-type" underwater obstacle. The attached sketch gives some indication of the appearance of the

/obstacle.....

CONFIDENTIAL

95P/6

TOP SECRET  
BIGOT

0024

BIGOT

- 2 -

obstacle; but NO measurements are given. The obstacles are said to be of steel and to be joined together by barbed wire.

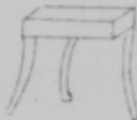

Comment:

It is possible that this obstacle is a tetrahedra and that the source's impression of the size of its head is exaggerated.

Constructional Activity East of PONT AUDEMER

3. An excellent source reports three constructional sites for a secret weapon at the following places: reference map GSGS 4250, Sheet 8F/2:-

VALLETOT	820875
LE PETIT BOISNEY	850860
LA PREE	910990

This is confirmed in all three cases by air photographs, although bombing of the VALLETOT site has to some extent obscured the nature of the work. (Sortie 4/22 or 27 April 1944).

Comment:

See NEPTUNE ARGUS No.14, paragraph 4, and previous references to activity in this area. Constructional activity reported here appears to resolve itself into two classes:-

(a) Construction of infantry field defences at the approaches to PONT AUDEMER, LOUVIERS and probably also ELBEUF.

(b) Construction of secret weapon sites (Vergeltungswaffe) on the high ground between PONT AUDEMER and LOUVIERS. The three sites mentioned above are the only ones known in the area.

Activity on LES ILES, S. MARCOUF

4. Reference Maps: G.S.G.S. 4347, Sheet  
34/20 SW, 478057.

An excellent vertical sortie of 24 May 1944 shows the following activity within the fort on the ILE du LARGE:-

(i) The small round tower opposite the lighthouse in the courtyard of the large drum-tower of the fort has been demolished. Debris can be seen on the floor of the courtyard at the place where this turret formerly stood. Comparative cover shows that this demolition has taken place since 30 April 1944.

(ii) Fresh spoil is seen on the North West flank of the long barbette that leads SW from the drum-tower to the outer ramparts. A shallow bay, some 20 feet wide, appears to

/have.....

TOP SECRET  
BIGOT

7 7 1 4  
0 0 2 5

## BIGOT

- 3 -

have been dug at this point. It had not been started on 26 April 1944.

(iii) There may also be slight activity at the North East corner of the small harbour. A gap in the sidewalk and some adjacent spoil suggest that the outer wall of the fort may have been breached at this point.

No activity is seen on the ILE de TERRE.  
(Sortie 110/174 of 24 May 1944, photo nos. 3128-30, 4114-5).

Comment:

The reason for the demolition of the tower is unknown. The excavation work is probably preparatory to the building of defence works. The present activity does NOT appear to be pronounced; it does NOT suggest that the fort is held in strength.

Supply of Steel Anti-tank Obstacles for Obstruction of Beaches

4. A good source reports on 7 April 1944 that all good trains leaving REMES for the coast contained several trucks loaded with pine-logs "for anti-tank defences", and comments that there is a shortage of steel and concrete for this purpose.

Comment:

The reference is clearly to underwater obstacles. The shortage of steel and concrete units is evident from air photographs, as well as from other sources.

Reports from NORMANDY and BRITANNY show that steel obstacles have been removed from coastal defences and from defended towns in rear of the coast to be used as underwater obstacles. It now appears likely that the steel obstacles were obtained entirely from these local resources, plus any small reserves of unused units available in the coastal areas. There is NO evidence of any large-scale movement of steel obstacles by rail or waterway from the interior of FRANCE, BELGIUM or GERMANY. The only plausible rail movement is one of ten trucks, which probably carried obstacles collected from various towns in BRITANNY to the coast. There is no evidence that new steel obstacles are being manufactured and dispatched to the coast, although this is NOT an impossibility. On the other hand, changes in underwater obstacles in the NEPTUNE area during the past two weeks indicate that the supply of steel obstacles at present available there may have been exhausted; the only additions of any note in that period are wood and concrete units.

Concrete underwater obstacles are known in all areas but still far from plentiful. The only units used which were previously in existence are German concrete stars, and these on a very small scale: none are known on the NEPTUNE beaches. Concrete tetrahedra have been made in FRANCE: see NEPTUNE ARGUS No.26, paragraph 5. Their numbers are probably still increasing, but they form a small fraction of all the obstacles used. The "box-type" obstacles, associated with mines, are an innovation; they appeared in early May and the scale of production is unknown.

*A. C. S.*  
Major-General,  
A. C. of S.

G-2

TOP SECRET  
BIGOT

0026

TOP SECRET  
BIGOTTOP SECRETARTILLERY IN THE NERTHE AREA  
1944Artillery in the NERTHE Area

1. VILLEWILLE                      Reference Map: G.S.G.S. 4250/726/480159  
 a concrete artillery observation post.  
Air Cover: Sortie J/910              Photo Nos: 4126-7  
 of 15 April 1944  
Comment:  
 This is probably the observation post for VILLEWILLE BATTERY at 486156. The observation post for this battery was known to be in a concrete and brick structure on the cliffs forward of the position, but had NOT previously been pinpointed.
2. ANANCERS                      Reference Map: G.S.G.S. 4250/641.  
Date of Information: 9 April 1944  
 Large camouflaged underground guns in the cliff.  
Comment:  
 NOT confirmed on photographs.
3.                                      Reference Map: G.S.G.S. 4250/726/4833.  
Date of Information: 20 April 1944  
 On the "plateau de DOLMART" (DOLMARD) there are two long range guns 18 metres long.  
Comment:  
 This probably refers to the three-gun superheavy battery at LE GRAND CLOS, 467307.
4. FOURTEEN NEVILLE              Reference Map: G.S.G.S. 4250/621/353290.  
 The three original guns of this medium battery are now in completed casemates 20 feet long by 27 feet wide, with No.1 facing North East and Nos.2 and 3 North. A fourth casemate 47 feet long and 43 feet wide, facing North East, has been completed 250 feet South East of No.1.  
Air Cover: Sortie 16/28              Photo Nos: 3167-8  
 of 22 April 1944                      4001-03  
 Sortie 1067/373                      3008-9  
 of 11 May 1944  
 Sortie 16/24A  
 of 22 May 1944.

/Comment:.....

CONFIDENTIAL

9 SP10

TOP SECRET  
BIGOT

0027

TOP SECRET

BIGOT

Comments:

The original three guns of this battery are medium naval coast guns, and were turret mounted before camouflaging began. The fourth casemate resembles those at LONGUES battery (725/797471), which probably house 155 millimetre coast guns. From the siting of the fourth casemate, it might be inferred that it is now the No.1 gun of a four gun battery. However, the gun is almost certainly a wheeled gun, of a type different from the original three, which would NOT be a usual procedure. Possibly this casemate contains a medium flare gun (Leuchtgeschutz) and is NOT part of the main armament of the battery.

5. NEVILLE Reference Map: G.S.G.S. 4250/792/151773.

Four guns are seen on the site of this old dummy position. The guns have appeared since 14 May 1944. They are well camouflaged in a hedgerow, and appear to be in open emplacements 15 feet in diameter, 45-50 yards apart. Trenching activity is visible, and two dugouts have been constructed.

Air Cover: Sertis 140/157 Photo No: 4085-9  
of 22 May 1944  
Sertis 16/259 4060-1  
of 24 May 1944

Comment:

Probably a field troop, possibly with 75 millimetre field guns.

6. GREENVILLE SEE MEZ Reference Map: G.S.G.S. 4250/792/261781.

These four occupied emplacements previously reported are now seen to be dummies.

Air Cover: Sertis 16/259  
of 24 May 1944

Comment:

Previously listed as 4 x 75 field guns.

7. SALLERVILLE Reference Map: G.S.G.S. 4250/792/123772.

A possible four-gun field battery, now since 11 May, is seen on the edge of the high ground overlooking the quarry. The four emplacements are about 14 feet in diameter, 30-55 yards apart, sited in an arc to fire almost due West across the River OISE. The objects in the emplacements are camouflaged. A number of vehicle tracks are visible in rear of the position.

Air Cover: Sertis 140/157  
of 22 May 1944

8. QUISTRENN Reference Map: G.S.G.S. 4250/792/10573A.

At this four-gun dummy for QUISTRENN battery (103779), No.4 position is now unoccupied, and what appears to be a flimsy dummy casemate has been constructed in front of it, with a runway linking the emplacement and the "casemate". No "casemate" was visible here on cover of 14 May.

/Air Cover:....

TOP SECRET  
BIGOT

0 0 2 8

BIGOT

- 3 -

Air Cover: Sortie 140/157      Photo Nos: 3111-2  
                  of 22 May 1944  
                  Sortie 18/217                      3063-4  
                  of 14 May 1944

Comment:

This is the first example of enemy camouflages in the NITRUS area. This is also the first example in the area of a camouflaged connected by runway with an alternative open emplacement. These have been seen, in connection with genuine batteries, at DUKKIK and LA HOCHILLE.

C-2 (Intelligence) Division,  
REF.  
26 May, 1944.

TOP SECRET  
BIGOT

7 7 1 0  
0 0 2 9



## BIGOT

TOP SECRET

APPENDIX 'C' TO NEPTUNE AREA NO. 29  
DATE 26 May 1944

Light Defenses in the NEPTUNE Area

1. GRAVE-sur-MER Reference Map: G.S.G.S. 4347, 37-18 SE.  
 Date of Information: 24 May 1944

A small strongpoint is under construction at 953852. There are four small excavations. One of the excavations and the path that leads to all four excavations is in the middle of a minebelt, which, therefore may prove to be a dummy.

Air Cover: Sortie 140/173 Photo Nos: 4040/1  
 of 24 May 1944

2. PORT-en-BUSSON Reference Map: G.S.G.S. 4347, 37-18 SW.  
 Date of Information: 22 May 1944

There is a pillbox at 73958821.

Air Cover: Sortie 140/157 Photo Nos: 4169  
 of 22 May 1944

3. GRANDEMER Reference Map: G.S.G.S. 4347, 34-18 NW.  
 Date of Information: 22 May 1944

There are emplacements (diameter approximately 14 feet) at 54429335, 54379328 and 54329344.

Air Cover: Sortie 140/157 Photo Nos: 4204/5  
 of 22 May 1944

4. BOUFFAY Reference Map: G.S.G.S. 4347, 37-18 SW.  
 Date of Information: 22 May 1944

A light gun in an open emplacement at 775875.

Air Cover: Sortie 140/157 Photo Nos: 4163/4  
 of 22 May 1944

5. LONGUES Reference Map: G.S.G.S. 4347, 37-18 SW.  
 Date of Information: 22 May 1944

Two small trench systems at 813872 and 813873.

Air Cover: Sortie 140/157 Photo Nos: 4154/5  
 of 22 May 1944

6. BELLES Reference Map: G.S.G.S. 4250, 86/5.  
 Date of Information: 30 January 1944

Two dug-outs for machine guns or pillboxes at approximately 686015. An observation post and two machine gun posts in square 7201.

Air Cover: None

TOP SECRET  
 BIGOT

9SP10

0030

BIGOT

- 2 -

7. MAJOLIE Reference Map: G.S.G.S. 4250, 80/5.  
Date of Information: 30 December 1943  
There is an observation post and a machine gun post on the West side of the road in square 4991.  
Air Cover: None
8. VILLEPS-sur-TER Reference Map: G.S.G.S. 4347, 43-18 SW  
Date of Information: 22 May 1944  
Two pill shelters at 30128337.  
Air Cover: Sortie 140/157 Photo Nos: 4052/3  
of 22 May 1944
9. LE MAIR Reference Map: G.S.G.S. 4249, 7E.  
Date of Information: 2 May 1944  
There is a machine-gun post on each side of the road at approximately 302805.  
Air Cover: None
10. CIF de CARTHEM Reference Map: G.S.G.S. 4347, 28-18 NE.  
Date of Information: February 1944  
There are three guns, calibre NOT known, in the area of 991943.  
Comment:  
One unspecified weapon is shown in the "Stop Press" overprints, but the other two are NOT seen on air cover.
11. LOSSIERE Reference Map: G.S.G.S. 4347  
Date of Information: 19 May 1944  
Four probable dug-outs under construction\* and a large weapon pit at 262053.  
Air Cover: Sortie 106G 434 Photo Nos: 3350  
of 19 May 1944
12. MONTENOURG Reference Map: G.S.G.S. 4347, 31-20 SE.  
Date of Information: 19 May 1944  
Four dug-outs or boys under construction at 311059.  
Air Cover: Sortie 106G 434 Photo Nos: 3372  
of 19 May 1944
13. LE MAIR Reference Map: G.S.G.S. 4250, 80/5.  
Date of Information: 11 April 1944  
There are two pillboxes at approximately 407350 near the /junction.....

TOP SECRET  
BIGOT

0031

# BIGOT

- 3 -

Junction of Rue de Chancy and Rue Barthelot and another at 407357 in  
Rue de Chancy.

Air Cover: None

14. REPORTS-GENERAL

Reference Map: S.C.G.S. 4347, 54-18 177.

Date of Information: 22 May 1944

There are three small pits at 49959115, four small pits  
and one weapon pit at 49679108.

Air Cover: Bertie 140/157  
of 22 May 1944

Photo Nos: 3252/3

Comment:

The pits are slightly smaller than weapon pits, but they  
may be developed.

G-2 (Intelligence) Division,  
SICP.  
26 May, 1944.

TOP SECRET  
BIGOT

0 0 3 2

## BIGOT

TOP SECRET.APPENDIX 'M' TO REPORT AREA NO. 29  
WESTERN REPORT NO. 102.FIELD REPORTS IN THE NORTH AREA.GENERAL NOTES.

1. LE HAVRE. Reference No: C.S.G.S. 4250/77A. & 823.

The beam to the EAST of the E/R boat shelter appears to have been removed.

Source: Air Date of Information: 3 May 1944.

Air Cover: Good.

Amendment to: Appendix 'M' to REPORT SUPPLEMENT NO. 17.

2. Reference No: C.S.G.S. 4250/821.

A B/ has heard that there are sea mines just outside the harbour of ST. P, which can be electrically detonated from a bunker on the WEST side of the harbour area.

Source: Ground Date of Information: December 1943.

Comment:

This is confirmation of the minefield, which was previously reported.

See Appendix 'P' to REPORT AREA NO. 13, paragraph 1.

3. ROUEN. Reference No: C.S.G.S. 4250/925.

The GERMANS have not, so far, made any attempt to dismantle the gear in the port, neither had they started any demolition preparations. There had been rumours at the end of January 1944 that charges were to be laid against the main cranes, but no signs of any work of this nature had been seen.

Source: Ground Date of Information: 5 May 1944.

Comment:

This conflicts with a report of 7 January 1944, issued in 'CERTAIN REPORT NO. 91. In view of the extensive demolition preparations in other ports in the area, it is probable that preparations have been made at ROUEN.

Reference to: REPORT SUPPLEMENT NO. 21, paragraph 32.

4. Reference No: C.S.G.S. 4250/925.

There is one minefield in the SEINE known to a ground source. This is located where the river turns SOUTH at the bend by PORT QUEVILLY; the mines here are shore controlled.

Source: Ground Date of Information: 5 May 1944.

/Comment.....

CONFIDENTIAL

95710

TOP SECRET  
BIGOT

0033

## BIGOT

-2-

Comment:

The report indicates that this minefield is somewhere near the grid square at G.S.G.S. 4250/795/1414. The only minefield known up to this time in the SEINE river is at the TONNEVILLE CANAL lock. This minefield was also reported to be controlled.

5.

Reference Map: G.S.G.S. 4250/794 & 823.

The number of lighters scuttled along the DEWEE NOUD and the beach BENT of it has increased to 39. The line of grounded obstacles running EAST-NORTH-EAST from the SOUTH-EAST corner of the BASSIN de LAKE is now identified as a line of grounded pentoons, four of which are BEINGS units. Immediately NORTH of the end of this line of pentoons, starting just above low water is a line of 12 ballasted lighters also running EAST-NORTH-EAST more or less parallel with the waterline, extending as far EAST as the SOUTH-EAST corner of the reclaimed land (51422425).

Source: AirDate of Information: 3 May 1944.Air Cover: Good.Appendant to: Appendix 'B' to REPULSE SUPPLEMENT NO. 17.

C-2 (Intelligence) Division,  
 \_\_\_\_\_  
 26 May 1944.

TOP SECRET  
 BIGOT

7 7 2 5  
 0 0 3 4  
 E

## BIGOT

TOP SECRET

APPENDIX 'E' TO NEPTUNE ARCUS NO. 29.  
Dated 26 May 1944.

Obstacles in the NEPTUNE Area.(a) Underwater Obstacles.1. ST. PIERRE-SOLEUR Area. Reference Map: GSGS 4347/31/22 SE

Good cover of 22 May enables a fuller description of the underwater obstacles in this area to be given. The following detailed account of the whole area includes a number of recent extensions:-

26402832 - 26522831	Two rows, ? hedgehog.
26512834 - 26572834	Single row, ? hedgehog.
26532831 - 26652830	26842836 Single row, ? hedgehog.
29432925 - 30682948	Two rows, ramps, mixed with unidentified obstacles, previously referred to as "mounds".
31682948 - 31872964	Obstacles still unidentified.
31872964 - 32742962	Stakes in groups of three with ramps between and in front. "Mounds" on seaward side.
32742962 - 32872957	"Mounds".
32872957 - 33032953	Stakes and "mounds" 3 rows.
33032953 - 33582953	? Ramps and "mounds".
33582953 - 34332907	Ramps, stakes and "mounds".
34332907 - 35232900	Single row, ramps.
36142857 - 36872836	Single row, ramps.
37002830 - 37262813	Two rows, ramps.
37552800 - 38432780	Single row, ramps.

Air Cover: Sorties 16/244 and  
 1066/455 of  
 22 May 1944.

2. POINTE DU NEU Reference Map: GSGS 4347/31/22 SW

The two rows of underwater obstacles between 20962481 and 20502454, reported in para. 3 of Appendix 'n' to NEPTUNE ARCUS NO. 27, are now seen more clearly. They are probably tetrahedra.

Air Cover: Sortie 16/244 of Photo No: 4064  
 22 May 1944

3. FRANCEVILLE-PLAGE Reference Map: GSGS 4347/40/16 NW

Between 130791 and 133792 obstacles have been thickened by the addition of stakes and ramps. The average distance between units is approximately 35 feet.

Air Cover: Sortie 140/157 of  
 22 May 1944

G-2 (INTELLIGENCE) DIVISION  
 SHARP.  
 26 May 1944.

TOP SECRET  
 BIGOT

0035

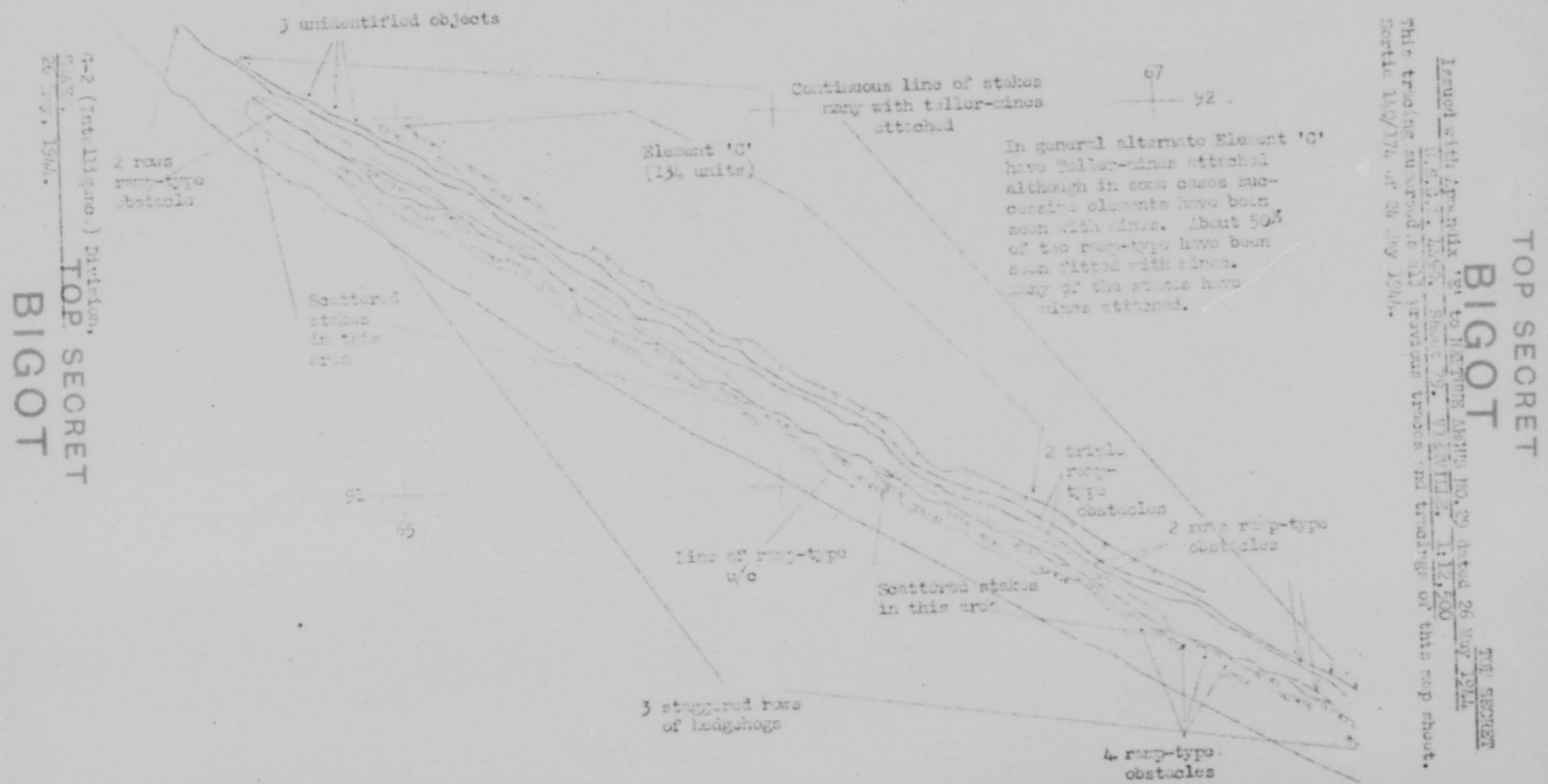

0036



BIGOT

TOP SECRET

ISSUED WITH APPENDIX E TO MESSAGE AGENC 14, 49  
DATE: 25 MAY 1954

U.S.C.S. MAP Sheet 70 BY TIAST-44-1007E  
1:12,500

The information below is additional to that shown on the tracing issued in the MESSAGE AGENC 14, 49.

Article 140/74 of 24 May 44.

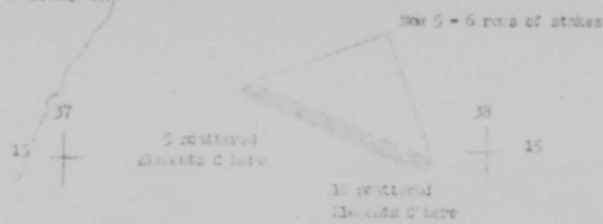

U.S.C.S. MAP Sheet 80. COLLEVILLE  
1:12,500



These map-type obstacles, 9 in all, are closely spaced in three to gaps between 4 of the obstacles C.

Slight attention to line of map-type

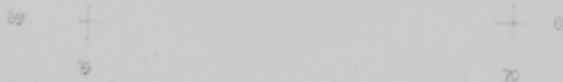

The information above is additional to that shown on the tracing issued in the MESSAGE AGENC 14, 49.

Article 140/74 of 24 May 44.

G-2 (Intelligence) Section,  
SMF.

TOP SECRET  
 BIGOT

0037

BIGOT

TOP SECRET

Issued with Appendix 'E' to REPORTS AECUS NO. 29 dated 26 May 1944

G.S.G.S. M.90. Sheet 85. INC-SUE-MER. 1:12,500

The information below is additional to that shown on the tracing issued in the REPORTS AECUS NO. 7. Sortie 400/157 of 25 May 1944.

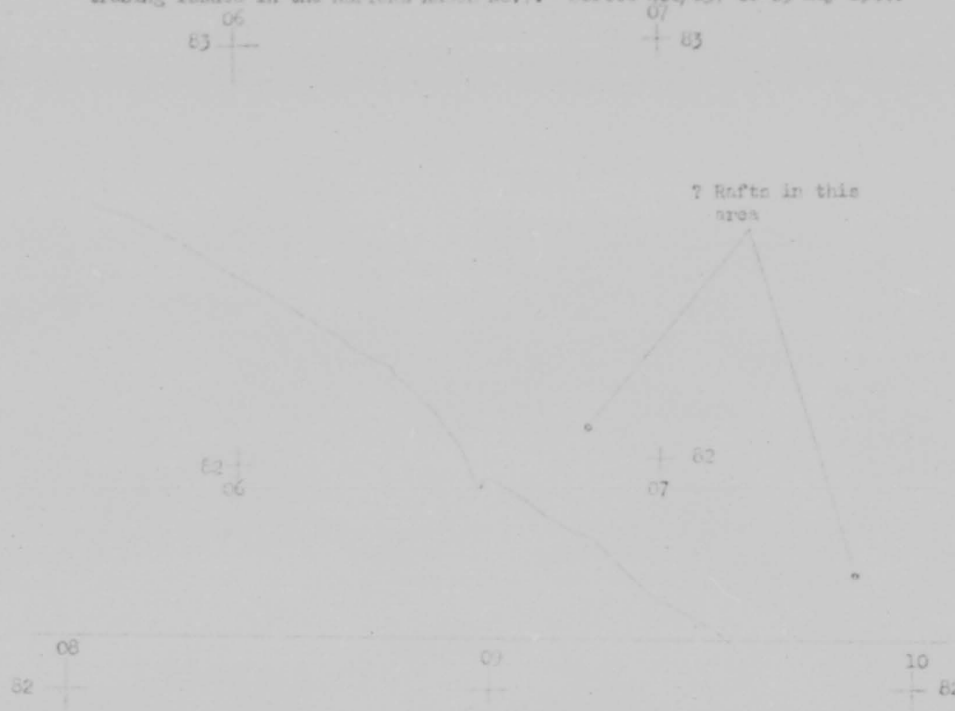

G.S.G.S. M.90. Sheet 86. QUETREVA. 1:12,500

The information below is additional to that shown on the tracing issued in the REPORTS AECUS NO. 7.

Sortie 400/157 of 25 May 1944.

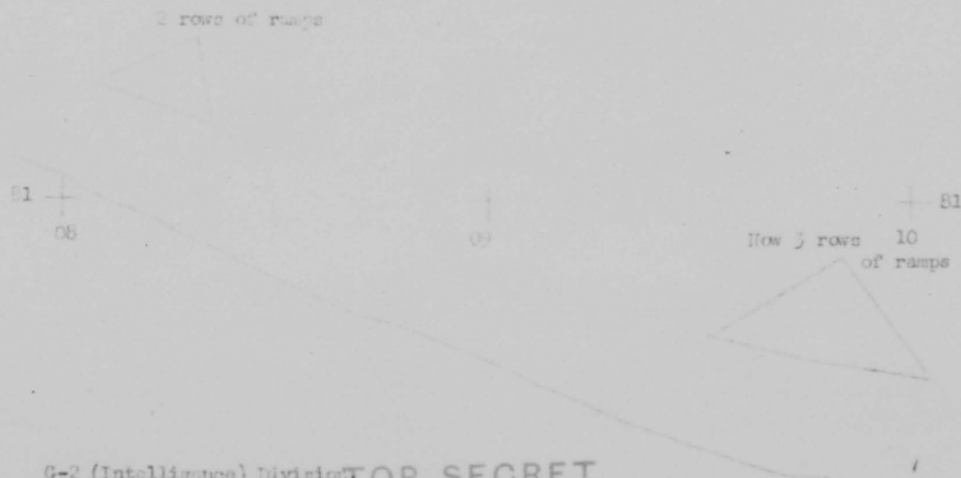

G-2 (Intelligence) Division  
SHARP.  
26 May, 1944.

TOP SECRET  
BIGOT

0038

APPENDIX 'G' TO REPORT TOP SECRET  
 Dated 26 April 1944.  
**BIGOT**  
 AMMUNITION DUMPS

TOP SECRET.

1. ZELMER, ESTER/ Reference Map: GSGS 4040 1/47 W  
BOIS DE POISSON  
 (GREN)  
 Date of Information: March 1944.

There is an ammunition dump in grottoes near ZELMER-ESTER  
 (at approximately 167662). The ammunition, which supplies part of the  
 needs of IWR in the area, is protected by 6-10 metres of earth and  
 calcareous strata. It is near the railway line, and before the war was  
 used by the French A.M.

Source: Ground

Air Cover: None.

Assignment to: TIS/P.IV/IR/8.2

2. CHATEAU DE BOIS DE POISSON Reference Map: GSGS 4040 1/59 W/976147  
(COULES DE BOIS)  
 Date of Information: 6 April 1944.

Ground source reports an ammunition dump in BOIS DE POISSON  
 (976147), near CHATEAU DE BOIS DE POISSON.

Air Cover: Service No. 200 Photos nos. 5041/2  
 26 April 1944.

Comment:

Dump confirmed by air cover. On both sides of the road from  
 973151 to the Chateau at 976145 can be seen 12 objects approxi-  
 mately 25' square, straggled to averaging 75 yards apart. There  
 are signs of a surrounding belt of wire.

3. CHATEAU DE GARENNE Reference Map: GSGS 4250/836/0507  
 (GREN)  
 Date of Information: 14 March 1944.

The "craftsman" of the G.T., with his staff and drafting  
 office, is installed in a small brick chateau on the hillside 100  
 metres from the installations.

Air Cover: None.

4. FOREST: VILLE DE LA- Reference Map: GSGS 4250/805  
CHATEAU  
 (GREN)  
 Date of Information: 10 May 1944.

The district along the edge of the FOREST DE PERCHIE, from  
 the town of PERCHIE (Backwards ?) has been evacuated. Everything is  
 underground next to the chateau ("Chateau" not located).

Source: Air, Ground

Air Cover: Good. Photos nos. 4046/55  
 Service: 16/221  
 of 15 May 1944.

Comment:

Air cover of edge of forest from 516002 to 405030 shows only that  
 an excavation is being dug at 470045.

Assignment to: TIS/P.IV/IR/8.2

/5. CHEMBOURG.

0039

BIGOT

- 2 -

5. CHEVIGNY/SAINT-REMY Reference Map: GCG 4250/522/1024-1025  
(UNCS)

Date of Information: 8 May 1944.

On 12 December 1941 ten road served entrances probably giving access to granitic stacks beneath the hillside were reported from 105241 to 106250. Between 28 October 1943 (E/441) and 5 January 1944 (E/970) a few stores appeared on the level ground in front of the entrances, but no other sign of activity was seen. On 2 March 1944, however, it became clear that further work had been undertaken here (See B. 805 of 8 March 1944). An erection of camouflage netting to scaffolding was being put up in front of the third and fourth entrances (counting from North to South) into the hill; and the presence of stores and of a light railway, on which a moving train was seen indicated activity.

Photographs of 8 May 1944 show that considerable progress has taken place during the last two months. Entrance No. 2 has been covered over with camouflage netting. An irregular shaped building is in course of construction beneath the camouflage in front of entrances 3 and 4 and extends South almost as far as No. 5. The area camouflaged measures very approximately 250' x 300'. Further camouflaged areas extend forward for approximately 200' in front of Nos. 8 and 9. New branches of light railway, signs of spoil, tracks and a number of piles of stores and material can be seen on the level ground throughout the width of the small valley in which the entrances are situated.

Air Cover: Sortie 1064/313 Photo nos. 3431/3  
of 8 May 1944.

6. HEBREVILLE Reference Map: GCG 4250/522/0825  
(UNCS)

Date of Information: 11 May 1944.

Air cover shows that the quarry adjacent to the main road at 083252 appears to be no longer used for cutting stone, as there are no signs of recent removal of stone and the mainface is covered with natural growth. There are, however, considerable signs of track activity in the quarry and three tracks approximately 9' wide lead directly into the face and sides of the quarry, suggesting the presence of underground storage. Objects which may be miscellaneous stores are visible on the floor of the quarry.

Air Cover: Sortie 1064/368 Photo nos. 3031/2  
of 11 May 1944.

7. FRANCE: VIEUX/CHENTRES Reference Map: GCG 4250/626/718295  
(UNCS) (station)

Date of Information: 2 May 1944.

At CHENTRES (not shown on the GCG map), in the area bounded approx. by points 700 m. from VIEUX station (718295), 500 m. from the road VIEUX-MASSY and 400 m. from the village of VIEUX-LE-PEU, a large number of French labourers have been working for about five months on underground installations, the purpose of which is as yet undetermined.

Source: Ground

Air Cover: None

TOP SECRET  
BIGOT

/Document:.....

0040

## BIGOT

- 3 -

Comment:

A previous ground report of January 1943 mentioned the same activity in this area.

Applicant to: TIA/D.W./RMP/8.2

8. HAUTES  
(SOUTH BY OISE)

Reference Map: G.O.S 4250, 22/4.

Date of Information: January 1944

Amunition dumps are being set up in underground quarries and mushroom caves which are NOT too deep.

Air Cover: None

Comment:

NO particular underground storage site has yet been reported near HAUTES but it is likely that caves in the area have been inspected with a view to their conversion into dumping sites.

9. LA FERTE-ST-JEAN/CHVILLAY  
(LOBERT)

Reference Map: Air 5000/95 ST.  
47° 45' N.,  
00° 25' E.P.

Date of Information: 15 April 1944

There is an ammunition factory and dump at CHVILLAY (5 kms. NW of LA FERTE-ST-JEAN). The factory and dump buildings are spread out for a distance of 1.5 kms. along the NW side of the road from LA FERTE to BRACH. Constructed before the War, the factory and dump are for the most part camouflaged in the wood. The factory makes cartridges and small calibre air shells. The Germans are constructing new buildings and intend to begin the construction of a railway spur to the dump.

Air Cover: Sottis 22/759 Photo Nos: 10119 and 5096/7  
22/605  
of February 1944

Comment:

This installation is not mentioned in SOTTIS (1939). However, a SOCIÉTÉ INDUSTRIELLE MANUFACTURÈRE ET COMMERCIALE is listed in 1939 telephone Directory.

Air Cover of February 1944 shows what appears to be an explosives filling factory consisting of four groups of buildings, several of which are storage units with blast protection. The site covers an area of approximately 330 acres and is surrounded by wire. It is road access from railway and ROUTE NATIONALE 20 at 47° 45' 45" N., 00° 24' 10" W. of PARIS.

It is possible that the factory can be classed as a Hobersmann.

/10. ...LIDON...

TOP SECRET  
BIGOT

0041

TOP SECRET  
BIGOT

- 4 -

10. HESTICH  
(HELVETIA)Reference Map: GSGS 4250/74/26622  
34734

Date of Information: October 1943

Informant reports exist here of an ammunition dump near HESTICH Railway station, next to the railway line. Former French depot, employing about 100 workers in October 1943. No AA defenses visible in vicinity.

Air Cover: Bertie 12/956      Photo Nos: 5001/5  
of 3 January 1944

Comment:

Recent air cover seemed to indicate that this dump was inactive.

11. ST. 10/24 DEWABEREN  
(LUXEMBOURG)

Reference Map: GSGS 4250/67/545671.

Date of Information: 25 February 1944

There are at least 35 irregularly shaped patches in the woods which may be camouflaged supplies. They are located near the road traversing the area. Type of supplies not known. Possible ammunition dump?

Air Cover: Bertie 12/253      Photo Nos: 5001/42  
of 25 February 1944

C-2 (Intelligence) Division,  
-----  
26 May, 1944.

TOP SECRET  
BIGOT

0042

TOP SECRET

TOP SECRET

APPENDIX I TO INTERIM REPORT NO. 29  
Dated 26 May 1944

BIGOT

W/T Installation near the BUREAU LAURE

1. ST. JEAN DE CHIGNASSAIS Reference Map: 4040/76 N.E./621770  
(N. 1000)

Date of Information: 16 May 1944.

$\frac{1}{2}$  mile North-East of ST. JEAN and just East of farm at LA  
CHIGNASSAIS. Blast wall protected building 30' x 25' with two machine  
guns.

Air Cover: Sortie 22/365  
of 28 March 1944.

Photo nos. 4050

Comment:

No mast is visible but this is probably part of an enemy air-  
craft reporting system and as such would be equipped with  
W/T.

2. ST. JEAN DE LA VON Reference Map: Air 5000/80 N.E./  
(N. 1000) 48°24' N.  
2°12'53" E.

Three quarters mile South-East of centre of "FORGUES" and  
500 yards East of station. Single mast 211' to East of building 150' x  
42' which presumably houses transmitting apparatus and which forms part  
of a military school.

Air Cover: Sortie 23/163  
of 24 April 1944.

Photo nos. 5004

Comment:

Other sources locate W/T installation near this site.

3. LOIRE Reference Map: Air 5000/107 S.E./  
(N. 1000) 47°24'50" N.  
0°59'12" E.

In the grounds of the Chateau d'Arboise overlooking the LOIRE  
river. One slender mast 51' tall, East of small building which pro-  
bably houses transmitting apparatus.

Air Cover: Sortie 23/363  
of 5 March 1944.

Photo nos. 4037

Comment:

Other sources locate W/T installation at this site.

4. CHERBOURG/LES BOUES Reference Map: 4250/524/105195  
(N. 1000)

Date of Information: 13 May 1944.

$2\frac{1}{2}$  miles South-East of CHERBOURG. 2 masts 77' high and 122' apart.  
Building 66' x 32' between the masts. Numerous huts around.

Air Cover: Sortie 106 W/363  
of 11 May 1944.

Photo nos. 3010

Comment:

This is probably a headquarters with a W/T communication station.

TOP SECRET

/5. CHERBOURG....

0 0 4 3



TOP SECRET  
BIGOT

5. CHEBOURG/OCTEVILLE Reference Map: 4250/6E1/133215  
(RUNCHE) Date of Information: 18 May 1944.
- W/T station under construction. Three masts 157' high put up; foundations for a fourth being dug.
- Air Cover: Sortie 1067/357 Photo nos. 4014  
of 10 May 1944.
- Comment:
- Ground source adds the following: This station is one of a series of 75 to be erected between BELGIUM and GERMANY. Transmitting and listening posts are already finished. Three pylons have been erected; five others of the same size planned. The entire zone is occupied by Germans, who have below the Chateau Maurice a real underground city here - some galleries are as much as 120 m. long. Chateau Maurice is the headquarters of the Naval Signal Offices (M.N.O.) and is linked by buried cable to the W/T station. There is no confirmation that 74 other stations of this type will be built.
6. TOURS Reference Map: 4250/8J4/755659  
(MURE ET LOIRE) Date of Information: 30 December 1943.
- THIERS. Three W/T pylons are reported in the CASERNE D'ILHERS, BOULEVARD
- Air Cover: None
7. ST JACQUES DE LAUNDE Reference Map: 4040E/75 S.E./976503  
(HEE ET VILLENE) 963503  
974520
- Date of Information: 24 February 1944.
- Source locates "listening apparatus" at the first point, and radio apparatus at the other two.
- Air Cover: None
- Comment:
- The pinpoints given are approximate. The three stations are just North of ST. JACQUES DE LAUNDE Airfield. The type of installation can NOT be determined from the information given.
8. LISEUX Reference Map: 4250/8F1/5667  
(C.LVADCS) Date of Information: September 1943.
- Radio post near the locomotive depot.
- Comment:
- Exact location not clear from plan supplied.
9. DEANVILLE Reference Map: 4250/7E6/443122  
(C.LVADCS) Date of Information: September 1943.
- Source reports five pylons at about above point.
- Air Cover: .....

TOP SECRET  
BIGOT

0044

TOP SECRET  
BIGOTAir Cover: NoneComment:

Information does NOT seem it possible to determine the function of this radio installation.

10.

ST. PIERRE DE QUEN  
(Quen)Reference Map: 308/603953Date of Information: 30 January 1944.

Near village of LE TRENNE, a watch post is under construction.

Air Cover: NoneComment:

It is possible that wireless will be installed.

11.

CHATEAU DE VILLERS  
(CHATEAU DE VILLERS)Reference Map: 40408/75 38/522411

In the grounds of the Chateau DE LA MASSE 8 miles South South-West of CHATEAU DE VILLERS is a W/T station with at least one mast 80' high in front of Chateau defended by light anti-aircraft, trenches and wire.

Air Cover: Sertic 765/1331  
of 7 May 1944. Photo nos. 4099Comment:

This station has already been reported several times by ground sources who state that there are 4 to 6 masts in the grounds of the Chateau. This station is reported to communicate with submarines.

12.

LE NEUVIL HALLWAY  
(LE NEUVIL)Reference Map: 4250/376/059591

On eastern edge of CONGRES airfield just West of LE NEUVIL HALLWAY two slender masts 57' tall, blast wall protected building 45' x 25' midway between them.

Air Cover: Sertic 1064/95  
of 23 April 1944. Photo nos. 3009Comment:

Probably part of facilities of CONGRES airfield.

13.

HEADQUARTERS  
(HEAD OF VILLERS)Reference Map: 4250/306/945793Date of Information: 12 May 1944.

This station is now seen to be a battery of three D/T Adcocks and a Headquarters. Most Southerly Adcock at 945743. New H/F I/F under construction at 941801. The third Adcock is 1 mile from 945743 on a bearing of 355° T. The three Adcocks are connected by cable to a building at 947003.

Air Cover: Sertic 88/218  
of 27 April 1944. Photo nos. 12048Comment:

This station has been reported previously, but without the full details above.

TOP SECRET

/14. ST. QUEN .....

BIGOT

0045

TOP SECRET  
BIGOT

- 4 -

14. ST. OUSE Reference Map: 4250/1183/442071  
(SEINE ET MARNE) Date of Information: 12 May 1944.
- Half a mile West North-West of church in ST. OUSE. A possible W/T station is under construction. Blast wall protected hut 31' x 18'. A possible mast.
- Air Cover: Sortie BR/78 Photo nos. 13065  
of 19 April 1944.
- Comment:
- This is probably part of the enemy's aircraft reporting system and would therefore be equipped with W/T.
15. SELAN/LASSY Reference Map: 4250/1061/993291  
(SEINE) Date of Information: 12 May 1944.
- 3 miles North of SELAN, 400 yards East of LASSY. Two masts 57' tall, 259' apart. Blast wall protected building 26' x 20'. Square tower and huts. There may be other masts.
- Air Cover: Sortie 1061/95 Photo nos. 3105  
of 25 April 1944.
- Comment:
- Other sources state there is a W/T installation at LASSY.
16. LE BLANC MONT Reference Map: 4250/1044/148547  
(SEINE ET OISE) Date of Information: 12 May 1944.
- Four masts in shape of rhomboid, hut 13' x 9'.
- Air Cover: Sortie BR/78 Photo nos. 12111  
of 19 April 1944.
- Comment:
- This W/T station is probably part of the facilities of LE BOURGET airfield.

C-2 (INTELLIGENCE) DIVISION  
 [REDACTED]  
 26 May 1944.

TOP SECRET  
BIGOT

0046

TOP SECRET  
BIGOT

TOP SECRET

APPENDIX 'K' TO NEPTUNE AREA NO. 29  
Dated 26 May 1944Stores dumps in the NEPTUNE Area

1. CARENTAN (MORBIEN) Reference Map: G.S.G.S. 4250/625/3984.  
Date of Information: March 1944

CARENTAN is the supply centre for troops stationed in the department of MORBIEN.

Air Cover: None

Comment:

A previous report stated that German supplies services in CARENTAN were established in ECOLE DES FILLES on Rue SICARD DE BEAULIEU.

2. LA FLECHE/TROSEE (MORBIEN) Reference Map: G.S.G.S. 2736, 14.  
Date of Information: February 1944

The Germans have set up a supply depot near TROSEE-LES-PINS.

Air Cover: Sortie 140/41 Photo Nos: 4077/B  
of 24 April 1944

Comment:

It is likely that source refers to the large stores dump at 270020. Photographs show sheds on sidings. This is the first ground information concerning this site.

3. PONT L'EVESQUE (MORBIEN) Reference Map: G.S.G.S. 4250, 88/1.

The supply services for the coastal area are in the hutments located opposite the railway station (526038).

Air Cover: None

4. CHARENTEN (SURE ET LOIR) Reference Map: G.S.G.S. 4250/964.  
Date of Information: May 1944

At 374015, in the area enclosed by the railway and road fork, there is a large depot. The main feature is a building with a ridged roof 310 feet square. Adjacent are two similar types of buildings 150 feet square. There are 15 smaller buildings in the area. The depot extends North of the road at 374017 where a shed 250 feet x 150 feet is the main feature and adjacent are 4 sheds 150 feet x 45 feet. The roofs of the larger buildings have been disruptively painted. Between 30 and 40 M.T. can be seen in the two areas.

Air Cover: Sortie US 34/239 Photo Nos: 5001B, 02B  
of 1 May 1944

Comment:

Buildings in this area reported by ground sources to be used as food supply depot.

TOP SECRET  
BIGOT

/5.....

0047

TOP SECRET  
BIGOT

- 2 -

5. CASEI

Reference Map: G.S.G.S. 4250, 7F/1.

Date of Information: October 1943

A food dump is located in a hangar on QUAI DE VINCENNES (057664). There is always a sentry on duty at this dump. Bread is distributed at 0600 hours every morning from this point by a detail of 30 men. The bread which is stored in bags, comes from the former powder factory of COGNELLES LE ROYAL (059651) which holds an important supply dump.

Air Cover: NoneComment:

The hangars on QUAI DE VINCENNES are confirmed as stores and supply dumps.

6. EVREUX

Reference Map: G.S.G.S. 4040A, 47 NF.

Date of Information: April 1944

The annexe to CASERIE TILLY at 177691 is used as a supply depot. There are two civilian guards.

Air Cover: None

G-2 (Intelligence) Division,  
SHAET.  
26 May, 1944.

TOP SECRET  
BIGOT

0048

23/00/132/1.

CHIEF'S HEADQUARTERS  
 ALLIED EXPEDITIONARY FORCE  
 G-2 (INTELLIGENCE DIVISION).

TOP SECRET  
 BIGOT

TOP SECRET.

COPY NO: 101

28 May 1944.

---

 NEPTUNE ARGUS NO. 31
 

---

With this report :

- Appendix 'A' - Artillery
- Appendix 'B' - Obstacles
- Appendix 'I' - Signals Installations

Floating raft obstacles.

1. A tracing was issued in NEPTUNE ARGUS NO. 30 showing a number of floating obstacles in the area of VERMOREL-VER (G.S.C.S. 4490/33). These obstacles were resting at points varying between five and eight feet above chart datum, i.e. considerably lower down the beach than most other obstacles, which are normally sited between twelve and eighteen feet above chart datum. The blocks to which they are moored can NOT be seen on this cover. It should be noted that it is NOT possible to estimate accurately at what point these obstacles are liable to be set, as the points at which they come to rest on the beach at low tide vary considerably according to the state of the wind and currents.

Attacks on Enemy Radar Installations.

2. Results of attacks against enemy radar installations up to 24 May 1944 are NOT yet fully known, but the evidence suggests that the attacks have been on the whole successful and the vulnerability of the radar chain proved. 'Chimneys', 'Heardings', Troys and Great Ausburgs have been attacked and hits have been registered on all. Attacks against 'Chimneys and Heardings', which are the most conspicuous targets, have been probably most effective - the USMC. BARRAGE and BARRAGE BATTERY installations being rendered unserviceable. So far as is known, however, it has NOT been possible to destroy all the equipment at any one particular station.

Underwater Obstacles and Mines.

3. A new source reports underwater mines of the following type at DIEPPE. The mine is contained in a rectangular concrete block, the dimensions of which are not stated. Attached to the block by a number of wires is a spherical glass ball, which floats on the surface. Source states that it is sufficient for a boat to touch the glass ball to detonate the mine. The mines are moored in a chain about 100 yards "from the coast". Since 24 April 1944, small fishing boats have been forbidden to leave DIEPPE harbour, because two boats had been blown up by these mines.



0049



CHIEF'S HEADQUARTERS  
ALLIED SUBMARINE FORCE  
G-3 (OPERATIONAL INTELLIGENCE)

TOP SECRET  
BIGOT

REF ID: A66710

28 May 1944.

HEPTUNE ARGUS NO. 34

With this report :

- Appendix 'A' - Artillery
- Appendix 'B' - Obstacles
- Appendix 'I' - Signals Installations

Floating raft obstacles.

1. A tracing was issued in HEPTUNE ARGUS NO. 30 showing a number of raft obstacles in the area of VEG GUN-DEK (G.3.C.3. 4190/31). These obstacles were resting at points varying between five and eight feet above chart datum, i.e. considerably lower than the beach than most other obstacles, which are normally sited between twelve and eighteen feet above chart datum. The blocks on which they are moored can NOT be seen on this cover. It should be noted that it is NOT possible to estimate accurately at what point these obstacles are liable to be met, as the points at which they come to rest on the beach at low tide vary considerably according to the state of the wind and currents.

Attacks on Enemy Radar Installations.

2. Results of attacks against enemy Radar installations up to 24 May 1944 are NOT yet fully known, but the evidence suggests that the attacks have been on the whole successful and the railway utility of the Radar chain proved. 'Chimneys', 'Hearings', Poyan and Grant Gasburgs have been attacked and hits have been registered on all. Attacks against 'Chimneys and Hearings', which are the most conspicuous targets, have been probably most effective - the CHIFF. CHIFF and ROYAL/LA BELLEVUE installations being rendered unserviceable. So far as is known, however, it has NOT been possible to destroy all the equipment at any one particular station.

Underwater Obstacles and Mines.

3. A new source reports underwater mines of the following type at DIEPPE. The mine is contained in a rectangular concrete block, the dimensions of which are not stated. Attached to the block by a number of wires is a spherical glass ball, which floats on the surface. Source states that it is sufficient for a boat to touch the glass ball to detonate the mine. The mines are moored in a chain about 200 yards "from the coast". Since 24 April 1944, small fishing boats have been forbidden to leave DIEPPE harbour, because two boats had been blown up by these mines.

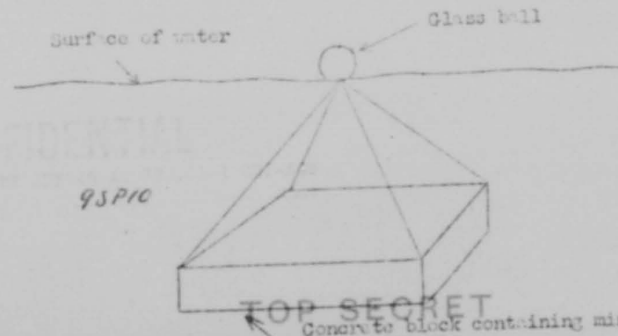

/Comment.....

TOP SECRET  
Concrete block containing mine.  
BIGOT

0050



## BIGOT

- 2 -

Comment:

It is NOT clear whether the mines are laid below LMI or above it; from the context, the former appears more likely. The glass ball may really serve to mark the position of the mine and NOT as a firing device. If the mechanism were as delicate as stated in the report, floating wreckage or even waves might be expected to detonate the mines.

It is NOT known whether these mines have any connection with the concrete boxes which have recently appeared on beaches in NORMANDY. Concrete boxes are NOT yet confirmed at DIEPPE itself. The report is possibly garbled.

4. A usually reliable source reports the following underwater obstacles in SOUTH WEST FRANCE: date of information 23 Apr 1944

- (a) At CAP FREGET, NORTH of ARLICHON, the GERMANS have carried out experiments by laying concrete blocks on top of which were fitted iron rails. The obstacles did NOT remain in place owing to the force of the sea and tides.
- (b) At MAILLONEYS, SOUTH of ARLICHON, there are concrete blocks in which are fixed iron anti-tank rails. There are three rows of these rails, one at LMI, one about half-way up the beach and the third at HMI. The concrete blocks in each line are connected to each other by steel tubes.

Comment:

Another very good source has reported "rails in a concrete foundation" in SOUTH WEST FRANCE. It is noteworthy that no mention is made of mines. There is no confirmation of the "steel tubes" story from photographs of concrete boxes on beaches in NORMANDY. The destruction of the obstacles in this area by the sea is NOT surprising; other obstacles, particularly stakes, are said to have been swept away by the ATLANTIC breakers.

5. Photographs of 27 May covering FORT MCHON PLAGE confirm what might be suspected from the above reports paras 3 and 4, that there is more than one type of concrete "box" device. At FORT MCHON PLAGE, no less than four different types of "box" are seen in a small dump near the beach. The smaller types may indeed be blocks, and NOT boxes, since no hole can be seen in the top, although this may be because they are lying on their side. These small blocks may only be supports for hedgehogs and tetrahedra. The larger types are similar to the boxes containing rails and posts already seen on beaches in NORMANDY. Details will be issued in NEPTUNE ARGUS No: 32 (Sortie 16/298, received at TIS at 1900 hours 28 May 44: this is the first example of the new method of large scale vertical photography and is remarkably successful).

6. Wire on Underwater Obstacles

The same sortie (16/298) shows wire, apparently fairly substantial, between underwater obstacles on a beach NORTH of the SOEBE estuary. Two rows out of four are wired. Details will be issued in NEPTUNE ARGUS No: 32.

*B. J. H. Griffin*  
Major-General,  
A.C. of S.,  
G-2.

TOP SECRET  
BIGOT

0051

TOP SECRET  
BIGOTAPPENDIX 'A' TO INTERVIEW REPORT NO. 31  
Dated 22 May 1944

TOP SECRET.

Artillery in the METZIER Area.A. BOB DAMAGE REPORTS.1. LA FERRIERE.

Reference Map: G.S.G.S. 4250/623 &amp; 4/365199

The four 170 mm guns of this battery, reported to have been removed on 19 May, are now seen to have been in position during the recent raid which demolished the four casemates under construction. No. 4 gun was probably destroyed. No. 2 gun has been removed, and may have been damaged in an earlier raid. Nos. 1 and 3 guns are probably still in position, with four near misses within 30 yards.

Air Cover: Sortie US 13/75 of 21 May 1944. Photo Nos. 5002-3.

Comment:

This position will probably be abandoned.

2. CURSEL FARM.

Reference Map: G.S.G.S. 4250/321/567452.

In a recent raid on this four gun medium howitzer position, No. 1 emplacement was slightly damaged by a near miss. All four emplacements are occupied.

A number of hits were scored on roads and wire in the area. The Command Post and three shelters were reported demolished in an earlier raid.

Air Cover: Sortie US 109/326 of 24 May 1944. Photo Nos. 5010-2.

3. MOIT FLEURY.

Reference Map: G.S.G.S. 4250/725/918861.

This four gun medium battery was bombed on 23 May. No new craters are seen within 100 yards of the four casemates. Nos. 1 and 2 casemates are now complete. Nos. 3 and 4 have walls up, but some work still remains to be done on the interior.

Air Cover: Sortie 140/173 of 24 May 1944. Photo Nos. 4033-6.

B. OTHER REPORTS.1. GRISCH-FOURWAY.

Reference Map: G.S.G.S. 4250/626/517906.

A new four-gun battery is seen in a row of trees which line a road. The guns are pinpointed at 51779067, 51739061, 51689053, and 51669048. Only the forward edge of the emplacements are visible, the remainder being concealed by trees. No minor defenses or wire have been installed as yet.

Air Cover: Sortie 15/75 of 24 May 1944. Photo Nos. 5005-6

Comment: Probably a field troop.

TOP SECRET  
BIGOT

/2. LES SEIS.....

0052

TOP SECRET  
BIGOT

- 2 -

2. LES SEUR.

Reference Map: G.S.G.S. 4250/6E1/304273.

All four emplacements of this medium howitzer battery are occupied.

Air Cover: Sortie 16/244  
of 22 May.Photo Nos. 3019, 4022.3. GENERALMONT. LE MARTEL.

Reference Map: G.S.G.S. 4250/7E4 &amp; 6E3/504250.

All six emplacements of this heavy AA battery are occupied.

Air Cover: Sortie 106G/427  
of 19 May 1944.Photo Nos. 3031-2.4. PORT ST. ANDREOUE.

Reference Map: G.S.G.S. 4250/7E4 &amp; 6E3/478285.

Nos. 1, 3 and 4 casemates, measuring 25 feet by 30 feet, are now complete. No.2. is nearing completion. Centre line of battery is South West. A possible CP or CP is under construction on the South-West corner of the Port, in front of No.2. casemate.

Air Cover: Sortie 106G/437  
of 20 May.Photo No. 4107.5. LES ARRES.

Reference Map: G.S.G.S. 4250/6E1/320291.

A completed casemate, 36 feet by 22 feet, is seen here. The casemate may be occupied. Centre line is North East. A second casemate is in early stages of construction 96 yards, with probable centre line North West. Hedges and brush have been cleared between the casemates and the shore.

Air Cover: Sortie 106G/440  
of 20 May 1944.  
Sortie 16/244  
of 22 May 1944.Photo Nos. 4003-4.

" " 4019, 4021.

Comment: Probably a light coast battery.G-2 (Intelligence) Division,  
SHLEP.  
28 May 1944.TOP SECRET  
BIGOT

0053

BIGOT

TOP SECRET

APPENDIX 'E' TO NEPTUNE AREA NO. 33  
 Dated 28 May 1944

Obstacles in the NEPTUNE Area

Underwater Obstacles

1. HABLE DE NEPTON Reference Map: S. S. G. S. 4490/83.

A double row of obstacles, probably stakes, is now seen in front of the mine previously reported in this area (see attached tracing). The average spacing is 100 feet between stakes and 80-90 feet between rows.

Owing to the large number of amendments which have been issued since the tracings of this map sheet in NEPTUNE AREA NO. 3, it has been decided to issue fresh tracings of this map sheet to clarify the situation.

Air Cover: Sortie 1066/518 Photo Nos: 4002, 3002  
 of 27 May 1944

2. COURT BILLES-NEPTUNE Reference Map: S. S. G. S. 4490/84.

Between 978360 and 980859 an area of beach about 300 yards deep is covered with numerous small objects near the water's edge. It is probable that the objects are jetsam washed up by the storm of 23/24 May.

At 971856 and 967355 the rows of hedgehogs are being broken up and formed into a scattered belt, as in other areas previously reported.

Air Cover: Sortie 1066/517 Photo Nos: 4019-21  
 of 27 May 1944

3. POINTE DU GROUIN to BARRAGE DE SALINIER Reference Map: S. S. G. S. 4490/85 & 87

The dark line reported in last night's NEPTUNE AREA NO. 33 is seen again on the latest cover.

Seven stake-like objects are seen at 49259125 and four more at 49459094.

Groups of thin stakes, probably for fishing purposes, are seen at 48658996, 48778967 and 49178896.

There have been no other additions to underwater obstacles in this area, but three beached tank landing craft at 48939033, 48999038 and 48928975 are clearly being used for the transport of underwater obstacles, and further developments in this area may be expected.

Air Cover: Sortie 1066/521 Photo Nos: 4001 - 7  
 of 27 May 1944.

G-2 (Intelligence) Division,  
 SLEP.  
 28 May 1944.

9574

TOP SECRET  
 BIGOT

0054

Issued with Appendix III to MEMORANDUM No: 31 dated 28 May 1944.  
 Same date, sheet 89. This tracing will be used for (Map)  
 This tracing supersedes all previous traces & tracings of this  
 map sheet.

TOP SECRET

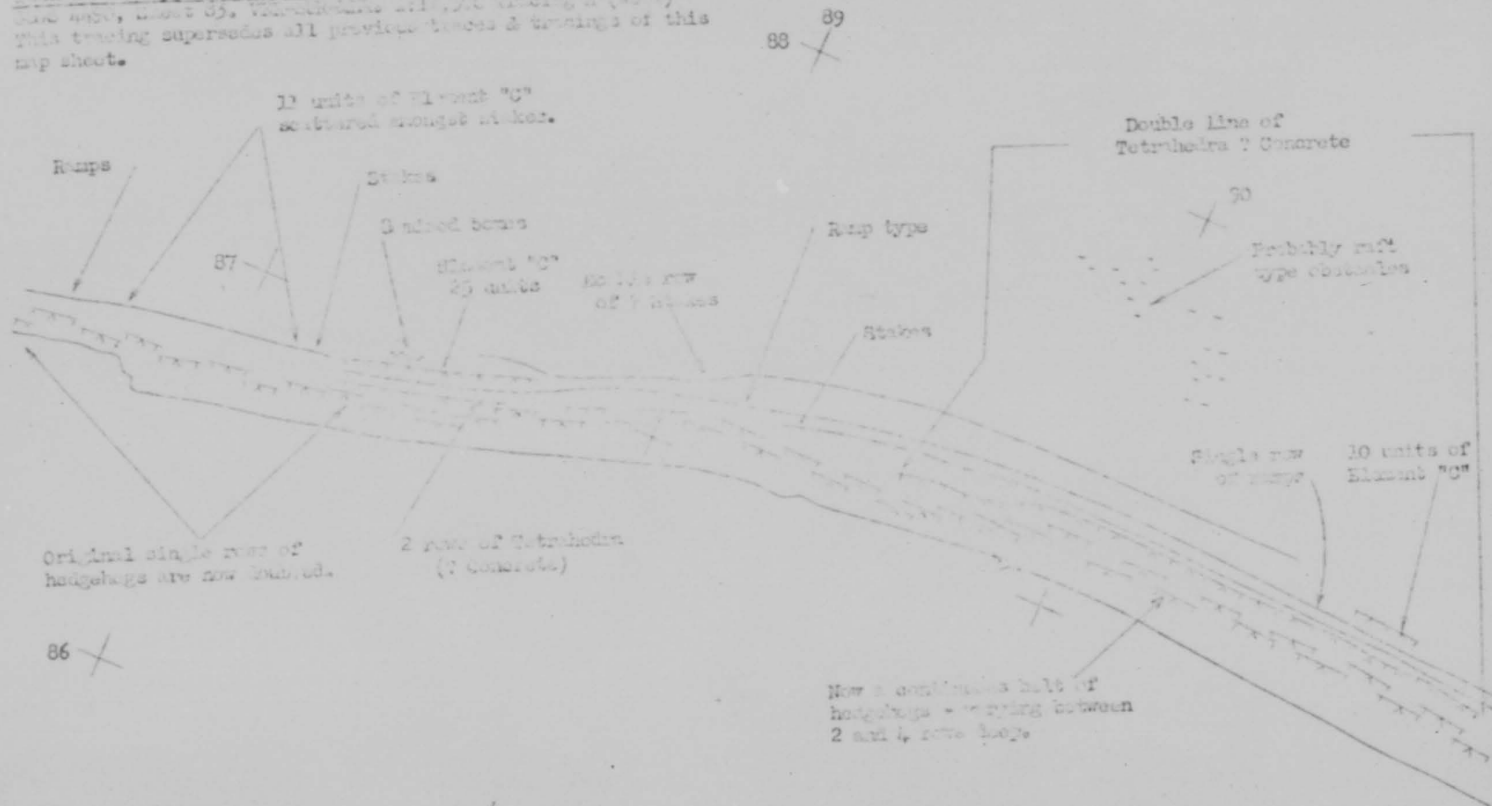

TOP SECRET

BIGOT

G-2 (Intelligence) Division,  
 SMCY.  
 20 May 1944

89

0055

0-2 (Intelligence) ~~TOP SECRET~~  
20 Nov, 1944.  
**BIGOT**

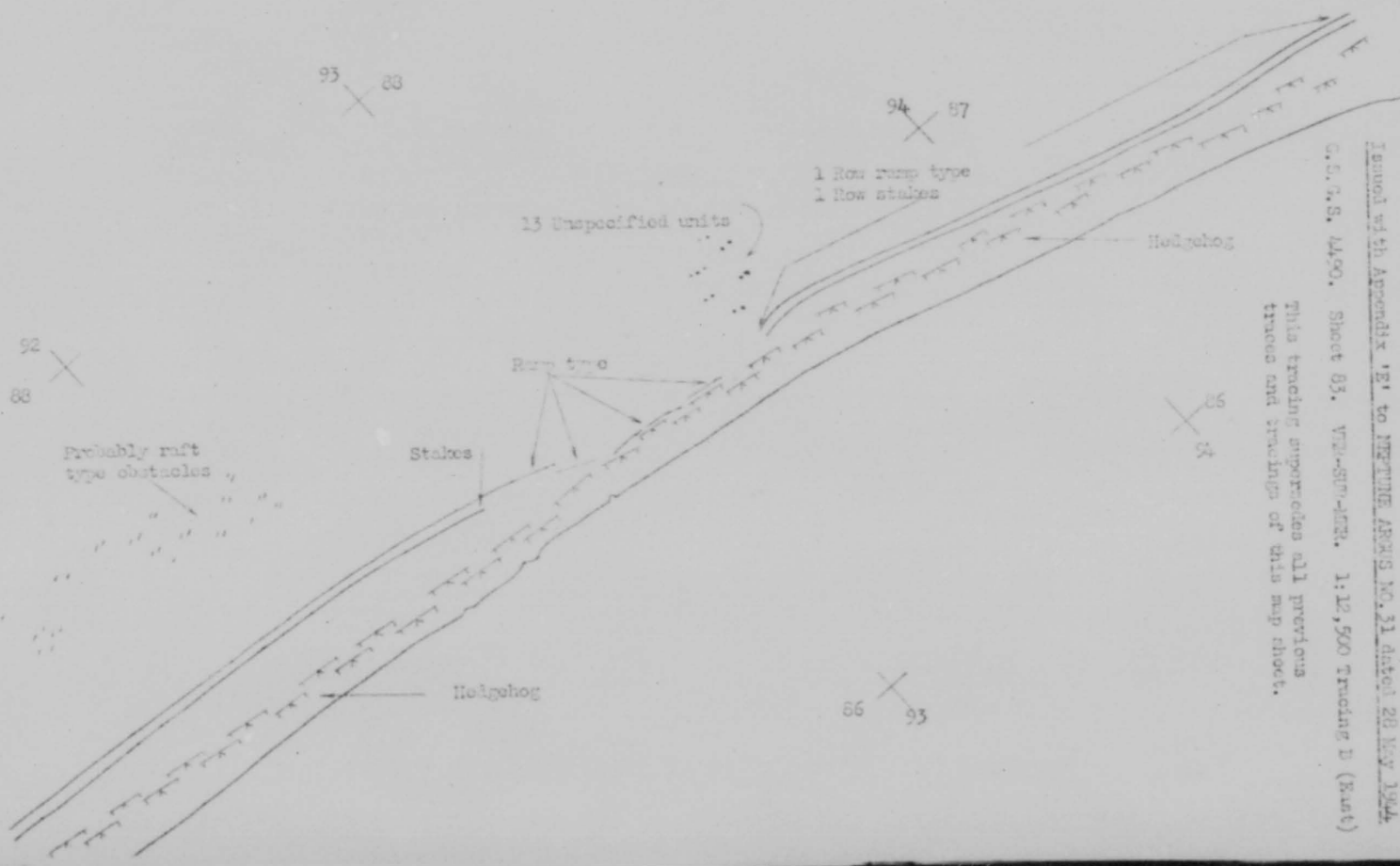

**TOP SECRET**  
**BIGOT**

Issued with Appendix 'E' to REFERENCE AREA NO. 31 dated 28 Nov 1944.  
G.S. O.S. 44/90. Sheet 83. VTB-800-100. 1:12,500 Tracing D (Barb)  
This tracing supersedes all previous  
traces and tracings of this map sheet.

**TOP SECRET**

0056



## BIGOT

TOP SECRET.

APPENDIX 'I' TO NEPTUNE ARGUS NO. 21  
Dated 26 May 1944.

Signal InstallationsA. Results of attacks on enemy radar stations up to 24 May 1944.

<u>Place</u>	<u>Map Reference</u>	<u>Damage</u>
1. COTTREY/DE HAN	4040/20-732081	"Chimney" destroyed.
2. CAP BLANC HUE	4040/38-772759	Westerly Giant Wuarzburg destroyed.
3. LE TRAPORT/MONT HUON	4250/905-442813	2 probable hits on Giant Wuarzburg.
4. DIEPHE/CAURICOTE	4250/905-208675	Strikes on Hoarding.
5. ST. VALERY EN CAUX	4250/806-392538	Cannon strikes on one Giant Wuarzburg.
6. CAP D'ANTIFER	4250/821-516467	"Chimney" unserviceable for considerable period.
	-517473	Direct hit on one Giant Wuarzburg.
7. CAEN/DOUVRES LA BELLEVILLE	4250/735-006808	"Chimney" believed unserviceable but not destroyed.
8. ARUNDANES	4250/735-354365	Possible hits on Coast Watcher and near misses on Giant Wuarzburg.
9. CERBOURG/THOUVILLE	4250/621-254257	Probable hits on both Giant Wuarzburgs.

B. Results of attacks on Navigational Bona Installations up to 24 May 1944.

<u>Place</u>	<u>Map Reference</u>	<u>Damage</u>
1. SORTOVILLE - EN BELANGNY	4250/516/066987	"Knickboin" destroyed.
2. LAMBER	4250/378/535293	"Knickboin" destroyed.

G-2 (Intelligence) Division,  
SECRET.  
 26 May 1944

9526

TOP SECRET  
 BIGOT

7 7 4 0  
 0 0 5 7



BIGOT

TIS/06/132/A

SUPREME HEADQUARTERS  
 ALLIED EXPEDITIONARY FORCE  
 G-2 (INTELLIGENCE) DIVISION

TOP SECRET

COPY NO. 101

22 May 1944

NEPTUNE ARGUS NO. 32

With this Report:-

Appendix 'A' - Artillery

Appendix 'B' - Flak

Appendix 'E' - Obstacles

Raft Obstacles

1. A report of this type of obstacle has been received from a reliable source, who describes rafts seen at AULT (G.S.G.S. 4250/904/5185) on 25 April 1944. His description agrees closely with Photo No. 0047 of sortie U.S. 30/4000 of 19 May 1944, which was issued with NEPTUNE ARGUS NO. 24. (See sketch below)



The source reports that 6 round mines, 40cm in diameter - these are presumably Teller-mines, of which the actual diameter is about 31 - 32 cm - are attached to each raft. It is NOT clear from the sketch to what part of the raft the mines are attached, but it is possible that they will be attached on each side of the three triangular bands which appear in the photograph. There is NO trace of mines in the photograph, but it seems reasonable to suppose that, as in the case of stakes and ramps, mining is carried out at a later date, and had NOT taken place at the time of the photograph. See NEPTUNE ARGUS NO. 31, paragraph 1 and previous reports.

Concrete-tetrahedra - "ROMMEL-SPERREN".

2. The same source, reporting the use of concrete tetrahedra as underwater obstacles at AULT, gives a description very similar to that given in NEPTUNE ARGUS No. 28, paragraph 5 but gives the length of the component parts as 1.65 metres (5 ft 5 inches) as opposed to 2.2 metres, in the BAYONNE report. He states that the elements are bound together by steel bands; an accompanying sketch shows holes at the ends of the elements which did NOT appear on the sketch of the BAYONNE tetrahedra. Source indicates that concrete tetrahedra are known as "ROMMEL Obstacles" (Rommelsperren).

Wiring of Underwater Obstacles

3. A ground source reports that in the MEDITERRANEAN, (where tide-range is very small), hedgehogs are driven in below low water mark by means of a floating crane. Later they are joined together with cables by divers. Barbed wire is also used between the obstacles.

TOP SECRET  
 BIGOT

/Comment.....

0058

BIGOT

- 2 -

Comment:

Extensive wiring of underwater obstacles in the PAS DE SOISSON Area was reported in REFERENCE ARGUS No. 31, paragraph 6. Little wire has been reported in the REPTURE Area.

Flooding in the Valley of River LA SARTHE.

Reference Map G. S. S. 4347 1/25,000 Sheet 37/18 S.E.

4. Sortie 106 G/317 of 27 May 1944 (Notes 3006, 3007) shows flooding in the Valley of the River LA SARTHE for a stretch of about 1,000 yards upstream, down 2 bridges on the outskirts of COMMUNES-SUR-ROSE at 961846 and 964845 to approximately 960837 and 958856.

The river, which here runs in two main channels, seems to be dammed at the two bridges (961846 and 964845). The flooding ranges from heavy saturation to sheet flooding, estimated to be from 6 to 9 inches deep.

Activity at VILLAGE-LE-VALAIS.

Reference Map G. S. S. 4260 S.E. 5.

5. Further cover of the VILLAGE-LE-VALAIS area (see REFERENCE ARGUS no. 19, paragraph 4) shows that a small part of the railway station at ST. MARTIN (459225) has probably been camouflaged in a manner similar to that at VILLAGE-VICOT (456007).

A camouflaged installation at 507225 may be an ammunition point adjacent to possible entrances underground. There is a camouflaged loading gantry at 506024.

That underground association does exist in the area may be surmised from the fact that trucks apparently disappear underground at 508019 and 508023.

An overhead cable running from the woods at 504035 to the main road at 516098 makes a slight detour to touch the camouflaged position at 507003.

Little information is available about quarries in the VILLAGE-LE-VALAIS district. All ground references refer to extensive underground workings and numerous caves just south of the village and state that there is great activity going on to render these suitable storage sites. BOTHIN 1926 refers to a quarrying concern in the village; since there is no reference to the quarries in the more recent editions, it is likely that they have been inactive for some time.

Photo Cover: 401159 3033 & 3062 of 25 May 1944.

Gas Bombs at CHEBONNE.

6. A source of unknown reliability reports at second-hand that large stocks of gas filled bombs are being manufactured and stored in the CHEBONNE area.

Comment:

Considered unlikely. This report is as vague as most other reports on chemical warfare. There are no confirmed gas dumps in the area and it is possible that source really means the factory and dump of CHEBONNE/LEZ ENCOUFFE where naval aviation is handled and stored in galleries under the hillside. Ammunition for the secret weapon ("Verwulungswaffen") is sometimes reported in similar terms. Some sort of petroleum warfare device might equally well be meant. /7 .....

TOP SECRET

BIGOT

0059

TOP SECRET  
BIGOTConcrete Boxes and Blocks.

7. Reference paragraph 5 of NEPTUNE ARMS No. 31. Details of the four different types of concrete boxes seen near PORT-SAÏKH (G.S.G.S. 4041/71 57/500037) follow: (See sketch below).

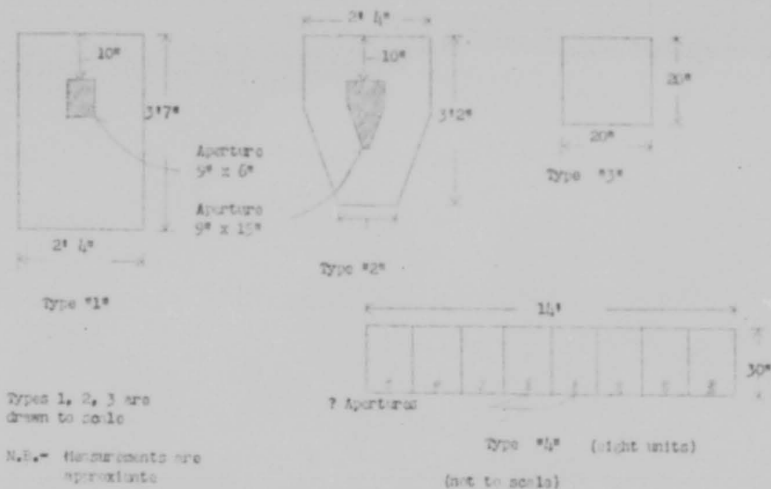

There are 12 examples of type "1", of which two have an aperture similar to that of type "2". There are 13 examples of type "2" and 52 examples of type "3".

Type "4", of which there are five closely packed rows, each of eight units, appears to be similar to type "3", but has a small aperture at one side.

Air Survey: Sertie 16/298      Photo Nos. 5005      These photographs  
of 27 May 1944.      & 5005      accompany this report

Comment:

- (a) Types "1" and "2" are clearly the same as the concrete "boxes" already seen on low oblique photographs on beaches between the MC BRIDE and MAC-CUMBER estuaries. They support a steel rail or wooden post fitted in the socket on top. On the basis of reports from DEBARK, the socket is also supposed to contain a mine, which is detonated when the rail or post is pushed back violently. Although the boxes in DEBARK were said to be iron, this theory still seems plausible. The apertures appear somewhat small to contain mines, but it is possible that the sockets have a lid and are wider inside. It is NOT known how types "1" and "2" differ in use. (CF photo no. 6051 of US 30/4000 of 19 May 1944, issued with NEPTUNE ARMS No. 24).
- (b) Type "3" are probably concrete blocks used to support hedge-hogs and other obstacles; such supports are well-known. There is no reason to associate these blocks with mines. See also section (d) below. (CF photo no. 6068 of US 30/4000 of 19 May 1944, issued with NEPTUNE ARMS No. 24).
- (c) Type "4" has NOT been observed previously. Since these blocks are seen together with blocks known to be used for underwater obstacles it is reasonable to suppose that they will be similarly employed. The possible apertures shown

/on the.....

TOP SECRET  
BIGOT

0060

TOP SECRET  
BIGOT

- 4 -

on the sketch may be to hold anti-tank rolls or a similar device; but see below section (4).

- (4) It is possible that the type "A" blocks are type "3" blocks being on a different level, i.e., both type "1" and type "3" are 30' x 40' x 30" blocks. This possibility is increased by the fact that photographs show type "3" in its present position to have greater length than type "4". The possible explanation seen on type "4" may be similar supports for supporting the ends of adjoining obstacles. There is no evidence for associating either type "3" or type "4" with mines.

Possible Underground Structure near AREA

Reference: A.S. 2. 447. 2. 16. 1. 1.

8. Activity suggesting construction of an underground of large size is seen in the vicinity of the structure shown in sketch. In the quarry area are a number of structural and storage structures; each one with a roadway leading into it.

Little activity is seen in the vicinity of the structures and no H.T. is present in the area. There are a number of structures in the immediate vicinity and defense elements of 4 inch diameter machine gun positions.

Ground indicator is located in it is possible that the SE. LO Corps Headquarters may have an interest in the quarry which may be used as vehicle or general storage depot.

Step Cross

(2) Underway Obstacles Linked by Cable

9. Detailed reconnaissance of recent air cover shows that 3 units of Element 'C' near A.S. 2. 447. 2. 16. 1. 1. (S.S.C.S. 4490/34/016852) appear to be linked by cable. (See paragraph 5 above).

Air Cover: Berlin 16/17  
of 24 May 1944.

Photo No.: 4051-2

Joseph D. Ross  
Major-General,  
A.C. of S.,  
G-2.

TOP SECRET  
BIGOT

0061

## BIGOT

TOP SECRET.

APPENDIX A.1 TO NPTIME ARGUE NO. 32  
PART 1A, 1944.ARTILLERY IN THE NPTIME AREA.I. ROAD DAMAGE.

1. NORMANNES. Reference Map: G.S.G.S. 4250/623 & 4.  
The following is the situation at this six-gun medium battery:  
Four emplacements (Nos. 1, 2, 4 and 5) are unoccupied.  
Nos. 3 and 6 appear to be damaged, but may be occupied.  
No repairs are being made on the site, and bomb craters  
have NOT been filled in.

Air Cover: Sortie: 16/294  
of 27 May 44.

Photo Nos: 4042-3.

2. CHATELLE DE LA VIERGE. Reference Map: G.S.G.S. 4250/821/713556.  
After recent raids, the situation at this battery is as follows:  
No. 5 emplacement is unoccupied, and damaged. No. 6  
is demolished. Nos. 1, 2, 3 and 4 probably occupied.  
Nos. 3 and 4 casemates, which have been completed, and  
may be occupied, are slightly damaged.

Air Cover: Sortie: US 76E/598  
of 27 May 44.

Photo Nos: 4018-9.

3. LONGUES Battery. Reference Map: G.S.G.S. 4347, Sheet 37/18 SU/  
797371.  
Date of Information: 28 May 1944.  
Oblique photographs show a good concentration of bomb craters in  
the target area. Damage to casemates:-

(a) No. 2 Casemate, which was complete, has had its  
SOUTH-WEST corner demolished by a direct hit.  
The EAST side-wall may have been damaged by a  
near miss.

(b) No. 3 Casemate: the EAST side-wall may have  
been damaged by a near miss.

There is extensive damage to minor defences in the battery area.

Air Cover: Sortie: 414/185  
c. 414/186.

4. ....

CONFIDENTIAL

95P/O

TOP SECRET  
BIGOT

0 0 6 2

TOP SECRET  
BIGOT

- 2 -

4. HOULANDE Battery.

Reference Map: G.S.G.S. 4347, Sheet 40/1803

Date of Information: 25 May 1944.

Excellent low oblique photographs show the following situation.

Open Emplacements:

- (a) No. 1 is the only occupied emplacement.
- (b) Nos. 2, 3, 4, 5 have been completely obliterated.

Casemates:

- (a) Nos. 1 and 2 are incomplete and do NOT appear to be damaged.
- (b) Nos. 3 and 4 are complete and do NOT appear to be damaged, although a hole has appeared in the roof from the SW side of No. 4, increasing the room area. Both have been covered with strips of sandbags outside, and the roof of No. 3 has also been covered with a thin layer of earth.

Air Cover: Sorties: 414/179 and 414/180.

5. BIVA BELLA Battery.

Reference Map: G.S.G.S. 4347, Sheet 40/16 NW  
117797.

Date of Information: 25 May 1944.

No further damage is seen at this battery. Nos. 1, 3, and 6 open emplacements are unoccupied on this cover.

Air Cover: Sortie: 400/157, 3068-9.

II. ....

TOP SECRET  
BIGOT

0 0 6 3

TOP SECRET  
BIGOT

## II. OTHER REPORTS.

1. HAIR II. Reference Map: G.S.G.S. 4250/626/528916.  
At this four-gun light concrete battery, No. 1 concrete is almost complete, No. 2 well advanced, but still surrounded by scaffolding, and Nos. 3 and 4 are complete. Spoil has NOT been removed from the site.  
Air Cover: Sertic: 1066/429 of 19 May 44. Photo Nos: 4044-5.  
Comment:  
The four guns of this battery are still in the open at 531914.
2. COLLEVILLE-SEA-SEA. Reference Map: G.S.G.S. 4250/771/076782.  
At this four-gun light battery, concretes Nos. 1, 3 and 4 are complete, and No. 2 is nearly complete, with scaffolding and constructional material still on site. Spoil has NOT yet been removed. At the dummy position (069732), No. 3 emplacement has been removed, and three dummy concretes have been built forward of Nos. 1 and 2 "guns" since 12 May.  
Air Cover: Sertic: 1066/429 of 19 May 44. Photo Nos: 3003-4.  
Sertic: 400/157 of 25 May 44. Photo Nos: 4125-6.
3. HOVE FLINDY. Reference Map: G.S.G.S. 4250/725/918861.  
No. 1 gun has been removed from the concrete and is now back in the hedge at 916859 with the other guns. Three guns and a probable fourth can be identified on this cover.  
Air Cover: Sertic: 1066/543 of 27 May 44. Photo Nos: 3003-4.
4. TRIMBLEVILLE. Reference Map: G.S.G.S. 4250/725/992826.  
Forward of the "problem" battery at 994819 are two parallel trenches 70 yards long, 30 feet across, running roughly SOUTH-EAST - NORTH-WEST. In the bottom of each is what appears to be an outside drain pipe. Both trenches have filled in sections 12 feet long alternating with unfilled sections 12 feet long. The purpose of this installation is NOT known.  
Air Cover: Sertic: 4/111 of 27 May 44. Photo Nos: 3005-6.  
Comment:  
It is NOT certain that this installation has any connection with the "problem" battery.
5. COLLEVILLE-SEA-SEA. Reference Map: G.S.G.S. 4250/735/923815.  
Three camouflaged positions visible at edge of a small patch of scrub. A track links these positions with the road to the rear. Centre line roughly NORTH. It is NOT possible to state whether these positions are occupied.  
Air Cover: Sertic: 1066/573 of 27 May 44. Photo Nos: 3009-10.  
Comment:  
The positions appear too small to be occupied by anything but light guns, possibly infantry weapons.

CONFIDENTIAL TOP SECRET  
BIGOT  
93P10

/6.....

0064



TOP SECRET  
BIGOT6. COLLEVILLE-SUE-GENE.Reference Map: G.S.G.S. 4347. Sheet No.  
40/16 NW, 076783.Date of Information: 25 May 1944.

Nos. 1, 3, and 4 casemates are complete. No. 2 casemate is ready for the roof to be put on.

Air Cover: Sortie: 400/157, 3153-4.7. DEWILLE.Reference Map: G.S.G.S. 4347. Sheet No.  
40/16 NW, 059745.

Four partly prepared emplacements along South edge of field. There is little sign of activity. Diameter of emplacements, 20 ft. distance apart, about 50 yds.

Air Cover: Sortie: 400/157, 5224-4.8. QUINCYHAM Battery.Reference Map: G.S.G.S. 4347. Sheet No.  
40/16 NW, 103794.

Another dummy casemate is being built. It is in front of No. 3 "gun" in this dummy battery.

Air Cover: Sortie: 400/157, 4072-3.9. REVINES.Reference Map: G.S.G.S. 4347. Sheet No.  
37/18 SE, 977808.Date of Information: 27 May 1944.

What appears to be genuine track activity is seen at this dummy battery, which is associated with KNELDHAM Battery 972808. The "guns" do NOT appear to have changed, however.

Air Cover: Sortie: 106 G 549, 4119-40.10. LA FOSSE Battery.Reference Map: G.S.G.S. 4347. Sheet No.  
31/20 NE, 358138.Date of Information: 27 May 1944.

All four casemates are now complete. Wooden shuttering has been removed.

Air Cover: Sortie: 16/294, 3037-8.11. CHERBOURG Railway Gun Battery.Reference Map: G.S.G.S. 4347. Sheet No.  
31/22 SE, 124246.Date of Information: 26 May 1944.

No. 3 Turntable is definitely unserviceable.

Air Cover: Sortie: 16/287, 3085-6.12. BAUNDEWILLE.Reference Map: G.S.G.S. 4347. Sheet No.  
31/22 SE, 115239.Date of Information: 26 May 1944.

Guns are seen in five of the open emplacements. The four casemates are now complete. No. 5 gun has been moved clear of the casemate which formerly masked it.

Air Cover: Sortie: 16/287, 3085-6.TOP SECRET  
BIGOT

13. ....

0065

- 5 -

13. THYVILLE.

Reference Map: G.S.G.S. 4347. Sheet No.  
31/22 34, 260248.

Date of Information: 24 May 1944.

Four-gun position, probably light field guns, in a hedgerow. Diameter of emplacements: 22 feet. Distance apart: (right to left) 125 feet - 135 feet - 157 feet. Possible command post in hedge south of gun position and about 475 feet from it. Around each gun-emplacement there are a number of small pits.

Air Cover: Sortie: 16/244, 4051-2.

G-2 (Intelligence) Division,  
SHAEP.  
29 May 1944.

0 0 6 6

TOP SECRET  
BIGOT

TOP SECRET

APPENDIX 'B' TO NATURE ARGUS NO. 32  
Dated 29 May 1944.

## PEARL HARBOR DEFENSE AREA

A. From Air Photographs

EVANS (4250/58/3) 250840	3 lt.	US. 31/414 19 May 1944
HAUNTS-CORNER (4250/58/4) 629000	4 hy, 2 lt and SL, 2 y/c	140/100 4058-9
612600	3 SL w/c	4063 - 4
605500	4 hy, 2 lt w/c	3059 - 60
576605	4 hy unplaced, 2 lt u.	3065
VIRION (4250/58/4) 422700	3 lt in Strongpoint	4104 - 5
455705	3 lt and SL w/c.	3098 - 9
LA ROCHER (4250/58/4) 507700	3 lt	4119 - 21 8 May 1944
507714	1 lt SL	
507717	1 lt	
505701	2 lt and 1 lt SL	
507719	Possible SL	
501720	1 lt	
501721	1 AA M.G.	
CHATHAM (4250/58/4) 407010	SL now u.	US. 34/321 8 May 1944
PRETHILL (4250/58/6) 665300	3 lt	US. 34/321 8 May 1944
659506	3 lt now u.	
GAIN (4250/58/1) 052670	2 lt now 3 lt.	414/130 19 May 1944
ST PETERS-BAY-DIVES (4250/71/4) 214300	4 hy u.	414/131 19 May 44
ALLIANCE (4250/71/4) 214300	3 lt u.	140/101 3124 - 5 8 May 1944
GRAVE (4250/62/5) 120355	Possible 2 lt u.	16/150 4085 - 9 8 May 1944
122346	S.L.	
128345	3 lt u.	
126342	4 hy abandoned	
117332	3 lt and 1 lt SL.	
BEAUMONT-MARIE (4250/51/2) 115429	4 hy now 3 u.	400/124 19 May 1944

95010

TOP SECRET  
BIGOT

/REMARKS .....

0067

TOP SECRET  
BIGOT  
- 2 -

HERMES (4040/75 SE)		
967515	6 hy u now 6 hy 2 u	1060/844 18 May, 1944
971505	3 lt	
972479	3 lt	
973479	Possible 1t S.I.	
037526	3 lt now occupied	
041534	3 lt now occupied	
045527	3 lt now all occupied	US. 7/1511 23 May 1944
054526	3 lt u.	
024573	4 hy now u.	
022573	6 hy making 10 hy, 4 u, in this area.	
948488	Delete 4 hy u.	US. 7/1515 23 May 1944
962558	6 hy, 3 lt.	140/79
018527	3 or 4 lt rly Flak.	3264 - 70
022529	1 lt.	
077601	2 lt Flak towers u	4250 - 3
079597	" " " " "	3 May 1944
069597	" " " " "	
977553	3 lt.	140/121
968533	3 lt u.	4006 - 9
057502	4 hy	4023
058498	6 hy	
057499	Hy S.I.	11 May 1944

B. From Other Sources

DREUX (4041/201NW) Date of Information April 44.

Flak in the neighbourhood of DREUX is reported to consist of four 105mm eight 88mm and eight 20-30mm guns.

Comment:

(a) Sortie 140/61 of 27 April, 1944 shows at 332361 six empty emplacements probably suitable for 105mm AA guns. There are three or four weapon pits and a number of ammunition shelters nearby. On air-cover of 19 April (RB 659, 3159-40) the site appears occupied. Five of the positions are tented over probably with camouflage netting. Three light AA guns are also visible on the site. Later cover, dated 27 April, shows the position again unoccupied.

(b) At 343323 are three occupied light AA emplacements which appear fairly new. Nearby on either side of the road are four M.T. bays. At 344321 are two AA M.G. positions (RB 659, 19 April 44).

(c) Two light AA positions, as yet unoccupied, have recently been built at 353318. At 354316 and 312352 are two 4-gun heavy positions. (RB 659, 19 April 44).

ALENCON (4250/70/4) Date of Information 30 Jan 44.

A crudely sketched town-plan of ALENCON just received shows what it describes as four 77mm AA guns and three AA M.Gs West of the town at about 326837, South of the ROUTE-NATIONALE.

Comment:

No Flak can be seen at the point indicated by source, but North of the ROUTE-NATIONALE at 322841 there are two occupied AA emplacements 10ft by 25 ft, each containing what may be a light self-propelled AA gun. Tracks leading in to the emplacements

TOP SECRET  
BIGOT

/are clearly.....

0 0 6 8

TOP SECRET  
BIGOT

- 3 -

are clearly visible. Further North, at 824545 and 825851 respectively are three occupied and one unoccupied emplacements with similar characteristics.

Air Cover. Sortie RB 424, 17 March, 1944.

LISIMUX (4250/88/1) Date of Information 3 April 44.

The Flak which was specially deployed in the neighbourhood of LISIMUX to protect the untraiement of 10 SS Panzer Division has now gone.

Comment:

Confirmed. At LISIMUX there are now only about 6 light AA guns.

VOVES (4250/90/6) Date of Information 16 April 44.

Nineteen waggons mounting 4-burrelled AA guns are reported to arrive every evening about 2000 hours, at VOVES Station, where they spend the night.

Comment:

VOVES is believed to be a light railway Flak depot.

DIGARD (4347/31/225W) Date of Information 24 May, 44.

A 3-gun light Flak position has been constructed at 109251 South of the already reported light flak position at 109213, now unoccupied. The gun emplacements are at 10952113, 10952110 and 10952108.

Air Cover 16/266, 24 May 44.

REGRES (40408/758E) Date of Information 5 April 44.

A good source reports that, at the date of information, there were some 20 light railway flak waggons and a 4-gun heavy railway flak battery in sidings at REGRES Station.

Comment:

The presence here of 20 light railway flak waggons is NOT remarkable: REGRES is known to be a light railway flak depot. The heavy guns, present on the 5th, had left by the 30th April.

MAISON BLANCHE (40408/758E) Date of Information 21 April 44.

A good source reports a 4-gun AA battery at MAISON BLANCHE, 027577, North of REGRES.

Comment:

Air cover shows one 6-gun and two 4-gun heavy AA batteries here and a 3-gun light AA battery. The house to the South and the village to the East of the gun positions show signs of military occupation.

G-2 (Intelligence) Division,  
SHAEP.

TOP SECRET  
BIGOT

0069

TOP SECRET  
BIGOT

TOP SECRET

APPENDIX 'B' TO NEPTUNE ARGUS NO. 32  
Dated 27 May 1944.Obstacles in the NEPTUNE Areaa. Road Blocks.

1. BAINS DE TOUQUEVILLE Reference Map: GSGS 4347/Sheet 43/18 SW.

Five units of Elements C are seen at 42901195; They are standing end to end along the road parallel to the beach. They may eventually be moved forward to add to the Elements C already in position as underwater obstacles here, or alternatively be moved East or West to block the sidestreet leading inland, which appear to be unobstructed at present.

Air Cover: Sortie 140/157 of Photo Nos: 4044-45  
22 May 1944

2. HOULGATE Reference Map: GSGS 4347/Sheet 40/18 SE.

Roads entering the built-up area from the South are blocked at 24798057, 24768043, and 24328043.

Air Cover: Sortie 16/259 Date of Information: 24 May 1944

3. EVREUX Reference Map: GSGS 4250/9F/3

All the roads into the town have been blocked with chevaux de frise, wire and metal obstacles, probably hedgehogs.

Air Cover: None Date of Information: 4 May 1944.

b. Ditches.

1. FRANCEVILLE PLAGE - CABOURG Reference Map: GSGS 4347/Sheet 40/16 NE.

Air photographs, show additions to the section of anti-tank ditch running South of the main coastal road FRANCEVILLE PLAGE - CABOURG, as follows:-

18537905 - extension of 400 feet.  
19007900 - extension of 200 feet, and  
20107398 - 20357900 - new stretch under construction. Immediately North of the line of the ditch, the road is blocked at 18887913, 18907935, 20207904, 20307915, 20377960.

Air Cover: Sortie 16/259, of Photo Nos: 4025-6 & 4021-2  
27 May 1944

Date of Information: 27 May 1944

Comment:

A ground source reports that between SALLENELLES (1377) and CABOURG almost all the houses along the main road have been demolished in connection with the construction of this ditch, and that similar work is in progress at HOULGATE (2481).

c. Underwater Obstacles.

1. ASNELLES-VALE DE NEBERTOT Reference Map: GSGS 4490/83

Reference the rafts reported on a tracing issued with NEPTUNE ARGUS No. 30 and commented on in paragraph 1 of NEPTUNE ARGUS No. 31. It is considered after a more detailed examination of the photographs that where  
/two dots .....

75210 TOP SECRET  
BIGOT

0070

TOP SECRET  
BIGOT

- 2 -

two dots occur close together they constitute one obstacle only, the one dot being the raft itself, the other dot being the group of blocks to which it is moored. It is NOT possible on this cover to see the moorings in every case. The total number of rafts is believed to be 14 in the Western and 17 in the Eastern group.

Air Cover: Sortie US 34/451      Photo nos. 5017-3  
of 24 May 1944.

2. HAVRE DE RUSTPAIL      Reference Map: GSGS 4347/26/18 NE & SE

Single rows of possible Element 'C' runs from 04000036 to 04278981 and from 04578997 to 04608990.

(Report received from First U.S. Army, based on sortie US 30/4017 of 24 May 1944, NOT received at T.I.S.).

3. FRANCEVILLE-PLACE      Reference Map: GSGS 4347/40/16 NE & NW

A long belt of stakes, up to 12 rows deep and about 200 yards in depth, intermingled with occasional rows of staggered ramps runs from 151795 to 159796.

A large group of stakes approximately 400 feet square is seen on the seaward side of previously reported Element 'C' at 155797.

The front line of hedgehogs from 151795 to 155795 and from 159795 to 165795 has been broken up and relaid in staggered formations.

Obstacles between 157794 and 161794, hitherto unidentified, are now seen to be concrete tetrahedra.

Air Cover: Sortie 106 G/556  
of 28 May 1944.

4. ST VAUST-LA-ROUËLE      Reference Map: GSGS 4490/70

Good cover of 27 May shows that there is NO Element 'C' amongst the recently laid belt of stakes, as was previously reported (See attached tracing).

Air Cover: Sortie 16/294  
of 27 May 1944.

G-2 (INTELLIGENCE) DIVISION  
SIB:PF  
29 May 1944.

TOP SECRET  
BIGOT

0071



TOP SECRET  
BIGOT

SECRET THIS APPROXIMATE POSITION AND IS NOT TO BE REPRODUCED

SECRET

U.S.S.R. MAP Sheet 13-50-22-10-11-112,500

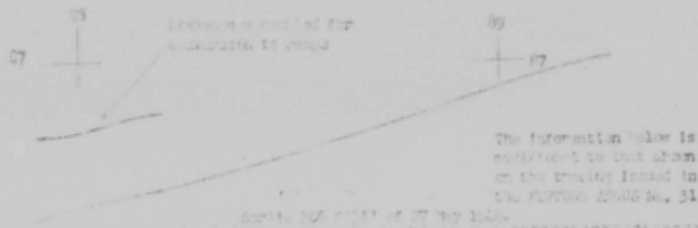

U.S.S.R. MAP Sheet 13-50-22-10-11-112,500

The information below is... that shown on the tracing located in the NEPTUN... No. 31

Article 16/294 of 27 Nov 1944.

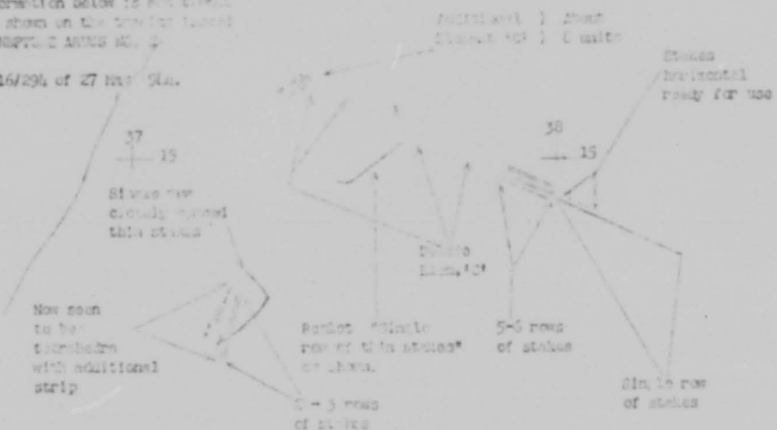

U.S.S.R. MAP Sheet 13-50-22-10-11-112,500

The information below is... that shown on the tracing located in the NEPTUN... No. 31

Article 16/294 of 27 Nov 1944.

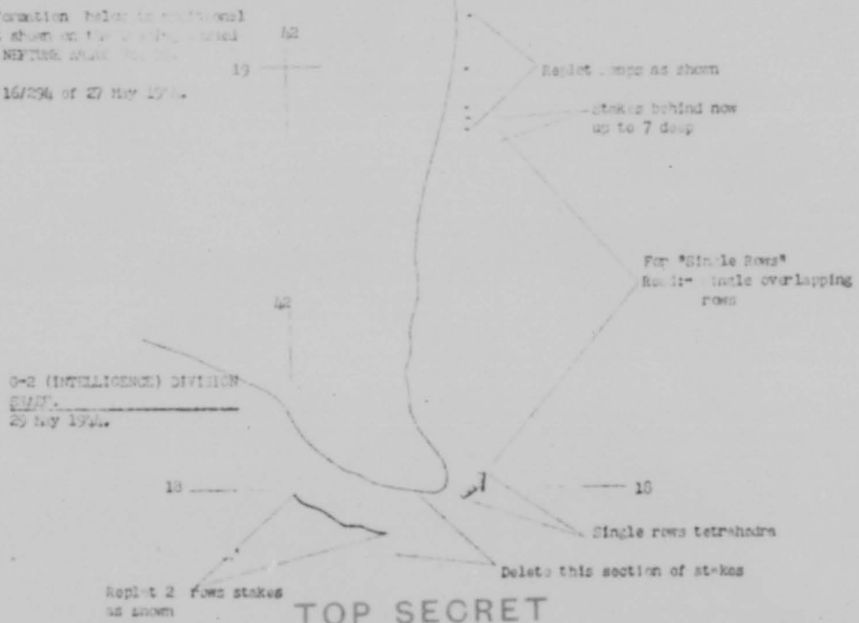

0-2 (INTELLIGENCE) DIVISION  
SMT  
25 Nov 1944.

TOP SECRET  
BIGOT

0072

TOP SECRET  
BIGOT

ISSUED WITH  
NEPTUNE ARGUS  
No 32

CONFIDENTIAL

EXTRACTED  
AUTH: LTR QUARTER BY JCR 46 44 880 01-1 001-100  
SOURCE: JSC HQ 001, 95P10

0073



0074



0075

TOP SECRET  
BIGOT

TIS/00/133/1.

DEFENSE HEADQUARTERS  
JULIED EXPEDITIONARY FORCE  
G-2 (INTELLIGENCE) DIVISION.

TOP SECRET.

COPY NO 101

30 May 1954.

NEPTUNE ARGUS NO. 33

With this Report :-

Appendix 'A' - Artillery

Appendix 'C' - Minor Defences

Appendix 'E' - Obstacles

Appendix 'G' - Ammunition Drops

Inundations in NEPTUNE AREA.Reference MAPS: C.S.C.S. 2738, 1/250,000,  
Sheets 3A & 8.  
C.S.C.S. 4250, 1/250,000,  
Sheets 623 & 4, 625, 522 &  
621, 626, 622.

1. The attached photographs from Series US 34/480, 1/56,000; US 34/497, 1/54,000; and US 34/496, 1/56,000, show the state on 27 May 1954 of the following flooded or floodable areas :-

- (i) River SERRIS, Photo 7002, US 34/480.
- (ii) River SERRIS and flooding at GRADICOP, Photos 7013-14, US 34/480.
- (iii) Behind the beaches on the EAST Coast of COYENNE, including the River SAIRE and the area surrounding the GRAND VIE Estuary, Photos 7004, 7007, 7009, 7011, US 34/480.
- (iv) Rivers DOUVE and VERBERT, and PRAIRIES MARCHEMEURES DE SCHERS, Photos 7005, 7008, 7012, US 34/497.
- (v) Rivers TAVIE and VIE and Canal VIE ET TAVIE, Photos 7003, 7004, 7006, 7008, US 34/497.

Construction of Shell Holes in the NEPTUNE AREA.

2. A number of shell pits have been seen on air photographs, the purpose of which is NOT clear, as they do NOT appear to be normal weapon pits, nor to be sited tactically. They are all between three and five feet in diameter and empty. There are two groups of them near GEPOISE-POYENAY, at 50408670 (C.S.C.S. 4347, 31-18 III) and at 50409110 (C.S.C.S. 4347, 31-18 III) and another group SOUTH of VERBERTS at 364129 (C.S.C.S. 4347, 31-20 III).

Series: 1066/521 of 27 May 54, 4006/7.  
US 15/75 of 24 May 54, 5008/9.  
1066/556 of 28 May 54, 3006/7.

Similar pits have been sited on both sides of river roads inland from DIEPPE. In this area they are in the fields some ten to twenty yards from the road; currently they are grouped in threes, two on one side of the road and one on the other. The purpose of these pits has NOT been explained, but it may be noted that they tend to occur along roads on the outskirts of certain villages.

/Current.....

95P/0 TOP SECRET

0076





TOP SECRET  
BIGOT

-5-

alterations and the relaying of many obstacles SOUTH of QUINEVILLE. There is still no indication of systematic wiring of obstacles on the EWY DOG beaches, but it is reasonable to expect that this will take place soon.

(c) New type of raft-obstacle.

6. Latest air cover of the beaches on the ALSA side of the COUWEN shows an unidentified object on the DUNE DE QUINEVILLE at 41900462 (G.S.G.S. 4490/70). The object in question is rectangular in plan with a blunt triangular "nose" facing seaward. It measures about 15 feet by 7½ feet and appears to have little height. It may be built of small rectangular sections. It is sited immediately to the shoreward of the nearest row of hedgehogs and appears to be wired to the nearest hedgehogs.

CORRECTIONS.

1. HEADING ABOVE NO. 34.

Page 2, paragraph 3. Comment, line 1. For "R.S DE SCHE" read "SCHE".

2. Reference Appendix 'C' issued with this report, paragraph 14, now reference should read 19007250.

*T. S. Cornte*  
Capt.  
for Major General,  
C. of S,  
C. 2.

TOP SECRET  
BIGOT

0078



APPENDIX 'A' TO NEPTUNE ARGUS  
 Dates 16/3/44

TOP SECRET  
 BIGOT

Artillery in the NEPTUNE Area

A. Bomb Damage

1. ST. MARTIN DE VAREVILLE

Ref. Map: GSGS 4250 Sheet 6E/5  
 40580

Date of Information: 29 May 44

The state of this battery following a recent bombing attack is as follows.

A very heavy concentration of craters is seen in the target area, with excellent results.

a. Damage to primary weapons and emplacements:-

- No.1:- one hit on rear edge of emplacement, which is unoccupied and filled with spoil.  
 Nos.2,3 & 4:- cannot be identified amidst a great concentration of craters, and seem to have been destroyed.

b. Damage to casemates:-

- No.1:- five very near misses all within 45 feet - concrete walls damaged  
 No.2:- damaged by at least five near misses.  
 No.3:- destroyed and no longer identifiable; six near misses.  
 No.4:- excavation undamaged.

c. Damage to Command Post.

Demolished by a direct hit and 5 near misses or probable hits.

d. Damage to Communications:-

All roads serving the battery have been cut by a number of direct hits.

e. Damage to Accommodation:-

Personnel shelters in rear of each emplacement all indistinguishable amidst the craters.

f. Number of near misses within 50 yards of each primary weapon:-

Emplacements No.1-17; No.2-13; No.3-15; No.4-11.  
 Casemates No.1-21; No.2-12; No.3-12; No.4-6.

g. Battery local defences have sustained considerable damage, the most noteworthy being the large number of craters (24) in the anti-tank ditch. (Sortie 1060/584. 3062).

2. LONGUES

Ref. Map: GSGS 4347 Sheet 57/18 SE  
 797871

Date of Information: 26 May 44

Vertical photographs confirm the damage reported in Appendix A to NEPTUNE ARGUS No. 32, and show in addition a small crater on the roof of No. 1 casemate, evidently caused by a direct hit which did NOT penetrate the concrete.

Air Cover: Sortie 16/313, 4045-7.

/B. Other Reports....

TOP SECRET  
 BIGOT

0 0 7 9

TOP SECRET  
BIGOTB. Other Reports1. VER-sur-MERRef. Map: GSGS 4347 Sheet 37/18  
SE 900857

Date of Information: 29 May 44

A dummy casemate battery is being constructed. Two "casemates" have been completed already. This position is presumably associated with the genuine battery VER sur MER 917044. Sortie: 16/314, 4051-2.

2. GOBINRef. Map: GSGS 4347 Sheet 43/18  
SE 486141

Date of Information: 28 May 44

A possible new battery position. Three gaps have been cut in a hedge, about 55 yards apart. No guns are seen. In an adjacent field there is a weapon pit and three circular marks which might be the beginnings of a 3-gun lt. A.A. position.

Air Cover: Sortie 16/313

Photo Nos. 4101-3

3. HERNEVILLERef. Map: GSGS 4347 Sheet 43/18  
SE 473152

Date of Information: 28 May 44

All four casemates are complete. Nine excavations for shelters are seen in rear of the casemates. They are connected by a deep trench system which may be developed into underground tunnels. The O.P. under construction forward of the casemates is still in the excavation stage.

Air Cover: Sortie 16/313

Photo Nos. 3045-7

4. STE MARIE DU MONTRef. Map: GSGS 4347 Sheet 34/18  
NW 413916

A possible new battery position. Four unoccupied shallow pits are seen in a row of trees. There is very little activity in the area.

Air Cover: Sortie US 31/483

Photo Nos. 1008-9

5. LIEU HARANGRef. Map: GSGS 4347 Sheet 43/18  
SE 471144

Date of Information: 28 May 44

A possible new battery position. Four disturbances of earth are seen in a field, in typical battery lay-out 33 yards apart. Centre line would be NW.

Air Cover: Sortie 16/313

Photo Nos. 3043-5 and 4101

6. ANDERVILLERef. Map: GSGS 4347 Sheet 28/22  
Composite 918322

Date of Information: 29 May 44

No. 1 casemate is now complete.

Air Cover: Sortie 168/200

Photo No. 0002

7. BUCLARDRef. Map: GSGS 4347 Sheet 43/16 NW  
305797

Date of Information: 27 May 44

/Four....

TOP SECRET  
BIGOT

0080

TOP SECRET  
BIGOT

-3-

Four dummy emplacements are now seen, each containing an object. Probably a dummy for BUCHARD 306800, but the first three dummy emplacements were built before BUCHARD.

Air Cover: Sorbis 400/104

8. La LOUPE

Ref. Map: G030 4347  
Sheet 42/16 NW  
303724

Date of Information: 27 May 44

Four open circular emplacements 25 feet in diameter; distance apart (right to left) 150 feet - 150 feet - 100 feet. They appear on heavy photographs to be empty. Centre line NORTH.

Air Cover: Sorbis 400/104, 4019-6

9. VAROIVILLE

Ref. Map: G030 4347  
Sheet 51/22 SE  
305852

Date of Information: 22 May 44

Probable dummy battery on WUMER side of base. Diameter of emplacements: 14 - 15 feet. Diameter of pits: 30 - 20 feet. In a row of emplacements, about 40 small pits arranged in two lines. There is no sign of a genuine battery nearby.

Air Cover: Sorbis 16/244, 3058-9

G-2 (Intelligence) Division,  
SMEP  
30 May 1944.

TOP SECRET  
BIGOT

0081

TOP SECRET  
BIGOT

TOP SECRET.

APPENDIX 'C' TO REFERENCE MAP NO. 33  
Dated 20 May 1944.LIGHT DEFENCES.

1. LE MOLE SUR MER. Reference Map: G.S.G.S. 4347/40-16 NE.  
There is a pillbox at 17157940.  
Air Cover: Sortie: 16/259 Photo Nos: 4028/9.  
of 24 May 44. Date of Information: 24 May 1944.
2. ST. GEORGES de la RIVIERE. Reference Map: G.S.G.S. 4347/28-18 NE.  
The work which has been in progress at 052932 has developed into  
one shelter and a probable fire trench.  
Air Cover: Sortie: 16/260 Photo Nos: 4117/8.  
of 24 May 44. Date of Information: 24 May 1944.
3. LES BOITIERS d'ALLAGE. Reference Map: G.S.G.S. 4347/28-18 NE.  
There is a dug-out under construction at the road junction at  
04559755.  
Air Cover: Sortie: 16/260 Photo Nos: 3127/8.  
of 24 May 44. Date of Information: 24 May 1944.
4. DIVES SUR MER. Reference Map: G.S.G.S. 4347/40-16 NE.  
The two concrete which are already shown on the defence overprints  
at 207795 are type 677.  
Air Cover: Sortie: 140/157 Photo Nos: 4066/7.  
of 22 May 44.
5. DEANVILLE. Reference Map: G.S.G.S. 4347/43-18 SE.  
There is a shelter at 43941267 and a pillbox at 43301230.  
Air Cover: Sortie: 140/157 Photo Nos: 4041/4.  
of 22 May 44. Date of Information: 22 May 1944.
6. DEANVILLE. Reference Map: G.S.G.S. 4347/43-18 SE.  
The concrete at 42351110 has been completed; it is connected by a  
short road to an emplacement at 42321112. There are three small dug-outs  
at 421114.  
Air Cover: Sortie: 140/157 Photo Nos: 4045/6.  
of 22 May 44. Date of Information: 22 May 1944.
7. NEDEWILLE. Reference Map: G.S.G.S. 4347/43-18 SE.  
There is a pillbox at 40701066 and a trench between the coast road  
and the beach from 40341036 to 40471026.  
Air Cover: Sortie: 140/157 Photo Nos: 4048/50.  
of 22 May 44. Date of Information: 22 May 1944.

CONFIDENTIAL  
TOP SECRET  
BIGOT  
95P/CTOP SECRET  
BIGOT

/8.....

0082

8. RENOUVILLE. Reference Map: G.S.G.S. 4347/40-18 SE.  
 There is a shelter at 41941102, 4189107, 4194107 and a crater under construction at 41941102.  
Air Cover: Sortie: 140/157 of 22 May 44. Photo Nos: 4036/8.  
Date of Information: 22 May 1944.
9. TRONVILLE. Reference Map: G.S.G.S. 4347/40-18 SE.  
 There is a shelter at 45531403, a concrete under construction at 45281380, and seven small dug-outs at 45961315.  
Air Cover: Sortie: 140/157 of 22 May 44. Photo Nos: 4037/8.  
Date of Information: 22 May 1944.
10. VILLAINES-la-CARVILLE. Reference Map: G.S.G.S. 4250/865.  
 An unidentified camouflaged installation at 507024.  
Air Cover: Sortie: 16/221 of 15 May 44. Photo Nos: 4052/3.  
Date of Information: 15 May 1944.
11. VER SUR MER. Reference Map: G.S.G.S. 4347/37-18 SE.  
 The trench system at 909851 has been extended and several new firing points have been added.  
Air Cover: Sortie: 4/109 of 27 May 44. Photo Nos: 3023/4.  
Date of Information: 27 May 1944.
12. VILLERS SUR MER. Reference Map: G.S.G.S. 4347/40-18 SE.  
 There is a concrete shelter 40 feet square at 28858265 and 29058267.  
Air Cover: Sortie: 140/157 of 22 May 44. Photo Nos: 4055/6.  
Date of Information: 22 May 1944.
13. VAUX. Reference Map: G.S.G.S. 4347/37-18 SE.  
 The emplacements at 935859 and 938858 are now occupied.  
Air Cover: Sortie: 140/157 of 22 May 44. Photo Nos: 3147/8.  
Date of Information: 22 May 1944.  
Comment:  
 They are probably 75 mm. Anti-Tank guns.
14. LE HONNE SUR MER. Reference Map: G.S.G.S. 4347/40-16 NE.  
 There is a pillbox at 19007958.  
Air Cover: Sortie: 16/259 of 24 May 44. Photo Nos: 4023/4.  
Date of Information: 24 May 1944.
15. ST. GEORGES HOTEL. Reference Map: G.S.G.S. 4250/985.  
 There are several concrete shelters in the grounds of the Chateau MAISON at 327408.  
 /Air Cover.....

-2-

8. BREHUVILLE.

There is a shelter at 41941102, 41941103, 41941104 and a concrete  
under construction at 41941102.

Air Cover: Sortie: 140/157  
of 22 May 44.

Photo Nos: 4011/8.

Date of Information: 22 May 1944.

9. YMAVILLE.

There is a shelter at 45531403, a concrete under construction at  
45281380, and seven small dug-outs at 45961315.

Air Cover: Sortie: 140/157  
of 22 May 44.

Photo Nos: 4037/8.

Date of Information: 22 May 1944.

10. VILLAINES-la-CARLE.

An unidentified camouflaged installation at 507024.

Air Cover: Sortie: 16/224  
of 15 May 44.

Photo Nos: 4052/3.

Date of Information: 15 May 1944.

11. VER SUR MER.

The trench system at 909851 has been extended and several new  
firing points have been added.

Air Cover: Sortie: 4/109  
of 27 May 44.

Photo Nos: 3023/4.

Date of Information: 27 May 1944.

12. VILERS SUR MER.

There is a concrete shelter 40 feet square at 28358265 and 29058267.

Air Cover: Sortie: 140/157  
of 22 May 44.

Photo Nos: 4055/6.

Date of Information: 22 May 1944.

13. YANK.

The emplacements at 935859 and 938058 are now occupied.

Air Cover: Sortie: 140/157  
of 22 May 44.

Photo Nos: 3147/8.

Date of Information: 22 May 1944.

Comment:

They are probably 75 mm. anti-Tank guns.

14. LE NOUVE SUR MER.

There is a pillbox at 19007958.

Air Cover: Sortie: 16/259  
of 24 May 44.

Photo Nos: 4023/4.

Date of Information: 24 May 1944.

15. ST. GEORGES HOTEL.

There are several concrete shelters in the grounds of the Chateau  
MILIN at 327408.

Reference Map: G.S.G.S. 4250/975.

/Air Cover.....

0084

TOP SECRET  
BIGOT  
-3-

Air Cover: None.

Comment:

Date of Information: 28 April 1944.

This is a C.A.F. Headquarters of some importance and is likely to have such shelters. Source does NOT state the number nor their exact location.

16. UNDESE.

Reference Map: G.S.G.S. 4250/765.

There is a large pillbox near the viaduct at 818728.

Air Cover: None.

Date of Information: January 1944.

17. LA ROCHE.

Reference Map: G.S.G.S. 4347/28-20 NE.

There are four 81 mm. mortars at 989167.

Air Cover: None.

Date of Information: 22 February 1944.

18. DILETTE.

Reference Map: G.S.G.S. 4347/28-20 NE.

There are five pillboxes in the area of 963145.

Comment:

Date of Information: 22 February 1944.

The latest overprints show one casemate and two pillboxes. The other two pillboxes can NOT be seen on air cover.

19. LA VIEVILLE.

Reference Map: G.S.G.S. 4347/28-20 NE  
& NW.

A new strongpoint has been developed at 992157. It consists of five probable mortar positions at 991157, two probable and two possible light field guns in unprepared positions at 992157. There are a number of minor field works under construction in the area.

Air Cover: Sortie: 16/260  
of 24 May 44.

Photo Nos: 3148/9.

Date of Information: 24 May 1944.

20. ST. CROIX GRAND TONNE.

Reference Map: G.S.G.S. 4347/37-16 NE.

Possible shelters at 860752, 860753 and 863752. Three dug-outs under construction at 865755.

Air Cover: Sortie: 400/156  
of 25 May 44.

Photo Nos: 3124/6.

Date of Information: 25 May 1944.

21. ST. CROIX GRAND TONNE.

Reference Map: G.S.G.S. 4347/37-16 NE.

A light field or Anti-Tank gun at 902768 and a possible gun at 831762.

Air Cover: Sortie: 400/151  
of 24 May 44.

Photo Nos: 3165/6 & 4164/5.

Date of Information: 24 May 1944.

22. ST. CROIX GRAND TONNE.

Reference Map: G.S.G.S. 4347/37-16 NE.

Possible light field or Anti-Tank gun at 858751.

Air Cover: Sortie: 400/156  
of 25 May 44.

Photo Nos: 3125-6.

Date of Information: 25 May 1944.

/23.....

TOP SECRET  
BIGOT

0 0 8 5



TOP SECRET

23. STE. COIX GRAND TRENCH. **BIGOT** Reference Map: G.S.G.S. 4347/37-16 NE.  
The light field or Anti-Tank gun position at 06377505 is now occupied.  
Air Cover: Sortie: 400/156 Photo Nos: 3125/6.  
of 25 May 44. Date of Information: 25 May 1944.
24. STE. COIX GRAND TRENCH. Reference Map: G.S.G.S. 4347/37-16 NE.  
A trench system has been completed round the light field or Anti-Tank  
gun position at 06377507 and the gun has now been removed. There is a new  
occupied position at 06327532, where there is a lack of the usual associated  
features; it may only be a temporary position for the gun which was at 05757537.  
Air Cover: Sortie: 400/156 Photo Nos: 3125/6.  
of 25 May 44. Date of Information: 25 May 1944.  
Reference Map: G.S.G.S. 4347/31-16 NE.
25. LA BARRIE.  
There are possible bench lights at 133705 and 131723.  
Air Cover: Sortie: 16/260 Photo Nos: 3095/6, 3098/9.  
of 24 May 44. Date of Information: 24 May 1944.  
Reference Map: G.S.G.S. 4347/31-16 NE.
26. LIGN SUR MER. Reference Map: G.S.G.S. 4347/40-18 SW.  
There are probable breastworks at 060806.  
Air Cover: Sortie: 140/157 Photo Nos: 3116/7.  
of 22 May 44. Date of Information: 22 May 1944.  
Reference Map: G.S.G.S. 4347/40-16 NE.
27. FRANCEVILLE PLAGE.  
There is a pillbox at 15057927 and 15837928, four ditches at 153792  
and a trench system with machine gun posts from 15257905 - 15057918 - 15127827 -  
15037835.  
Air Cover: Sortie: 1060/556 Photo Nos: 4066/7, 4070/1, 4085/6.  
of 28 May 44. Date of Information: 28 May 1944.  
Reference Map: G.S.G.S. 4347/31-20 NE.
28. CHATELAIN.  
A new position is under construction at 373165. Six dug-outs and a  
strip of firing trench have already been built.  
Air Cover: Sortie: 16/294 Photo Nos: 3021/2.  
of 27 May 44. Date of Information: 27 May 1944.  
Reference Map: G.S.G.S. 4347/40-16 NE.
29. STE. ANNE MARQUENY.  
There is a new strongpoint at 103763. Two lengths of trench lead  
to machine gun positions at 102764, 103763 and to a pillbox at 103762.  
Air Cover: Sortie: 400/157 Photo Nos: 4075/6.  
of 25 May 44. Date of Information: 25 May 1944.  
Reference Map: G.S.G.S. 4347/40-16 NE.
30. STE. ANNE MARQUENY.  
There is a probable Anti-Tank gun at 071768.  
Air Cover: Sortie: 400/157 Photo Nos: 3156/7.  
of 25 May 44. Date of Information: 25 May 1944.  
Reference Map: G.S.G.S. 4347/40-16 NE.

TOP SECRET

0086

/31.....

TOP SECRET  
BIGOT

-5-

31. WINDYVILLE.Reference Map: G.S.G.S. 4347/40-16 NE.

There is a pillbox SOUTH of the bridge at 05957475 and a probable pillbox NORTH of the bridge at 10057485.

Air Cover: Sortie: 400/157  
of 25 May 44.Photo Nos: 3126/7.Date of Information: 25 May 1944.32. SPRINGVILLE.Reference Map: G.S.G.S. 4347/31-18 NE.

The shelter trenches and pronounced track activity at 301973 suggest military occupation of farm buildings.

Air Cover: Sortie: 16/262  
of 24 May 44.Photo Nos: 3060.Date of Information: 24 May 1944.33. LE FORT.Reference Map: G.S.G.S. 4347/31-18 NE.

There is an unoccupied emplacement for a probable Anti-Tank gun at 327917.

Air Cover: Sortie: 16/262  
of 24 May 44.Photo No: 3048.Date of Information: 24 May 1944.34. GRAND-GRAND.Reference Map: G.S.G.S. 4347/37-13 NE.

There are two open circular emplacements, probably for light guns at 953852 and 954853.

Air Cover: Sortie: 1064/517  
of 27 May 44.Photo Nos: 3003/4.Date of Information: 27 May 1944.35. CHENIERES.Reference Map: G.S.G.S. 4347/40-18 SE.

There is a dug-out at 049310, 050012 and three at 054805.

Air Cover: Sortie: 400/157  
of 25 May 44.Photo Nos: 3211/4.Date of Information: 25 May 1944.C-2 (Intelligence) Division,  
G.I.E.P.  
30 May 1944.TOP SECRET  
BIGOT

0087

TOP SECRET  
BIGOT

TOP SECRET

MISSION 'E' TO NEPTUNE AREA NO. 52  
Dated 30 May 1944Obstacles in the NEPTUNE AreaUnderwater Obstacles

- 1.
- ROCKS ON ROE
- Reference Map: 6868 4347/28/18 NE.

A staggered row of rocks, interspersed at one point with some possible tetrahedra, is seen in front of previously reported obstacles. It runs from 9790950 to 9790912, from 9790940 to 9790975 and from 9800970 to 9800970.

Air Cover: Sortie 140/307 Photo Nos: 4054-3  
of 28 May 1944

- 2.
- BAIRS DE BOURNEVILLE
- Reference Map: 6868 4347/23/18 SE.

Stakes extend from 422118 to 427121. The overall width of this belt of obstacles, which appears on the defence map at 422117 as "100 feet", is now approximately 650 feet.

Air Cover: Sortie 14 J13 Photo Nos: 4090-2  
of 28 May 1944

- 3.
- TRONVILLE
- Reference Map: 6868 4347/42/18 SE.

A belt of obstacles, probably rocks, is seen in front of the previously reported obstacles between 443138 and 450140.

Air Cover: Sortie 16 J13 Photo Nos: 3041-2  
of 28 May 1944

- 4.
- MCSALLIES
- Reference Map: 6868 4340/70.

Recent extensions in this area are shown on a tracing attached. In view of the number of amendments which have been issued since the original tracing in NEPTUNE AREA NO. 2, a new tracing is issued with this report.

- 5.
- OUJESNEVAL
- Reference Map: 6868 4420/36.

Elements 'C' in this area have been spread out and three more units added to make a total of 16 (See tracing attached).

- 6.
- MEYRONVILLE
- Reference Map: 6868 4347/43/18 SE.

A scattered belt of stakes runs in front of previously reported obstacles from 462130 to 462136.

Air Cover: Sortie 16 J13 Photo Nos: 3043-6  
of 28 May 1944

- 7.
- SEVILLE
- Reference Map: 6868 4347/28/20 SE.

A staggered row of hedgehogs or stakes runs from 982011 to 983019.

/Enc.....

95210

TOP SECRET  
BIGOT

0088

TOP SECRET  
BIGOT

- 2 -

The staggered rows of tetrahedra or hedgehogs previously reported have been extended from 982004 to 982006 and have become intermingled with ramps previously laid in this area.

Air Cover: Sertic 140/207      Photo No: 4046-3  
of 29 May 1944.

6. POINTE DE BREVANS -      Reference No: G333 4490/75 & 76  
POINTE DE BREVANS

Thin stakes of the type believed to be used for fishing nets are seen between the following points :-

456921-455919; 453918-452911; 456918-458915; 462918-463917; 485901-488899; 487899-486897; 487897-486897; 491890-492899.

Air Cover: Sertic 106 G/321      of 27 May 1944.  
32.31/403

9. POINTEVILLE AREA      Reference No: G333.4490/75

A tracing is attached showing the latest developments in the southern part of this map sheet.

In the N.-W. part of the map sheet the front row of hedgehogs has been wired between 414025 and 415000; the second row of hedgehogs has been wired between 41650192 and 41750173.

At 41980142 an unidentified object is seen. (See para. 6 of the text of this report).

Stakes are seen lying at the back of the beach throughout the area.

Air Cover: Sertic 16/328 of 29 May 1944.

G-2 (Intelligence) Division,  
SHANE.  
30 May 1944.

TOP SECRET  
BIGOT

0089

TOP SECRET  
BIGOT

Issued with Appendix 'B' to WETLINE ARGUS NO. 31

TOP SECRET.

Dated 30 May 1944.

G.S.G.S. 4490, Sheet 73, FOUCHARVILLE, 1/12,500.

This tracing is a complete replotting of this part of the map sheet.

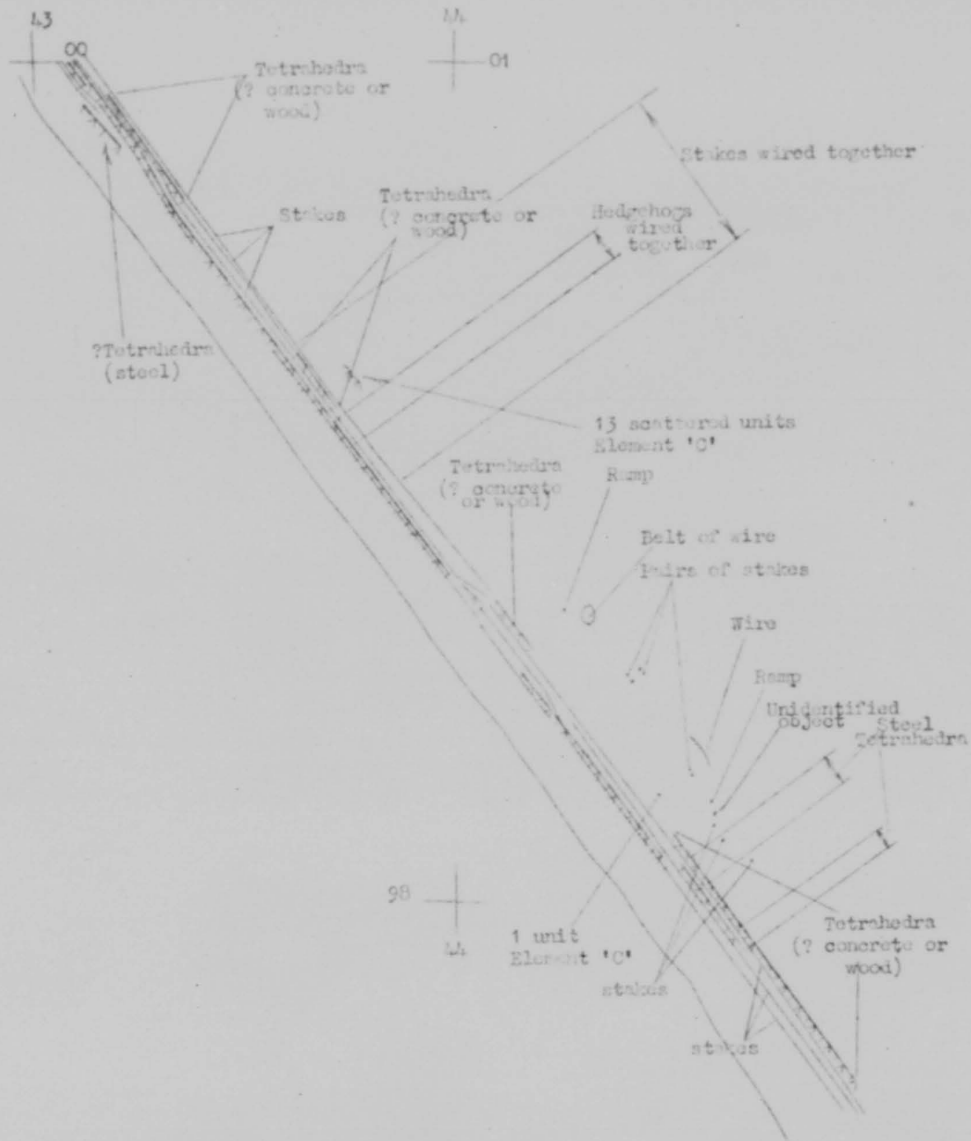

Air Cover: Sortie: 16/328 of 29 May 44.

G-2 (Intelligence) Division,

SHARP.

30 May 1944.

TOP SECRET  
BIGOT

0090

BIGOT

TOP SECRET

Issued 4th SEPTEMBER 1947 to SUPPLY POINT NO. 22  
 WITH 21/10/47 Add-

The information below is additional to  
 that given on the tracing issued in the  
 SUPPLY POINT NO. 22  
 Dettle 16/513 of 20 May 1946.

OSGS Map, sheet 79, VIERVILLE, 1:125,000

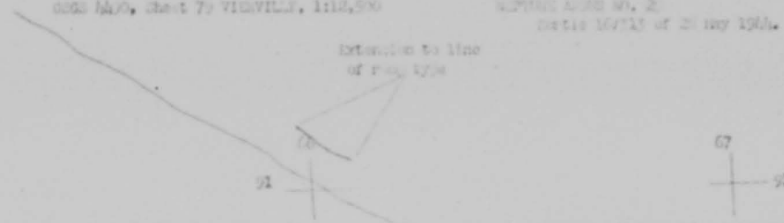

The information below is additional to  
 that shown on the tracing issued in the  
 SUPPLY POINT NO. 27.

Dettle 16/513 of 20 May 1946.

Additional line  
 of road type

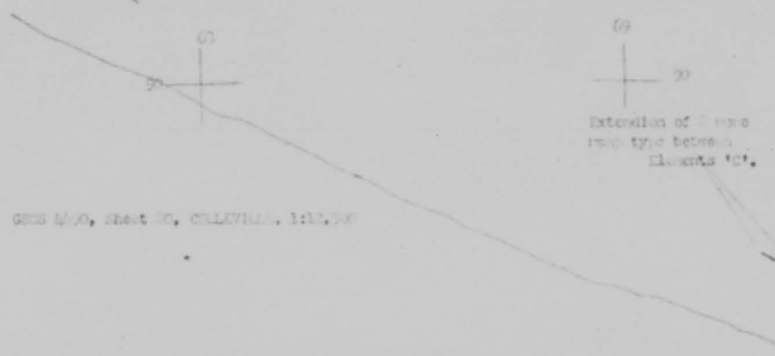

OSGS Map, sheet 80, CHALEVILLE, 1:125,000

Extension of road  
 type between  
 elements 'C'.

Stakes

7 This states

Extension of 3 rows  
 of

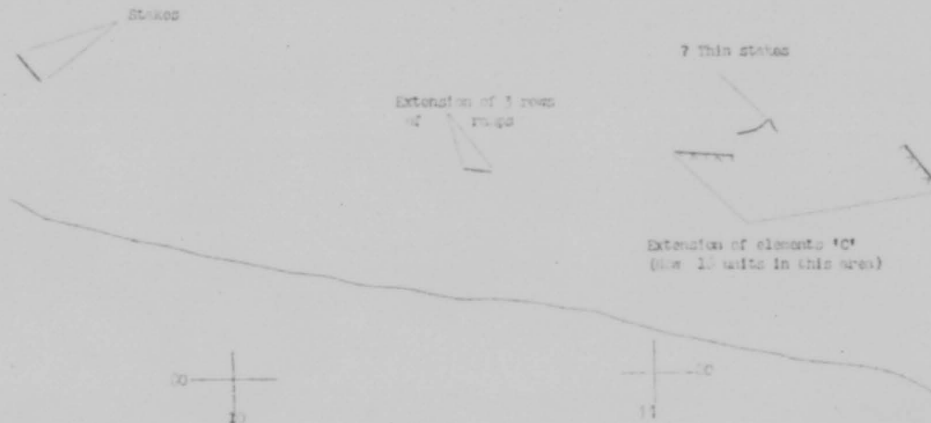

OSGS Map, sheet 86, OSTROSOW, 1:125,000  
 Dettle 16/513 of 20 May 1946.

The information above is additional to  
 that shown on the tracing issued in the  
 SUPPLY POINT NO. 7.

G-2 (INTELLIGENCE) DIVISION  
 STAFF.  
 30 May 1946.

TOP SECRET  
 BIGOT

TOP SECRET  
BIGOT

TOP SECRET.

Issued with Appendix 'N' to NEPTUNE ARGUS NO. 33 dated 30 May 44.

G.S.G.S. M20, Sheet 51, REFERENCE, 1/11,500.

The information below is additional to that shown on the tracing issued in the NEPTUNE ARGUS NO. 30.

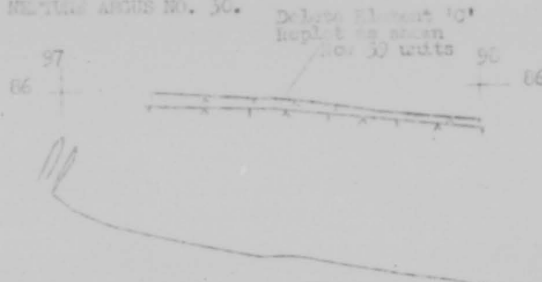

Air Cover: Sortie: 1060/517 of 27 May 44. Photo No. 4019.

G.S.G.S. M20, Sheet 72, REFERENCE, 1/12,500.

This tracing is a copy to replotting of this part of the map sheet.

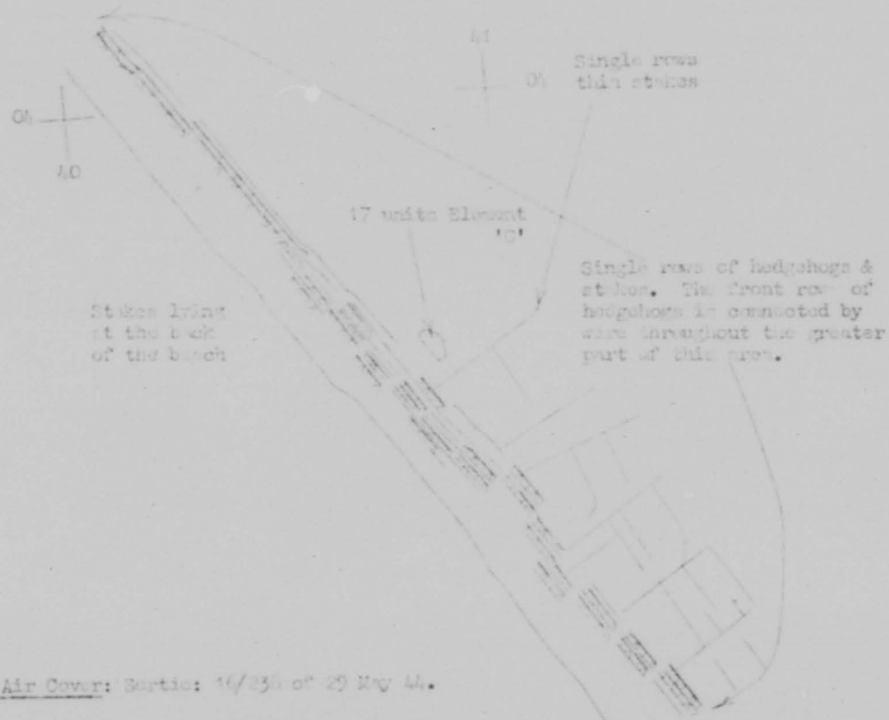

Air Cover: Sortie: 16/236 of 29 May 44.

G-2 (Intelligence) Division,  
STAFF.  
30 May 1944.

TOP SECRET  
BIGOT

0092



TOP SECRET  
BIGOT

Issued with Appendix 'A' to REPORT AREA NO. 11  
dated 20 May 1944.

TOP SECRET

G.S.C. 4490. Sheet 7b. ARDOVILLE LA HERMIT.  
1:12,500

The information below is additional to that shown on the tracing  
issued in the REPORT AREA NO. 15.

Carte 15/258 of 29 May 1944.

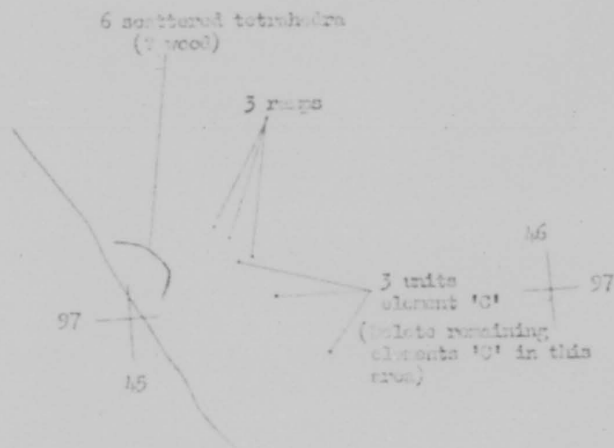

G-2 (Intelligence) Division,  
SHAF.  
20 May 1944.

TOP SECRET  
BIGOT

0093

# BIGOT

TOP SECRET

ISSUED WITH APPENDIX B TO REFERENCE ARGUS NO. 33  
 DATED 30 MAY 44

G.S.G.S. 4490 Sheet 70 ST. VAAS-1A-10000  
 1-12-50

This tracing supersedes all previous  
 traces and tracings of this map  
 sheet.

Bortie 1066/556 of 28 May 44.

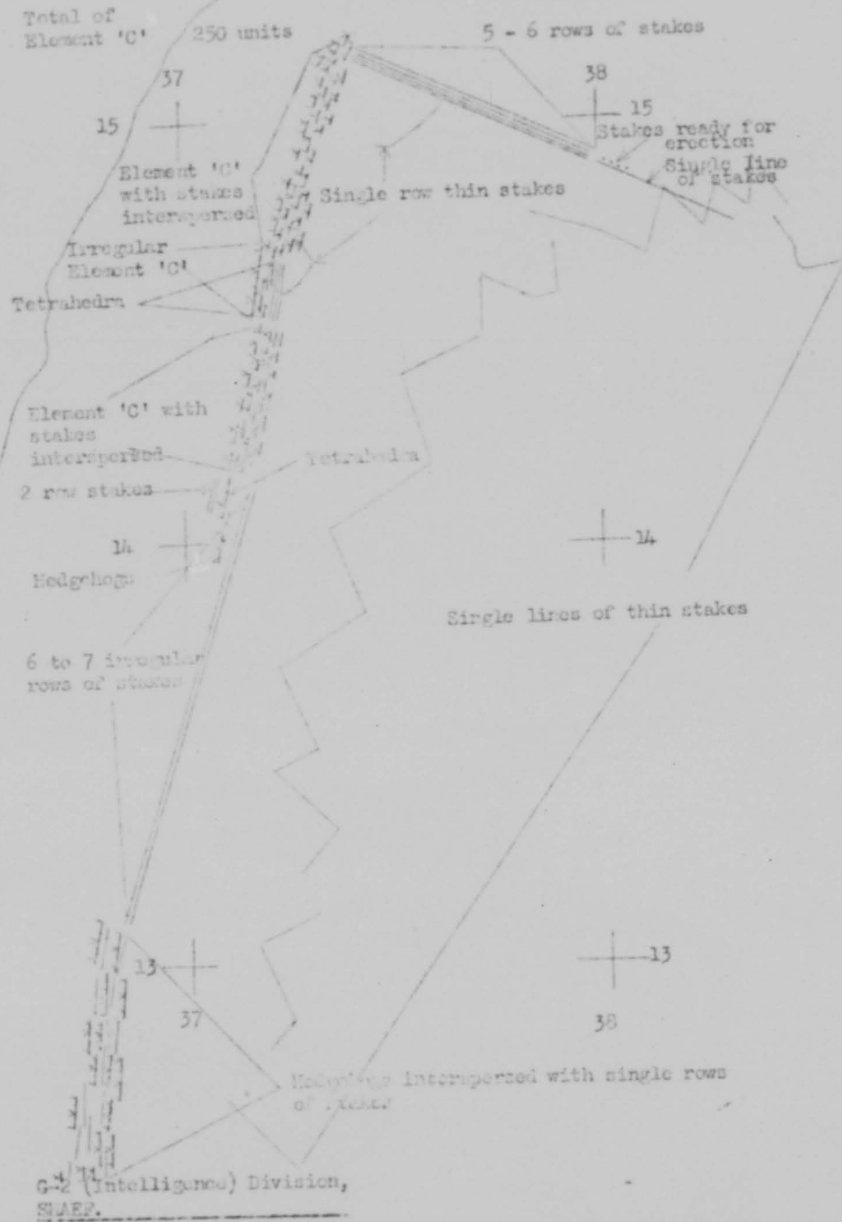

TOP SECRET  
 BIGOT

0094

APPENDIX 'G' TO REPORT 'G' dated 30 May 1944.

TOP SECRET  
BIGOT

TOP SECRET.

AMMUNITION DUMPS

1. FRANCE: ELBEUF/ONIVAL  
(SEINE INFERIEURE)      Reference Map: GSGS 4250/8F2  
Date of Information: Not given.  
  
Source reports ammunition dump in tunnel on railway line to ELBEUF, near ONIVAL (103002-102010).  
  
Source: Ground  
Air Cover: None  
  
Comment:  
It will be recalled that previous reports have indicated the presence of a headquarters train as well as ammunition stores in the tunnel. Air photographs show that the track at the two entrances of the tunnel has been camouflaged.  
  
Amendment to: TIS/D.IV/DEF/8.2
2. FRANCE: LE HAYE  
(SEINE INFERIEURE)      Reference Map: 4250/7E4 & 8E3/507279  
Date of Information: Feb. 44. (approx)  
  
Possible ammunition or stores dump in tramway tunnel between Rue CLOVIS and the Rue GENERAL ROUELLE, South of the CLOSTIERRE ST. MARIE.  
  
Source: Ground  
Air Cover: None  
  
Amendment to: TIS/D.IV/DEF/8.2
3. FRANCE: M.INTENON/EPERON  
(SURE ST LOIR)      Reference Map: GSGS 4250/9G4 & 9G2  
Date of Information: 29 March 1944.  
  
Before the bombing of the M.INTENON dump on 30 April/1 May 1944 there was apparently considerable traffic in munitions bound for the depot. Source mentions that 200 waggons loaded with munitions were parked each night between 2200 hours and 1000 hours between M.INTENON and EPERON over a distance of 10 kms.  
  
Source: Ground  
Air Cover: None  
  
Amendment to: TIS/D.IV/DEF/8.2
4. FRANCE: MEZIDON (CALVADOS)      Reference Map: GSGS 4250/7F4  
Date of Information: None Given  
  
Ground source reports ammunition factory at MEZIDON, situated along railway line.  
  
Source: Ground  
Air Cover: None  
  
Comment:  
This installation is probably connected with the known ammunition dumps at 260522 and 247544. The MEZIDON dump was thought to be inactive, but recent information points to a certain degree of /activity.

TOP SECRET  
BIGOT

0095

BIGOT

activity.

Amendment to: TIS/D.IV/DEF/8.25. FRANCE: LE MAJIS (SARTHE)Date of Information: March to April 44.

Continued movement of munitions from the EAST towards LE MAJIS region. 625 wagons from 26.3.44 to 15.4.44. Principal destinations: MAINTENON (417), CHATEAULIN, NEUILLY-LE-RISSON (92).

Source: GroundAir Cover: NoneComment:

LE MAJIS is known to be an important ammunition railway distributing point and movements from GERMAIN (principally from COLOGNE) are regular. It is likely that the ammunition to MAINTENON was principally for the G.A.F.

Amendment to: TIS/D.IV/DEF/8.26. FRANCE: FORST LE BROTONNE (SURE)Reference Map: CGCS 4250/826Date of Information: 6 May 1944

It appears that work is going on in the FORST LE BROTONNE. There is no indication yet as to its nature or purpose.

Sources: Air and Ground.Air Cover: GoodComment:

Air cover of April and May 1944 shows that there is a large quantity of stores along the sides of the road between 917221 and 917226, and also at 917220 and 917224. Small collections of stores and unidentifiable activity can be seen in many parts of the wood. Possible ammunition or stores dump.

Amendment to: TIS/D.IV/DEF/8.2.7. FRANCE: MAUVES-SUR-LOIRE (LOIRE INFERIEURE)Reference Map: CGCS 40409/105 SW/186618.Date of Information: 2 April 1944

Underground ammunition dump under construction in former quarries at 186618 (marked "Carrieres" on the map). The Germans have dug galleries, of which 6 are visible, intended for ammunition storage. The galleries are 8m. in diameter and are protected by 50m. of earth.

Source: GroundAir Cover: NoneComment:

A previous ground report of February 1944 stated that large excavations were going on in quarries along the LOIRE, especially in the MAUVES district.

Amendment to: TIS/D.IV/DEF/8.2

/8.

TOP SECRET

BIGOT

0096

## BIGOT

8. FRANCE: LOUJILLAS/FRÉCHENE: Reference Map: Air 5000/92 SW  
FORÊT DE BILPÈRE (SARRE) 47°46'15" N.  
 02°36'03" W.E.
- Date of Information: 15 April 1944.
- ammunition dump in forest covering 3-4 square km. Code name "MULLER".
- Before the bombing of 6/7 Aug 44, which inflicted heavy damage on the dump, it contained rifle cartridges, machine guns, 20, 27 and 37 mm anti-tank ammunition, many 75 mm shells, and various kinds of all sizes. It was served by roads and by a single track railway from LOUJILLAS. Military personnel of the dump numbered about 500 men, mostly Infantry, but some GAF. There were about 200 civilian workers employed at the dump.
- Ground source states that the munitions, which were formerly carefully dispersed, were before the bombing placed pell-mell in the wood, without even the most elementary precautions being taken.
- Source: Ground
- Air Cover: None
- Amendment to: TIS/D.IV/DEF/8.2
9. FRANCE: FORÊT DE QUÉRICY (SARRE) Reference Map: GSGS 4040B/74 NW  
 (SARRE) (Square 94-95/71-72)
- Date of Information: 4 Feb. 44
- ammunition dump in FORÊT DE QUÉRICY. Code name reported to be "LINFRED", PHN 39,900. Possible A.L.
- Source: Ground
- Air Cover: None
- Amendment to: TIS/D.IV/DEF/8.2
10. FRANCE: SENONCHES Reference Map: GSGS 4750/8G4 & 9G3  
 (EURE ET LOIR) (069149)
- Date of Information: 20 April 1944.
- Ground source reports heavy shipments of ammunition from SENONCHES dump in direction of VARENNES and passing through DREUX - 400 trains.
- Source: Ground
- Air Cover: None
- Amendment to: TIS/D.IV/DEF/8.2

G-2 (Intelligence) Division,  
 SLEEF.  
 30 May 1944.

TOP SECRET  
 BIGOT

7 7 8 0  
 0 0 9 7

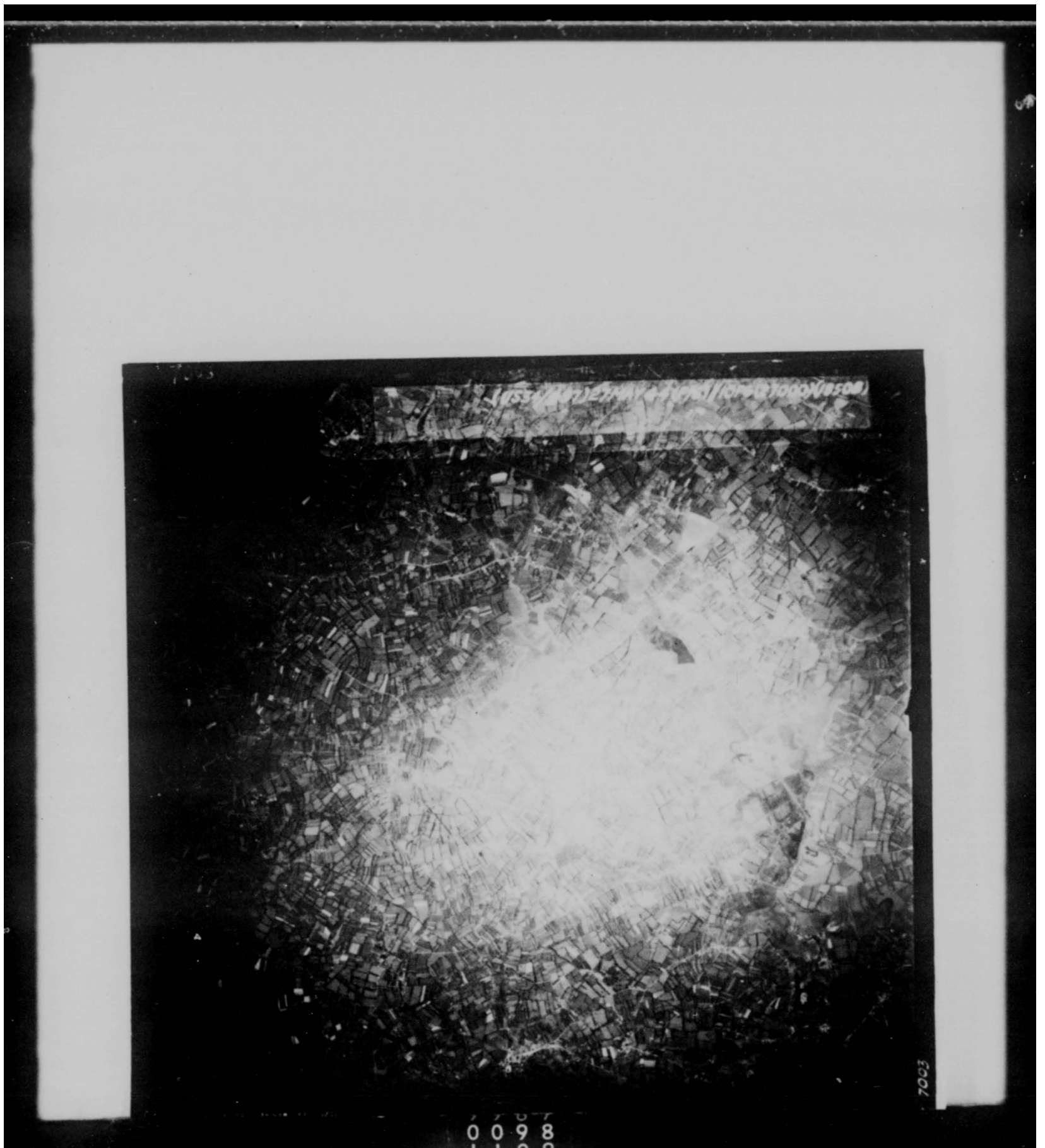

0098

7003





1007

1007

0099 (F16) // 110PG(28000)(1035B)

0099







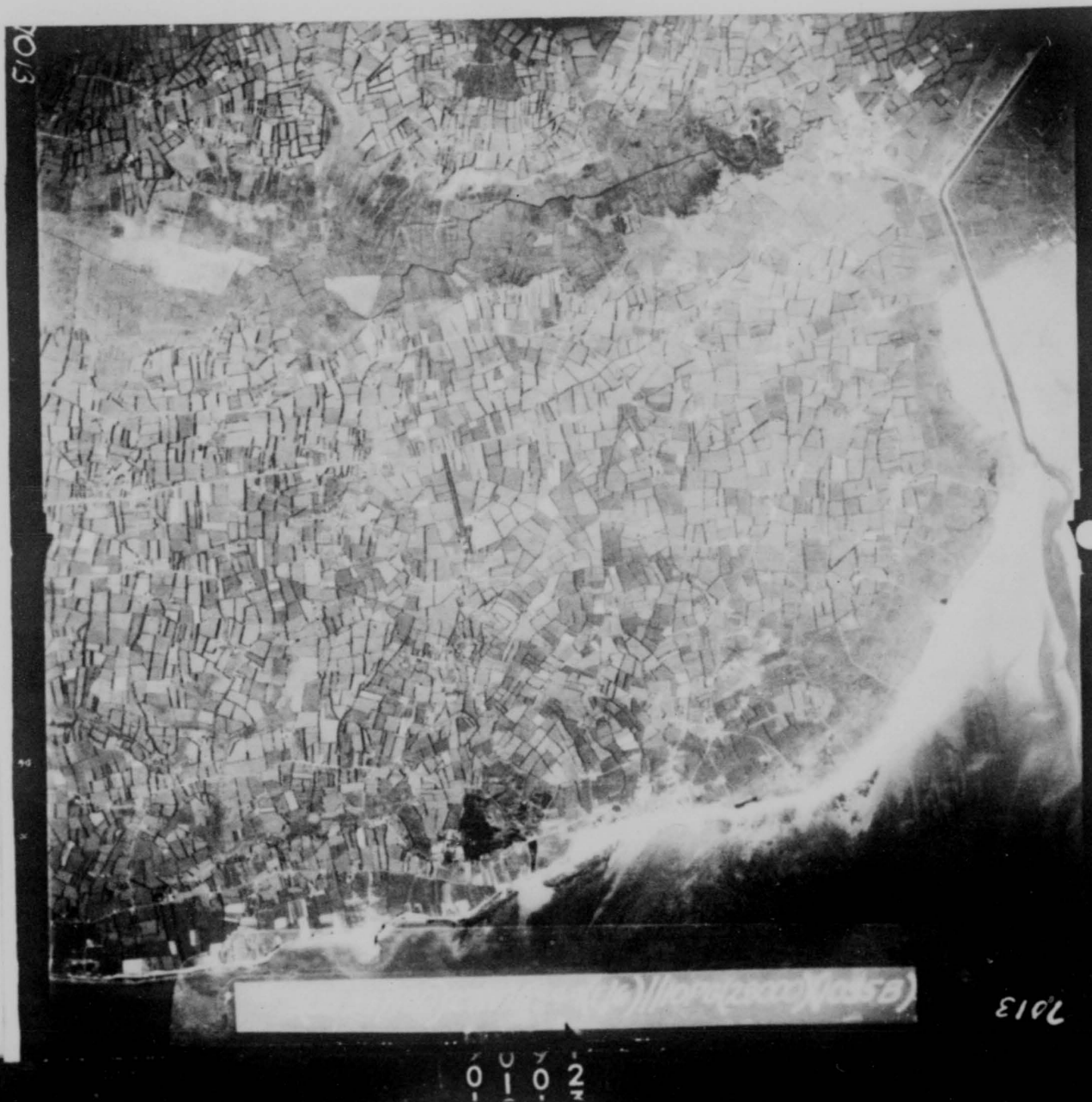

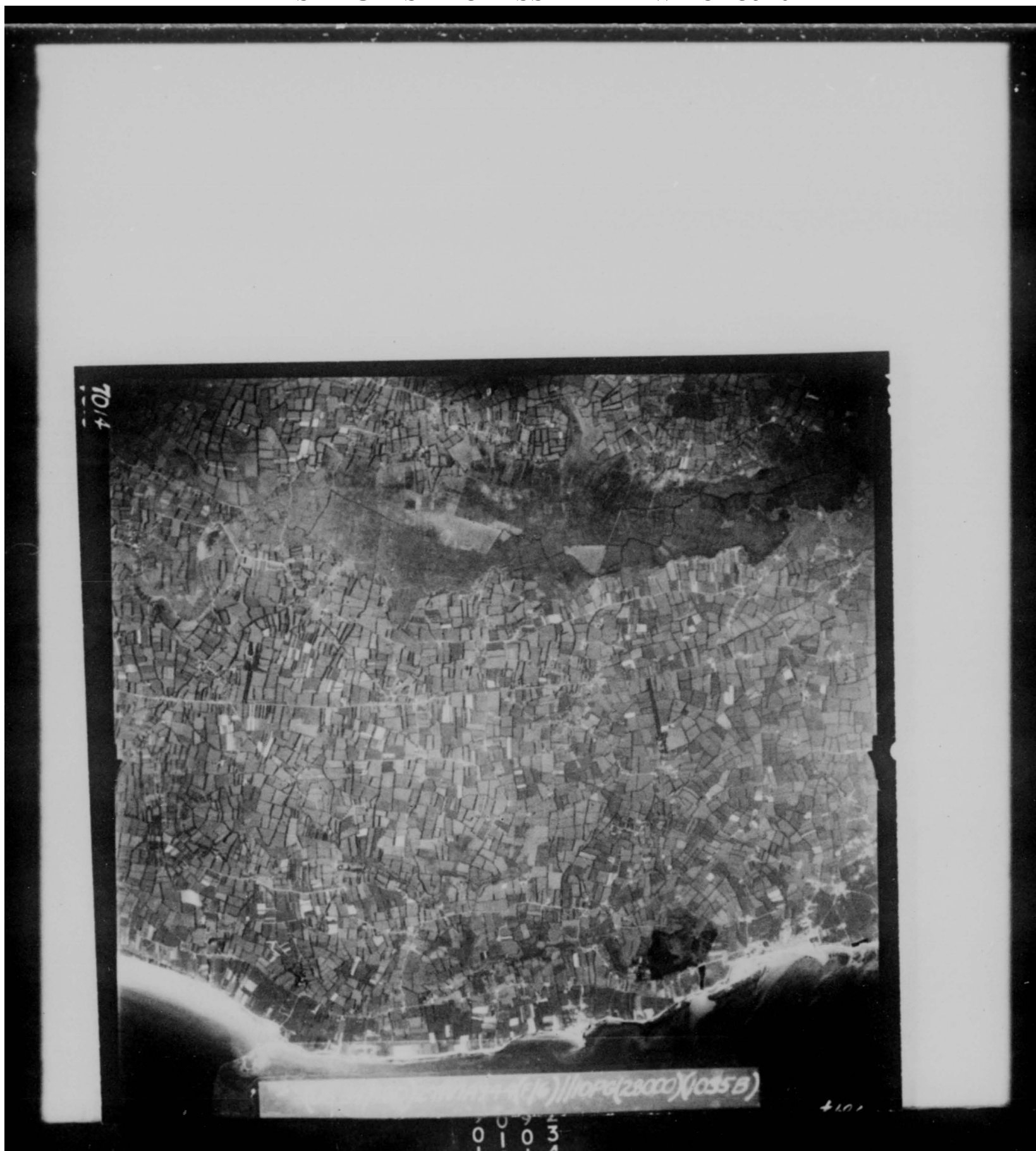









7006

(28,000)(18508)

7006

7006



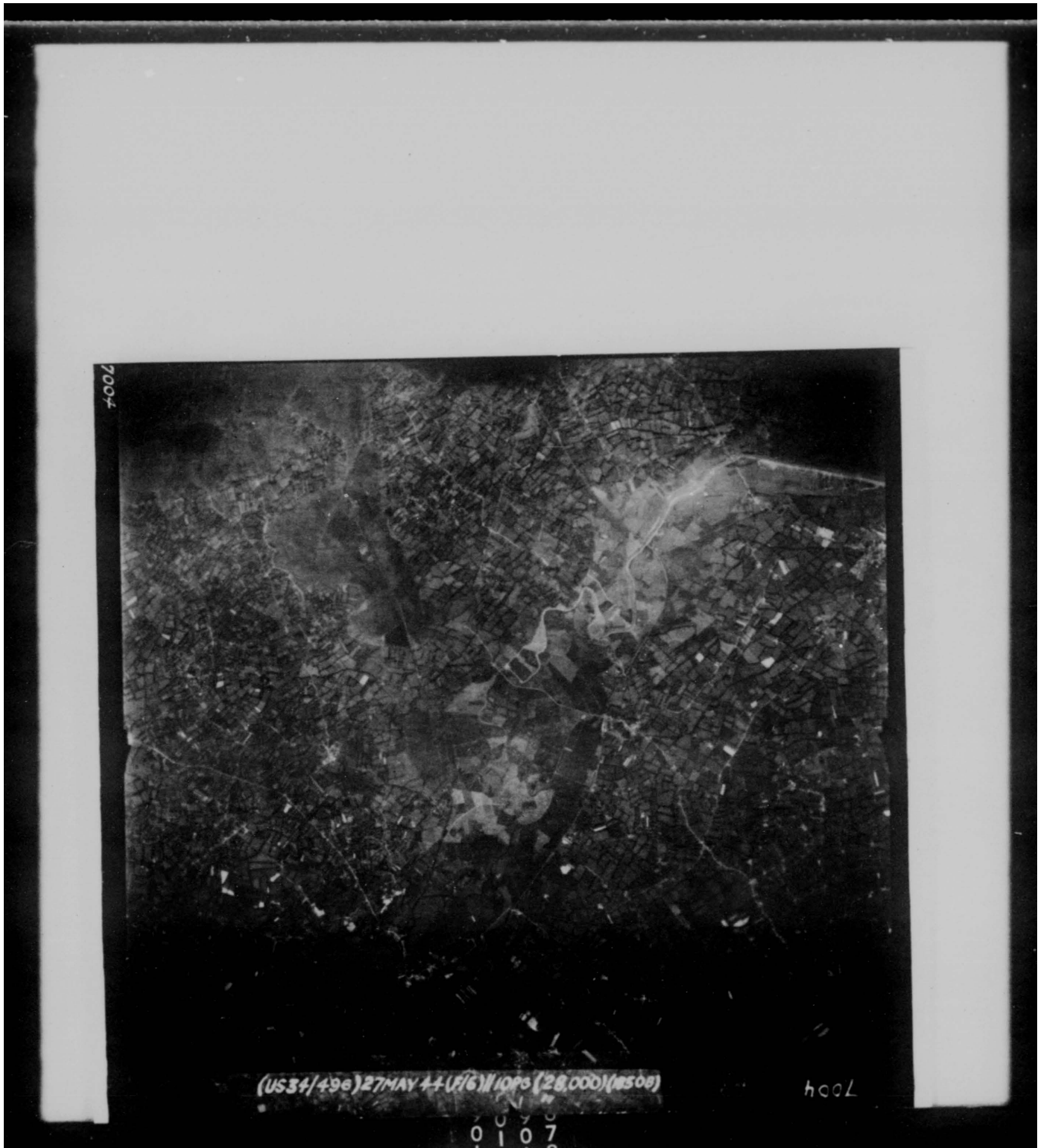

7004

(US34/496) 27 MAY 44 (F/6) // 1000 (28,000) (ms0e)

hool

0 1 0 7



7003

(U33+) + (-) 27 MAY + F/6 // 10F3 (28,000) (1950B)

0108

THIS PAGE IS DECLASSIFIED IAW EO 13526

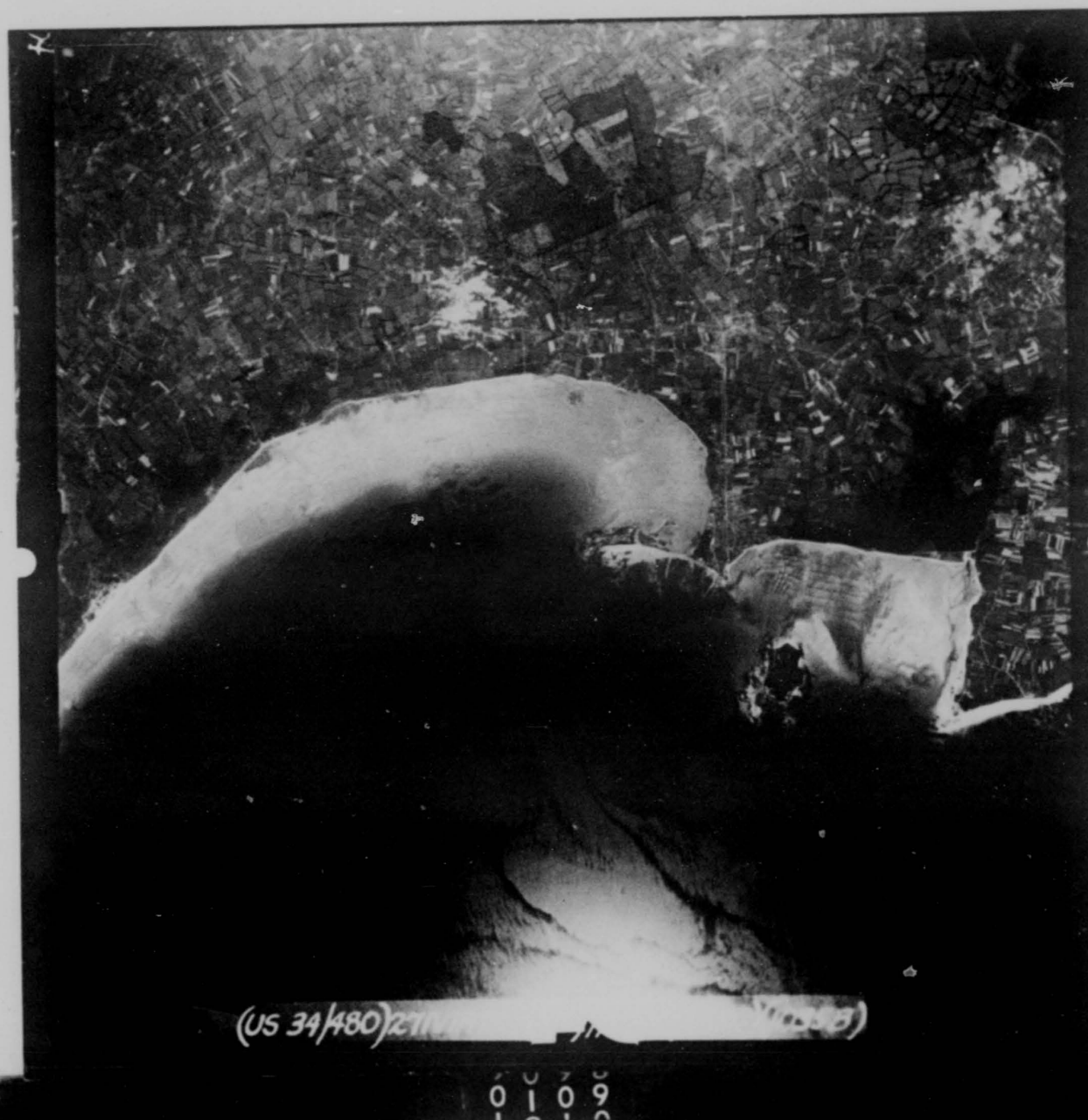

THIS PAGE IS DECLASSIFIED IAW EO 13526

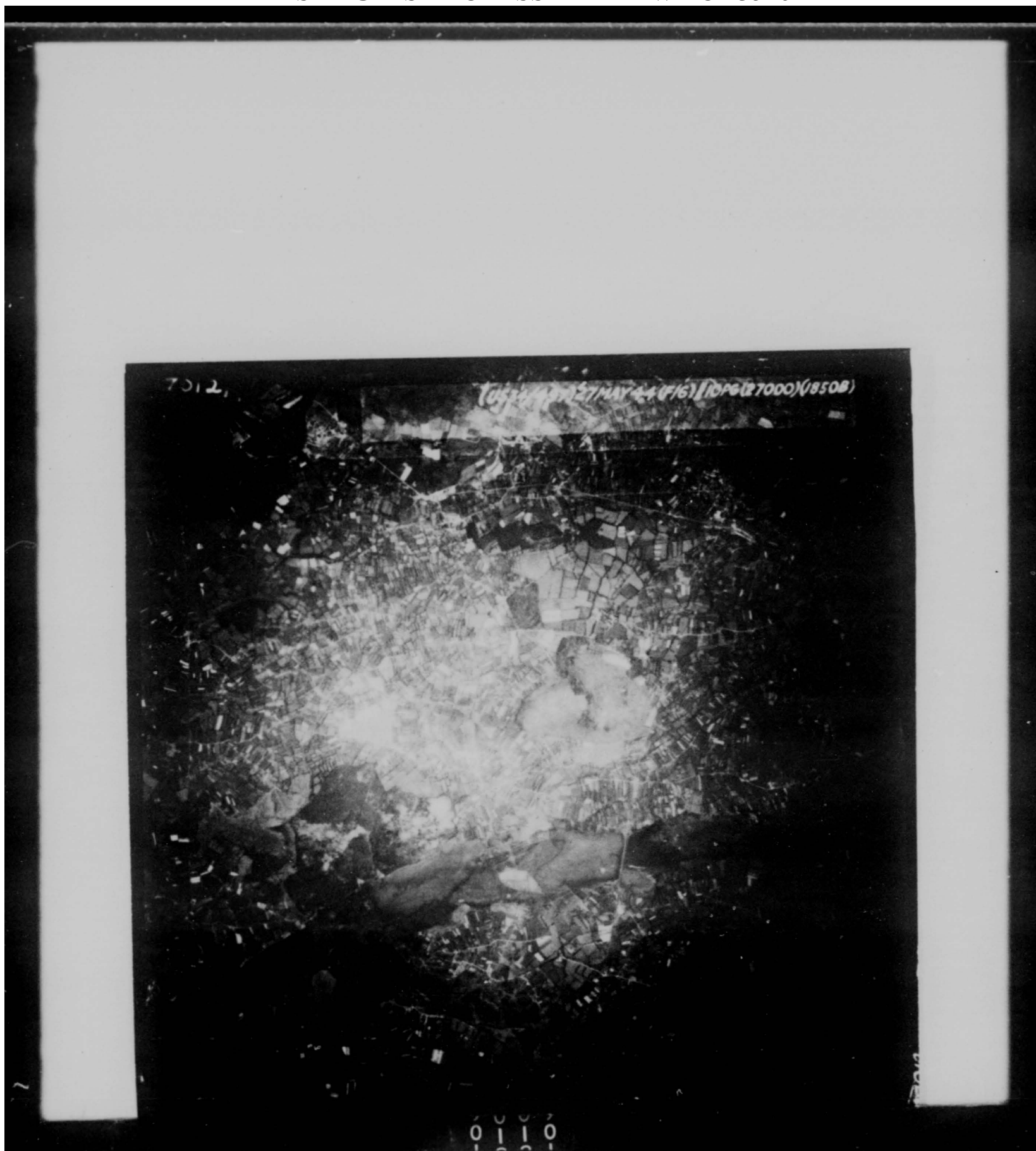



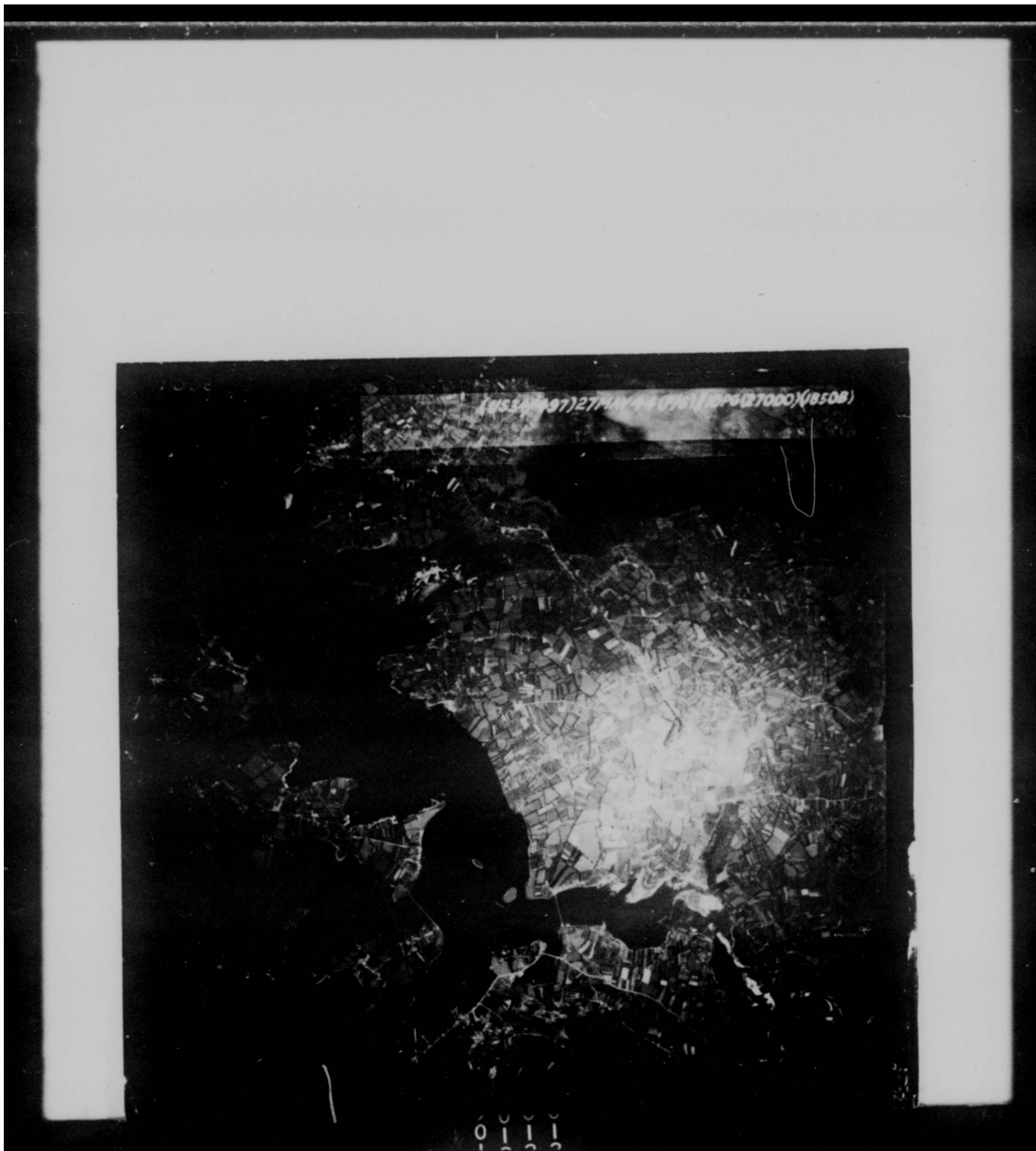

TOP SECRET  
BIGOT

TIS/CG/132/1

SUPPORT HEADQUARTERS  
ALLIED EXPEDITIONARY FORCE  
G-2 (LIVE LIGHTS) DIVISION

TOP SECRET

Copy 101

31 May 1944

NEPTUNE ARGUS NO: 34

With this Report:

- Appendix 'A' - Artillery
- Appendix 'E' - Obstacles
- Appendix 'F' - Minefields
- Appendix 'H' - P.O.L. Dumps
- Appendix 'I' - Signal Installations

Offshore Mining

1. It is reliably reported that the Germans are laying defensive mines of a new type, chiefly in depths of two or three fathoms at L.W.S. Reconnaissance photographs show the mines to be cylindrical, about 4 ft 6 in long and 2 ft 9 in in diameter. They are possibly ground mines of simple construction and may have snag lines. They are likely to be found in all areas.

These mines are of course distinct from beach mines above L.W.M. which have so far been reported in NEPTUNE ARGUS.

New list of Batteries in the NEPTUNE AREA

2. Issued with this report is a list of active battery positions between ST VALERY-EN-CAMX and CHERBOURG inclusive. This text is similar in form and contents to those previously issued in TIS Dossiers, except that it does NOT include dummy and abandoned positions. It is based on information received up to 27 May 44 and includes brief notes on bomb damage where necessary.

Secret Weapon Sites

3. Part II of Appendix 'A' to this report contains a list of known secret weapon sites in the NEPTUNE area. The older sites already appear on overprinted defence maps with the symbol "WK". Since the publication of these maps several new sites have appeared, and the number is still increasing. These installations are NOT organised as strongpoints.

"Ammunition Dump" at ENNEBRDEVILLE

4. Reference Map: GGGS 4347, Sheet 31/22SW, 1024

Further to NEPTUNE ARGUS No. 29, Appendix G, paragraph 5, new photographs of this installation reveal details of construction hitherto concealed by camouflage. At 10752464 there is a large concrete building which is unidentified but appears to have certain affinities with Secret Weapon sites. The remainder of the site is as described in previous reports. This has always been regarded as an unusual site for an ordinary ammunition dump.

CONFIDENTIAL

Sortie 1060 606, 4094 - 5

TOP SECRET  
BIGOT

1534

/5.....

0 1 1 2

TOP SECRET  
BIGOTConcrete boxes in the MONTAIGNE area

Ref Map: G.S.G.S. 4347/40/18 SE

Ref para 3 of N.A. 18, dated 15 May 44. Of the seven groups of concrete boxes or blocks reported from air cover of 14 May, groups 2, 3, and 4 are no longer seen on air cover of 29 May. The other four groups of blocks are not covered by the latest sortie.

Air Cover Sortie: 16/334 of 29 May 44.Comment:

The most likely explanation that the blocks are now dispersed on the beach nearby. Although they do not appear on the photographs, which were taken at low water, they may well be on the beach, since many of the known underwater obstacles are either barely visible or can not be seen at all.

"Small pits" in the NEPTUNE area:

Ref Map: G.S.G.S. 4347 Sheet 28/20 SE

In the ANNE DE VAUVILLE area; lines of small pits 8 ft. across are seen along hedgerows near a beach strongpoint. There are about 55 of these pits in all, and also 6 larger pits 10 ft - 15 ft across, nearby. The significance of these pits is unknown.

Air Cover Sortie: 140/207 of 28 May 44. Photo 4029.Comment:

Although these works appear unimportant in their present state, attention is drawn to them in view of the sudden appearance on recent air cover of similar pits in many localities near the coast, both in the NEPTUNE area and outside it. They have not been explained so far either from their individual siting or in relation to existing beach defences or lines of field works inland. Compare Neptune Argus No. 55 para. 2.

Rafts and Concrete Boxes.

A few more of these obstacles have been seen in the area of LUC-SUR-MER (See tracing attached)

CONFUSION.

Appendix C, para. 1, Neptune Argus No. 55, Map reference should read 1715 7930.

Para. 1 (v) Amend Sortie to read US 34/496.

*Spencer Lebedon*  
for *Capt G45*  
Major-General,  
A.C. of S.  
G-2.

TOP SECRET  
BIGOT

0 1 1 3





TOP-SECRET  
BIGOT

II. Other Reports.

1. ST. FROMOND

Ref. Map: GSGS 4250/6F2/523753

Perimeter wire has been installed around the railroad spur here. Weapon pits and dugouts are under construction.

Air Cover: Sortie 106G/517  
of 27 May 1944

Photo Nos. 4070-1

Comment:

Whatever may be the future of this site, it appears at the present to be nothing more than a strongpoint.

2. BEUVILLE

Ref. Map: GSGS 4250/7F1/065756

Four "guns" are seen here in circular pits. Lack of track activity suggests that this is a dummy position.

Air Cover: Sortie 400/170  
of 27 May 1944

3. COFONTAINE

Ref. Map: GSGS 4250/6E1/336252

A dummy battery is seen here, with emplacements 14-15 feet in diameter, 33-54 yards apart. To the rear is a double line of small pits.

Air Cover: Sortie 16/244  
of 22 May 1944

Photo Nos. 3038-9

Comment:

There appears to be no genuine battery in the area with which this dummy could be associated.

4. GATEVILLE

Ref. Map: GSGS 4250/6E1/392276

Excellent cover shows the following situation at this battery:

Nos. 1 and 2 emplacements are occupied, with guns camouflaged. No. 3 emplacement is still occupied. Nos. 4, 5, and 6 are unoccupied. The four casemates are complete, and to the rear of No. 2 casemate a gun is visible, limbered-up, in the process of being towed into the casemate.

Air Cover: Sortie 4/145  
of 30 May 1944

Photo No. 3008-9

5. AZEVILLE II

Ref. Map: GSGS 4250/6E3 & 4/363017

All four emplacements of this field battery are occupied. The dummy at 352012 (LE BISSON) is occupied by four dummy guns.

Air Cover: Sortie 106G/455  
of 22 May 1944

Photo Nos. 3125-6-7

TOP SECRET  
BIGOT

II. Other Reports.

1. ST. FROMOND

Ref. Map: GSGS 4250/6F2/523753

Perimeter wire has been installed around the railroad spur here. Weapon pits and dugouts are under construction.

Air Cover: Sortie 106G/517  
of 27 May 1944

Photo Nos. 4070-1

Comment:

Whatever may be the future of this site, it appears at the present to be nothing more than a strongpoint.

2. BEUVILLE

Ref. Map: GSGS 4250/7F1/065756

Four "guns" are seen here in circular pits. Lack of track activity suggests that this is a dummy position.

Air Cover: Sortie 400/170  
of 27 May 1944

3. GORONTAINE

Ref. Map: GSGS 4250/6E1/336252

A dummy battery is seen here, with emplacements 14-15 feet in diameter, 33-54 yards apart. To the rear is a double line of small pits.

Air Cover: Sortie 16/244  
of 22 May 1944

Photo Nos. 3038-9

Comment:

There appears to be no genuine battery in the area with which this dummy could be associated.

4. GATTEVILLE

Ref. Map: GSGS 4250/6E1/392276

Excellent cover shows the following situation at this battery:

Nos. 1 and 2 emplacements are occupied, with guns camouflaged. No. 3 emplacement is still occupied. Nos. 4, 5, and 6 are unoccupied. The four casemates are complete, and to the rear of No. 2 casemate a gun is visible, limbered-up, in the process of being towed into the casemate.

Air Cover: Sortie 4/145  
of 30 May 1944

Photo No. 3008-9

5. AEEVILLE II

Ref. Map: GSGS 4250/6E3 & 4/363017

All four emplacements of this field battery are occupied. The dummy at 352012 (LE BISSON) is occupied by four dummy guns.

Air Cover: Sortie 106G/455  
of 22 May 1944

Photo Nos. 3125-6-7

6.

Ref. Map: GSGS 4250/6E1/39462751

To the East of GATTEVILLE battery (392276) a split trail gun is seen in an emplacement 22 feet in diameter on top of a sunken shelter.

Air Cover: Sortie 4/145  
of 30 May 1944

Photo Nos. 3004, 3025

Comment:

TOP SECRET  
BIGOT

This gun is undoubtedly part of the secondary armament of GATTEVILLE battery. This position has been previously

TOP SECRET  
BIGOT

- 3 -

annotated on defence overprints as "possible range finder".

7. PLACE-MOUNTAIN Ref. Map: G333 4250/785/972808

Only No. 4 emplacement is occupied at this four-gun field troop.

Air Cover: Bertie 406/182 Photo No.: 3278-9  
of 30 May 1964

/III. Secret Weapon Sites.---

TOP SECRET  
BIGOT

0117

## BIGOT

- 4 -

III. Secret Weapon Sites

The following is a list of all the known secret weapon sites (Vergeltungsaffe) in the MANCHE and CALVADOS. Construction has been proceeding rapidly on new sites during the past few months. References are to the CGCS 4250 series of maps.

## CHERBOURG AREA

Location	Reference
BELBOSCHIN	5E2/104219
EPINEY FERRE	5E2/041234
HALLAU AU SAGE	6E3/168148
LES FONTAINES	5E4/072095
RAUVILLE LA BIGOT	5E4/086103
VAUVICARD	5E4/083084
MARGOT	6E5/176995
LE QUEENCOY	6E5/203994
L'EPINETTE	5E2/999228
GROSVILLE	5E4/046084
PIQUET	6E5/146988
LA GRANDE MAISON	5E4/061124
LES PASSES	6E3/222163
LA LANDE	6E3/214073
CAIETS	5E6/110947
LE MANOIR	5E2/066240
VAUGOURT	6E3/253127
BREUVILLE	5E4/106125
PLOTTENVILLE	5E2/068222
"	5E2/088215
BRISTELLERIE	5E4/117168
HARDINVAST	6E3/129173
LA GANCIERIE	6E3/184179
LA SORHELLERIE	6E3/181154
"	6E3/195164
MERNIL AU VAL	6E3/214175

## CALVADOS and EURE

LA COURRIERE	8P1/493090
LA PREE	8P2/910992
LE PETIT BOISSEY	8P2/859864
HOTNOT	7P1/806664
CHAIRONDE FERRE	7P1/811717
CHATEAU DE BELMONT	6E6/601911
SIE. CROIX SUR MER	7E5/932846
VER SUR MER	7E5/931045

G-2 (Intelligence) Division,  
 SHLEF.  
 31 May 1944.

TOP SECRET  
 BIGOT

0 1 1 8

TOP SECRET  
BIGOT

TOP SECRET.

APPENDIX 'E' TO NEPTUNE AREA NO. 3.  
Dated 31 May 1944.OBSTACLES IN THE NEPTUNE AREA.Underwater Obstacles.

- 1.
- PORT DE QUERQUEVILLE.
- Reference Map: G.S.G.S. 4347/31/22 SW.

Two uneven rows of obstacles, probably hedgehogs, run from 101263 to 103267.

Air Cover: Sortie: 16/339 Photo No: 4023  
of 30 May 44.

- 2.
- ST. PAIR-SUR-LES.
- Reference Map: G.S.G.S. 4347/31/12 NW & SW.

The stretch of obstacles previously reported between 127306 and 127290 now extends to 128299. The row of obstacles previously reported between 128307 and 128312 has been removed. A single row of obstacles, probably stakes, runs from 128307 to 128293.

Air Cover: Sortie: 140/130 Photo Nos: 4200-1  
of 25 May 44.  
(NOT received by T.I.S.)

- 3.
- BOUILLOL.
- Reference Map: G.S.G.S. 4347/31/12 SW.

The row of obstacles previously reported between 128267 and 128274 has been removed. A single row of obstacles, probably stakes, runs from 128255 to 128265. A short stretch of steel obstacles runs from 128255 to 128253.

Air Cover: Sortie: 140/130 Photo Nos: 4204-3  
of 25 May 44.  
(NOT received by T.I.S.)G-2 (Intelligence) Division,  
SMEP  
31 May 1944

CONFIDENTIAL

APPROVED FOR RELEASE BY NSA ON 08-28-2013  
95A/cTOP SECRET  
BIGOT

0119



TOP SECRET  
BIGOT

Issued with Appendix E to NEPTUNE ANGUS NO. 34  
dated 31 May 44

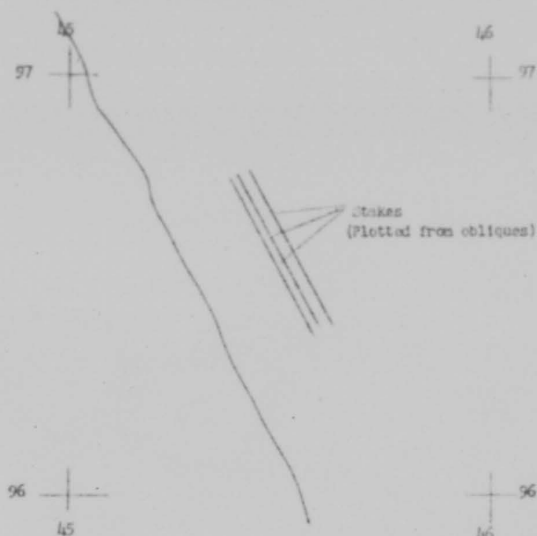

The information below is additional to that shown on the tracing issued in the NEPTUNE ANGUS NO 15  
Serial 27/28 of 24 May 44.

G.S.C.S. 4490 Sheet 74, AUCKLAND-A-18-18-18  
1:12,500

G.S.C.S. 4490 Sheet 84, BERNIERIS  
1:12,500

The information below is additional to that shown on the tracing issued in the NEPTUNE ANGUS NO. 30,  
Serial 100/102 of 30 May 1944.

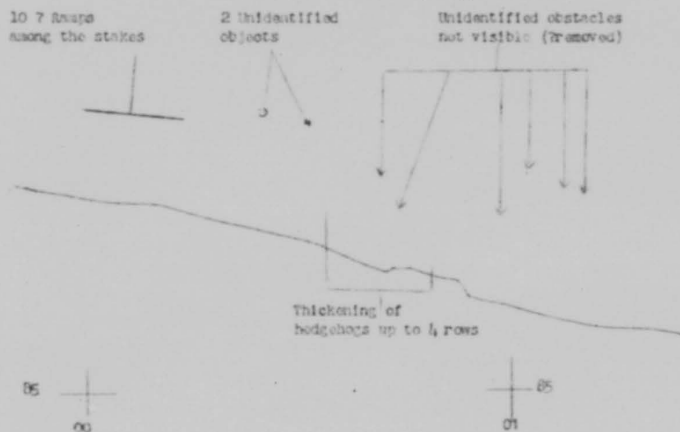

G-2 (Intelligence) Division,  
CHAC,  
31 May 1944.

TOP SECRET  
BIGOT

0 1 2 0

TOP SECRET  
BIGOT

Issued with Appendix E to SEPTEMBER 1954, No. 34  
dated 31 May 1954

0-2 (Intelligence) Division  
Sheet 86 COUNTRYMAN  
1:12,500 Tracing "A" (Cont)

This tracing supersedes all previous  
tracings and tracings of this map sheet.

Article 600/102 of 30 May 1954.

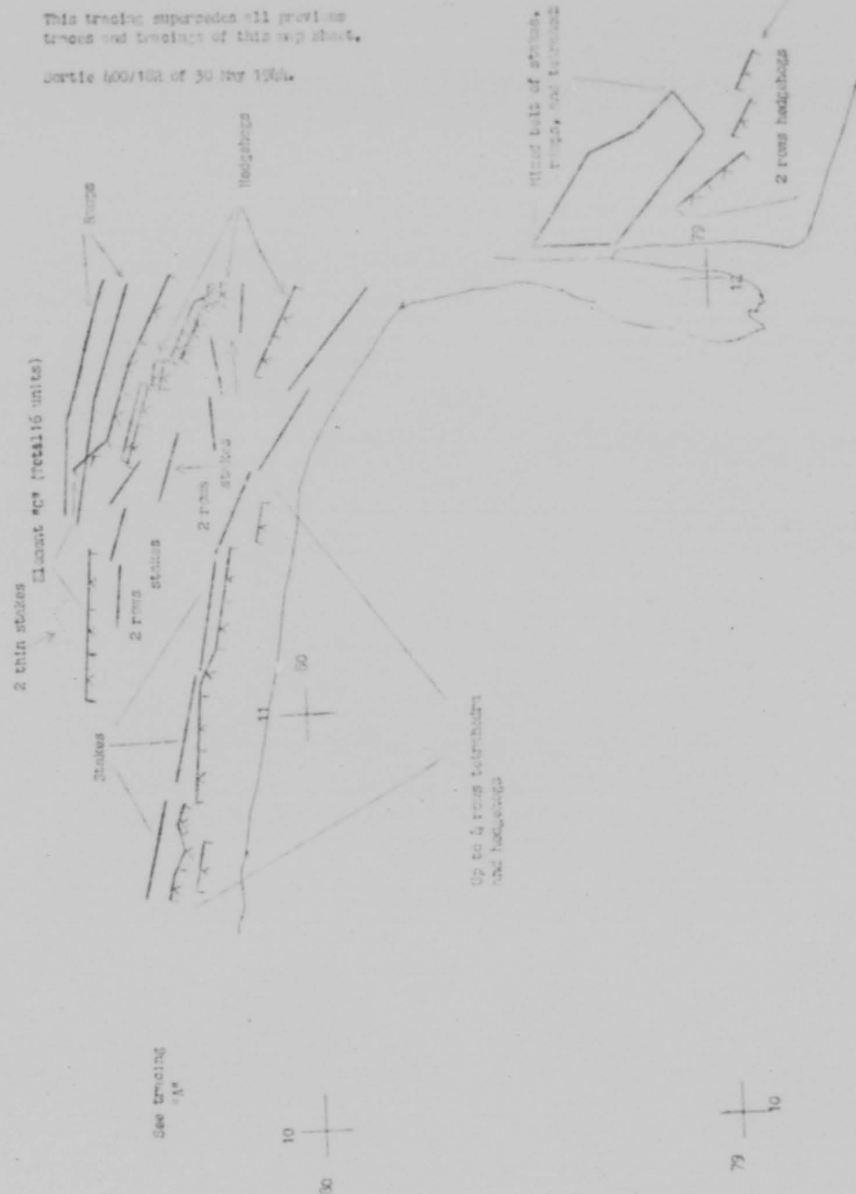

0-2 (Intelligence) Division,  
SHAFF  
31 May 1954

TOP SECRET  
BIGOT

0 1 2 1

TOP SECRET  
BIGOT

The information below is additional to that shown on the  
tracking, issued in the REPORT AUCID NO. 7.  
Date 100/132 of 30 May 1944.

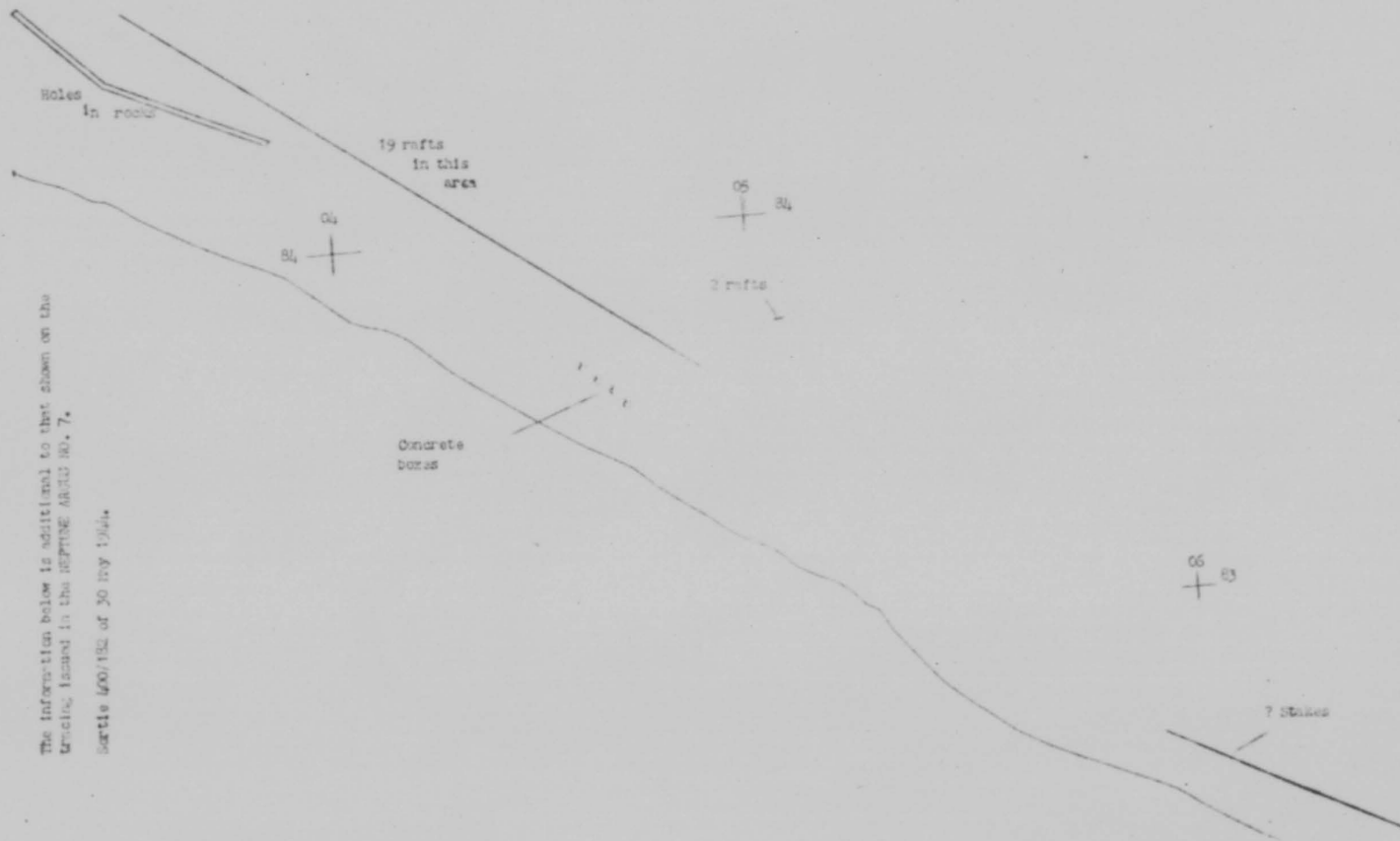

O-2 (Intelligence) Division  
31 May 1944

TOP SECRET  
BIGOT

0 1 2 2

TOP SECRET  
BIGOT

45

+ 99

98

44

Stakes for fish nets.

Issued with Appendix E to NEPTUNE ARGUS NO. 34, dated 31 May 1944.

G.S.G.S. 4490. Sheet 75 POUCAUVILLE 1/12,500

The information above is additional to that shown on the tracing issued in the NEPTUNE ARGUS NO. 28.

Air Cover \_\_\_\_\_ Sortie 2/63 of 24 May 44.

TOP SECRET  
BIGOT

0 1 2 3

TOP SECRET  
BIGOT

Issued with Appendix E to REPORTS ACTS NO 56  
Dated 31 MAY 1954

G.S. Sub. 6000 sheet 06  
SHEET NO. 1110, 500  
R. 10110. 11. 1954

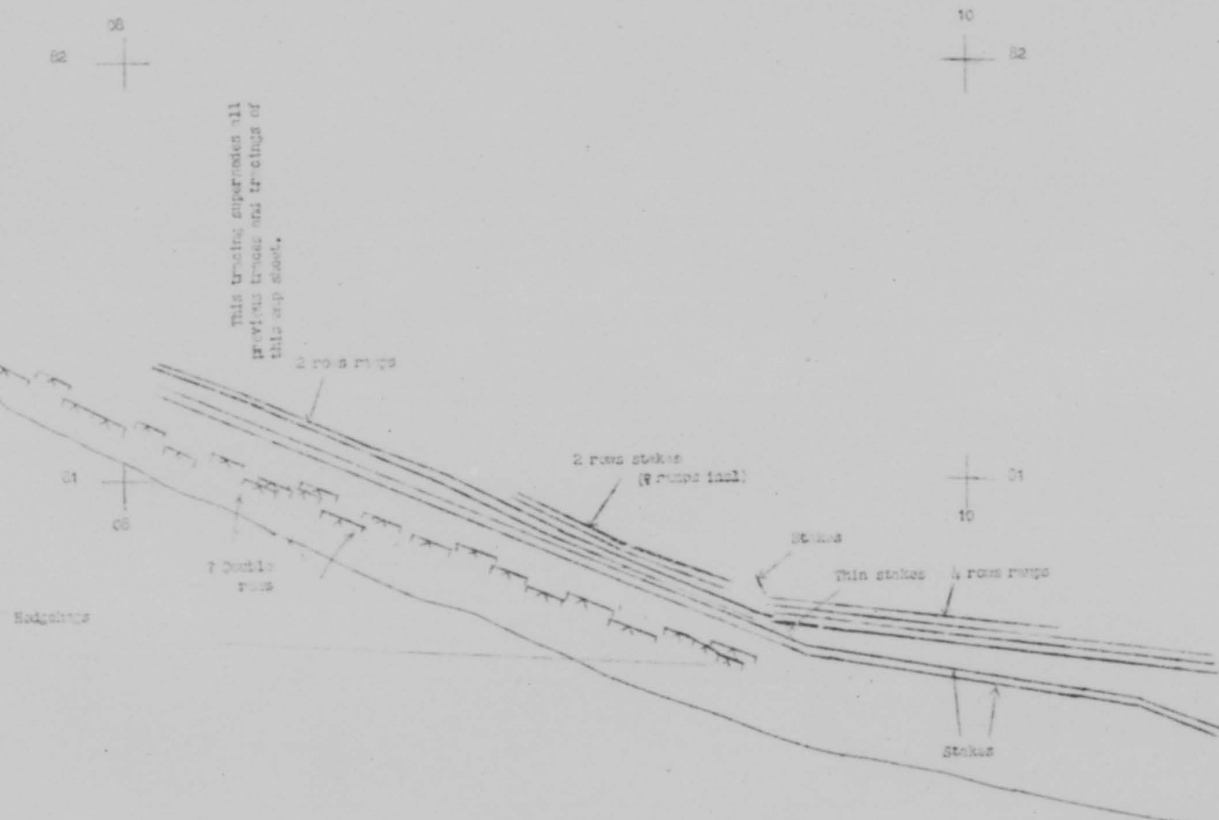

This trench supercedes all previous trench and tracings of this type sheet.

TOP SECRET  
BIGOT

Gen (Intelligence) Division  
31 May 1954

0124

TOP SECRET  
BIGOT

TOP SECRET

APPENDIX 'F' TO NEPTUNE ARGUS NO. 34  
Dated 31 May '44Minefields in the NEPTUNE Area.

1. MONT CANISY Ref. Map: 4347/43/18 SW  
On the seaward slopes of the MONT CANISY mines have been detonated by recent bombing, in the area enclosed by 423113, 423111, 420112, 420110.  
Air Cover: Sortie 140/157 Photo Nos. 4045-6  
of 22 May 44
  
2. MONT CANISY Ref. Map: 4347/43/18 SW  
New minefields have been laid in fields on the S.W. side of MONT CANISY, in the area enclosed by 421104, 420105, 418104, and 419102. The mines are in belts of 6 - 8 rows.  
Air Cover: Sortie 140/157 Photo Nos. 3061-2  
of 22 May 44
  
3. BENERVILLE Ref. Map: 4347/43/18 SW  
In the gardens of houses at BENERVILLE, between 41471064 and 41271057, a number of mines have been exploded by sympathetic detonation during a recent bombing attack in the area.  
Air Cover: Sortie 140/157 Photo Nos. 4047-8  
of 22 May 44
  
4. DIVES-SUR-MER Ref. Map: 4347/40/16 NE  
A minefield is being laid, N.E. of DIVES, at 236796. Two belts are completed; and work is still proceeding on two others. All four have eight rows with mines 10 feet apart.  
Air Cover: Sortie 140/157 Photo Nos. 4066-7  
of 22 May 44
  
5. DIVES-SUR-MER Ref. Map: 4347/40/16 NE  
A new minebelt has been laid at 23777945 containing eight rows with mines 10 feet apart. There are now five belts in all in this area. See above.  
Air Cover: Sortie 16/259 Photo Nos. 4047-8  
of 24 May 44
  
6. LONGUES Ref. Map: 4347/37/18 SW  
There is a possible new belt of mines West of LONGUES between 79458729 and 79458738.  
Air Cover: Sortie 140/157 Photo Nos. 4145-6  
of 22 May 44

CONFIDENTIAL

TOP SECRET 77. ARROMANCHES

BIGOT

0 1 2 5



TOP SECRET  
-2-  
BIGOT7. ARROMANCHES

Ref. Map: 4347/37/18 SE &amp; SW

Date of Information: 15 March 44

All fields in the coastal area here are being mined. The local peasants are being conscripted to assist in this work.

Comment:

Extensive mining is confirmed in the region of ARROMANCHES and has been described in NEPTUNE ARGUS. Whether, however, this is the task for which the local peasants have been conscripted is uncertain. They are much more likely to have been employed in digging holes for anti-air-landing obstacles.

8. VIERVILLE-ST. PIERRE DU MONT

Ref. Map: 4347/34/18 NE

Date of Information: 4 May 44

An airman on visual air-recce saw floating mines "half submerged and forming a pattern" off-shore between VIERVILLE 6591 and ST. PIERRE DU MONT 6094.

Comment:

No floating mines can be seen on Sortie 400/103 dated 11 May 44, which gives good cover for a distance of about 2,000 yards from the coast, or on Sortie 400/34 dated 23 May. The mines seen by the airman may have been totally submerged.

9. COLLEVILLE-SUR-MER

Ref. Map: 4347/34/18 SE

There is a minebelt 6 rows deep and 390 feet long at the end of the anti-tank ditch between COLLEVILLE and ST. LAURENT.

Air Cover: Sortie 140/157  
of 22 May 44

10. TOURLAVILLE

Ref. Map: 4347/31/22 SW

West of the important battery strongpoint at 188236 N.E. of TOURLAVILLE is a fairly extensive mined area. Mines can be seen from 18252380, along the face of the cliff as far as the wire belt at 18552371. From this point they follow the wire to 18622345 and then the road as far as 18252380 via 18302356. On present cover the belts cannot be distinguished clearly enough for accurate plotting.

Air Cover: Sortie 16/244  
of 22 May 44

Photo Nos. 4066-711. CAP LEVY

Ref. Map: GSGS 4347 Sheet 31/22 SW

Date of Information: December 43

A fair source reports that mines were laid in December 1943 round the abandoned fort near CAP LEVY - 248282.

Air Cover: Sortie 1064/373  
of 11 April 44

Photo Nos. 4084-5Comment:

Presence of mines here confirmed.

TOP SECRET  
BIGOT12. EAST COTENTIN

0 1 2 6

TOP SECRET  
BIGOT

-3-

12. EAST COUERTIN

Ref. Map: 4347/31/20 SE

Recent air cover shows mines on the East coast of the OBERBOURG peninsula at two places where, hitherto, their presence had only been suspected.

- (a) South of FORT ST MARCOUF, at 394054 where a minebelt 60 yards in length can be distinguished.
- (b) Between QUINEVILLE and AUMEVILLE LESTRE at 36750992. The minebelt is at least 100 yards in length.

Air Cover: Sortie 16/277  
of 19 May 44

Photo Nos. 4026 and 4029

13. LA RUE

Ref. Map: 4347/28/22 Composite

A minebelt, possibly containing four rows, has been laid between LA RUE and VANVILLE from 976243 to 976237.

Air Cover: Sortie 1066/518  
of 27 May 44

Photo No. 4229

14. HOULGATE

Ref. Map: 4347/40/18 SE

The most recent air cover of the area shows a minebelt about 100 yards in length, South of HOULGATE between 24008035 and 24028025. The belt contains eight rows 20 feet apart with mines 10 feet apart.

Air Cover: Sortie 16/334  
of 29 May 44

Photo Nos. 3159-60

15. HONFLEUR-ISIGNY

Date of Information: 29 Feb. 44

A good source reports that between HONFLEUR and ISIGNY the coast is mined to a depth of 100 to 200 metres, except at OUISTREHAM where minefields extend to a depth of 2000 metres.

Comment:

Air cover does NOT confirm the continuous mining of the coast implied in this report, but it is NOT unlikely that mining may be more extensive than air photography is able to reveal. The figure given for OUISTREHAM is, however, thought to be wrong. Elsewhere in this area, of course, minefields extend to a depth of considerably more than 200 metres from the coast.

16. BENERVILLE

Ref. Map: 4347/43/18 SW

Recent bombing of the BENERVILLE battery has caused further sympathetic detonation of mines nearby, this time N.E. of the battery where a minefield is now seen in the area bounded by 42501113, 42551120, 42571105.

Air Cover: Sortie 16/313  
of 28 May 44

Photo Nos. 4091-2

TOP SECRET

BIGOT

/17. ANSE DE VANVILLE

0 1 2 7

TOP SECRET  
BIGOT

17. ANSE DE VAUVILLE

Ref. Map: 4250/SE/2 & 5E/4

Date of Information: 22 May 44

The mines used on the coast of the ANSE DE VAUVILLE are reported to be of the wooden-box type.

18. CAP DE CARTHAGE

Ref. Map: 4347/26/18 NE

Date of Information: February 44

The CAP DE CARTHAGE is reported to be defended on its landward side by a minefield running continuously from the coastal belt at 95,950 to 006943.

Comment:

Though NOT confirmed by air photos, this report is probably true.

G-2 (Intelligence) Division,  
SHAEP.  
31 May 1944

TOP SECRET  
BIGOT

0 1 2 8

TOP SECRET  
BIGOT

TOP SECRET.

APPENDIX 'H' TO NEPTUNE ARGUS NO. 34.  
Dated 31 May 1944.Enemy P.O.L. Supplies and Depots in the NEPTUNE Area.

- 1.
- CAEN
- Reference Map: 4250/771.
- 
- (CALVADOS)

(1) There are petrol reserves:

- (a) at 046680 (in four tanks on COURS MONTALIVET along River CENE).
- (b) at 037679
- (c) at 035678

(2) There is a Tankstelle (petrol point) at CAEN.Air Cover: Sortie 400/157 of photo Nos: 3237-8 and 4242/3  
25 May 1944Date of Information: End of January 1944Comment:

- (1) (a) Air cover shows the tanks (one large, three small ones), but does not afford evidence of activity.
  - (b) and (c): Air cover does NOT confirm. However, the ground report is from a reliable source.
  - (b) Appears to be at or behind garage of the QUAI de JUILLET.
  - (c) Appears to be at or near a bus garage.
- (2) Probably the petrol point reported at 050674 (NEPTUNE ARGUS No. Appendix H, page 7, paragraph 8).

These new data might help, to a limited extent, to understand the important fuel traffic reported at CAEN (See NEPTUNE ARGUS No. 29, page 1, paragraph 1).

- 2.
- LE PLESCHE
- Reference Map: 4250/786.
- 
- (LORNE)

200 tank-lorries are parked at the PRITANEE. Several hundred infantrymen and G.T. men are there.

Air Cover: RA/501 covers area but is not available.Date of Information: End February 1944.Comment:

This is (or was) an exceptional concentration of P.O.L. bulk supply vehicles, reported by a usually reliable source. The PRITANEE (a XVII th century military school) is north of the town at 189032 with a large park at 189033.

- 3.
- BEAUMONT le ROGER
- Reference Map: 4250/894
- 
- (BURE)

(a) A petrol depot is being built at W.L. ST. MARTIN (9174), (one mile SW of BEAUMONT).

(b) (i)  
6 tank-waggon of petrol are kept on siding at 921765 (line PARIS-SVREUX). (NEPTUNE ARGUS NO. 15, Appendix H, Paragraph 5).(ii)  
A petrol depot is located in house 931779.(iii)  
There is an M.T. petrol point (one pump) at 927768.

/Air Cover: .....

DECLASSIFIED  
AUTH: LTR SHAW 27 JUN 45 BY 389.31-1  
FOUO: NSG SAC ACC. 9SPICCONFIDENTIAL TOP SECRET  
BIGOT

0 1 2 9

TOP SECRET  
BIGOT

- 2 -

Air Cover: Sortie 4/35 of  
2 May 1944.Photo Nos: 4027-30 and 3025-7Date of Information: (a) February 1944.  
(b) January 1944.Comment:

SEARMENT-le-ROGER airfield is one mile NNE of the town (9378), in the vicinity of small woods. While therefore, (b) (i) and (b) (ii) are probably reserves for the G.F., it is possible that depot (a) is for the Army.

Air cover confirms (b) (i), but NOT the other items.  
Garage premises are seen at (b) (iii).  
The reports originate from very reliable sources.

4. BRICQUEBEC  
(BONCHE)Reference Map: 4250/584

Air cover shows that 118047 may have become a dump of some sort, between October 1942 and January 1944. Two vertical tanks (diameter 15') are seen beside the main buildings. It is near the station and served by a siding. Recent air cover does NOT show any change.

Air Cover: 1056/434 of  
19/5/44  
2/950 of  
4/1/44  
2/375 of  
20 Oct 42Photo Nos: 3227-8

3030

4081

Date of Information: 1944.Comment:

No ground information is available.

5. LISIEUX  
(CALVADOS)Reference Map: 8F1

- a) There is a German petrol point with 4 pumps on road R.N. 179 at 53588.
- b) There is a stock of FRENCH M.T. petrol (some 33,000 gallons) at the COMPAGNIE INDUSTRIELLE DES PETROLES, 31 Boulevard HERRET-FOURNET.

Air Cover: Sortie 4/34 of  
2 May 1944Photo Nos: 4093-5Date of Information: (a) End of Feb 44.  
(b) Beginning of  
April 44.Comment:

- a) A large building that could possibly be a garage is seen at the map reference given.  
A camouflaged building and a trench are visible at 535887.
- b) The Boulevard H.FOURNET is part of the same road R.N. 179. No other important FRENCH stocks are known in the CALVADOS.

Corrigendum: In NEPTUNE ARCUS NO. 20, Appendix H, Paragraph 1 line 4, the map reference of the CHAMPAGNE Station should read 490366.

G-2 (INTELLIGENCE) DIVISION  
SHAEP.  
31 May 1944.TOP SECRET  
BIGOT

0 1 3 0

TOP SECRET  
BIGOTAPPENDIX 'I' TO NEPTUNE ARGUS NO. 34  
Dated 31 May 1944.

TOP SECRET.

SIGNALS INSTALLATIONSA. Attacks on enemy radar stations from information up to 28 May 1943  
(This list supersedes Appendix 'I' to NEPTUNE ARGUS No. 31)

<u>No.</u>	<u>Place</u>	<u>Grid Reference</u>	<u>Details of Damage</u>
1.	OSTEND/DE HAAN	4040/20-732081	Chimney destroyed.
2.	CAP BLANC NEZ	4040/38-772759	South Westerly Giant-Wuerzburg temporarily unserviceable.
3.	CAP GRIS NEZ/BELLEVUE	4040/38-714683	1 Freya possibly damaged.
4.	BOULOGNE/MONUMENT	4040/49-685555	Chimney possibly damaged.
5.	ABBEVILLE/VAUGERICOURT	4250/5E2-571868	Chimney unusable.
6.	LE TREPORT/MONT HUON	4250/903-442813	Giant Wuerzburg destroyed.
7.	DIEPPE/CAUDECOTE	4250/905-208675	Hoarding partly damaged.
8.	ST. VALERIE EN CAUX	4250/8E6-992638	Easterly Freya believed direct hit.
9.	CAP D'ANTILIER	4250/8E1-547475 " " -006808	1 Freya possibly damaged. Chimney unserviceable for considerable period.
10.	CAEN/DOUVRES LA DELIVERANDE	4250/7E5-004800 " " -006808	1 Freya probably damaged. Chimney believed unserviceable.
11.	ARROMANCHES	4250/7E5-854865	Cannon strikes have probably rendered installations unserviceable.
12.	POINTE ET RAZ DE LA PERCEE	4250/6E6-623934	Pole type Freya destroyed.
13.	CHERBOURG/CAP LEVY	4250/6E1-254287	Cannon hits on Coast-Watcher.
14.	CHERBOURG/PERGANVILLE	4250/6E1-254257	1 Freya damaged, 1 Giant Wuerzburg possibly damaged, chimney unusable.
15.	OMONVILLE LA ROGUE/ ABCELIERS	4250/5E2-976312	Small hoarding damaged, large Coast Watcher hit by cannon fire.

CONFIDENTIAL

G-2 (INTELLIGENCE) DIVISION  
SHAEP.  
31 May 1944.TOP SECRET  
BIGOT

0 1 3 1





TOP-SECRET

ENEMY ARTILLERY IN THE NEPTUNE AREA

TOP SECRET

INFORMATION TO 25TH MAY, 1944.

Chart Ref. No.	Place	Ref. Map. S.S.C.S. 4250	Geographical co-ordinates		Category	No. of Guns	Particulars
P.1019	ST. VALERY EN CAUX	SD6/972642	49 52' 00"N.	00 43' 39"E.	M.C.B.	6	? 150 mm (5.9") K.16's. Range 24,000x. Practical rate of fire 2-4 r.p.m. Wt. of shell 113 lbs. Centre line N. Staggered line layout near beach. Open emps diam 37'. distance apart 95-110x. 4 CASEMATES u/c in May 1944. No. 4 concreted at 970646. Shelters and magazines in rear. Camouflaged with nets. Road serviced. One S/L near and in rear of guns. Sec.Arm: three 1t AA guns atop concrete shelters at 965646. Slight bomb damage in raid of 10th May 1944. No.6 emp demolished. Ident: Army Coast Tp. (25.5.44). No. 1, 2, 3, 4 occ.
P.1019	CRIQUEMANVILLE	8E1/039569	49 47' 26"N.	00 33' 12"E.	Pd.Tp.	? 4	? 105 mm (4.14") Pd.gun Howa. Range 13,000x. Practical rate of fire 6-8 r.p.m. Wt. of shell 33 lbs. Line layout. Open emps 22' diam. Rail served. Dummy at 839548. (9.5.44).
P.1019	CHAPELLE DE LA VIERGE, FOCALT	8E1/713556	49 46' 05"N.	00 22' 49"E.	M.C.B.	6	150 mm (5.9"). Range 24,000x. Practical rate of fire 2-4 r.p.m. Wt. of shell 113 lbs. Centre line NNW. Crescent layout on sea coast. Open circular emps 39' diam; 70-80x apart. 4 CASEMATES, 35' x 40', in front of emps 3, 4, 5 and 6; spaced 68-74x apart. CASEMATES Nos. 3 and 4 are complete, Nos. 1 and 2 not far beyond the excavation stage. Shelters near each emp, others in rear. Amn bunkers along road at 714554. Not camouflaged. Road serviced. B.C.P. on cliffs at 713558. Ident: An Army Coast Tp. Bomb damage to 12th May 1944 slight. Emps Nos 1 - 4 occ. No.5 unocc and damaged. No. 6 demolished. The two completed CASEMATES may be occupied. Both are probably occupied. (27.5.44).

Page 1.

TOP SECRET

0 1 3 3

TOP SECRET

TOP SECRET

Chart Map No.	Place	Ref. Map. G.S.G.S. 4250	Geographical co-ordinates		Category	No. of Guns	Particulars
F.1019	SENNEVILLE	8EL/731556	49 46' 10"N.	00 24' 20"E.	M.C.B.	6	150 mm (5.9"). Range 24,000x. Practical rate of fire 2-4 r.p.m. Wt. of shell 113 lbs. Centre line NNW. Staggered line layout near coast. Open circular emps; distance apart 55-110x, with six additional unocc emps built close to original six in April 1944. Concrete shelters and magazines in rear. Road serviced. BOP on edge of cliffs in front of bty. ? POP at 722562. Sec.Armt: two 20 mm AA guns. Ident: Army Coast Tp. Bomb damage to 8th May 1944: Five of the six original emps damaged, three very severely. Only Nos. 1 and 6 were occupied. (8.5.44).
F.1019	LA CAMPAINS	8EL/777554	49 46' 18"N.	00 28' 10"E.	Pd.Tp.	7 4	? 105 mm (4.14") Pd.gun Hows. Range 13,000x. Practical rate of fire 6-8 r.p.m. Wt. of shell 33 lbs. Crescent layout 3,300x inland. Centre line N. Open emps 26' diam; 32x apart. At least 3 emps occupied on 9th May 1944. (9.5.44).
F.1019	CLIQUEMARE	8EL/795558	49 46' 36"N.	00 29' 39"E.	Pd.Tp.	4	? 75 mm (2.95") Pd.guns. Range 13,000x. Practical rate of fire 6-8 r.p.m. Wt. of shell 13 lbs. Crescent layout 4,200x inland. Centre line N. Open emps 20' diam; 24x apart. Dazy at 793559. Probable mines to seaward side of bty. (3.5.44).
F.1019	GRAINVAL	8EL/683535	49 44' 46"N.	00 20' 28"E.	Dummy		Probably a dummy. Centre line NNE. Crescent layout. 4 open emps 33' diam; 33x apart. (28.4.44).
F.1019	MIQUETOT	8EL/731554	49 45' 14"N.	00 28' 40"E.	Pd.Tp.	7 4	? 105 mm (4.14") Pd. gun Hows. Range 13,000x. Practical rate of fire 6-8 r.p.m. Wt. of shell 33 lbs. Centre line NN. Crescent layout. Open emps 26' diam; spaced 34x apart. Heavily camouflaged. Possible mine belt around bty in 3 rows, 11' apart, with mines 11' apart. (3.5.44).
F.1019	CRIQUEMARE	8EL/687529	49 44' 30"N.	00 20' 57"E.	M.C.B.	6	? 150 mm (5.9"). Range 24,000x. Practical rate of fire 2-4 r.p.m. Wt. of shell 113 lbs. Centre line N. Irregular layout 70x inland. Open emps diam 40'; distance apart 40-70x. 5 large shelters behind emps. Some camouflage. Road serviced. NOTE: 9 emps, but only 6 are occupied. Possible anti-tank gun in emp to rear of bty. Bomb damage: negligible to 8th May 1944. (8.5.44).

Page 2.

TOP SECRET

0134

TOP-SECRET

TOP SECRET

Chart Map No.	Place	Ref.Map. G.S.G.S. 4250	Geographical co-ordinates		Category	No. of Guns	Particulars
F.1018	YPORT	SEL/656530	49 44' 21"N.	00 18' 21"E.	7 M.C.B.	7 4	? 150 mm (5.9") guns. Range 24,000x. Practical rate of fire 2-4 r.p.m. Wt. of shell 113 lbs. 4 CASEMATES still w/c at cliff edge. Ident: An Army Coast Tp. (28.4.44).
F.1018	LES HOGUES	SEL/657501	49 42' 51"N.	00 18' 36"E.	Pd.Tp.	4	105 mm L.P.H. 325 (f). (French gun-Howitzers). Range 11,200x. Rate of fire 4 r.p.m. Wt. of shell 34.5 lbs. (Armament reported as 2 x 105 gun Hows and 1 x 88). Centre line NW. Crescent layout 3,200x inland. Open emps diam 20'; 40-60x apart. One dugout shelter at each emp. Others in area. No camouflage. Road serviced. One unocc posn for S/L. Dummy at 652502. Ident: 3 Tp/Artillery Regt. 17 GAP Field Div. (22.4.44).
F.1018	PROBERVILLE	SEL/666504	49 43' 03"N.	00 19' 22"E.	Pd.Tp.	4	105 mm L.P.H. 325 (f). (French gun-Howitzers). Range 11,200x. Rate of fire 4 r.p.m. Wt. of shell 34.5 lbs. NOTE: ground source reports armt. as 2 x 105 gun Hows and 1 x 88 mm. Crescent layout 3,200x inland. Open emps diam 35'; 33x apart. 3 large shelters and a number of excavations in rear of guns. BOP central in front of posn. Dummies at 677498 and 663493. Ident: 2 Tp/Arty.Regt. 17 GAP Field Div. (8.5.44).
F.1018	CIX	SEL/687508	49 43' 20"N.	00 21' 07"E.	Pd.Tp.	4	? 105 mm (4.14") Pd.gun Hows. Range 13,000x. Practical rate of fire 6-8 r.p.m. Wt. of shell 33 lbs. (27.4.44).
F.1018	LES MARQUETS	SEL/693503	49 43' 06"N.	00 21' 38"E.	Pd.Tp.	4	105 mm L.P.H. 325 (f). (French gun-Howitzers). Range 11,200x. Rate of fire 4 r.p.m. Wt. of shell 34.5 lbs. NOTE: Source gives armt. as 3 x 105 mm, French gun-Hows. Centre line N. Crescent layout 4,225x from sea. Open emps diam 32'; 43x apart. 10 underground shelters, also several bunkers in front of guns. Construction continues. Camouflaged. Road serviced. Sec.Amt: three 20 mm AA guns. (28.4.44).
P.1018	LA MIAUTERIE	SEL/696508	49 43' 25"N.	00 21' 40"E.	Pd.Tp.	7 4	? 105 mm (4.14") Pd.gun Hows. Range 13,000x. Practical rate of fire 6-8 r.p.m. Wt. of shell 33 lbs. Centre line NW. 4 open emps 26'-29' diam; spaced 47x apart. 2 bunkers and shelter behind each emp. (21.2.44).

Page 3.

TOP SECRET

0135

TOP-SECRET

TOP SECRET

Chart Map No.	Place	Ref. Map G.S.G.S. 4250	Geographical co-ordinates	Category	No. of Guns	Particulars
P.1018	TOURVILLE	8E1/719499	49 43' 03"N. 00 23' 45"E.	Pd.Tp.	? 4	? 105 mm (4.14") Pd.gun Hows. Range 13,000x. Practical rate of fire 6-8 r.p.m. Wt. of shell 33 lbs. Open emps, diam 22". This may be only a prepared posn. (27.4.44).
P.1018	BIHOREL	8E1/664/94	49 42' 28"N. 00 19' 18"E.	Pd.Tp.	4	? 105 mm (4.14") Pd.gun Hows. Range 13,000x. Practical rate of fire 6-8 r.p.m. Wt. of shell 33 lbs. Guns in open circular emps. Dummy at 662493. (27.4.44).
P.1018	BARVILLE	8E1/648497	49 42' 33"N. 00 17' 55"E.	Pd.Tp.		Centre line NW. 4 unocc emps 35' diam; spaced 25-30x apart. Road and rail serviced. (30.4.44).
P.1018	PIMONT	8E1/575470	49 40' 42"N. 00 12' 07"E.	? Med.Tp. (Hows.)	4	? 150 mm (5.9") Hows. Range 14,600x. Practical rate of fire about 5 r.p.m. Wt. of shell 96 lbs. Centre line W. Crescent layout 2,800x inland. Emps diam 35'; 60x apart. 3 are open circular, one is square. All are revetted. 4 or 5 underground shelters in rear of guns. Road serviced. Dummies at 579468, 584472 and 578463. Ident: Probably an Army Static Coast Tp. (5.4.44).
P.1018	MENTHEVILLE	8E1/720466	49 41' 16"N. 00 24' 11"E.	Pd.Tp.	4	? 105 mm (4.14") Pd.gun Hows. Range 13,000x. Practical rate of fire 6-8 r.p.m. Wt. of shell 33 lbs. Guns in open circular emps. Sec.Armt: 2 AA/ME. Possible 3 gun lt AA bty w/c. (27.4.44).
P.1018	OURSSEL	8E1/565452	49 39' 40"N. 00 11' 27"E.	Med.Tp. (Hows.)	4	? 150 mm (5.9") Hows. Range 14,600x. Practical rate of fire about 5 r.p.m. Wt. of shell 96 lbs. Centre line W. Crescent layout 2,800x inland. Open emps 30' sq., 70-80x apart. Underground shelters at each emp. Camouflaged. Road serviced. Bomb damage to 20th May 44; CP and three shelters demolished. No damage to guns. (24.5.44).
P.1018	BEAUREPAIRE	8E1/583457	49 40' 03"N. 00 12' 54"E.	? Med.Tp. (Hows.)	4	? 150 mm (5.9") Hows. Range 14,600x. Practical rate of fire about 5 r.p.m. Wt. of shell 96 lbs. Centre line NW. Crescent layout 6,640x inland. Open emps diam 40'. Several shelters and magazines in rear of and close to guns. Camouflaged. Road serviced. BOP 80x in front of posn. Sec.Armt: three 20 mm AA guns, located on each side and in rear of BOP. Dummies at 584472 and 595460. (28.4.44).

TOP-SECRET

Page 4.

0136

TOP-SECRET

TOP SECRET

Chart Map No.	Place	Ref. Map G.S.G.S. 4250	Geographical co-ordinates	Category No. of Guns	Particulars
P.1018	CUVERVILLE	8E1/626450	49 39' 54"N. 00 16' 30"E.	Pd.Tp. ? 3	? 105 mm (4.14") Pd.gun Hows. Range 13,000x. Practical rate of fire 6-8 r.p.m. Wt. of shell 33 lbs. Further details unknown. (27.4.44).
P.1018	STE MARIE AU BOSQ	8E1/580450	49 39' 39"N. 00 12' 42"E.	? Med.Tp. (Hows.)	Unocc emps for 4 guns, probably 150 mm (5.9") Hows. Centre line NW. Emps diam 35'; 37x apart. Personnel/arm shelters w/c. (28.3.44).
P.1018	BRUNEVILLE	8E1/558457	49 39' 56"N. 00 09' 46" E.	Pd.Tp. ? 2	? 105 mm (4.14") Pd.gun Hows. Range 13,000x. Practical rate of fire 6-8 r.p.m. Wt. of shell 33 lbs. Guns in emps 26' diam; 50x apart. 6 arm shelters in area. (28.4.44).
P.1018	BAIGNEVILLE	8E1/730487	49 42' 26"N. 00 24' 48"E.	Pd.Tp. 4	? 105 mm (4.14") Pd.gun Hows. Range 13,000x. Practical rate of fire 6-8 r.p.m. Wt. of shell 33 lbs. Open emps 30' diam. (28.4.44).
P.1018	BEAUMESNIL	7E4/8E3/562446	49 39' 22"N. 00 11' 12"E.	Pd.Tp. 4	? 105 mm (4.14") Pd.gun Hows. Range 13,000x. Practical rate of fire 6-8 r.p.m. Wt. of shell 33 lbs. Further details unknown. (8.5.44).
P.1018	CRETOT	7E4/8E3/677432	49 39' 13"N. 00 20' 50"E.	Med.Tp. ? 4	? 150 mm (5.9") Hows. Range 14,600x. Practical rate of fire about 5 r.p.m. Wt. of shell 96 lbs. Centre line N. Crescent layout. Open emps 33' diam; spaced 60x apart. 3 emps occupied on 11th April 1944. 3 small underground shelters in area. Additional accommodation in bldgs to NE. (11.4.44).
P.1017	LA CHEILLIERE	7E4/8E3/574386	49 36' 12"N. 00 12' 50"E.	Pd.Tp. ? 4	? 75 mm (2.95") Pd. guns. Range 13,000x. Practical rate of fire 6-8 r.p.m. Wt. of shell 13 lbs. Guns in open emps 18' diam. Centre line E. Probably 3 guns present on 8th May 1944. Probable alternate posn at 578382. (8.5.44).
P.1017	TURRETOT	7E4/8E3/586388	49 36' 22"N. 00 13' 45"E.	Pd.Tp. 4	? 105 mm (4.14") Pd.gun Hows. Range 13,000x. Practical rate of fire 6-8 r.p.m. Wt. of shell 33 lbs. Guns in open emps 24' diam. Centre line E. Possible alternate posn at 589382. (8.5.44).

TOP-SECRET

Page 5.

0137



TOP-SECRET

TOP SECRET

Chart Map No.	Place	Ref. Map G.S.G.S. 4250	Geographical co-ordinates		Category	No. of Guns	Particulars
P.1017	LE VAUSSUR	7B4/8B3/504367	49 35' 15"N.	00 13' 40"E.	Pd.Tp.	4	? 105 mm (4.14") Pd. gun Howa. Range 15,000x. Practical rate of fire 6-8 r.p.m. Wt. of shell 33 lbs. Open emps 30' diam. Dummy at 590366. (3.5.44).
P.1017	BOUQUEVILLE	7B4/8B3/493363	49 34' 34"N.	00 06' 42"E.	L.C.B.	4	105 mm (4.14") Coast guns, though possibly only gun-Howitzers. Range 19,000x. Practical rate of fire 6-8 r.p.m. Wt. of shell 33 lbs. Centre line W. Arc of fire ? 120-140°. Crescent layout near coast. Old open emps diam 30'; 100x apart. 4 CASEMATES 30' x 39' at 499362, 498363, 499361 and 499360. Nos. 1 and 3 complete on 11.4.44; 2 and 4 still u/c. On 6.5.44 original emps still occupied. 3 concrete shelters u/c. 5 shelters completed in woods to NW. Pom camouflaged. Road serviced. CP at 493363. Tall steel framework tower on solid concrete base centrally in rear of CASEMATES. Possibly an CP, or wireless station. Ident: Batterie MITE of 778 Army Coast Btn. Dummy at 501365. Possible alternate pom at 503367. (11.4.44).
P.1017	BRIERE	7B4/8B3/488350	49 35' 48"N.	00 05' 59"E.	? M.C.B.	4	? 150 mm (5.9"). Range 24,000x. Practical rate of fire 2-4 r.p.m. Wt. of shell 113 lbs. Centre line W. Bty in line 435x from coast. Open emps diam 38'; 42-55x apart; open in rear. Several shelters in rear hidden in trees. Very good natural camouflage. Road serviced. Ident: Batterie BRIERE, a troop of 778 Army Coast Btn. (28.4.44).
P.1017	LA CORVSE	7B4/8B3/464314	49 31' 42"N.	00 04' 10"E.	M.C.B.	3	? 170 mm (6.7") guns. Range 32,371x. Practical rate of fire about 1 r.p.m. Wt. of shell 150 lbs. Centre line NW. Arc of fire 120-140°. 3 open emps 44' diam; spaced 90-112x apart. 3 CASEMATES, 60' x 72' u/c at 467315, 466314 and 465313. No. 1 CASEMATE complete and occupied. Guns are 30' overall with trail ring, 32' in diam. ? CP u/c at 463309. Road serviced. (28.4.44).

Page 6.

TOP-SECRET

0138

TOP-SECRET

TOP SECRET

Chart Map No.	Place	Ref. Map G.S.G.S. 4250	Geographical co-ordinates	Category No. of Guns	Particulars
P.1017	LE GRAND CLOS	784/383/467307	49 31' 25"N. 00 04' 39"E.	M.C.B. 3	300 mm guns. Range at least 45,000x. Practical rate of fire 1 r.p.m. Wt. of shell ? 1,640 lbs. Centre line NW. Arc of fire ? 180°. CASEMATES, approx 120' x 180', w/c at 468306, 467307 and 466306. No. 1 has been completed and gun installed in turret. Overall length of turret and barrel approx 85' with gun projecting about 40' from turret. Served by road and rly. Bomb damage: This bty has been severely damaged in repeated bombings. The roads and ltrly serving the pom have been heavily damaged. It is possible that all work has been abandoned except on No. 1 CASEMATE, which may itself be unserviceable after direct hits on 9th May. A ground source reported the entire site as unserviceable after the raid of 10th April. (22.5.44).
P.1017	LA BORIE PEURINOT	784/383/500311	49 31' 42"N. 00 07' 18"E.	Pd.Tp. 4	? 105 mm (4.14") Pd. gun Hows. Range 13,000x. Practical rate of fire 6-8 r.p.m. Wt. of shell 33 lbs. Crescent layout sited NNE. Open emps 19' diam; 57-64x apart. Four CASEMATES facing NE w/c. Shelters and magazines in rear. Road ser. Dummy at 497313. NOTE: Bty NOT for coast defence. (19.4.44.)
P.1017	MONT'S TROTINS	784/383/500318	49 32' 11"N. 00 07' 52"E.	Pd.Tp. 4	? 105 mm (4.14") Pd. gun Hows. Range 13,000x. Practical rate of fire 6-8 r.p.m. Wt. of shell 33 lbs. Centre line N. Crescent layout 4,000x inland. Open emps about 30' diam; 50-55x apart. Four CASEMATES facing E w/c. No. 3 CASEMATE complete, probably occupied; emps 2,3,4 occupied; No.1 empty. 4 concrete shelters close by to E. Road serviced. Bty NOT for coast defence. Dummy at 513319. (19.4.44.)
P.1017	FONTAINE LA MALLET	784/383/525312	49 31' 57"N. 00 09' 18"E.	Dummy	Dummy pom for 4-gun Pd.Tp. Constructional activity seen in March 1944. Pom may become active. (9.3.44.)
P.1017	IGNAIVAL	784/383/459300	49 30' 57"N. 00 03' 59"E.	M.C.B. ? 4	? 150 mm (5.9"). Range 21,000x. Practical rate of fire 2-4 r.p.m. Wt. of shell 113 lbs. Centre line W. Arc of fire ? 150°. In line along sea coast. 4 concrete CASEMATES, 60' x 39', have been constructed, pinpointed at 461299 (2), 460298, 460297. Extensive M.O. in rear. Road serviced. ? 2 S/Ls. (19.4.44.)

TOP-SECRET

Page 7.

0139

TOP-SECRET

TOP SECRET

Chart MAP No.	Place	Ref.Map. S.S.U.S. 4250	Geographical co-ordinates	Category No. of Guns	Particulars
P.1017	LE HAVRE, CLIFFS	7E4/8E3/462308	49 31' 24"N. 00 04' 08"E.	1 L.C.B.	Unocc posn for 4-gun 7 L.C.B. All emps empty on 26.1.44. Centre line W. Bty in line behind beach. Open emps diam 32"; 70-100x apart. Shelters and magazines in area. Road serviced. (28.4.44).
P.1017	LA JAMBE LE BOIS	7E4/8E3/488305	49 31' 26"N. 00 06' 18"E.	Med.Ty. (How.) 4	7 150 mm (5.9") Hows. Range 14,600x. Practical rate of fire about 5 r.p.m. Wt. of shell 96 lbs. Centre line ENE. Staggered line layout 2,800x inland. Guns in open concrete emps 18' diam; with mountings 14' sq. 7 distance apart 45-55x. 7 4 concrete shelters with emps on roofs have been built to the rear. Four CASEMATES 32' sq. w/c in staggered line facing NE. On 19th May, 2 were still in excavation stage, other two not far advanced. Sec.Armt: two 20 mm AA guns. Darry at 493506.
P.1017	LA BORDE FREYRON II	7E4/8E3/498308	49 31' 34"N. 00 07' 06"E.	H.A.A.	Unocc posn for 6-gun 38 mm (3.46") H.A.A. Circle layout 4,400x inland. Revetted emps 19' sq; 60-100x apart. Dugout shelters at each emp. Road serviced. (28.4.44).
P.1017	LE CABARET	7E4/8E3/523302	49 31' 21"N. 00 09' 14"E.	Pd.Ty. 4	7 105 mm (4.14") Pd. gun Hows. Range 13,000x. Practical rate of fire 6-8 r.p.m. Wt. of shell 33 lbs. Crescent layout. Centre line W. Open concrete emps with 7 concrete bases 25' diam; trail ring 18' diam. Emps spaced 57-66x apart. Numerous small bunkers in rear. Larger huts and shelters further back generally east of the N flank. (26.1.44).
P.1017	CAP DE LA NEVE	7E4/8E3/461294	49 30' 58"N. 00 04' 12"E.	H.A.A. 7 6	7 88 mm (3.46") H.A.A. guns. Range 16,200x horizontal, 26,250' vertical. Practical rate of fire 15-20 r.p.m. Wt. of shell 20 lbs. Four guns forward; two staggered in rear. Open revetted emps diam 18"; 50-100x apart. Many shelters in area. One unocc 3/L posn. All six posns unocc 3.5.44. (3.5.44).
P.1017	BATTERIE DE LA NEVE	7E4/8E3/462294	49 30' 30"N. 00 04' 14"E.	7 L.C.B.	Unocc posn for 6-gun 7 L.C.B. Probably intended for 105 mm (4.14") Coast guns. Range 19,000x. Practical rate of fire 6-8 r.p.m. Wt. of shell 33 lbs. Centre line ESE. Emps in line on ramparts of old fort, near coast. Covered emps 25' sq; 30x apart. Shelters in bty area. Road serviced. Possibly occ. 10.4.44. (10.4.44).

TOP-SECRET

Page 8.

0140

TOP-SECRET

TOP SECRET

Chart Map No.	Place	Ref. Map. G.S.G.S. 4250	Geographical co-ordinates	Category	No. of Guns	Particulars
P.1017	LE NICE HAVRAIS	7B4/8E3/461293	49 40' 36"N. 00 04' 14"E.	L.C.B.	4	? 105 mm (4.14") Pl. gun Hows. Range 13,000x. Practical rate of fire 6-8 r.p.m. Wt. of shell 33 lbs. Centre line SW. Four CASERMATES. ? CP - CP w/c in centre. (10.4.44).
P.1017	HACIAL	7B4/8E3/497298	49 31' 04"N. 00 07' 08"E.	Pd.Tp.	4	? 105 mm (4.14") Pl. gun Hows. Range 13,000x. Practical rate of fire 6-8 r.p.m. Wt. of shell 33 lbs. Centre line NE. Open oval emps about 40' x 14'. (29.2.44).
P.1017	HAVRE - LES LANDES	7B4/8E3/537290	49 30' 52"N. 00 10' 30"E.	? Med.Tp. (Hows.)	4	? 150 mm (5.9") Hows. Range 14,600x. Practical rate of fire about 5 r.p.m. Wt. of shell 96 lbs. Centre line W. Crescent layout 8,000x inland. Open emps 35' diam; 63x apart. 2 shelters in centre line forward. Possibly a C.P. 2 excavations 40' x 50' for CASERMATES. Road serviced. ? Dummy at 554291. Sec.Armt: ? one 20 mm AA gun. (7.5.44).
P.1017	PALAIS DES REGATTES	7B4/8E3/465288	49 30' 22"N. 00 04' 33"E.	? M.C.B.	4	? 150 mm (5.9") guns. Range 24,000x. Practical rate of fire 2-4 r.p.m. Wt. of shell 113 lbs. Centre line SW. Bty in line near coast. Guns in circular concrete CASERMATES about 30' diam; spaced approx 100-110x apart. 3 completed and 4th almost finished. Road serviced. (23.12.43).
P.1017	BATTERIE DE L'EST	7B4/8E3/469285	49 30' 16"N. 00 04' 57"E.	? M.C.B.	4	? 150 mm (5.9") guns. Range 24,000x. Practical rate of fire 2-4 r.p.m. Wt. of shell 113 lbs. Guns in CASERMATES. Centre line SW. (18.4.44).
P.1017	PORT ST. AIGRESSE	7B4/8E3/478285	49 30' 18"N. 00 05' 42"E.	L.C.B.	? 4	? 105 mm (4.14") guns. Range 19,000x. Practical rate of fire 6-8 r.p.m. Wt. of shell 33 lbs. Centre line SSW. Arc of fire ? 120°. Open emps 38' diam on south rampart of old fort. 3 excavations on SW corner of fort in one of which a CASERMATE is nearing completion. One CASERMATE, 36' x 38', is complete 60x S of the main entrance. Ident: Batterie STE AIGRESSE of 266 Naval Coast Btn. Sec.Armt: three 20 mm AA guns. The guns were still in the open emps on 29.2.44. (29.2.44).

Page 9.

TOP SECRET

0 1 4 1

TOP-SECRET

TOP SECRET

Chart Map No.	Place	Ref.Map. G.S.G.S. 4250	Geographical co-ordinates	Category	No. of Guns	Particulars
P.1017	GRAVILLE WEST	7B4/8E3/522287	49 30' 36"N. 00 09' 18"E.	Fd.Tp.	4	7 105 mm (4.11") Fd.gun Howa. Range 13,000x. Practical rate of fire 6-8 r.p.m. Wt. of shell 33 lbs. Centre line W. Bty in line. Open emps diam 25'; 45-65x apart. Not camouflaged. Road serviced. (19.10.43).
P.1017	GRAVILLE	7B4/8E3/523285	49 30' 29"N. 00 09' 24"E.	Med.Tp. (Howa.)	4	7 150 mm (5.9") Howa. Range 14,600x. Practical rate of fire about 5 r.p.m. Wt. of shell 96 lbs. Centre line SW. Crescent layout. Open emps diam 32'; 50-65x apart. 2 shelters in rear of area and 2 more u/c. All heavily camouflaged. 4 new CASEMATES u/c to rear of original emps. Nos. 1 and 4, 27' x 35', are complete. Centre line of CASEMATES ENE. It thus appears that this bty is NOT for coastal defence. Road serviced. (9.4.44).
P.1017	HOCORINE	7B4/8E3/527284	49 30' 26"N. 00 09' 46"E.	7 Med.Tp. (Howa.)	4	7 150 mm (5.9") Howa. Range 14,600x. Practical rate of fire about 5 r.p.m. Wt. of shell 96 lbs. Centre line NE. Crescent layout 8,000x inland. Open emps diam 30'; 50-65x apart. One concrete shelter has been built in rear of area. 4 new CASEMATES u/c, in crescent layout, facing SW. No. 4, measuring 26' x 30' nearly complete; others still in excavation stage. Nos 2 and 3 forward of Nos. 1 and 4. It thus appears that this bty is NOT for coastal defence. Road serviced. (19.4.44).
P.1017	GRAINVAL	7B4/8E3/540281	49 30' 24"N. 00 10' 48"E.	H.A.A.	6	88 mm (3.46") H.A.A. guns. Range 16,200x horizontal, 26,250' vertical. Practical rate of fire 15-20 r.p.m. Wt. of shell 20 lbs. Circle layout 7,600x inland. Open sq. emps; 40-60x apart. 5 shelters in area of bty and work under way N of the bty. Road serviced. 2 unocc S/L posns. Sec.Armt: one 20 mm AA gun. (3.5.44).
P.1017	BATTERIE DES HUGUENOTS	7B4/8E3/476274	49 29' 36"N. 00 05' 38"E.	H.A.A.	6	88 mm (3.46") H.A.A. guns. Range 16,200x horizontal, 26,250' vertical. Practical rate of fire 15-20 r.p.m. Wt. of shell 20 lbs. Closed layout near coast. Sq. emps on the roofs of half-sunken concrete shelter type I/401. 1 concrete shelter completed. Sec.Armt: 3 lt AA guns. 1 S/L. (3.5.44).

Page 10.

TOP-SECRET

0142

TOP-SECRET

TOP SECRET

Chart Map No.	Place	Ref. Map. G. S. G. S. 4250	Geographical co-ordinates		Category	No. of Guns	Particulars
P.1017	HAVRE - PETITE RADE	784/883/474268	49 29' 18"N.	00 05' 28"E.	L.C.B.	2	? 75 mm (2.95") Pd.guns for close defence of harbour entrance, in open emps on end of jetty. Range 13,000x. Practical rate of fire 6-8 r.p.m. Wt. of shell 13 lbs. (15.1.44).
P.1017	LE HAVRE- PIERS	784/883/473265	49 29' 07"N.	00 05' 20"E.	? M.C.B.	2	? 150 mm (5.9") Pd.guns. Range ? 16,000x. For close defence of harbour entrance. In open emps on end of jetty. (15.1.44).
P.1017	FRONT DE LA FLORIE	784/883/483260	49 28' 58"N.	00 06' 18"E.	? M.C.B.	2	? 150 mm (5.9") guns on wheeled mountings. Range 16,000x. Centre line W. Arc of fire 120°. In line on end of pier. Guns in CASEMATES. Fire task: close defence of harbour entrance. Sec.Armt: one unocc 20 mm AA posn on tower at end of jetty. Ident: Naval Unit, known as Batterie NANNI. (21.3.44).
P.1017	DIGUE SUD	784/883/486252	49 28' 32"N.	00 06' 38"E.	M.C.B.	4	? 150 mm (5.9") guns. Range 24,000x. Practical rate of fire 2-4 r.p.m. Wt. of shell 113 lbs. Centre line WSW. Arc of fire ? 120°. 4 CASEMATES w/c approx 50' x 55'; spaced about 95x apart. Nos 1 and 2 nearly complete, No. 3 less advanced, No. 4 foundations laid. No guns yet seen on this site. (30.4.44).
P.1017	BASSIN DE LA MARÉE	784/883/498251	49 28' 32"N.	00 07' 37"E.	M.C.B.	2	? 150 mm (5.9") guns on wheeled mountings, for close defence of E-boat pens. Range ? 16,000x. Centre line W. Arc of fire ? 120°. 2 CASEMATES, 39' x 53' w/c; spaced 53x apart. 2 original open emps are occupied. Bty sited to cover the mouth of the river. (23.3.44).
P.1017	MOLE - CENTRAL	784/883/504250	49 28' 30"N.	00 08' 06"E.	H.A.A.	? 6	88 mm (3.45"). Range 16,200x horizontal, 26,250' vertical. Practical rate of fire 15-20 r.p.m. Wt. of shell 20 lbs. Emps on roofs of concrete shelters type 1/401; 50-100x apart. No camouflage. Road serviced. C.P. central. Sec.Armt: three 20 mm AA guns. All guns of this bty can fire on targets at sea. One emp unocc. (3.5.44).

Page 11.

TOP-SECRET

0 1 4 3



TOP-SECRET

TOP SECRET

Chart Map No.	Place	Ref.Map. G.S.G.S. 4250	Geographical co-ordinates		Category No. of Guns	Particulars
P.1017	SOUTH MOLE	784/823/498246	49 28' 16"N.	00 07' 39"E.	H.A.A. ? 4	88 mm (3.46") H.A.A. guns. Range 16,200x horizontal, 26,250' vertical. Practical rate of fire 15-20 r.p.m. Wt. of shell 20 lbs. Emgs in two staggered lines parallel to quay. Concrete emps 55-100x apart. Road serviced. C.P. central. Can engage targets at sea. All 4 emps probably unoco. (28.4.44)
P.544	ROCHER GODIN	885/655194	49 26' 17"N.	00 20' 30"E.	? L.C.B.	2 excavations, 39' x 51', for possible CASEMATES. Centre line W. 2 shelters 43' x 48' and one 37' x 73'. It is doubtful that this post can be considered a coastal bty. (28.4.44).
P.1017	PERNEDEPIE	885/530176	49 24' 41"N.	00 10' 52"E.	M.C.B. 3	? 155 mm (6.1") guns. Range 25,000x. Practical rate of fire about 2 r.p.m. Wt. of shell 95 lbs. Centre line NW. Arc of fire ? 120°. V layout, apex to the N. 3 CASEMATES, 45' x 43'; 70x apart. Concrete shelters w/c. Assn shelters to rear of CASEMATES. An infantry strongpoint SW of the post includes a shelter for an anti-tank gun, for which two open emps are provided. (20.4.44).
P.1017	DESERT L'AUBOUF	885/498130	49 22' 03"N.	00 08' 38"E.	M.C.B. (Howa.) 4	? 150 mm (5.9") Howa. Range 14,600x. Practical rate of fire about 5 r.p.m. Wt. of shell 96 lbs. Centre line NW. Crescent layout 5,280x inland. Open emps 38' diam; 42-70x apart. 1 shelter behind each emp. Road serviced. CP is central in rear of guns. Post camouflaged. ? one S/L east of S flank. Ident: Probably 27th Army Static Coast Tp. Sec.Armt: ? one 20 mm AA gun. Dummy at 497137. (22.1.44).
P.1017	DESERT DE TOUQUE	885/499107	49 20' 52"N.	00 08' 46"E.	? Pd.Tp.	Possible 4-gun Pd.Tp. w/c. (15.4.44).
P.1017	HEROQUEVILLE	786/473153	49 23' 06"N.	00 06' 24"E.	L.C.B. 4	? 105 mm (4.14") Pd. gun Howa. Range 13,000x. Practical rate of fire 6-8 r.p.m. Wt. of shell 33 lbs. Centre line WNW. Arc of fire 120°. Bty in line 600x inland. 4 CASEMATES w/c; 65-70x apart. Nos. 1, 2 and 4 appear completed, No. 3 well advanced. Possible CP - CP w/c between Nos. 2 and 3. Concrete shelters w/c, connected by probable underground concrete passage. Serviced by road and lt rly. (12.4.44).

Page 12.

TOP-SECRET

0144

TOP-SECRET

TOP SECRET

Chart Map No.	Place.	Ref.Map. G.S.S.S. 4250	Geographical co-ordinates	Category	No. of Guns	Particulars
P.1017	VILLERVILLE	786/486156	49 23' 21"N. 00 07' 26"E.	M.C.B.	6	155 mm (6.1") German guns. Range 25,000x. Practical rate of fire about 2 r.p.m. Wt. of shell 95 lbs. Centre line WNW. Arc of fire 7 1000. Guns in open circular concrete emps about 40' diam. Wheeled mountings, secured by shackles and stays to the central pivot of the emp. Emps 40-60x apart, sited in an arc facing west, 1,400x inland. Partly camouflaged. Road serviced. Underground concrete shelters and magazines throughout bty area; also a small number of huts in rear of posn. 4 CASEMATES w/c, 32' x 48'; 50-90x apart. No. 4 is almost complete, Nos. 1 - 3 not far beyond the excavation stage. The open emps are all occupied, with possible exception of No. 4. BOP in concrete and brick bldg. <sup>at 488156</sup> allocated. Dummy at 488154. Communications: buried cable, also wireless. Sec.Armt: probably two 20 mm AA guns (NOT located). Ident: 1 Tp. 510 Army Coast Btn. Bomb damage: negligible. (25.5.44.)
P.1017	VILLERVILLE II	786/493157	49 23' 30"N. 00 07' 59"E.	Pd.Tp.	4	7 105 mm (4.14") Pd. gun Hws. Range 13,000x. Practical rate of fire 6-8 r.p.m. Wt. of shell 33 lbs. Centre line N. Open irregular emps 18' diam, with a turning loop round each. Dummies at 494160 and 497146. (1.2.44.)
P.1017	CAILLERVILLE II	786/465141	49 22' 20"N. 00 05' 51"E.	Pd.Tp.	4	7 75 mm (2.95") Pd. guns. Range 13,000x. Rate of fire 6-8 r.p.m. Wt. of shell 13 lbs. Open emps. Bty sited to cover mouth of river at TRUVILLE from the E. It is NOT entirely certain that this is a genuine posn. (8.5.44.)
P.1017	CAILLERVILLE I	786/473141	49 22' 30"N. 00 05' 29"E.	Pd.Tp.	4	77 mm (3.04"). Range 11,700x. Practical rate of fire 8-10 r.p.m. Wt. of shell 13 1/2 lbs. Centre line W. Crescent layout. 2,000x inland. Open emps 28' diam; spaced 50-90x apart. Emps have parapets 7' thick, probably NOT concrete. Possible shelter in rear of each. Road serviced. CP 80x in rear of gun No. 3. Ident: 7 Div.Pd.Tp. Sec.Armt: two 20 mm AA guns. Dummy at 471141. (8.5.44.)

TOP-SECRET

Page 13.

0145

TOP SECRET

TOP SECRET

Chart Map No.	Place	Ref.Map. G.S.C.S. 4250	Geographical co-ordinates	Category No. of Guns	Particulars
P.1017	BRUYERS BOULLARD	786/478D.1	49 22' 32"N. 00 06' 52"E.	Med.Tp. (Howa.) 4	? 150 mm (5.9") Howa. Range 14,600x. Practical rate of fire about 5 r.p.m. Wt. of shell 96 lbs. Open circular pits, about 33' diam; 70x apart. Guns in an arc facing W, 2,250x inland. Partly camouflaged. Road serviced. Underground ? concrete shelters behind guns. Amn stacked along wire perimeter both in front and in rear of guns. Also a few huts. CP - unlocated. Communications: ? overhead cable, also wireless. Ident: ? Div.Med.Tp. Damages at 477145 and 477156. (3.5.44).
P.1017	LE MANOIR CHATSAU	786/485149	49 23' 00"N. 00 07' 22"E.	? Med.Tp. (Howa.) 4	? 150 mm (5.9") Howa. Range 14,600x. Practical rate of fire about 5 r.p.m. Wt. of shell 96 lbs. Open circular pits 37' diam; 100x apart. There are four emps sited in an arc facing N, and a fifth (alternative) W of No. 4. Underground shelters, probably NOT concrete, in rear of guns. CP unlocated. CP in underground shelter in centre of bty area. Communications: ? overhead cable. Damages at 482149 and 483145. (3.5.44).
P.1017	BENERVILLE	786/422107	49 20' 24"N. 00 02' 33"E.	M.C.B. 6	155 mm (6.1") guns. Range 25,000x. Practical rate of fire about 2 r.p.m. Wt. of shell 95 lbs. Centre line NNE. Arc of fire ? 180°. Crescent layout 225x from coast. Open concrete emps 52' diam; 40-50x apart. 4 CASEMATES, 30' x 45' w/c. These are of the "prefabricated type", with approx 7' of concrete filling between the inner and outer walls. Underground concrete shelters in rear; underground concrete magazines between gun emps. Some camouflage. Serviced by road and rly. NXP on cliff edge forward of the bty. Sec. Arm: three 20 mm AA guns 600x E of bty. Very strong infantry defenses. Ident: 2 Troop of 510 Army Coast Btn. Demy at 426110. Bomb Damage: Emps Nos. 4 and 5 slightly damaged. Only Nos. 1, 2 and 6 occupied. CASEMATE No. 1 has outer walls complete, internal construction proceeding. CASEMATES Nos. 2 and 3 appear complete. No. 4 is complete, but may have been slightly damaged by near misses. Nos. 3 and 4 have been strengthened by earth mounded up over the sides. (3.5.44).

TOP SECRET

0146

Page 14.

TOP SECRET

TOP SECRET

Chart Ref. No.	Place	Ref. Mar. G. S. I. S. 4250	Geographical co-ordinates	Category	No. of Guns	Particulars
F.1017	BLANVILLE	7E6/407006	49 19' 11"N. 00 01' 33"E.	Med. Tp. (Howa.)	4	? 150 mm (5.9") Howa. Range 14,500x. Practical rate of fire about 5 r.p.m. Wt. of shell 96 lbs. Centre line NW. Deep crescent layout 2,100x inland. Open emps diam 35'; 50-55x apart. 4 concrete shelters completed, one alongside each gun emp. Seven underground shelters nearby to W. Serviced by road and rly. ? CP central in front of posn. Sec.Armt: two 20 mm AA posns. Dummy at 403003. (3.5.44).
F.1017	CARRÉPOUR DU TRONG	7D6/266813	49 18' 24"N. 00 02' 48"W.	? Dummy		Four probable dummy guns in gun pits 33' sq; 25x apart, constructed in mid-May 1944. Probably another dummy for HOULGATE (256009). (15.5.44).
F.1017	POINTE LE CABOURG	7E6/223804	49 17' 51"N. 00 06' 21"W.	? L.C.B.	? 4	? 75 mm (2.95"). Range 12,600x. Rate of fire 3-10 r.p.m. Wt. of shell ? 13 lbs. (Only two guns present 29.1.44). In open emps on sea front facing N, diam 25'. Reconstruction in progress. Emps may be replaced by small CASSEATES. Concrete shelters ? type 502, partly underground, in rear. These guns are considered to be only the armament of an infantry strongpoint for beach defence only. (29.1.44).
F.1017	HOULGATE	7E6/256809	49 18' 12"N. 00 03' 37"W.	M.C.B.	6	155 mm (6.1") guns. Range 25,000x. Practical rate of fire about 2 r.p.m. Wt. of shell 95 lbs. Centre line NE. Arc of fire 180°. Guns staggered in line 700x from coast. Open emps diam 50'; 39-102x apart. Several underground concrete shelters and magazines in the area. 4 CASSEATES w/c, 32' x 48'; spaced 57x apart. The CASSEATES are of the "prefabricated type" with approx 7' of concrete between inner and outer walls. Nos. 3 and 4 are complete. BOP forward in the old semaphore stn and connected by cable. Ident: 3 Troop 510 Army Coast Btn. Sec.Armt: two or three 20 mm AA guns at bty, one or more near BOP. A probable new dummy is located at 251011 where 6 emps, 30' diam; 37-50x apart, have been built. Other dummies at 257012 and 256015. Bomb damage: Nos. 1 and 2 CASSEATES, in excavation stage, sustained direct hits. Nos. 3 and 4 CASSEATES are complete, and have possibly been damaged by near misses. They may be occ. No attempt has been made to repair them or to continue construction of the six open emps. 3 were demolished, 3

TOP SECRET

0147

TOP-SECRET

TOP SECRET

Chart Map No.	Place	Ref. Map. G.S.G.S. 4250	Geographical co-ordinates	Category No. of Guns	Particulars
P.1017	BOULGATE	784/256009	49 18' 12"N. 00 03' 37"W.	M.C.B. 6	(continued). undamaged. Only No. 1 is occupied. Shelters, roads and cable trenches have been damaged. Few repairs have been made. (22.5.44).
P.1017	ALBENVILLE	784/281007	49 18' 08"N. 00 01' 36"W.	Pd.Tp. ? 4	? 105 mm (4.14") Pd. gun Howa. Range 13,000x. Practical rate of fire 6-8 r.p.m. Wt. of shell 33 lbs. Centre line NE. Deep crescent layout 2,000x inland. Open circular pits 28' diam; with parapets 12' thick; 65-75x apart. Heavily camouflaged. Underground concrete shelters and magazines behind guns. CP ? central. Serviced by road and rly. Dummy at 272612. Ident: ? Div.Pd.Tp. (25.3.44).
P.1017	BURNARD	784/309000	49 17' 48"N. 00 00' 48"W.	Pd.Tp. 4	? 105 mm (4.14") Pd. gun Howa. Range 13,000x. Practical rate of fire 6-8 r.p.m. Wt. of shell 33 lbs. Centre line NW. Open emps 26' diam. Shelters w/c to rear. Sec.Armt: one lt AA to W. Dummies at 304797 and 287780. (25.3.44).
P.1017	LE MONT	784/249779	49 16' 34"N. 00 04' 05"W.	Med.Tp. (Howa.) 4	? 150 mm (5.9") Howa. Range 15,600x. Practical rate of fire about 5 r.p.m. Wt. of shell 96 lbs. Present emps are roughly constructed pits, varying from 36-48' diam, protected by irregularly shaped balist walls. Emgs sited in an arc facing North, 3,600x inland, spaced 33x apart. 2 emps unocc. Road serviced. Underground concrete magazine behind each emp. Halted camp to S of gun-pon. CP: unlocated. Communications: ? overhead cable, also wireless. No AA defences. Dummy at 236776. (24.3.44).
P.1017	GREENVILLE S.R. MER	784/256704	49 16' 50"N. 00 03' 46"W.	? Med.Tp. (7Howa.) 4	? 150 mm (5.9") Howa. Range 14,600x. Practical rate of fire about 5 r.p.m. Wt. of shell 96 lbs. Open circular emps 38-40' diam; probably with concrete beds. Emgs (70x apart) sited in an arc 4,000x inland. Centre line NW. Underground concrete personnel shelter and magazine in pairs behind each emp. Huts in rear of pon. Road serviced. MP: unlocated, probably on high ground near DIVES-sur-MER. CP probably in underground concrete shelter on gun-pon. Communications: probably buried cable, also wireless. No AA defences. Ident: ? Army Static Coast Tp. (3.5.44). Page 16.

TOP-SECRET

0148

TOP-SECRET

TOP SECRET

Chart Map No.	Place	Ref.Map. G.S.G.S. 4250	Geographical co-ordinates		Category No. of Type	Particulars
F.1017	GONNEVILLE SUR MER II	7F2/261781	49 16' 40"N.	00 03' 09"W.	Dummy	Open emps 19' diam. (28.4.44).
F.1016	RIVA BELLA	7F2/117797	49 17' 20"N.	00 15' 04"W.	M.O.S.	6 155 mm (6.1") guns. Range 25,000x. Practical rate of fire about 2 r.p.m. Wt. of shell 95 lbs. Centre line N. Arc of fire 180°. Staggered line layout on coast. Guns on wheeled mountings, the wheels being secured to the central pivot of concrete emps about 40' diam; 53-70x apart. No turret or gun shield. 4 CASEMATES, 32' x 42' w/c. These are of the "prefabricated type". Road serviced. RCP - unlocated; Shelters and magazines - underground; reinforced concrete 3'3" thick, connected with gun emps by trenches partly covered over. Administrative bldgs and accommodation for off-duty personnel in huts and houses in rear of gun posn. Sec.Armst: probably includes two or three 1t AA guns, one or two A/Tk guns and a S/L. Communications: L/T (buried cable). Ident: 1 Tp. 852 Army Coast Btn. Bomb damage: No damage to emps. Nos 2,4,5 and 6 camouflaged, probably occupied. Nos. 1 and 3 unocc. Excavations for Nos. 1 and 2 CASEMATES have been demolished, and are abandoned. Two excavations have been dug on adjoining sites. Nos. 3 and 4 CASEMATES are undamaged, and concreting is in progress. (28.5.44).
F.1016	QUISTREHAM	7F2/103779	49 16' 07"N.	00 16' 07"W.	M.O.S. (None)	6 155 mm (6.1") Hows. Range 15,000x. Practical rate of fire about 5 r.p.m. Wt. of shell 95 lbs. Centre line NE. Arc of fire ? 120°. Crescent layout 3,500x inland. Emps, circular pits diam 38"; 65x apart; probably concrete beds. 4 CASEMATES w/c. Dimensions about 37' x 46'; spaced 62-70x apart. The CASEMATES appear to be built of prefabricated concrete blocks, with walls probably bedded in reinforced concrete floors. Further reinforcement between inner and outer walls makes a total thickness of 7-10'. No.1 CASEMATE has walls complete, No. 2 is being roofed, and Nos. 3 and 4 are complete. Road serviced. RCP at 098786 with at least 2 buried shelters. Type 608 reinforced concrete

Page 17.

TOP-SECRET

0149



TOP-SECRET

TOP SECRET

Chart Map No.	Place	Ref. Map. G.S.G.S. 4250	Geographical co-ordinates		Category No. of Guns	Particulars
P.1016	OUISSEHAM	772/103779	49 16' 18"N.	00 16' 07"W.	M.C.B. (Howa.)	(continued). shelter underground to rear of bty. Communications: L/T buried cable to occ bldg to the W of the posn, and possibly from there to an OP on the coast. Dummy at 105784, occupied by dummy guns. A flimsy dummy CASEMATE has been built forward of No. 4 dummy emp, with which it is connected by a runway. Sec.Armt: 2 lt AA guns. Ident: Army Static Coast Tp. (24.5.44).
P.1016	SALLANIELES III	772/151773	49 16' 04"N.	00 12' 08"W.	Pd.Tp.	7 75 mm (2.95") Pl. guns. Range 13,000x. Practical rate of fire 6-8 r.p.m. Wt. of shell 13 lbs. Posn constructed since 14th May 1944. Guns in open emps 15' diam; 43-50x apart. Cleverly camouflaged in a hedgecock. (24.5.44).
P.1016	SALLANIELES II	772/123772	49 15' 58"N.	00 14' 27"W.	Pd.Tp.	7 75 mm (2.95") Pl. guns. Range 13,000x. Practical rate of fire 6-8 r.p.m. Posn constructed since 14th May 1944. Bty located on high ground overlooking quarry. Guns in open emps 14' diam; 32-53x apart. Bty sited to fire due W across River OUE.
P.1016	SALLANIELES I	772/155776	49 16' 15"N.	00 11' 52"W.	M.C.B. (Howa.)	7 150 mm (5.9") Howa. Range 14,600x. Practical rate of fire about 5 r.p.m. Wt. of shell 96 lbs. Centre line NE. Curved line layout 4,175x inland. Originally mounted in open circular emps, diam 36', probably with concrete beds, wheels of gun-carriage shackled to pivot of mounting. Guns now in CASEMATES 56-56x apart. No. 1 is 59' x 52' and includes compartments for personnel and ammunition. Thickness of concrete 6 1/2'. The remaining CASEMATES are 35' x 36', and consist of the gun compartment only. Arc of fire of the guns in CASEMATES NOT less than 90°, and possibly as high as 130°. The sides and roofs of the CASEMATES are earthed over. An A/Tk ditch has been dug on the North and North West side of the posn, and the bty has a perimeter minefield. Road serviced. Underground concrete shelters. Off-duty personnel are billeted in MERVILLE-FRANCOVILLE village. Possible OP's at 156792, 158789 and 161793. Communications: buried cable and probably also wireless. Sec.Armt: 7 three 20 mm AA guns. Ident: 7 Army Static Coast Tp. Bomb Damage: CASEMATES underground. Page 18 /.....

TOP-SECRET

0150

TOP-SECRET

TOP SECRET

Chart Map No.	Place	Ref. Map. G.S.G.S. 4250	Geographical co-ordinates		Category	No. of Guns	Particulars
P.1016	SALLANVELLES I	782/155776	49 16' 15"N.	00 11' 52"W.	M.C.B. (Howa.)	4	(continued). Roads and perimeter were hit. Some sympathetic detonation of perimeter mines. (21.5.44).
P.1016	LONGUES	785/797871	49 20' 39"N.	00 41' 43"W.	M.C.B.	4	155 mm (6.1"). Range 25,000x. Practical rate of fire about 2 r.p.m. Wt. of shell 95 lbs. Centre line NNE. Arc of fire 130°. Guns in CASERMATES, 52' x 65'. All four CASERMATES practically complete. Nos. 1 and 4 are occupied, Nos. 2 and 3 possibly occupied. BOP - w/c on cliff edge forward of bty. Accommodation: four large underground shelters. A minefield covers the flanks and rear of the bty. (19.5.44).
P.1016	ARROMANCHES III	785/060653	49 20' 18"N.	00 36' 33"W.	? Infantry Strongpoint	2	? 75 mm (2.95") Bd. guns. Range ? 12,000x. Rate of fire 8-10 r.p.m. Wt. of shell 13 lbs. Possibly only 75 mm Infantry guns, range 3,800x. Guns in CASERMATES, 30' x 25'. Accommodation: concrete shelters. CP: between the two CASERMATES. This is considered a beach defence strongpoint manned by infantry, and NOT a coast bty. (8.5.44).
P.1016	MONT FLEURY	785/918861	49 20' 20"N.	00 31' 37"W.	M.C.B.	4	155 mm (6.1"). Range 25,000x. Practical rate of fire about 2 r.p.m. Wt. of shell 95 lbs. Crescent layout. Four CASERMATES approx 46' x 52'. Grid bearing of centre line 353°. Arc of fire 72° either side of grid bearing for each CASERMATE, but owing to layout arc of fire for entire bty would probably be about 160°. The guns are in the open along a hedge at 916859 except for one gun which may already have been transferred to completed CASERMATE No. 1. No. 2 CASERMATE is also complete. The walls of Nos. 3 and 4 are up, but some work remains to be done on the interior. Six shelters w/c to rear of CASERMATES. ? CP in bldg 260x NNE of CASERMATES. CP w/c N of site. Camouflaged. No AA defences visible. (21.5.44).

Page 19.

TOP-SECRET

0151

TOP-SECRET

TOP SECRET

Chart Map No.	Place	Ref. Map. G.S.G.S. 4250	Geographical co-ordinates	Category	No. of Guns	Particulars
P.1016	ARROMANCHES I	785/848853	49 19' 47"N. 00 37' 24"W.	Pd.Tp.	4	? 105 mm (4.14") Ml. gun Howa. Range 13,000x. Practical rate of fire 6-8 r.p.m. Wt. of shell 33 lbs. Well camouflaged post in hedges and orchard surrounding a farm. Nos. 1 and 2 guns in camouflaged areas, 32' square. Nos. 3 and 4 in or partially in huts about 18' x 36'. No. 1 emp had camouflaging removed on 22nd May 1944 and appeared unocc. Accommodation and storage in area of farm bldgs. Probably no concrete. GP in wired area at 855855. Dummy at 844852. Communications: overhead cable to GP. No AA defences. Ident: ? Div. Pd.Tp. (22.5.44).
P.1016	ARROMANCHES II	785/846348	49 19' 34"N. 00 37' 35"W.	Pd.Tp.		Unocc post for ? 105 mm (4.14") Ml. gun Howa. Centre line NE. Open emps 20' diam in line in hedgerow; spaced 40-50x apart. No shelters seen. No camouflaging. Road serviced. Post constructed in Jan 1944, but has been unoccupied since March. (4.5.44).
P.1016	VER SUR MER	785/917844	49 19' 52"N. 00 31' 43"W.	Med.Tp. (Howa.)	7 4	? 150 mm (5.9") Howa. Range 14,600x. Practical rate of fire about 5 r.p.m. Wt. of shell 96 lbs. Centre line NE. Arc of fire 130°. Guns in line, 3,000x inland. Emps: circular pits 35' diam; 30x apart, possibly with concrete beds. 4 CASEMATES, 45' x 35' w/o; 43x apart. These are of the "refabricated type" with average thickness of walls 7-10'. Overhead camouflaging. Road serviced. OPs - unknown. CP - ? in concrete shelter in rear between Nos. 2 and 3 emps. Accommodation: underground concrete shelters. No AA defences. Dummy at 923839. Ident: Div. ? Med.Tp. (4.5.44).
P.1016	GRAYE SUR MER	785/981844	49 19' 35"N. 00 26' 18"W.	Pd.Tp.	5	? 105 mm (4.14") Ml. gun Howa. Range 13,000x. Practical rate of fire 6-8 r.p.m. Wt. of shell 33 lbs. Post constructed since 14th May 1944. Open emps 28' diam; 134-167x apart. Centre line NE. Emps pinpointed at 98208434, 98068443, 97998454. Three smaller emps 10'-12' sq near Nos. 1 and 2 guns, occupied by unidentified objects. (22.5.44).

Page 20.

TOP-SECRET

0 1 5 2

TOP-SECRET

TOP SECRET

Chart Map No.	Place	Ref.Map. G.S.G.S. 4250	Geographical co-ordinates	Category No. of Guns	Particulars
P.1016	TAILLEVILLE	785/993819	49 18' 12"N. 00 25' 15"W.	? H.A.A. ? 6	? 88 mm (3.46") H.A.A. guns. Range 16,200x horizontal, 26,250' vertical. Practical rate of fire 15-20 r.p.m. Wt. of shell 20 lbs. Typical HAA layout, about 3,800x from sea. Open emps 25' sq. of which two are now unocc. Four new emps have been constructed in rear of original six. Each contains a large rectangular or cylindrical object NOT identified. NOTE: This bty was first believed to be armed with rocket projectors, later accepted as a heavy flak bty. The exact nature of the posn is still NOT clear. (27.5.44).
					2 unidentified parallel trenches 70x long, 30' across at 992826.
P.1016	VAUX-SUR-AURE	785/792831	49 18' 29"N. 00 42' 00"W.	? Pd.Tp.	Unocc posn for ? 105 mm (4.14") Pd. gun Howa. Centre line N. Crescent layout 5,200x inland. Circular emps 30' diam; 4ix apart, probably constructed of concrete blocks. Road serviced. CP ? on high ground near COMBES. Ident: ? Div. Pd.Tp. ? Damsy at 789834. All 4 emps unocc, and No. 4 emp has been dismantled. (5.5.44).
P.1016	SOMMERVIEU	785/838820	49 17' 59"N. 00 38' 07"W.	? Pd.Tp. ? 4	? 75 mm (2.95") Pd. guns. Range 13,000x. Practical rate of fire 6-8 r.p.m. Wt. of shell 13 lbs. Open circular emps 16' diam, connected by trenches. No. 4 emp is unocc. It is NOT entirely certain that this is a genuine posn. (23.5.44)
P.1016	MOULINEAUX	785/972808	49 17' 36"N. 00 27' 02"W.	Pd.Tp. 4	105 mm (4.14") Pd. gun Howa. Range 13,000x. Practical rate of fire 6-8 r.p.m. Wt. of shell 33 lbs. Emps: circular pits diam 30'; 42-50x apart with earthen parapets. Camouflaged. CP probably on edge of wood in rear of gun posn. Shelters and magazines, huts and dugouts in woods to rear of guns. Ident: Div.Pd.Tp. Damsy posn at 968812 and 977808. (8.5.44).
P.1016	PERIERS SUR LE DAN	791/04.7772	49 15' 48"N. 00 21' 00"W.	Pd.Tp. 4	? 105 mm (4.14") Pd. gun Howa. Range 13,000x. Practical rate of fire 6-8 r.p.m. Wt. of shell 33 lbs. Centre line NNE. Guns in the open. Four old emps in the vicinity, of which one has been converted into a bunker, two others are occ by unspecified infantry weapons. (3.5.44).

Page 21.

TOP-SECRET

0 1 5 3

TOP-SECRET

TOP SECRET

Chart Map No.	Place	Ref. Map. G.S.R.S. 4250	Geographical co-ordinates	Category	No. of Guns	Particulars
P.1016	COLLEVILLE SUR ORNE	771/076782	49 16' 26"N. 00 18' 19"W.	M.Tp.	4	? 105 mm (4.14") ML gun how. Range 13,000x. Rate of fire 6-8 r.p.m. Wt. of shell 33 lbs. Centre line NE. Arc of fire 120°. Crescent layout 3,520x inland. Emps: circular pits diam 25'; 70-80x apart. All four now unoc. 4 CASERMES 35' sq w/c; 54-69x apart. Nos 1, 3 and 4 CASERMES are <del>nearly</del> complete, <del>the other two considerably</del> less advanced. Road serviced. OPs - unknown. Accommodation two underground concrete shelters, with a third w/c. Sec.Arm: ? one AA machine-gun. Ident: Div.Pd.Tr.: probably horsedrawn. Dummy at 070782, with (8.5.44). Three heavy CASERMES.
	COSSVILLE	771/045658	(Off Chart to South.	H.A.A.	4	? 80 mm (3.15") H.A.A. guns. Range 16,200x horizontal, 26,250' vertical. Practical rate of fire 15-20 r.p.m. Wt. of shell 20 lbs. Sec.Arm: three 1t AA guns. Other details NOT known. (8.5.44).
P.1015	POINTE DU HOE	684/506939	49 23' 47"N. 00 59' 22"W.	M.C.B.	6	155 mm (6.1") French guns, probably type GPF. Range 25,000x. Practical rate of fire about 2 r.p.m. Wt. of shell 35 lbs. Centre line NW. Arc of fire ? 160°. Guns on wheeled mountings, the wheels being secured to the central pivot of a concrete cap about 40' diam; emps 70-90x apart. No turret or gun shield. Bty site to form a V with apex towards coast. Four CASERMES w/c. No. 1 has walls being built. No. 2 has walls completed, roofing NOT yet begun. Nos. 3 and 4 are nearing completion. Construction is proceeding despite interruptions caused by bomb damage. Road serviced. BOP - reinforced concrete shelter on headland in front of gun posn. Flank OPs - locations unknown; presumably near PTE et RAZ DE LA PERCHE and E of GRANICAMP. Shelters and magazines - underground; reinforced concrete 3'3" to 6'6" thick, connected with gun emps by trenches partly covered over. Para bligs for off-duty personnel and administrative personnel in rear of gun posn. Sec.Arm: ? three ? 20 mm AA guns in emps on roofs of concrete shelters. Communications - 1/T (buried cable); presumably also W/T. Ident: 2 Troop, 832 Army Coast Bty. Dummy at 572945. Minefields cover the flanks and rear of

TOP-SECRET

Page 22.

0154

TOP SECRET

TOP SECRET

Chart Map No.	Place	Ref. Map. G.S.G.S. 4250	Geographical co-ordinates		Category	No. of Guns	Particulars
P.1015	POINTE DU HOE	686/586938	49 23' 47"N.	00 59' 22"W.	M.G.B.	6	(continued). the bty. Bomb damage: Slight demolition of front wall of No. 3 CASEMATE. Slight damage to open emps has been repaired. Para bldgs in rear damaged, one destroyed, one half demolished. A number of perimeter mines have been detonated. Nos. 2, 3 and 4 emps are occupied, Nos. 1 and 6 are camouflaged, possibly occupied. No. 5 has been demolished in the course of CASEMATE construction. (24.5.44)
P.1015	MAISY II	686/528915	49 22' 24"N.	01 04' 06"W.	Pd.Tp.		Temporarily unocc posn for four 7 105 mm (4.14") Pd. gun Hows. Range 13,000x. Practical rate of fire 6-8 r.p.m. Wt. of shell 33 lbs. Now being reconstructed as a CASEMATE bty. During the reconstruction, the guns are camouflaged in posn at 531914. The original open circular emps have been demolished, and 4 CASEMATES, 35' x 40', are w/c, facing NW; spaced 40x apart. Accommodation and storage: underground concrete shelters and magazines. CP - unknown. No. 1 almost complete, No. 2 well advanced, No. 3 & 4 complete. Ident: ? Div. Pd.Tp. Dummy at 527923. A minefield protects the rear of the bty. Sec. Art: two lt AA guns. Bomb damage: possible damage to AA guns. At least 175 perimeter mines exploded. (24.5.44).
P.1015	MAISY II(a)	686/531914	49 22' 14"N.	01 03' 47"W.	Pd.Tp.	4	7 105 mm (4.14") Pd. gun Hows. Range 13,000x. Practical rate of fire 6-8 r.p.m. Wt. of shell 33 lbs. Centre line NW. Staggered layout. Rough open earthen emps 20-25' diam; 32-35x apart, sited in an open field. Camouflaged. This is a temporary posn for the bty at 528915. (24.5.44).
P.1015	MAISY I	686/533918	49 22' 34"N.	01 03' 40"W.	M.G.B. (Hows.)	4	155 mm (6.1") Hows. Range 13,000x. Practical rate of fire about 5 r.p.m. Wt. of shell 95 lbs. Wide staggered trapexil layout. Guns mounted in open circular pits, 35' diam; 65-120x apart, probably with concrete beds. Bty faces VIRE estuary. Accommodation and storage: underground concrete shelters and magazines. Huts in rear. CP - underground concrete shelter centrally situated in rear of emps. CP - unknown, presumably on the coast W of GRAVICAMP. Road serviced. Communications: buried cable. Sec. Art: two 20 mm AA guns and possibly three 44 machine guns. Ident: ? ARMY Static Coast Tp. Dummy at 532923. (24.5.44). Page 23.

TOP SECRET

0155



TOP-SECRET

TOP SECRET

Chart Map No.	Place	Ref. Map. I.C.G.S. 4250	Geographical co-ordinates		Category No. of Guns	Particulars
F.1015	DEPOSSE - PORTENAY	626/517906	49 21' 52"N.	01 04' 57"W.	PL.Tp. 4	7 105 mm (4.14") Ml. gun Hows. Range 13,000x. Practical rate of fire 6-8 r.p.m. Wt. of shell 33 lbs. Bty concealed in row of trees lining a road. No minor defences or wire yet installed. (24.5.44).
F.1015	LE BASCOURTY	626/518878	49 20' 20"N.	01 04' 41"W.	7 PL.Tp.	Possible posn for four-gun PL.Tp. u/c in April 1944. Four rough unexc earthen emps. 7 15' diam; 61-77x apart. (8.5.44).
F.1015	ST. MARTIN DE VARREVILLE	625/405930	49 25' 35"N.	01 14' 50"W.	M.C.B. (Hows) 4	7 155 mm (6.1") Hows. Range 13,000x. Practical rate of fire about 5 r.p.m. Wt. of shell 95 lbs. Centre line NE. Staggered arc layout. Emps diam 31'; 50-70x apart with broad earthen parapets. 5 or 6 underground shelters connected together and with emps by comm. trench system. Camouflaged. 4 CASERMATES 50' x 55' u/c in front of old emps; spaced 60-70x apart. Arc of fire 7 140°. CP roughly central in rear of guns. One CP in trees nearby, another on ground at gun site. Dummy at 408976. Sec. Armt: 7 two lt AA guns. A trench with sloping sides 15' wide on the top surrounds the posn on the N, E, and S. Ident: 7 Army Static Coast Troop. (8.5.44).
F.1014	LA PERHELLE I	623/4/365199	49 37' 19"N.	01 18' 43"W.	Med.Tp.	Formerly occupied by four 170 mm (6.7") guns. Range 32,371x. Practical rate of fire about 1 r.p.m. Wt. of shell 150 lbs. Centre line NE. Four CASERMATES, 60' x 55'; spaced 83x apart, were u/c forward of the guns. These were heavily damaged by bombing, and it is considered probable that the site will be completely abandoned. Bomb damage: Possible damage to two guns. All four CASERMATES nearly demolished. Two guns may be in posn, but the whole site is probably unusable and may be abandoned. (25.5.44).
F.1014	HAGEAU VALETTE	623/4/336197	49 37' 02"N.	01 21' 10"W.	Med.Tp.	Unexc posn for motorized Med.Tp. Emps 33' diam; 55x apart. Centre line E. (8.5.44).
F.1014	LA PISSERIE	623/4/343192	49 36' 50"N.	01 20' 33"W.	Med.Tp.	Unexc posn for motorized Med.Tp. Emps 35' diam; 100x apart, concealed in hedgerows. (8.5.44).

TOP-SECRET

Page 24.

0156

TOP SECRET

TOP SECRET

Chart Map No.	Place	Ref. Map. G.S.G.S. 4250	Geographical co-ordinates		Category	No. of Guns	Particulars
P.1014	LA PERRILLE II	6E3/4/372198	49 37' 15"N.	01 18' 10"W.	L.C.B.	6	? 105 mm (4.14") guns. Range 19,000x. Practical rate of fire 5-8 r.p.m. Wt. of shell 33 lbs. Radial layout in groups of three. Nos. 1, 2 and 3 face ESE, and Nos. 4, 5 and 6 face E. Guns in CASERMATES, 33' x 25'; spaced 55x apart. Several shelters to rear. OP u/c between Nos. 3 and 4, partly demolished by near miss. (25.5.44).
V.1014	JOULINNE	6E3/4/358186	49 36' 38"N.	01 19' 18"W.	Med.Tp.		Unocc posn for motorized Med.Tp. Open emps 33' diam; 65-80x apart. Centre line E. (4.5.44).
P.1014	COIMBOT	6E3/4/323174	49 35' 48 "N.	01 22' 00"W.	Med.Tp.		Unocc posn for motorized Med.Tp. Centre line E. Sited in line in hedgerow. Open oval emps about 39' in length; 60-120x apart. (8.5.44).
P.1014	TRONQUET	6E3 /4/341174	49 35' 50"N.	01 20' 35"W.	Med.Tp.		Unocc posn for motorized Med.Tp. Open emps 30' diam; 60-100x apart. Cleverly concealed in a hedgerow. (8.5.44).
P.1014	QUEYTEROU	6E3/4/362174	49 35' 56"N.	01 18' 52"W.	Med.Tp.		Unocc posn for motorized Med.Tp. Open emps 25-30' diam. Camouflaged. At 362174, two emps and a possible third are u/c. (8.5.44).
P.1015	HAZEAU LE HAUT	6E3/4/105149	49 34' 05"N.	01 33' 24"W.	H.A.A.	? 6	? 60 mm (3.46") H.A.A. guns. Range 16,200x horizontal, 26,250' vertical. Practical rate of fire 15-20 r.p.m. Wt. of shell 20 lbs. Five emps occupied, sixth still u/c. Sec.Armt: two 1t AA, one 3/L. (2.5.44).
P.1014	LA POSSE	6E3/4/339138	49 33' 57"N.	01 20' 38"W.	Pd.Tp.	? 4	? 105 mm (4.14") Pd. gun Hows. Range 13,000x. Practical rate of fire 6-8 r.p.m. Wt. of shell 33 lbs. Centre line E. 4 unocc open emps diam 33'. CASERMATE construction began in June 1943. Nos. 1 and 4 are of the old type, with 1st compartment, and accommodation for personnel and ammunition and are nearly complete. Nos. 2 and 3 are of the new "prefabricated type", 40' x 27', which include only the gun compartments. CASERMATES spaced 45-50x apart. Arc of fire ? 130°. Several crew and vehicle shelters, also magazines to W of area. Camouflaged OP to the W of the bty. Road serviced. Bty shows considerable activity. Sec.Armt: two 1t AA guns. 1 tent; 1 M.V.Pd.Tp. Drives at Millal and MALILLI. (4.5.44)

TOP SECRET

Page 43.

0157

TOP SECRET

TOP SECRET

Chart Map No.	Place	Ref. Map. G. S. G. S. 4250	Geographical co-ordinates		Category No. of Guns	Particulars
P.1014	MORSALINES	683/4/354139	49 34' 02"N.	01 19' 21"W.	M.C.B. 6	155 mm (6.1") Range 25,000x. Practical rate of fire about 2 r.p.m. Wt. of shell 95 lbs. Centre line E. Arc of fire 360°. Crescent layout 50-75x apart. Guns shackled to pivot-mountings of open circular concrete emps 40' diam. Each emp has a rear opening, with magazines at either side. Accommodation: underground concrete shelters. Camouflaged CP 90x in front, connected by cable trench. Aux. CP and CP believed located in tower W of No. 6 gun. Road serviced. Sec. Arm: two AA/A-Tk guns flanking forward CP. Ident: Army Coast Tp. Bomb damage: Nos. 3 and 6 emps damaged, No. 3 unoccupied. Slight damage to shelters, roads, and communication trenches. Few repairs made. (27.5.44).
					Emps Nos. 1 - 4 unocc, Nos 5 & 6 damaged but possibly occ.	
P.1013	LES AULNEYS	683/4/179111	49 31' 58"N.	01 33' 43"W.	H.A.A. 4	? 88 mm (3.46") H.A.A. guns. Range 16,200x horizontal, 26,250' vertical. Practical rate of fire 15-20 r.p.m. Wt. of shell 20 lbs. Three 1t AA guns and a S/L about 200x to N. Other details unknown. (2.5.44).
P.1013	ST. JOSEPH	683/4/203113	49 32' 15"N.	01 31' 42"W.	H.A.A. 6	? 88 mm (3.46") H.A.A. guns. Range 16,200x horizontal, 26,250' vertical. Practical rate of fire 15-20 r.p.m. Wt. of shell 20 lbs. Other details unknown. (2.5.44).
P.1014	LESYRE II	683/4/355106	49 32' 10"N.	01 19' 11"W.	Infantry Strongpoint	Reported earlier as a possible four-gun bty w/o, this post is now seen to be a strongpoint with 5 dugout shelters, firing trenches and perimeter wire. (22.5.44).
P.1014	LESYRE	683/4/342102	49 31' 58"N.	01 20' 16"W.	Med. Tp. (Howa.)	Unocc post for four ? 150 mm (5.9") Hows. Range 14,600x. Practical rate of fire about 5 r.p.m. Wt. of shell 96 lbs. Centre line E. Posts in line 36-50x apart, 2.2 miles inland. Concrete emps 40' diam with 25' traversing ring. Shelters and magazines directly to rear of bty. Road serviced. ? CP and BCP 350x to NE, serving as outer defense for the bty. In this area are four concrete shelters, two with possible AA emps on roofs. Ident: ? Div. Med. Tp. Bury at 340000. (22.5.44).

Page 26.

TOP SECRET

0158

TOP-SECRET

TOP SECRET

Chart Map No.	Place	Ref. Map. G.S.C.S. 4250	Geographical co-ordinates	Category No. of Guns	Particulars
P.1014	MONT COQUEREL	683/4/361000	49 30' 52"N. 01 18' 35"W.	L.C.B. 4	? 75 mm (2.95") guns. Range 17,800x. Practical rate of fire 15-20 r.p.m. Wt. of shell 14.5 lbs. Centre line NE. Arc of fire ? 140°. Guns in CASERMATES 18' x 30'; spaced 50x apart, sited radially in pairs. Accommodation: concrete shelters w/c. No AA defences. (8.5.44).
P.1013	ROUVILLE	683/4/189073	Off Chart to South.	H.A.A. 4	? 88 mm (3.46") H.A.A. guns. Range 16,200x horizontal, 26,250' vertical. Practical rate of fire 15-20 r.p.m. Wt. of shell 20 lbs. Other details unknown. (5.5.44).
P.1014	LOSSIERE	683/4/297054	49 29' 16"N. 01 23' 46"W.	Fd.Tp. 4	? 105 mm (4.14") Md. gun Howa. Range 13,000x. Practical rate of fire 6-8 r.p.m. Wt. of shell 33 lbs. Guns in roughly constructed open emps 24' internal diam, 34' across parapets, camouflaged and concealed in hedges. Spacing 140-203x apart. Centre line SW. A single local defence emp 290x in rear. (19.5.44).
P.1014	OZEVILLE	683/4/343057	49 29' 33"N. 01 19' 57"W.	Med.Tp. (Howa.)	Unocce post for two ? 150 mm (5.9") Howa. Range 14,600x. Practical rate of fire about 5 r.p.m. Wt. of shell 96 lbs. Centre line ENE. Emgs 40' diam; 50x apart. Accommodation: underground shelters. (18.5.44).
P.1014	CHATEAU DE COURCY (PORTENAY)	683/4/361056	49 29' 33"N. 01 18' 28"W.	L.C.B. 4	? 105 mm (4.14") Md. gun Howa. Range 13,000x. Practical rate of fire 6-8 r.p.m. Wt. of shell 33 lbs. Crescent layout. Emgs 39' x 39' w/c; 65x apart. No. 2 is nearing completion. Guns concealed in hedges at 361053; spaced 42-63x apart. Accommodation: underground concrete shelters. Sec.Arm: ? two 1t AA guns. (8.5.44).
P.1014	CRISHEDQ	683/4/368044 369040	49 28' 56"N. 01 17' 52"W.	H.C.B + H.A.A. 6 6	155 mm (6.1"). Range 25,000x. Practical rate of fire about 2 r.p.m. Wt. of shell 95 lbs. Centre line ENE. Shallow crescent layout. Emgs 45' diam, approx 50x apart. 6 sunken concrete shelters or magazines 50' sq. located close behind the guns. 2 larger shelters 100' x 20' off each flank. Guns and shelters connected by cable trench. CP central. Serviced by road and t rly. Four CASERMATES 54' x 76' w/c; 86-100x apart. These are of the /.....

Page 27.

TOP-SECRET

0159

TOP SECRET

TOP SECRET

Chart Map No.	Place	Ref. Map. G.S.G.S. 4250	Geographical co-ordinates		Category No. of Guns	Particulars
P.1014	CRISEBOQ	6E3/4/369044 369040	49 28' 56"N.	01 17' 52"W.	M.C.B. + H.A.A. 6 6	"prefabricated type". Estimated thickness of walls 7-10'. Arc of fire of guns in CASEMATES ? 120°. Arc of fire for entire bty ? 100°. Nos. 1 and 2 CASEMATES are complete and may be occupied. No. 3 has walls up, but lacks roof. No. 4 has NOT advanced much beyond the excavation stage. All six original open emps are unocc. Darry at 365041. Sec.Armt: 3-5 lt AA guns. A six gun heavy AA bty installed at 369040, probably 88 mm (3.46") guns. Range 15,200x horizontal, 26,250' vertical. Rate of fire 15-20 r.p.m. Wt. of shell 20 lbs. Bomb damage: Nos. 3 and 4 CASEMATES damaged. Work is probably continuing on No. 3, while No. 4 may possibly be abandoned. Two shelters and the CP have been hit. The main road through the post and the lt rly serving the construction have been blocked. Very little clearing of bomb damage has been done on the site. (19.5.44).
P.1014	AZEVILLE	6E3/4/369023	49 27' 48"N.	01 18' 30"W.	Pd.Tp. 4	? 105 mm (4.14") Pd. gun Hows. Range 13,000x. Practical rate of fire 6-8 r.p.m. Wt. of shell 33 lbs. Centre line NE. Arc of fire ? 120°. Guns in concrete CASEMATES, 50' x 52' in line 55x apart. 3 small huts and 4 large shelters in rear. Camouflage and further construction in progress. Ident Div.Pd.Tp. Sec.Armt: three lt AA guns on roofs of Nos. 1, 2 and 4 CASEMATES. (3.5.44).
P.1014	AZEVILLE II	6E3/4/369017	49 27' 26"N.	01 18' 10"W.	Pd.Tp. ? 2	? 105 mm (4.14") Pd. gun Hows. Range 13,000x. Practical rate of fire 6-8 r.p.m. Wt. of shell 33 lbs. 4 open emps 25' diam, two unocc (in hedgerow). (3.5.44).
P.1014	LES FARRES	6E1/3/0291	49 42' 06"N.	01 22' 49"W.	L.C.B. ? 2	? 105 mm (4.14") Pd. gun Hows. Range 13,000x. Practical rate of fire 6-8 r.p.m. Wt. of shell 33 lbs. One gun in a CASEMATE 36' x 22'. Centre line NE. Arc of fire ? 120°. A second CASEMATE is w/c 96x to the S, facing NE. Hedges and brush have been cleared between the CASEMATES and the coast. (22.5.44).

Page 26.

TOP SECRET

0160

TOP SECRET

Chart No.	Place	Ref. Map. S.S.G.S. 4250	Geographical co-ordinates		Category No. of Guns	Particulars
P.1014	PORTS DE REVILLE	621/356291	49 42' 10"N.	01 20' 00"W.	M.C.B. 7 4	7 150 mm (5.9") Coast guns. Range 24,000x. Practical rate of fire 2-4 r.p.m. Wt. of shell 113 lbs. Arc of fire 7 180°. Triangle layout on point of land extending into sea. Original three guns in Naval barrels, 12' x 8' in 23' concrete caps, and are now in completed CASEMATES 20' x 27'; 54-83x apart. No. 1 faces NE, Nos. 2 and 3 face N. A fourth CASEMATE of entirely different type, measuring 47' x 43', has been built 32x SE of No. 1. This CASEMATE faces NE, and may house a fourth medium coast gun. It is possible, however, that it contains a medium flare gun, and is NOT part of the main arm of the bty. Accommodation: concrete shelters, also huts. BOP in concrete shelter centrally in front of guns. Sec. Arm: two 1t AA guns and a possible S/L. Ident: Batterie HAARENNESS of 260 Naval Coast Btn. (24.5.44).
P.1014	VAL BOURNOIN	621/256278	49 41' 15"N.	01 28' 05"W.	Pd.Tp. 4	7 105 mm (4.14") Pd. gun Hows. Range 13,000x. Practical rate of fire 6-8 r.p.m. Wt. of shell 35 lbs. Centre line W. Crescent layout. Guns in open circular earthen caps 30' diam; 50-60x apart. Accommodation: concrete shelters. Dummy at 294203. (18.5.44).
P.1014	LES SEINS	621/306273	49 41' 05"N.	01 24' 05"W.	Med.Tp. (Hows.) 4	7 150 mm (5.9") Hows. Range 14,600x. Practical rate of fire about 5 r.p.m. Wt. of shell 96 lbs. Centre line NNW. Staggered crescent layout. Open earthen caps diam 40'; 66-72x apart. 2 concrete magazines, each serving two guns. Three large huts in rear. CP central in rear of posn. No camouflage. Ident: ? Div.Pd.Tp. Dummy at 299271. (22.5.44).
P.1014	GATTEVILLE	621/392276	49 41' 30"N.	01 16' 42"W.	M.C.B. 6	155 mm (6.1"). Range 25,000x. Practical rate of fire about 2 r.p.m. Wt. of shell 95 lbs. Centre line NNW. Open caps 45' diam; 75-95x apart, in staggered line layout. Each cap except No. 6 has two shelters close in front. Four CASEMATES, 32' x 48' completed, 75-96x apart. These are of the "prefabricated type", with thickness of walls estimated at 7-10". CASEMATES sited radially in pairs. Arc of fire of guns in CASEMATES 7 180°. The six original open caps are occupied. Accommodation: concrete shelters, also huts. ? OP's at

Page 29.

TOP SECRET

0161



TOP-SECRET

TOP SECRET

Chart Lat. No.	Place	Ref. Map. S.S.L.S. 4250	Geographical co-ordinates		Category	No. of guns	Particulars
P.101A	GATTEVILLE	681/392275	49 41' 30"N.	01 16' 42"W.	H.C.B.	6	(continued). 389278 (no concrete) and 396275. Sec.Arm: two 20 mm AA guns. Ident: Army Coast Tp. Strength 120 men. Dismy at 395276. (22.5.44).
P.101A	LES LAURES	681/365266	49 40' 28"N.	01 28' 48"W.	Dismy		Former French bty abandoned for at least two years. (22.5.44).
P.101A	CASBIVILLE	681/258267	49 46' 46"N.	01 27' 43"W.	? H.C.B.	4	? 105 mm (4.1L ") Hl. gun Howa. Range 13,000x. Practical rate of fire 6-8 r.p.m. Wt. of shell 33 lbs. Centre line N. Arc of fire ? 120°. Guns in CASBATES, 39' x 32'; 65-70x apart. Probable shelter 1/2 between Nos. 2 and 3. Accommo- dation in bldgs E of site. (22.5.44).
P.101A	PRECAVILLE	681/258267	49 40' 40"N.	01 27' 20"W.	H.C.B. + H.A.A.	4 6	? 200 mm (11") guns. Range reported as 40,000x. Wt. of shell 660 lbs. Centre line NE. Open square layout. Guns in armoured turrets 14' x 23' in concrete cups 40' diam; 160-200x apart. Served by road and rail. Structures resembling CASBATES are now being built at all four gun poms. It is NOT clear at the present whether these are intended merely as accommodation for personnel and am; or whether the guns too, will be roofed over. Arc of fire ? 130°; with a possible max. of ? 180°. BCP at 26352754, with two 1t AA guns, connected by underground cable with Radar stns at MAHERBUS and CAP LEVI. Accommodation: Numerous bldgs on site. Sec.Arm: six 1t AA guns, two on the E flank of the pom, and one near each gun. 2 possible "L's. In addition, a six-gun heavy flak bty has been installed on the SE flank of the bty at 262265. These are probably 88 mm (3.15") guns, range 15,200x horizontal, 26,250' vertical, rate of fire 15-20 r.p.m. wt. of shell 20 lbs. The whole area is elaborately wired, with very strong infantry defences. Ident: Batterie MAHERBUS of 260 Naval Coast Btn. Strength about 100 men, of whom 50 are at the BCP. (22.5.44).
P.101A	MAHERBUS	681/258267	49 39' 10"N.	01 29' 23"W.	H.A.A.		Unoc pom for six 88 mm (3.15") guns. ? 4 1t AA guns in area. One 1/2 to 1 of pom, another to E. (22.5.44).

Page 30.

TOP-SECRET

0162

TOP SECRET

TOP SECRET

Chart No.	Place	Ref. Map S.S. No. 450	Geographical co-ordinates		Category No. of Guns	Particulars
P.1011	LAZAROUF	681/337434	49 59' 03"N.	01 21' 07"W.	? Med.Tp. (Howa.)	? Prepared pens for four-gun Med.Tp. Four unoco circular emps 45' diam, in irregular arc facing NE. (8.5.44).
P.1011	BAUFLON (BAY FARVILLE)	681/396229	49 38' 55"N.	01 16' 17"W.	Med.Tp.	Four ? 170 mm (6.7") guns, formerly concealed in hedgerows. (Range 32,371x. Practical rate of fire about 1 r.p.m. Wt. of shell 150 lbs.) Centre line E. The guns were removed on 9th May 1944, and have NOT since been located. (22.5.44).
P.1011	ALIGNMENT	681/376204	49 37' 34"N.	01 17' 38"W.	M.C.B. (?Howa.)	Unoco pens for four ? 155 mm (6.1") Howa. Range 13,000x. Practical rate of fire about 5 r.p.m. Wt. of shell 95 lbs. Centre line E. Crescent layout. 5 earthen emps diam 35'; 50-60x apart. The pens have been unoco since Nov. 1943. (8.5.44).
P.1013	FORT CENTRAL	681/146270	49 40' 30"N.	01 37' 05"W.	M.C.B.	4 mountings visible. Probably part of the 158 mm French guns with which this bty was formerly armed in 1939. Such guns have range 12,300x; rate of fire 2 r.p.m.; wt. of shell 87 lbs. Centre line N. Concrete pits 27' diam; spaced 67x apart. 3 in crescent layout facing N, one facing S. BCP - CP in centre of fort. 4 or 5 bldgs. Serviced by water and road. Ident: Batterie MOLE (260 Naval Coast Btr.) Sec.Armt: three HAA guns between emps, one lt AA to rear of fort. NOTE: There have been frequent reports of coast guns mounted here, but only the mountings have been seen on aerial photographs. (8.5.44).
P.1013	FORT DE L'ETRE PELLE	681/171264	49 40' 14"N.	01 35' 00"W.		French fort now believed dismantled. In addition to emps for 4 Med. guns, there are pens for a 4-gun Heavy AA Tp. All are believed unoco at present. Present armt now consists of three lt AA guns and a S/L. A possible gun CALIBRE 25' x 30' at SW corner of fort (centre line S) may contain a lt gun. (8.5.44).

Page 31.

TOP SECRET

0163

TOP SECRET

TOP SECRET

Chart Map No.	Place	Ref. Map G.S.G.S. 4250	Geographical co-ordinates		Category No. of Guns	Particulars
P.1013	POST DES TORPILLES	6E1/123250	49 39' 21"N.	01 38' 54"W.	H.A.A. 6	? 88 mm (3.46") HAA guns. Range 16,200x horizontal, 26,250' vertical. Practical rate of fire 15-20 r.p.m. Wt. of shell 20 lbs. Circular layout. Bty located N of the rly turntables. Sq emps 26' across heavily revetted, on roofs of shelters (type L/401); 47-89x apart. Sec.Arm: ? Five AA machine guns. One, possibly two S/L's to E. Auxiliary CP central. Main CP and predictor apparatus to S, connected with post by cable trench. (8.5.44).
P.1013	CHERBOURG RAMPARTS	6E1/127253	49 39' 31"N.	01 38' 31"W.	L.C.B. ? 4	? 105 mm (4.14") Pd. gun Hows. Range 13,000x. Practical rate of fire 6-8 r.p.m. Wt. of shell 33 lbs. Centre line NNE. Bty covers the Northern Approaches to CHERBOURG. Arc of fire ? 120°. 4 CASEMATES 37' x 63', probably occupied. Several shelters in area. No camouflage. Served by road and rail. ? CP between Nos. 2 and 3. ? BOP close in on W flank. Sec.Arm: ? one 1t AA gun, and two possible 1t artillery pieces in wired area E of the post. (8.5.44).
P.1013	CHERBOURG RAILWAY BATTERY	6E1/125246	49 39' 10"N.	01 38' 44"W.	H.Rly. B.	Formerly occupied by 4 x ? 280 mm, railway guns on turntables 65' diam; 55-60x apart. The turntables have been unocc. since December 1943. Work has been done on dismantling the turntables, of which Nos. 1 and 3 are now unusable, and it is probably intended to abandon the site. The guns were reported at TORIGNI-ST.AMAND in January 1944, but are believed to have left there in February 1944. Their present location is NOT known. (8.5.44).
P.1013	CHERBOURG - QUAY	6E1/157242	49 39' 00"N.	01 36' 04"W.	H.A.A. ? 8	? 88 mm (3.46") HAA guns. Range 16,200x horizontal, 26,250' vertical. Practical rate of fire 15-20 r.p.m. Wt. of shell 20 lbs. Emgs square, revetted, 25' across, distance apart 42-110x, on roofs of concrete shelters (type L/401). Accommodation: barbed concrete shelters near guns. Numerous huts and dugouts for ems. Auxiliary CP central. Main CP in concrete shelter to S, with a Wernberg, range finder and predictor, and a S/L. Sec.Arm: three 1t AA guns, two of them on roofs of concrete shelters. All guns could be used against shipping. Two posts unocc since Jan '44 - this is now probably a normal 6-gun HAA bty. (8.5.44).

TOP SECRET

0 1 6 4

Page 32.

TOP SECRET

TOP SECRET

Chart Map No.	Place	Ref. Map. G. S. G. S. 4250	Geographical co-ordinates		Category	No. of Guns	Particulars
F.1013	PORT DES FLAMANDS	6E1/171245	49 39' 11"N.	01 35' 45"W.	L.C.B.	2	? 75 mm (2.95") Coast guns. Range ? 17,800x. Practical rate of fire 15-20 r.p.m. Wt. of shell 14.3 lbs. Centre line N. Arc of fire ? 120°. Guns in CASEMATES about 29' x 32'; 125x apart, in line along coast. Both are earth covered except for entrance and gun port. Shelters and magazines in rear. Served by road. CP central. Possible S/L to NE. Sec.Armt: two 1t AA guns. (8.5.44).
F.1013	TOURLAVILLE (CAPELAINE)	6E1/189238	49 38' 53"N.	01 35' 26"W.	M.C.B.	4	? 164 mm (6.46") French guns. Range 20,000x. Practical rate of fire about 3 r.p.m. Wt. of shell 110 lbs. Centre line N. Guns originally mounted in turrets in circular concrete emgs, diam 30', 125-134x apart. No. 1 gun now in CASEMATE 60' sq. No. 2 gun in original emg with CASEMATE w/c alongside; No. 3 gun in CASEMATE; No. 4 gun in smaller CASEMATE 40' x 25'. Garrison housed in bldgs behind guns. Served by road. ? One S/L. Ident: ? Tp of 260 Naval Coast Btr. Sec.Armt: at least three 1t AA guns. BQ's at 187237 and 188238. (8.5.44).
F.1013	HAMEAU BURNEL	6E1/194235	49 38' 48"N.	01 33' 00"W.	H.A.A.		Unococ pon for six-gun ? 88 mm (3.46") H.A.A. bty. (8.5.44).
F.1013	MONTAGNE DU ROULE	6E1/147221	49 37' 53"N.	01 36' 50"W.		? 5	? 150 mm (5.9") guns. Range 21,000x. Practical rate of fire 2-4 r.p.m. Wt. of shell 113 lbs. Guns mounted in tunnels cut into cliff below PORT DU ROULE, and firing out of CASEMATE-like structures 37' wide, 30-35x apart, projecting about 20' from the rock at approx. the 90 meter contour. These are sited radially from NE to NW. Only four of these structures can be definitely identified on photographs. The exact armt of this pon is unclear. Ground sources have persistently reported heavy naval guns on rails being installed here, and recent reports state that five such guns fired practice shots in March 1944. There are also reports of a number of heavy flak emgs dug into the cliff at different heights. The PORT DU ROULE is reported as the most heavily defended pon in the CHEBOURG area. (8.5.44)

Page 33.

TOP SECRET

0165

TOP-SECRET

TOP SECRET

Chart Map No.	Place	Ref.Map. S.S.G.S. 4250	Geographical co-ordinates	Category No. of Guns	Particulars
P.1013	MOOSVILLE	621/205218	49 37' 55"N. 01 32' 03"W.	L.C.B. 4	7 105 mm (4.14") Pd. gun Hows. Range 13,000x. Practical rate of fire 6-8 r.p.m. Wt. of shell 33 lbs. Centre line NE. Arc of fire ? 120°. Crescent layout. Guns in CASSEATES 40' x 40'; 70x apart. Sec.Arm: three 1t AA guns, installed on the roofs of Nos. 2,3 and 4 CASSEATES. Arm bunkers in hedge 80x to rear. Dummy at 205210. (22.5.44)
P.1013	PIERRE BOUQUET	621/192219	49 37' 53"N. 01 33' 05"W.	? Pd.Tp.	Unrec 4-gun posn. Hexagonal emps 25' diam; 50-57x apart. Circular layout on ramparts of old fort. Served by road. Some activity on site. (8.5.44).
P.1013	ORCHERIE	621/207211	49 37' 24"N. 01 31' 54"W.	Pd.Tp. 4	7 150 mm (5.9") Hows. Range 14,600x. Practical rate of fire about 5 r.p.m. Wt. of shell 96 lbs. Centre line NW. Open circular emps diam 10'; 60-70x apart. Served by road. Camouflaged. Dummy to S. Sec.Arm: three 1t AA guns. (8.5.44).
P.1013	LA VARE A CANAROS	623/4/154197	49 36' 35"N. 01 36' 11"W.	H.A.A. 6	7 105 mm (4.14") HAA guns. Range 19,100x horizontal, 31,000' vertical. Practical rate of fire 10-15 r.p.m. Wt. of shell 33 lbs. Oval layout. Open emps 25' sq; 35-160x apart. No camouflage. ? CP-CP to NE. One S/L to S. Sec.Arm: three 1t AA guns. (8.5.44).

TOP-SECRET

Page 54.

0166

TOP SECRET  
BIGOT

REF: 100/1001  
SECRETARY OF DEFENSE  
ARMED FORCES  
9-2 (SPECIALTY BRANCH)

TOP SECRET  
REF: 101  
2 June 1944

REPORT NUMBER: 36

In this Report:

- Appendix 'A' - Artillery
- Appendix 'C' - Mine Defenses
- Appendix 'D' - Obstacles
- Appendix 'E' - Acquisition Targets

Petrol Depot at DREYER.

1. REFERENCE Reference No: G.S.C.S. 1050/701.  
 (a) A daily train of petrol and straw protected with  
 ... was passed daily on the line ALBANY-DOYER.

Comment:

This report is from a casual source but likely, there  
being an important bulk depot and clocked distillery  
in the area at DREYER.

Date of Information: Beginning  
May 1944.

(b) What may be one stack of straw is seen at 775025.

Air Cover: Article: 100/111  
of 2 May 44.

Photo No: 5004.

Date of Information: 28 May 1944

Comment:

Four stacks of petrol straw had previously been  
confirmed at this top reference. It formed one of  
the two fuel depots at DREYER. It has probably  
been moved.  
100/111/100/1.2 para 2 and 100/111/100/1.2 para 4, third item  
should be amended accordingly.

Underwater Obstacles: SECRETARY'S OFFICE.

2. The following from a new source, is for reliable:  
 The SECRETARY'S OFFICE is present making at SECRETARY'S OFFICE concrete  
 blocks of the following type.

CONFIDENTIAL

9510

TOP SECRET  
BIGOT

#1675

0167

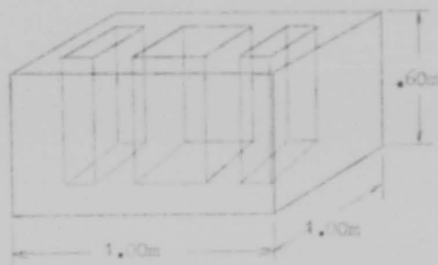

TOP SECRET  
BIGOT

The block has three cavities, the centre one being 60 cm x 60 cm x 50 cm deep, the others 30 cm x 30 cm x 50 cm deep. In the centre cavity there is a "mechanism" from which emerges a wire lead (all conductors). More precise information is NOT AVAILABLE, but in source's opinion everything points to electrically controlled explosive devices. The blocks are intended, it appears, to be laid on the beaches".

Comment:

These blocks are clearly to be related to blocks of similar dimensions already confirmed on beaches in the MEDITERRANEE area and elsewhere on the GULF OF COAST. Source is possibly inaccurate as regards dimensions and the number of cavities, and the mechanism may be less elaborate than he thinks. The report is significant, however, in that it definitely associates the blocks with mines, thus strengthening the case for identifying the blocks with the "mine-boxes" reported from DENMARK (see MEDITERRANEE AREA NO. 24, paragraph 2).

Send-loops near MEDITERRANEE.

3.

Reference Map: G.S.N.S. 4347, Sheet 40/16 NW.

Loops similar to those reported in MEDITERRANEE AREA NO. 53, paragraphs 3 and 4 are seen in various stages of construction at :

10737800	09377828
10637756	09377877
09537708	09377890
09637703	09377904
09537717	09377938
09297648	09297636
09377815	

Anti-tank guns in the THACN area.

4. It now appears that two of the number of anti-tank guns in open positions, already reported in the THACN area (G.S.N.S. 4347, 37-16 NE, 84747 and 84775) were in fact only in temporary positions while more permanent replacements were under construction. In each case the new positions are NOT more than 100 yards away; there is one entirely new position,

/at present.....

TOP SECRET  
BIGOT

0 1 6 8

TOP SECRET  
BIGOT

at present unoccupied, at 292763.

Air Cover: Sertic 400/167  
of 27 May 44.Photo Nos: 3418/9Bridging equipment near QUERVEN

5.

Ref. Maps: GCS 1/50,000 sheet 62/5

A report dated April 44 from a source of unknown reliability states that horse-drawn vehicles carrying ponton bridging equipment are located under the trees on the N. bank of the QUERVEN canal (BARKIN FLOT) between Hart dyke and the reservoir just north of QUERVEN. The equipment consists of 12 vehicles each carrying a boat and 20 vehicles carrying bridge trunks, beams, etc.

Photos 4061-64 of Sertic 400/29 of 23 Apr 44, of good quality, show what could be a line of vehicles parked under the trees at the pin-point location 401850. Between the 23 Apr 44 and the 7 May 44 (Sertic 1066/209) the foliage on the trees has thickened making it impossible to confirm whether the vehicles are still there.

Air Cover: Sertic 400/19  
of 23 Apr 44  
Sertic 1066/209  
of 7 May 44.Photo Nos: 4061-64Unexplained construction of "canoes" in the forest QUERVEN

6.

Ref. Maps: GCS 4347 Sheet 31/2002  
358189

Photographs of 31 May show work in progress at a small North of QUERVEN, which had been derelict for some months. The objects now being fabricated can NOT be identified. They resemble a rough-made canoe. Dimensions are as shown in the following sketch. There are 23 "canoes" on the site at present.

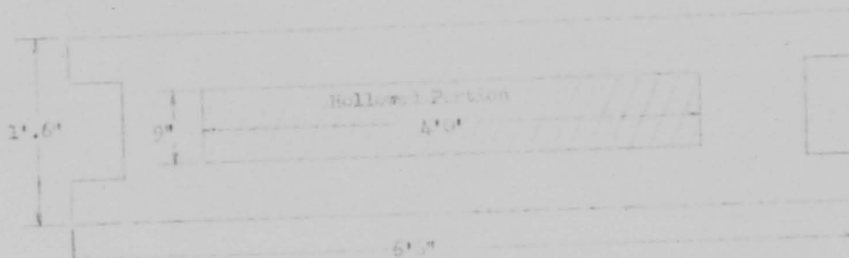

The final stages of the work appear to involve covering over, possibly with tarpaulin, the hollow part in the middle, and the finished object appears to have tapered ends.

Sertic: 16/35, 3048 and 4056.Comment:

There is no other information on these objects. It is NOT known where they are taken on completion. Their shape certainly suggests that they are intended to float, and it is suggested that they may turn out to be a new type of raft obstacle to be used in shallow water off landing-beaches.

/Possible projector.....

TOP SECRET  
BIGOT0 0 3 8  
0 1 6 9

TOP SECRET  
BIGOT

- 4 -

Possible projector batteries in the NEMTSU area

7. Appendix "A" to this report contains references to two further batteries, one in GUY 208, and the other is the COYENNY, with the suggestion that they may be projector (or laser) batteries. It should be observed that the photographic evidence is still inconclusive, although both positions present some features associated with projectors.

SP 114 at NEMTSU (cont)

Ref. Top: 13014347 Sheet 31/131  
20029178

Examination of photographs of SP 114 reveals three occupied rectangular placements 32 feet by 20 feet overall, heavily embanked with earth, also of equal diameter equipment, 10 feet in diameter. Other activity is visible in the same field as the placements and also in the adjacent field. Comparison with photographs from other theatres indicates that this is a major SP 114 unit.

Article: 11045, 2066-7.

*DMS Hayes*  
*Capt*

Major-General,  
C. of S.  
B-2.

TOP SECRET  
BIGOT

0 0 0 0  
0 1 7 0

TOP SECRET  
BIGOT

TOP SECRET

APPENDIX 'A' TO REPORT AREA NO. 36  
Dated 2 June 1944Artillery in the REPORT AREA

1. L'ORLERIE Ref. Map: GCS 4250/724 & 823/  
624417  
Four emplacements 25 feet in diameter, 36-47 yards apart, occupied by unidentified objects. Nos. 2, 3, and 4 appear to have split trails. Little track activity visible.  
Air Cover: Sortie 1063/409 of 25 May 1944 Photo Nos. 4045, 4045  
Comment:  
It is NOT clear that this is a genuine position.
2. LE MOSE Ref. Map: GCS 4250/517/046103  
Four-gun field battery in open earthen pits 16 feet in diameter.  
Air Cover: Sortie 1064/434 of 19 May 1944 Photo Nos. 4102-3
3. CARTERET Ref. Map: GCS 4250/506/998945  
The following is the state of construction at this four-gun medium concrete battery:  
No. 1 concrete still building; No. 2 further advanced; No. 3 appears to have roofing in progress; No. 4 appears complete.  
Air Cover: Sortie 1073/4042 of 31 May 1944 Photo Nos. 2055-6
4. CREPON Ref. Map: GCS 4250/735/90280239  
Six occupied earthen emplacements 20 feet in diameter are visible here. They are sited in an irregular line. One or two small excavations are apparent nearby, and considerable track activity is visible.  
Air Cover: Sortie 16/345 of 30 May 1944 Photo Nos. 4216-7  
Comment:  
These are probably light guns, or possibly projectors.
5. LES LERS BELISE Ref. Map: GCS 4250/625/35349590  
Four open circular emplacements are seen in line in a field South of the town. All are unoccupied. Nos. 1, 2, and 3 emplacements are 20 feet in diameter, No. 4 is 27 feet in diameter. Distance between emplacements varies from 42 to 55 yards.

-/Toopen...

9 SPIC

TOP SECRET  
BIGOT

0171

TOP SECRET  
BIGOT

-2-

Weapon pits are seen at 35172625, 35359580, 35309578, and 35159630.  
Traces have been pulled along the Northern side of the field in which the  
applacements are located.

Air Comm: Bertic US 31/445  
of 24 May 1944  
Bertic US 30/4042  
of 31 May 1944

Photo Nos: 1013-15  
Photo Nos: 1144-45

Comment:

Probably a prepared position for a P-14 troop.

G-2 (Intelligence) Division,  
SECRET  
7 June 1944

TOP SECRET  
BIGOT

0 1 7 2

TOP SECRET  
BIGOTTOP SECRET.APPENDIX 'C' TO REPORT SERIES NO. 36.  
Dated 2 June 1944.LIGHT DEFENCES.

1. SOTTENVILLE Reference Map: G.S.G.S. 4347/28/20 NE  
& N.  
A shelter with blast walls and two huts at 033119.  
Air Cover: Sortie 1060/606 of Photo Nos: 3032  
30 May 44. Date of Information: 30 May 44.
2. LA RUE Reference Map: G.S.G.S. 4347/28/22  
Composite  
Ten pits approximately 8 feet in diameter at 973245, three at 974246 and three at 975245.  
Air Cover: Sortie 16/335 of Photo Nos: 4013  
29 May 44. Date of Information: 29 May 44.
3. LES PANORAMAS Reference Map: G.S.G.S. 4347/40/16 NE  
Detected heavy anti-tank gun position at 191792. Excellent large scale cover reveals no trace of this gun.  
Air Cover: Sortie 400/183 of Photo Nos: 4018, 4037  
30 May 44. Date of Information: 30 May 44.
4. BURG de LESTRE Reference Map: G.S.G.S. 4347/31/20 SE  
Unoccupied emplacement and shallow trench at 358089.  
Air Cover: Sortie 16/262 of Photo Nos: 4002  
24 May 44. Date of Information: 24 May 44.
5. BTIGNVILLE Reference Map: G.S.G.S. 4347/31/18 NE  
Three probable dugouts under construction at 277945. Weapon pits at 26269375, 26489390 and 26509372. Row of six pits or dugouts under construction along hedge at 26509374.  
Air Cover: Sortie 1060/455 of Photo Nos: 4109/10  
22 May 44. Date of Information: 22 May 44.
6. FOUENVILLE Reference Map: G.S.G.S. 4347/34/20 SE  
Turret 12 feet in diameter on sea-wall at 41100274 and two small turrets on the sea-wall at 41450212 and 41500191; a probable tank turret at 418016. Pillbox at 411011 and 41470000.  
Air Cover: Sortie 16/325 of Photo Nos: 3017/9 4012/3  
29 May 44. Date of Information: 29 May 44.

/7. VERBOD.....

CONFIDENTIAL  
9SPICTOP SECRET  
BIGOT0 0 0  
0 1 7 3  
1 0 2 4



TOP SECRET  
BIGOT

7. VERDON Reference Map: G.S.G.S. 4347/31/16 SE  
 Employment with probable anti-tank gun at 960667.  
 Air Cover: Sortie 400/162 of Photo Nos: 3301/2  
 30 May 44. Date of Information: 30 May 44.
8. ESAIL PITHI Reference Map: G.S.G.S. 4347/31/16 SE  
 Probable unoccupied anti-tank gun emplacement at 899696.  
 Air Cover: Sortie 160/167 of Photo Nos: 4141/2  
 27 May 44. Date of Information: 27 May 44.
9. ST. ISERE Reference Map: G.S.G.S. 4347/31/16 SE  
 Probable unoccupied anti-tank gun emplacement at 852680.  
 Air Cover: Sortie 400/167 of Photo Nos: 4002/3  
 27 May 44. Date of Information: 27 May 44.
10. ST. SULICE Reference Map: G.S.G.S. 4347/31/16 SE  
 A small trench system with fire wells has been built at  
 017823. A line of wire is visible on the eastern and southern sides.  
 Air Cover: Sortie 16/345 of Photo Nos: 4204-5  
 30 May 44. Date of Information: 30 May 44.
11. REMY Reference Map: G.S.G.S. 4347/31/16 NE  
 Probable anti-tank position under construction at 885777. There  
 is a perimeter trench approximately 30 feet in diameter.  
 Air Cover: Sortie 400/167 of Photo Nos: 3154/5  
 27 May 44. Date of Information: 27 May 44.
12. STE CHAIS GRATE JUNE Reference Map: G.S.G.S. 4347/31/16 NE  
 Ten small pits at 806756.  
 Air Cover: Sortie 400/162 of Photo Nos: 3151/2  
 27 May 44. Date of Information: 27 May 44.
13. CLISAYNE Reference Map: G.S.G.S. 4347/31/20 SE  
 Fourteen small pits at 3673-120.  
 Air Cover: Sortie 16/345 of Photo Nos: 4030  
 22 May 44. Date of Information: 22 May 44.
14. ANTHONY Reference Map: G.S.G.S. 4347/31/20 SE  
 Twelve small pits at 3595-500.  
 Air Cover: Sortie 16/345 of Photo Nos: 4003  
 22 May 44. Date of Information: 22 May 44.

/14. POINTS

TOP SECRET  
BIGOT

0174

TOP SECRET  
BIGOT

- 3 -

15. POINTE et RAZ de la FERCE Reference Map: G.S.G.S. 4347/34/18 NE

The unspecified infantry weapon shown on the defence overprints at 626933 is now seen to be a light gun, probably 75 mm., in an open emplacement. There is also a small soldier with a Tobruk pit adjoining the emplacement.

Air Cover: Sortie 168/205 of photo Nos: 3012/3  
31 May 44.

Date of Information: 31 May 44.

16. ST. JACQUES de KROU Reference Map: G.S.G.S. 4347/31/18 NW

Probable light Anti-tank gun in an open emplacement at 13509844; it commands the main street. Two new A.T. boys at 133984.

Air Cover: Sortie 1066/516 of photo Nos: 3111/2  
26 May 44.

Date of Information: 26 May 44.

17. RAVENOVILLE Reference Map: G.S.G.S. 4347/31/20 SE

Unoccupied emplacement, probably for an anti-tank gun, at 387012.

Air Cover: Sortie 1066/455 of photo Nos: 4126  
22 May 44.

Date of Information: 22 May 44.

18. PONTAINE HENRY. Reference Map: G.S.G.S. 4347/37/16 NE

A gun, probably Anti-tank, in open emplacement at 955795. Pillbox at 979783.

Air Cover: Sortie 1066/540 of photo Nos: 3152/3 and 3148/9  
27 May 44.

Date of Information: 27 May 44.

19. HERMANNVILLE sur MER Reference Map: G.S.G.S. 4347/40/16 NE

Two light field or Anti-tank guns at 058798 and 049789.

Air Cover: Sortie 16/313 of photo Nos: 4057/8  
28 May 44.

Date of Information: 28 May 44.

20. YAREVILLE Reference Map: G.S.G.S. 4347/34/18 NE

The shelter shown under construction on the defence overprints at 43619902 is now completed. An excavation for a shelter at 43579898.

Air Cover: Sortie 16/328 of photo Nos: 4008 and 3008  
29 May 44.

Date of Information: 29 May 44.

21. MERVILLE-FRANCEVILLE Reference Map: G.S.G.S. 4347/40/16 NE

Six new dugouts in area of 188783.

Air Cover: Sortie 400/170 of photo Nos: 4208/9  
27 May 44.

Date of Information: 27 May 44.

/22. ROUCHEVILLE...

TOP SECRET  
BIGOT

0 1 7 5

TOP SECRET  
BIGOT

- 4 -

22. BOUCHEVILLE Reference Map: G.S.G.S. 4347/40/16 NE  
Thirteen dugouts in area of 164709.  
Air Cover: Sortie 400/170 of photo Nos: 4195/6  
27 May 44. Date of Information: 27 May 44.
23. CHERBOURG Reference Map: G.S.G.S. 4347/31/22 SW  
Trench system on North side of road at 12702340, with five  
branches of trench leading to probable dugouts in the fields.  
Air Cover: Sortie 16/339 of photo Nos: 4008  
30 May 44. Date of Information: 30 May 44.
24. LEAUVILLE Reference Map: G.S.G.S. 4347/43/18 SW  
Pillbox at 45101320.  
Air Cover: Sortie 16/313 of photo Nos: 4096/7  
28 May 44. Date of Information: 28 May 44.
25. OUISTREHAM Reference Map: G.S.G.S. 4347/40/16 NW  
Road loops for vehicles, AFV's or S.F. guns at 100779,  
102776, 104777, 105775 and 100773.  
Air Cover: Sortie 16/313 of photo Nos: 3025 and 4060  
28 May 44. Date of Information: 28 May 44.
26. BRUCHEVILLE Reference Map: G.S.G.S. 4347/34/18 NW  
Four small pits and dugouts at 42773202.  
Air Cover: US 31/483 of photo Nos: 1006/7  
27 May 44. Date of Information: 27 May 44.
27. HEULDATE Reference Map: G.S.G.S. 4347/40/18 SE  
Trench from 25453146 to 25403146 with three fire bays.  
Air Cover: Sortie 16/334 of photo Nos: 3163/4  
29 May 44. Date of Information: 29 May 44.
28. DIVAS-sur-ER Reference Map: G.S.G.S. 4347/40/18 SE  
Pillbox at 23780002.  
Air Cover: Sortie 16/334 of photo Nos: 3158/9  
29 May 44. Date of information: 29 May 44.
- /29. COLOMBELLES....

TOP SECRET  
BIGOT

0176

TOP SECRET  
BIGOT

- 5 -

29. COLLETTES Reference Map: G.S.G.S. 4347/40/16 N  
A possible Anti-tank gun in an emplacement at 064705 with a  
dugout in rear of it.  
Air Cover: Sortie 400/170 of Photo Nos: 3020/1  
27 May 44. Date of Information: 27 May 44.
30. CAEN Reference Map: G.S.G.S. 4347/40/16 N  
Eight new vehicle ways at 014701.  
Air Cover: Sortie 400/167 of Photo Nos: 4408/9  
27 May 44. Date of Information: 27 May 44.
31. ANISE Reference Map: G.S.G.S. 4347/40/16 N  
Approximately twenty small pits widely spaced in a field at  
012762.  
Air Cover: Sortie 400/167 of Photo Nos: 4418-9  
27 May 44. Date of Information: 27 May 44.  
Comment:  
The purpose of these pits is NOT known.
32. POLLIGNY Reference Map: G.S.G.S. 4250/62/5  
A circular pillbox with probable all-round field of fire at  
253343.  
Air Cover: Sortie 2/25 of Photo Nos: 0035  
28 April 44. Date of Information: 28 April 44.
33. CHERBOURG Reference Map: G.S.G.S. 4347/31/22 SW  
A mine has been put up outside the trench along the line of the  
quarry at 1002345.  
Air Cover: Sortie 16/335 of Photo Nos: 3043/4  
29 May 44. Date of Information: 29 May 44.
34. VIERVILLE sur MER Reference Map: G.S.G.S. 4347/34/16 N  
The type 677 casemate which was shown on the defence over-  
prints as under construction at 654912 is now complete.  
Air Cover: Sortie 16/313 of Photo Nos: 4417/8  
28 May 44. Date of Information: 28 May 44.
35. TOUSSAYVILLE Reference Map: G.S.G.S. 4347/31/22 SE  
An underground shelter at 3523285.  
Air Cover: Sortie 16/224 of Photo Nos: 4039/40  
22 May 44. Date of Information: 22 May 44.
- /36. TOUSSAYVILLE..

TOP SECRET  
BIGOT

0177

TOP SECRET  
BIGOT

- 6 -

36. TOONVILLE Reference Map: G.S.G.S. 4347/31/22 SE  
Three long dugouts, or possible A.T. boya, at 35232585.  
Air Cover: Sortie 16/224 of Photo Nos: 4039/40  
22 May 44. Date of Information: 22 May 44.
37. YANOWVILLE Reference Map: G.S.G.S. 4347/31/22 SE  
An excavation, probably for a pillbox, at 32632600.  
Air Cover: Sortie 16/224 of Photo Nos: 4042/3  
22 May 44. Date of Information: 22 May 44.
38. WINDY HILLS Reference Map: G.S.G.S. 4347/31/22 SE  
A casemate, possibly type 677, at 36782746 facing North east.  
Air Cover: Sortie 16/224 of Photo Nos: 4035/8  
24 May 44. Date of Information: 22 May 44.
39. FRANKVILLE LAKE Reference Map: G.S.G.S. 4347/40/16 N  
The foxholes shown on the defence overprints between 142735  
and 143735 are now seen to be of the dugout type and may be used for small  
arms.  
Air Cover: Sortie 16/317 of Photo Nos: 4012 and 4013  
23 May 44. Date of Information: 23 May 44.
40. FRANKVILLE LAKE Reference Map: G.S.G.S. 4347/40/16 N  
A possible MAG at each corner of the ramparts of the old  
fort at 141791. A small emplacement, internal diameter approximately 6 feet,  
inside the fort.  
Air Cover: Sortie 16/317 of Photo Nos: 4013 and 4013  
23 May 44. Date of Information: 23 May 44.
41. LAKE Reference Map: G.S.G.S. 4347/26/20 SE  
There are 5 L.A.G. positions in a line on the shore between  
372065 and 372066 and 3 L.A.G. positions between 372070 and 372073.  
Air Cover: Sortie 140/207 of Photo Nos: 4022/4  
23 May 44. Date of Information: 23 May 44.
42. VILLERS-SUR-LORE Reference Map: G.S.G.S. 4347/43/18 SW  
The shelter which is shown under construction at 30148221 on  
the defence overprints is now seen to be a casemate type 677.  
Air Cover: Sortie 140/157 of Photo Nos: X67  
22 May 44. Date of Information: 22 May 44.

/43. TROWVILLE....

TOP SECRET  
BIGOT

0 1 7 8

BIGOT..

- 7 -

43. TROUVILLE Reference Map: G.S.G.S. 4347/42/13 54  
 Shelter at 45331327.

Air Cover: Sortie 1-0/157 of Photo Map: 4039-40  
 22 May 44. Date of Information: 22 May 44.

44. DREUX Reference Map: G.S.G.S. 4230/93/1

There is a pillbox at 1.5301 defending the entrance to the  
 factory.

Air Cover: None Date of Information: 1 April 44.

45. ARRES Reference Map: G.S.G.S. 4250/06/5

A length of section trench leads to a machine-gun position at  
 547901. Hedge appears to have been cleared to give a field of fire to the  
 West and the North-West.

Air Cover: Sortie 16/241 of Photo Map: 3064/5  
 15 May 44. Date of Information: 28 May 44.

G-2 (I WRELL WORK) DIVISION  
RECAP.

7 June 1944.

TOP SECRET  
 BIGOT

7088  
 0179



TOP SECRET

REPORT ON THE RESULTS OF THE  
INSPECTION OF THE  
DEFENSE INSTALLATIONS  
IN THE AREA OF  
VIETNAM  
Dated 2 June 1944.

TOP SECRET

REPORT ON THE RESULTS OF THE  
INSPECTION OF THE  
DEFENSE INSTALLATIONS  
IN THE AREA OF  
VIETNAM

A. Anti-tank ditches

1. TRUNG-KI-THI, SOUTH LAOKE Ref. No: GCSG 4347, Sheet 24/25  
Compass.

Date of Information: 22 & 27 May 1944.

The anti-tank ditch running roughly Southward from UHNEY to THE  
 SOUTH LAOKE has been extended between the following points, some of the  
 new sections continuing the general zig-zag line, others running East  
 of it to encircle defended localities:- 019270-019282-00285; 017275;  
 038212-038214-037214; 03-225-03223; 003231-002792.

Air Cover: Sortie 106 4/155 Photo nos. 1064 & 3048  
of 22 May 1944.

106 5/518 1253-4 & 3046  
of 27 May 1944.

2. THE NORTH LAOKE AREA Ref. No: GCSG 4347, Sheet 31/18  
NE

Date of Information: 29 May 1944.

An anti-tank ditch 15 feet wide surrounds the strongpoint at  
 43559907 on three sides. Bars or wooden stakes are being laid across  
 the top of the ditch at intervals of approximately 5 to 6 feet, possibly  
 to suggest some type of camouflage covering.

A belt of wire runs along the beach in front of the strongpoint  
 from 4349531 to 4379001.

Air Cover: Sortie 16/328 Photo nos. 4008, 3008, 3009  
of 29 May 1944.

3. VIAH TH-SUN-TH Ref. No: GCSG 4347, Sheet 43/18  
S

Date of Information: 22 May 1944.

Thickly graded air cover shows obstacles, probably vertical rails,  
 in the bottom of the section of anti-tank ditch between 3105045 and  
 3024 375. The ditch is 40 feet wide at the east end and narrows to  
 30 feet in the centre and to 35 feet at the west end. This confirms  
 previous information from ground sources, which also report the ditch  
 to be revetted with concrete and to have sides sloping at an angle of  
 approximately 45°.

Air Cover: Sortie 16/157 Photo nos. 4020-21  
of 22 May 1944.

4. CHONG Ref. No: GCSG 4347, Sheet 40/16  
NE

Date of Information: 29 May 1944.

New sections of the CHONG - ANH-VIEN canal ditch have been  
 dug between the following points:- 20557900-20557900; 195-7890-1927790.  
 A further new stretch, 50 feet long, has been dug since 27 May at  
 1977795.

Air Cover: Sortie 16/337 Photo nos. 3151-3  
of 29 May 1944.

/read block.....

TOP SECRET  
BIGOT

- 2 -

## B. Road Blocks

1.

Ref. Map: GSGS 4347, Sheet 43/183F

Date of Information: 28 May 1944.

The five units of Element 'C' previously standing on the road at 42901195, have now been moved to the side of the road at 42921139. They are standing end to end, as before.

Air Cover: Sortie 16/313  
of 28 May 1944.

Photo Nos. 4091-92

2. QUISTREHAM-ISIRNY

Ref. Map: GSGS 4250, Sheets 62/6 &amp; 72/5

Date of Information: 29 February 1944.

A ground source summarizes the system of roadblocks in the QUISTREHAM-ISIRNY area as follows: Obstacles can be divided into two categories: a) those that block all roads leading from the sea, which consist of reinforced concrete, round-topped walls, 2.5m. high and 75 cm. to 90 cm. thick; and b) those blocking the main coastal road on the outskirts of each village, generally composed of units of Element 'C' or of tracktrucks.

Comment:

Source's summary was fairly sound at the date of information. The demand for Elements 'C' as under-water obstacles, has, however, greatly reduced their numbers on the roads.

3. GRAND HANSAU DES DUNES

Ref. Map: GSGS 4347, Sheet 34/20 ST.

Date of Information: 29 May 1944.

The gap in the wall roadblock at 406033 is now seen to be closed by horizontal girders.

Air Cover: Sortie 16/328  
of 29 May 1944.

Photo Nos. 3022, 4019.

Comment:

Ground sources have frequently reported this combination of obstacles, describing an "iron gate", hinged to the wall at one side, and consisting of two or three horizontal girders which are swung across and locked into sockets in the wall at the other side of the road.

/C. Under-water obstacles

TOP SECRET  
BIGOT

0181

TOP SECRET  
BIGOT

- 3 -

## C. Underwater obstacles

## 1. Attached tracing

Attached is a tracing showing the 1st elements to underwater obstacles on CGS 4490 Sheet 89.

2. SEVILLE

Ref. Map: CGS 4490 Sheet 86

There is a single probable raft, about 300 yards from the coast, at 09100.

Air Cover: Series 40/10  
of 31 May 1944

Photo No. 4490-4

3. SPRINGVILLE

Ref. Map: CGS 4347 Sheet 2/22 Comp.

Our straggling rows of (1) stabs have been set up between 07127 and 08127, on a relatively rocky part of SPRINGVILLE beach. These include a short row of (7) stabs already reported.

Air Cover: Series 16/39  
of 31 May 1944

Photo No. 3111

4. SIQUVILLE

Ref. Map: CGS 4347 Sheet 21/20 US &amp; NI

A short staggered row of six rafts can be seen at 97150, seaward of the Elements 'C'.

Air Cover: Series 16/39  
of 31 May 1944

Photo No. 3157.

C-2 (Intelligence, Division,  
Department)  
7 June 1944.

TOP SECRET  
BIGOT

0 1 8 2

TOP SECRET  
BIGOT

TOP SECRET

Issued with Appendix 'E' to NEPTUNE ARCHES NO. 35 Dated 2 June 1944.

G.E.G.S. 4490. Sheet 85. LAC-SUR-MER. 1:12,500

The information below is additional to that shown on the tracing issued in the NEPTUNE ARCHES NO. 35.

Air Cover: Sortie 16/345 of 30 May 1944.



G-2 (Intelligence) Division,  
SMAAF.  
2 June, 1944.

TOP SECRET  
BIGOT

0 1 8 3

TOP SECRET  
BIGOT

TOP SECRET

APPENDIX 'G' TO NEPTUNE ARGUS No. 36  
Dated 2 June 1944Ammunition Dumps in the NEPTUNE Area

- 1.
- FRANCE: GODERVILLE
- 
- (SEINE INFÉRIEURE)

Ref. Map: 4040A/193-/6942

Date of Information: April 44

Underground installations for storage have been reported at GODERVILLE.

Source: GroundAir Cover: NoneAmendment to: TIS/D.IV/DEF/8.2

- 2.
- FRANCE: CHERBOURG/LES BREVINS
- 
- (MANCHE)

Ref. Map: 4250/635 to 4 (129201)

Included with this number of NEPTUNE ARGUS is a scale drawing of the Powder Factory and Ammunition Dump, which supplements the sketch of this installation issued with TIS/D.III/DEF/8.2, Proforma No: MANCHE/1.

Amendment to: TIS/D.III/DEF/8.2

- 3.
- FRANCE: FORÊT DE LA FERTE
- 
- (ORNE)

Ref. Map: 4040B/62 SW

Date of Information: 12 May 44

Sketch accompanying ground report shows important ammunition dump on both sides of road in forest, and extending for several hundred metres on either side of the road, from approximately 987991 to 999980.

Comment:

This report gives a more exact location for the dump than it was possible to give from previous reports.

Amendment to: TIS/D.IV/DEF/8.2G-2 (Intelligence) Division,  
SHAEP.  
2 June 1944CONFIDENTIAL  
95210TOP SECRET  
BIGOT

0 1 8 4

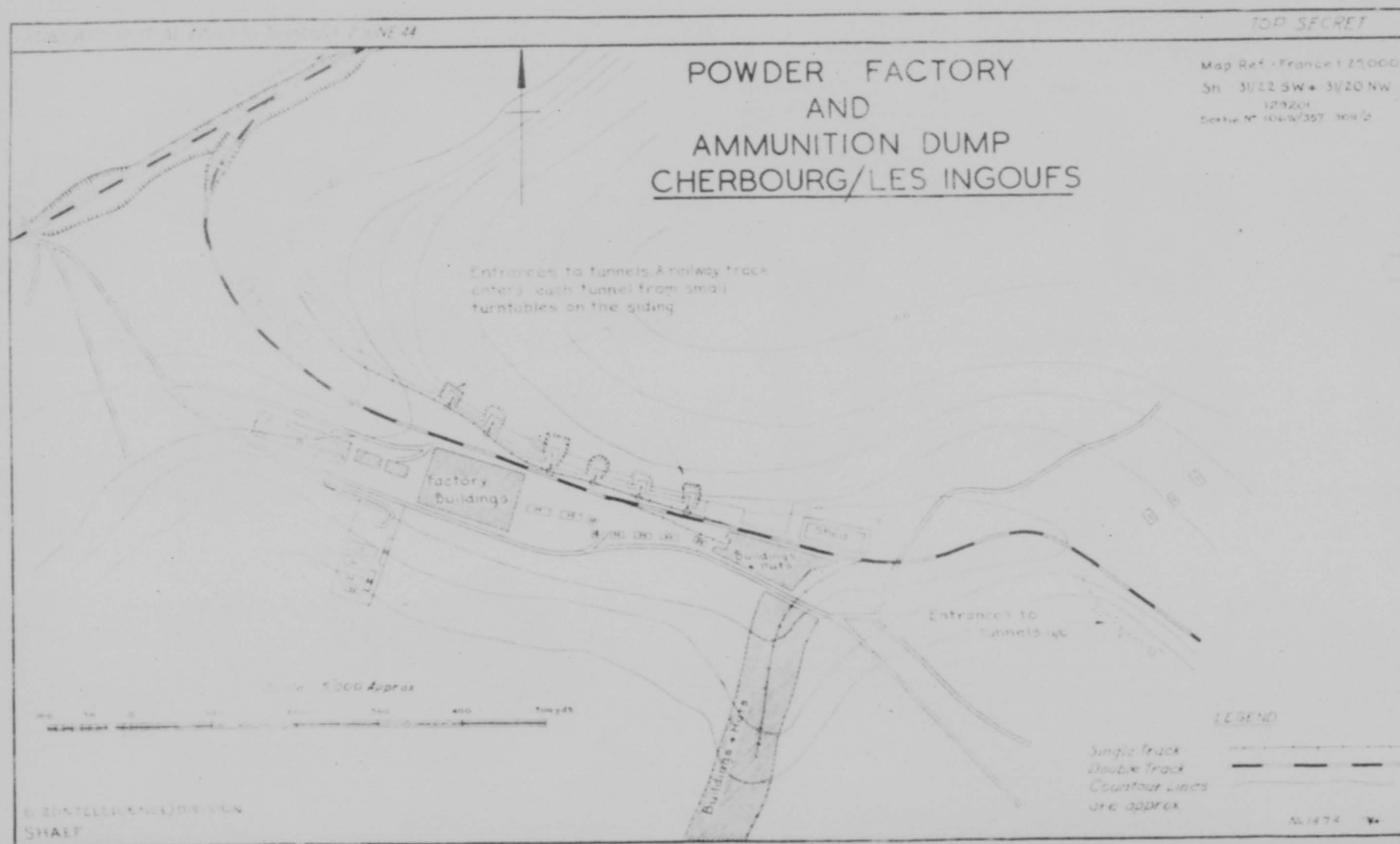

0185



TOP SECRET  
BIGOT

TIS/00/132/1

SURREIN HEADQUARTERS,  
ALLIED TROOPING FORCE,  
G-2 (INT. SECURITY) BRANCH.

TOP SECRET

Copy No. 101

1 June 1944

NEPTUNE ARGUS NO. 35

With this report:

- Appendix 'A' - Artillery
- Appendix 'B' - Naval Installations
- Appendix 'C' - Obstacles
- Appendix 'D' - Signals Installations
- Appendix 'E' - Topography & Inundations

Bombing attack on fuel dump on (26 May 1944).

1. DOORFONT

Reference Map: 4250/781/788070

This target was attacked on 26 May 1944 by 55 Thunderbolts. Cover of 26 May 1944 shows no damage to the target itself, although a bomb has destroyed a nearby house. Hits are seen on the railway line west of the station and on the corner of the wood to the NE of it. A number of the station buildings appear to be burned out as do some houses to the North of the railway line at the level crossing North of the station.

Air Cover: Sertic US/111 of  
26/5/44

Photo Nos: 5001-6

- Supports for mines manufactured at CHERBOURG.

2. A very good source reports that on 8 April 1944 the BIGOT factory at CHERBOURG were manufacturing 9000 supports for teller-mines for use in an anti-tank role and also at sea. (See sketch on separate sheet).

Comment:

It is clear that the report refers to teller-mines mounted on stakes and probably on other underwater obstacles. Re-examination of photo No. 0061 of US 34/420 of 19 May 1944, which was issued with NEPTUNE ARGUS NO. 24, shows clearly these supports in use.

- Constructional activity at LAUF BEHL/LES BRIBES DES AUCRAIS.

Reference Map: 4250/7F4/087520

3. A fair source reports the arrival in Mar 44 of an "enormous gun" the length of which is estimated at 39 m., in the AUCRAIS quarries on the road from CAEN to FALAISE. Considerable underground work has been undertaken for the installation of this gun and also for the storing of ammunition.

CONFIDENTIAL

-/Comment,...

95010

TOP SECRET  
BIGOT

0186

TOP SECRET  
-2-  
BIGOTComment :

Activity at the MOULAIS quarries is confirmed (Sortie 16/37. 3028/29. 23 April 1944). Large camouflaged shelters near railway spurs are seen in this quarry area. Previous reports have stated that galleries leading from the quarry face have been prepared for use as a deep for ammunition or for tanks and M.T. (See NEPTUNE ARGUS No. 2 para 1) but the possibility of a "secret weapon" emplacement at this site has NOT been ruled out. The present report certainly suggests something more than storage.

Transport of Chemical Warfare Material from MOULAIS to the SOMME

4. A usually good source reports the transport of 40,000 mustard gas shells from the MOULAIS area at MOULAIS to the SOMME area in April 1944.

Comment:

The poison gas plant in the MOULAIS State Arsenal was destroyed in the Bomber Command attack of 20/21 March 1944. It is NOT known whether any reserves of mustard were held in the MOULAIS area at the time of the attack. No other reports have been received of the building up of gas stores in the SOMME area.

Offshore Mines

5. Further to NEPTUNE ARGUS No. 34 para 1, the photographs referred to are NOT of waters in the NEPTUNE area. The type of mine described is, however, in general use and liable to be found in the NEPTUNE area.

Possible projector position in the N.E. COTENTIN

Reference Map: GSGS4347  
Sheet 28/20 SE, 024062

6. Photographs of 27 May 1944 show four occupied emplacements about 20 feet in diameter in line in a field alongside the road ST. GERMAIN LE GAILLARD - LA CROIX MOULAIN. The objects in the emplacements have a short thick body and split trails: these features suggest that they may be projectors (artillerie).

Sortie: 31/490 of 27 May 1944.

Comment:

The photographs are of 1/15,000 scale. The possibility of the objects being field guns is NOT excluded. The position appears suitable for projectors however.

Reference Map: GSGS4347  
Sheet 28/20 SE, 037070

7. Photographs also show in the same area a position consisting of four unoccupied emplacements, in staggered layout, in a field off the road ST GERMAIN LE GAILLARD - PIGEON. The emplacements are 20ft across, with an inner diameter 10ft.

Comment :

Likely to be a rough position for field guns, rather than projectors as in para 6 above. The appearance of new artillery positions in this part of the COTENTIN is in any case interesting.

*M. P. Watkins Capt*  
for Major-General.  
A.C. of S.  
G.2.

TOP SECRET  
BIGOT

0187

TOP SECRET  
BIGOT

TOP SECRET

Issued with SECURITY APPROV. NO. 25 dated 1 June 1944

Specs for Mine Manufactured at CHENNING

(See para 2)

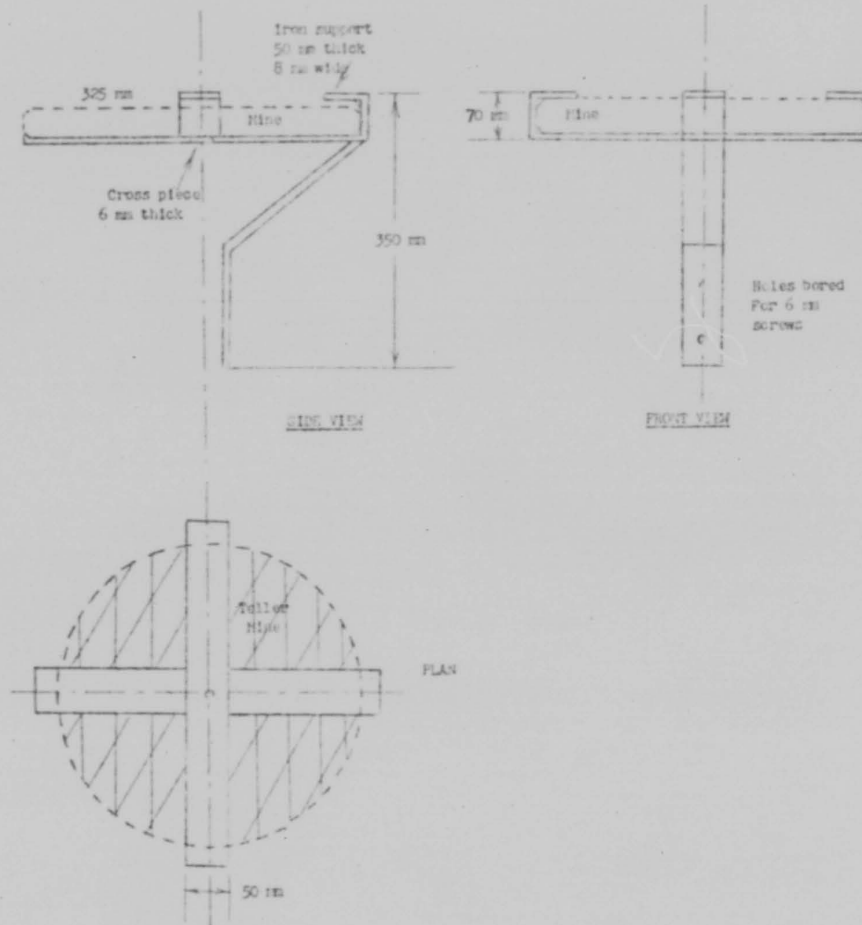

G-2 (Intelligence) Division,  
S. S. S. S.  
1 June 1944

TOP SECRET  
BIGOT

0 1 8 8

TOP SECRET  
BIGOTTOP SECRETAPPENDIX 'A' TO MEMORANDUM ARCHIVE NO. 35  
DATE: 11 JAN 1954Artillery in the HERMAN AreaA. Bomb Damage1. ST. VALERE DE CAUX

Ref. Map: GSGS 4250/SD6/972642

The following is the situation at this six-gun medium battery after a recent bombing attack:

No.1 emplacement and gun appears undamaged, although spoil from a near miss is visible in the emplacement.  
Nos.2 and 3 emplacements are damaged by direct hits. The guns are visible but may be damaged.  
No.4 emplacement has been damaged, and an object in it, possibly the gun, is half buried in spoil.  
No.5 emplacement is half obliterated by a marginal hit. No gun is visible.  
Nos.6 and 7 emplacements are undamaged, and unoccupied.  
Of the four casemates under construction, No.1, in the excavation stage, is undamaged. The excavation for No.2 is half obliterated. The site of No.3 is probably undamaged, despite two near hits within 12 yards. No.4 casemate is complete and appears undamaged despite 5 hits within 50 yards.  
Roads serving the battery have been cut by direct hits.  
Three sunken buildings or shelters at 973646 have been destroyed by direct hits, and two shelters to the rear of No.1 emplacement have probably been damaged.  
Few repairs have been made on the site.

Air Cover: Sortie 1064/558  
of 28 May 1944.

Photo Nos. 3016-7

2. CRIQUEBIEUX

Ref. Map: GSGS 4250/8EL/ 667529

The situation at this six-gun medium battery after recent raids is as follows:

Nos.1 and 2 emplacements are intact and occupied.  
No.3 emplacement was completely demolished by at least 2 direct hits. No gun is visible.  
No.4 is undamaged, and camouflaged, probably occupied.  
No.5 sustained two near misses within 15 yards, but is intact and occupied.  
No.6 is undamaged, camouflaged, probably occupied.  
The three additional emplacements on the site are intact and unoccupied, and the possible anti-tank to the rear of the battery is still in its emplacement.  
Of the two square concrete shelters on the South side of the road serving the battery, one has been completely demolished, the other partly demolished. A large buried shelter immediately in front of the probable C.P. sustained four direct hits, but is apparently undamaged. Considerable track activity is visible on the site.

Air Cover: Sortie 414/172 (Oblique) Photo Nos. 009-011  
of 27 May 1944.

CONFIDENTIAL  
TOP SECRET  
BIGOT

TOP SECRET  
BIGOT

-2-

3. CURSEL

Ref. Map: GSGS 4250/831/535452

The following is the situation at this four-gun medium howitzer battery after recent raids:

All four emplacements are occupied.  
The easternmost of three probable AA machine gun positions in rear of No.4 emplacement has been demolished by a direct hit.  
Two small buried shelters between Nos.3 and 4 emplacements have been obliterated by direct hits, as has the buried shelter in rear of No.1 emplacement.  
One buried shelter in rear of No.4 emplacement has been stripped of its earth covering by two near misses and is probably damaged.  
No repairs or activity are visible on the site since the attack of 20 May.

Air Cover: Sortie 414/175 (oblique) Photo Nos. 0019-21  
of 27 May 1944  
Comparative Sortie 5004-5  
US 12/01 of 20 May 1944

4. VER SUR MER

Ref. Map: GSGS 4250/735/917344

This four-gun casemate battery was bombed for the first time on 26 May. 38 craters are seen within 100 yards of the casemates. Two casemates may have been damaged.

No.1 Casemate - No damage.  
No.2 " - Two near misses. Possible damage.  
No.3 " - Possibly damaged by near misses.  
No.4 " - One possible near miss, but NO apparent damage.  
All four casemates appear complete.  
Road, perimeter wire and communication trenches are damaged.

Air Cover: Sortie 16/334  
of 29 May 1944

Photo Nos. 4055-6

TOP SECRET  
BIGOT

0 1 9 0

TOP SECRET  
BIGOTB. Other Reports1. WINDYVILLE

Ref. Map: GSGS 4250/TP1/265267

From recent photographs, it has been possible to make a fairly accurate estimate of the arc of fire of this four-gun heavy battery. Each gun has an arc of fire of approximately 125°, but because of the slightly different siting of the individual guns, the battery as a whole covers an arc of 145°, from 257° grid bearing to 24° grid bearing.

Air Cover: Sertic 16/214  
of 22 May 1944

Photo Nos. 3021-5

2. WINDYVILLE

Ref. Map: GSGS 4250/7E6/473153

All four casemates of this battery are now complete. Behind the casemates, 9 excavations for shelters are visible. An O.P. forward of the position is still in the excavation stage.

Air Cover: Sertic 16/313  
of 28 May 1944

Photo Nos. 3045-7

3. COCKEVILLE SUR LER

Ref. Map: GSGS 4250/7F2/263786

A new duggy position has been constructed here.

Air Cover: Sertic 400/164  
of 27 May 1944  
Sertic 16/334  
of 29 May 1944

Photo Nos. 4173-4

4145-6

Comment:

A duggy for the medium howitzer battery at 254784, which already has one duggy at 261781.

4. PAVREL

Ref. Map: GSGS 4250/7E6/313816

Seen at this point are two unoccupied emplacements 35 feet in diameter, 65 yards apart.

Air Cover: Sertic 400/164  
of 27 May 1944

Photo No. 4039

5. NORWICHVILLE

Ref. Map: GSGS 4250/6E6/620871

An excellent duggy strongpoint is seen here, including four duggy emplacements and a number of machine gun pits. Trackage is very obvious.

Air Cover: Sertic 16/334  
of 29 May 1944

Photo Nos. 3010-11

6. GATIEVILLE

Ref. Map: GSGS 4250/6E1/382278

A short length of cutting 41 feet long by 9 feet wide is seen here, with a double track leading back to the O.P. at 389278. A roadway leads back from the cutting to WINDYVILLE battery at 392276.

Air Cover: Sertic 16/294  
of 27 May 1944  
Sertic 4/145  
of 30 May 1944

Photo Nos. 4071-2

3008-9

TOP SECRET  
BIGOTComment:

0191



TOP SECRET  
BIGOT

-4-

Comment :

In the recent bombing of C/NEVILLE battery, the track and the O.P. were NOT damaged. A camouflaged structure 28 yards to the South West was demolished.

7. NETT TROT Ref. Map: GSGS 4250/5E1/993223  
The four casemates at this position are now complete, and may be occupied. The four original open emplacements are unoccupied.  
Air Cover: Sortie 106G/518 of 27 May, 1944 Photo Nos. 3238-9
8. VER SUR MER Ref. Map: GSGS 4250/7E5/917844  
The four casemates at this site are complete. There is little sign of activity at the dummy position at 925899.  
Air Cover: Sortie 106G/518 of 27 May 1944 Photo Nos. 4019-20
9. BEANVILLE Ref. Map: GSGS 4250/5E2/015248  
The four casemates at this site appear completed.  
Air Cover: Sortie 106G/517 of 27 May 1944 Photo Nos. 3218-9
10. RENNESVILLE Ref. Map: GSGS 4250/7E6/  
Date of Information: 24 Mar 44

A good source reports the artillery in this area to consist of 2 batteries of 155 mm guns, 1 battery of 155 mm howitzers, 1 battery of 105 mm guns, 2 batteries of 77 mm guns, and 1 L.A. battery.

Comment :

This report is probably correct. The batteries are as follows:

1. WILLERVILLE (460156) 6 (or 4) 155 guns.
2. REBERNEVILLE (473153) 4 x 155 guns. Previously listed as 4 x ? 105 gun-howitzers, but there have been previous indications that this may be a medium coast battery. The casemates are 32 feet by 35 feet, and could house medium guns.
3. LE BLONCIR COAST BATTERY (460149) 4 x 155 Howitzers. Previously listed as 4 x 105 howitzers.
4. BRUYERE BATTERY (473141) 4 x 105 gun-howitzers. Previously listed as 4 x ? 150 howitzers.
5. CANNONVILLE I (473111) 4 x 77.
6. CANNONVILLE II (473112) 4 x 77. Previously listed as 4 x ? 75. There have been some doubts about the authenticity of this position.
7. NO heavy L.A. battery has been seen in this area, but there are at least twelve light L.A. guns and two searchlights.

C-2 (Intelligence) Division

SECRET

1 June 1944.

TOP SECRET  
BIGOT

0192

TOP SECRET  
BIGOT

TOP SECRET

APPENDIX 'D' TO REPORT ARGUS NO. 35  
DATED 1 JUNE 1944NAVAL INSTALLATIONSCRANES1. CAEN, TROUVILLE Date of Information 5 February 1944

The Germans are dismantling the cranes of CAEN and TROUVILLE.

(a) CAEN - Air Cover

BR/134 of 6 Feb 44, photo nos. 2022 to 2035  
 140/80 of 3 May 44, photo nos. 3004 to 3006, 4003  
 140/79 of 3 May 44, photo nos. 3001  
 BR/134 of 26 Apr 44, photo nos. 4032 to 4036,  
 3035 to 3037  
 BR/61 of 14 Jan 44, photo nos. 1022 to 1028  
 2021 to 2026

(b) TROUVILLE - Air Cover

BR/338 of May 43, photo nos. 5036 to 5037  
 140/157 of May 44, photo nos. 4039 to 4040  
 1066/407 of May 44, photo nos. 3016 to 3017

(a) CAEN - Comment:

No decrease is seen at CAEN between 6 Feb 44 and 3 May 44. Older good quality cover not available. Cranes seen are as follows:

In enclosure on QUAI DE JUILLET - 1  
 BASSIN ST. PIERRE - 4  
 CHANTIER NAVAL FRANCAIS - 7 possibly 8  
 PORT DE LA S.M.N. - 3  
 NOUVEAU BASSIN (including the section of canal leading into the BASSIN ST PIERRE) - 19

Though cover does not confirm, the dismantling of cranes at CAEN has been reported twice.

(b) TROUVILLE - Comment:

In May 1943 four large cranes were seen on air cover at TROUVILLE. In May 1944 only two are seen.

NAVAL HEADQUARTERS2. RENNES Date of Information 5 May 1944

At RENNES there are German naval headquarters in the Ave. Janvier. They are said to be U-boat headquarters.

Comment:

This establishment is in the LYCEE (Garcons) and has been reported before as a U-boat headquarters. As U-boats are directed operationally from ANGERS, it is probable that this establishment deals with the naval stores at RENNES. These have been considerable, but are now being moved to POITIERS.

G-2 (Intelligence) Division,  
 SHAEF.

CONFIDENTIAL

TOP SECRET  
BIGOT

0193

TOP SECRET  
BIGOT

TOP SECRET

APPENDIX 'E' TO NEPTUNE ARGUS NO. 35  
Dated 1 June 1944.Underwater Obstacles in the NEPTUNE Area1. List of tracings

The following list of current tracings of underwater obstacles issued in NEPTUNE ARGUS supersedes the list given in paragraph 1 of Appendix 'E' to NEPTUNE ARGUS NO. 22, dated 19 May 1944. Sheet numbers all refer to the series C.S.G.S. 4490 (1:12,500).

Sheet No.	Location	Original Tracing in ARGUS NO.	Amendments in ARGUS NOS.
69	ARREVILLE-ST-SAINE	25	27, 32
70	ST VAAST-LA-ROUGHE	33	-
71	QUINEVILLE	21	27, 28
72	TONNERAY	21	27, 28, 33, 35
73	POULVILLE	28	33, 34
74	AUDOVILLE-LA-HUBERT	15	19, 23, 27, 28 33, 34.
75	BREVAUDS	-	-
76	ISIGNY	27	-
77	GRANDCAMP	24 & 27	27
78	ST PIERRE-DU-MONT	-	-
79	VIENVILLE	29	33, 35
80	COLLEVILLE	27	29, 33, 35
81	PORT-EN-BESSIN	-	-
82	ANTOINANCES	5	15, 27
83	VER-SUR-MER	31	32
84	PERNIERES	30	33, 34
85	LUC-SUR-MER	35	-
86	OMISTREHAM	34	-

2. Amendments to NEPTUNE ARGUS No. 34, Appendix E.

(a) The unnumbered tracing issued last night referred to sheet 86, LUC-SUR-MER.

New tracings for this area are issued with this report. It will be noted that the 19 rafts reported last night include those previously shown in the area of 032846.

(b) Tracing "A" (West) of Sheet 86, OMISTREHAM. For "2 rows stakes (? ramps incl)" read "2 rows stakes (? ramps u/o)"

3. OMNEVILLE-LA-PETITE. Ref Map C.S.G.S. 4347/28/22 Composite. 2 staggered rows of obstacles, possibly ramps and/or tetrahedra, run from 954317 to 959316.

Air Cover Sortie 140/207 of 28 May 44. Photo Nos. 4004-6.

4. HAVRE DE PORTAUL. Ref Maps C.S.G.S. 4347/28/18 NE & S.E. The following information is extracted from F.U.S.A. First Phase Interpretation Report No. 18, dated 27 May 44:-

Obstacles, probably Element 'C', run from 03759096 to 04378989. Obstacles previously reported South of 04258990 now extend northwards to 03919035.

Air Cover Sortie 30/4014 of 24 May. Photo Nos. 2074-5 & 5044. (Not yet received at T.I.S.)

TOP SECRET  
BIGOT

95A/10

-5/.....

0194

TOP SECRET  
BIGOT

-2-

5. Unidentified Objects at GRAND HAVREAU DES DUNES. Ref Map G.S.G.S. 4490/72 Between 40270400 and 40953700 cover of 31 May 44 shows 21 white spots in 3 parallel staggered rows. (See tracing attached). The front row, consisting of 5, is sited between the 1st and 2nd rows of hedgehogs in the southern part of this area. The second row, consisting of 6, is sited behind the 2nd row of hedgehogs in the southern part of the area and overlaps to run between the 1st and 2nd rows of hedgehogs in the northern part. The third row, consisting of 8, runs behind the 2nd row of hedgehogs in the northern part of the area and extends seawards for about the same distance as the 2nd row of spots. Spacing between rows varies from 45ft to 50ft, and between spots from 40ft to 56ft.

Air Cover Sortie US 30/4047 of 31 May 1944. Photo No. 2046.

Comment :

The poor quality of the sortie makes it impossible to say what these spots are. They appear to contain a small black object. They may be due to disturbance of the sand caused by blowing holes for the erection of stakes, but this cannot be confirmed.

6. UPVILLE-HAGUE. Ref Map G.S.G.S. 4347/28/22. Composite 2 rows of ramps run seaward of the previously reported single row of tetrahedra or hedgehogs from 050221 to 054281.

Air Cover Sortie 16/22 of 19 May 1944. Photo No. 3113.

7. BEAU GUILLOT. Ref Map G.S.G.S. 4490/74. Between 45549603 and 45279597 4 unidentified objects are seen at the back of the beach.

Although no underwater obstacles are seen south of this, there is track activity on the beach in the area 456959 - 457257, and more tracks issue from the strongpoint at 4566535 and extend seawards on the beach for a distance of some 300 yards from the shore.

Air Cover Sortie US 30/4042 of 31 May 44. Photo No. 1157.

8. GRAND HAVREAU DES DUNES. Ref Map G.S.G.S. 4490/77. A single unidentified unit, possibly an obstacle, is seen at each of the following points:- 51089299, 51229300, 51249301 and 51289399.

Only a few of the scattered units of Element 'C' (53499362 to 54629350) can be identified by careful plotting from comparative cover.

Air Cover Sortie US 30/4045 of 31 May 44. Photo Nos. 2148 and 2141.

Comment :

Although there is a possibility that some of these units may have been removed, this impression may be due to the very poor quality of the sortie.

9. HOUUGATE. Ref Map G.S.G.S. 4347/40/18 SE. A possible belt of underwater obstacles of unspecified type runs parallel with the railway embankment and 100 feet from it between 236803 and 237804.

Air Cover Sortie 16/334 of 29 May 44. Photo Nos. 3159 - 60

G-2 (Intelligence) Division,  
S.H.A.E.F.  
1 June 1944.

TOP SECRET  
BIGOT

0 1 9 5

TOP SECRET  
BIGOT

TOP SECRET

Issued with Appendix "A" to NEPTUNE ANGUS NO. 25 dated 1 June 1944

SECRET. PHOTO FROM THE NATIONAL I/O DIVISION

The information below is additional to that shown on the tracing issued in NEPTUNE ANGUS NO. 25

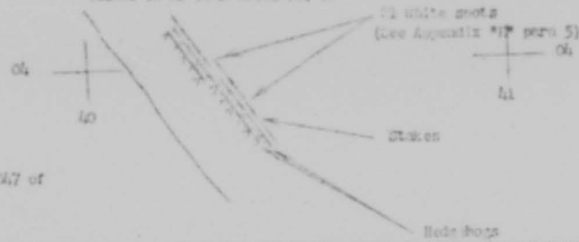

Sortie 30/30/427 of  
31 May 1944

SECRET. PHOTO FROM THE NATIONAL I/O DIVISION

The information below is additional to that shown on the tracing issued in the NEPTUNE ANGUS NO. 27



Further extension of ramp-type  
obstacles clearly spaced between  
the elements "C".

Sortie 30/30/425 of  
31 May 1944. Photo No. 2057-5  
(Quality rather poor due to halation)

SECRET. PHOTO FROM THE NATIONAL I/O DIVISION

The information below is additional to that shown on the tracing issued in the NEPTUNE ANGUS NO. 29

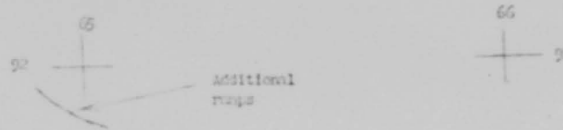

Sortie 30/30/426 of 31 May 1944  
Photo No. 1126 - 8  
(Quality rather poor due to halation)

0-2 (Intelligence) Division,  
S.S.A.B.F.  
1 June 1944

TOP SECRET  
BIGOT

0196

TOP SECRET  
BIGOT

TOP SECRET

Issued with Appendix 2 to REPORT NUMBER 10, 25 dated 1 June 1944  
 Subclass. 1000. Sheet 50. IAW FOR PER 102, 200. Version "A". (100451)

This tracing shows the all previous traces  
 and includes of this subject.

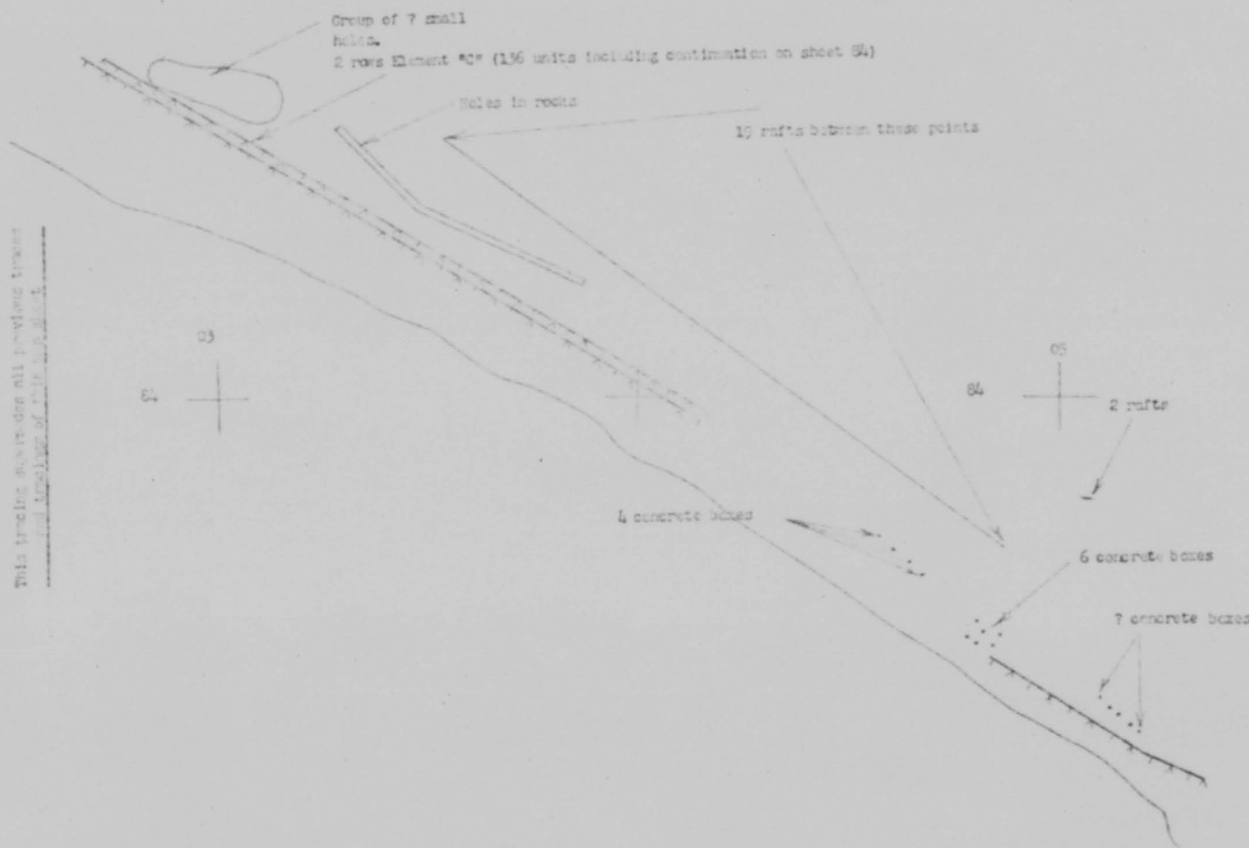

0-2 (Intelligence) Division,  
 S.H.H.F.,  
 1 June 1944

TOP SECRET  
BIGOT

0197



TOP SECRET  
BIGOT

R.I. FROST

Issued with Appendix 1A to MEMORANDUM FOR THE DIRECTOR, dated 1 June 1954.  
Subj: MAP OF THE AREA AROUND THE TETRAHEDRA (SECRET)

This tracing reproduces all previous traces and  
amendments of this map.

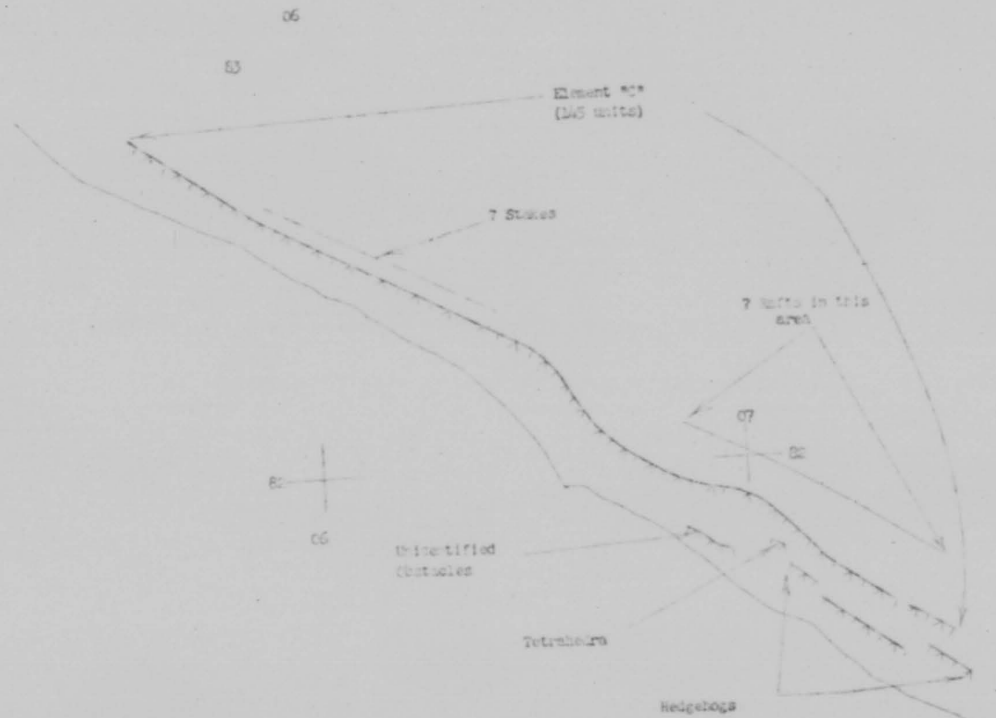

G-2 (Intelligence) Division,  
S. H. H. F.  
1 June 1954.

TOP SECRET  
BIGOT

0198

TOP SECRET

TOP SECRET.

APPENDIX 'I' TO NEPTUNE AREA NO. 25  
Dated 1 June 1944.Signals Installations

1. LISIEUX (CALVADOS) Reference Map: 4250/8P1/534889  
At the barracks, formerly GREENS DETACHMENT, now WESTMARK, occupied by 300 G.A.F. is a radio post, with two telephone lines and a sentry.  
Air Cover: None Date of Information: March 1944  
(uncertain)
2. ORREC/LA ROSIERE (CALVADOS) Reference Map: 4250/8P3/606775  
A new detection post has been installed at LA ROSIERE.  
Air Cover: None Date of Information: March 1944  
Comment:  
This would appear to be an aircraft reporting post and as such would be probably equipped with wireless. It appears that the location is that shown on the map as LA ROSIERE.
3. ORBEC (CALVADOS) Reference Map: 4250/8P3/653732  
A detection post has been installed at No. 1, RUE AUX BOEUFs.  
Air Cover: None Date of Information: March 1944.  
Comment:  
This would appear to be an aircraft reporting post and as such would probably be equipped with wireless.
4. PALAISE/MON DU MARAIS (CALVADOS) Reference Map: 4040B/45 SE/108369  
Just South of the BOIS DU ROI, 2 miles WNW of PALAISE. Two masts 204' high 305' apart, in a line bearing 104° true. Midway between the masts is a building 25' x 18'. Two more buildings are to the south of the masts.  
Air Cover: Sortie 1063/288 of Photo Nos: 3427  
7 May 1944 Date of Information: 18 May 1944  
Comment:  
Other sources state that this is an M/T beacon.
5. AULNAY SUR ITON (EURE) Reference Map: 4040A/47 N/129661  
4 1/2 miles SW of EVREUX. 1/2 mile N.E. of AULNAY-SUR-ITON. Possible mast SE of small chateau building, in grounds of which are several huts of a military type.  
Air Cover: Sortie 88/503 of Photo Nos: 3252  
24 March 1944 Date of Information: 18 May 1944  
Comment:  
Other sources have located an important W/T installation and telephone exchange at this site.

/6. DOMALAIN....

CONFIDENTIAL

TOP SECRET

0199

TOP SECRET  
BIGOT

6. DOMLAIN (ILLE ET VILAINE) Reference Map: 4040B/91 N./329391  
 On the belfry of the church at DOMLAIN the Germans have installed an observation post for aircraft. There are six men there, with a telephone connecting the belfry to an occupied house.  
Air Cover: None Date of Information: 6 March 1944  
Comment:  
 It is NOT stated whether their equipment includes wireless. Aircraft posts of this type are, however, generally equipped with wireless.
7. ST. JEAN DE LIGNERES (MAINE ET LOIRE) Reference Map: 4040B/105 SE/745776  
 Possible V.H.F. wireless installation under construction.  
Air Cover: Scutte 16/147 of 9 May 1944. Photo Nos: 3045/6  
Date of Information: 15 May 1944  
Comment:  
 Other sources reported, some time ago, that a wireless station of unknown type, employing 50 Germans, was at this place.
8. ST. GEORGES-SUR-LOIRE (MAINE ET LOIRE) Reference Map: 4040B/105 SE/672728  
 In grounds of SERRANT CHATEAU,  $\frac{1}{2}$  mile NE of ST. GEORGES-SUR-LOIRE. Two masts 33' tall, 84' apart. A building 160' x 43' to W. of masts.  
Air Cover: Scutte L./913 of 27 March 1944 Photo Nos: 5002  
Date of Information: 15 May 1944  
Comment:  
 This appears to be a V/T station still under construction.
9. PARIS/EIFFEL TOWER (SEINE) Reference Map: 4250/10 P5/013432  
 Opposite the Eiffel Tower, in MAISON D'INTERVAL is a television centre, with an important installation and working with aircraft in relays.  
Air Cover: None Date of Information: 2 April 1944  
Comment:  
 The well known broadcasting wireless station of the EIFFEL TOWER was, according to previous reports, believed to make television and other short range broadcasts.
10. PARIS (SEINE) Reference Map: 4250/10 P5/017448  
 Since 12 January 1944 a new transmitter "L'INFORMATION PERMANENTE, PARIS", has been working. Situation; 116 BIS, AVENUE DES CHAMPS ELYSEES. It can broadcast on several wavelengths, and in event of emergency is meant to broadcast to the PARIS REGION.  
Air Cover: None Date of Information: April 1944.  
Comment:  
 Location confirmed. Details of functions new. /11. GRIGNY....

TOP SECRET  
BIGOT

0 2 0 0

TOP SECRET  
BIGOT

11. GRIGNY (SEINE ET OISE) Reference Map: 4250/10 G2/047210  
 There is a V/T station for the Air Force on the north side of the road from GRIGNY to MORNAY-LE-VAL-CHATEL.  
Air Cover: None Date of Information: 17 February 1944  
Comment:  
 The pinpoint given is only approximate. A further report added that the station was used for G.P. communications only, and had no connection with landing or broadcasting.
12. JOUY-EN-JOUELS (SEINE ET OISE) Reference Map: 4250/10 G1/916335  
 Near the CHATEAU DE LAFFOLE is a wireless post with two masts 20' high, transmitting for all the airfields in the Parisian district and for all the aircraft leaving them.  
Air Cover: None Date of Information: 19 January 1944  
Comment:  
 This has previously been mentioned as aircraft reporting centre.
13. TRARRES (SEINE ET OISE) Reference Map: 4250/10 F5/7836  
 At TRARRES the Germans are proceeding actively with the construction of an important radio-gonio centre; this has been untouched by recent bombing.  
Air Cover: None Date of Information: 23 April 1944  
Comment:  
 No details of location are given, and, pending further information it is possible that the report might refer to an installation already recorded as near MUREUX.

G-2 (INTELLIGENCE) DIVISION  
 SHAEF.  
 1 June 1944TOP SECRET  
BIGOT

0 2 0 1

TOP SECRET  
BIGOT

TOP SECRET

APPENDIX 'L' TO NEPTUNE ARGUS NO. 35.  
Dated 1 June 1944.Toxicity and InundationsInundations in NEPTUNE AREA.Reference Maps: GSGS 2738, Sheets  
3A & 8, 1:250,000  
GSGS 4250/Sheets  
6A/3 & 4, 6E/5,  
5F/2, 6H/1, 6E/6,  
6F/2, 1:50,000.

I. Reference is made to the photographs enclosed in NEPTUNE ARGUS NO. 35, 30 May 1944. The following comments indicate the extent to which flooding as shown on the photographs, has altered since previous reports:-

1. River Saire.

Considerable drying has occurred since the last report made in NEPTUNE SUPPLEMENT NO. 8, 10 February 1944. Flooding has subsided and now the area is a patchwork of lightly flooded fields interspersed with wet, boggy ground. The entire area still remains a complete obstacle to cross-country movement. The embanked road running across the valley between LE CARREFF GOT and DOUET now appears free of flood.

2. GRANDCAMP LE SAINE.

Slightly drier than before but remains a complete obstacle to cross-country movement.

3. East Coast of OCTUBRY.

Remains the same as reported in APPENDIX 'L', to NEPTUNE ARGUS NO. 17, 14 May 1944, which stated that whereas the limits of the flooded area remain generally the same, the depth of flooding has decreased throughout, causing a patchwork of lightly inundated fields interspersed by fields containing wet, boggy ground and water filled ditches.

4. RIVER SAIRE.

Flooding has slightly increased in area and depth since last reported in NEPTUNE SUPPLEMENT NO. 15, 30 March 1944. Details of the present state of flooding are available in Engineer Intelligence Despatch, Area File F & L, sub-file J. The chief effect has been the flooding of all roads in or on the edge of the inundated area. The railway crossing the area is still free of flood.

5. GRAND VEY ESTUARY.

Patches of flooding have occurred along GRAND VEY estuary. This area has previously been reported as floodable. The areas flooded are in the squares 4589, 4090, and 4009.

6. Rivers DOUVE, BERDERET and the PRAIRIES A. RECAUGEUS DE GORGES.

Flooding has been extended 1000 yards up the BERDERET from a dammed rd. bridge at 305995. The valley bottoms upstream from this area are in a wet and boggy state. Damming under the

/road bridges ....

TOP SECRET  
BIGOT

0 2 0 2

TOP SECRET  
BIGOT

- 2 -

road bridges at 159909 and 149349 has lightly flooded the PRAIRIES  
MARTINIERES upstream as far as NEUVILLE EN BASSANT, 150910 and ST.  
SAVIER DE PIERRE PONT, 147856.

7. Rivers VIRE and SAUTE.

Flooding along the River VIRE NE of ST. JEAN DE D'AYE, as  
last reported in REFERENCE NO. 15, 30 March 1944, seems to  
be subsiding but this may be accountable to the poor tone of the  
photos. The appearance now given is lightly flooded areas bounded  
by wet, boggy ground.

Flooding along the River SAUTE and VIRE AT SAUTE canal as  
last reported in REFERENCE NO. 9, 6 May 1944, is now seen to  
extend from GRID REF 3064, to the SE as far as 403782 and South as far  
as 390765 and 405745. This area has always been known to be flood-  
able. The tone of the photographs is poor but the appearance is  
given of thin sheet flooding broken by wet, boggy ground to the SE  
and South, becoming almost continuous sheet flooding in the North  
near CARENTAN.

G-2 (INTELLIGENCE) DIVISION

SECRET  
1 June 1944.

TOP SECRET  
BIGOT

0 2 0 3



TOP SECRET  
BIGOTTIS/CG/132/1.SUPREME HEADQUARTERS  
ALLIED EXPEDITIONARY FORCE  
G-2 (INTELLIGENCE) DIVISION.TOP SECRETCOPY NO: 1013 June 1944

---

N E P T U N E A R G U S NO: 37

---

## With this Report:

- Appendix 'A' - Artillery
- Appendix 'B' - Flak
- Appendix 'E' - Obstacles
- Appendix 'F' - Minefields
- Appendix 'G' - Ammunition Dumps
- Appendix 'I' - Signals Installations

Underwater Obstacles : Concrete Boxes

1. A good source reports that five light naval vessels ("Avisos") were loaded at BORDEAUX on 7 and on 10 May 1944 with 40 mines each voyage. The mines consisted of 1-metre cubes of cement containing each 50 Kg. of cheddite.

Comment:

This report probably refers to the concrete boxes which were reported as being made at BORDEAUX in paragraph 2 of NEPTUNE ARGUS No.36. The use of naval vessels suggests at first that the mines are intended for use below low water mark and that they are of a type similar to those reported, but not yet confirmed, at DIEPPE. (See paragraph 3 of NEPTUNE ARGUS No.31). It is considered more likely, however, that the mines are for use on the beaches, as reported in last night's ARGUS, and that the naval vessels are used for want of other means of transport. Cheddite cannot be connected with any known form of German underwater explosive.

2. (a) Another source reports on 30 May 44 that four Belgian contractors have each obtained an order for 4,000 reinforced conical concrete blocks of about 2 cubic metres in volume. The blocks have an inner cavity for a mine and a stake or section of rail protruding from the top. They are intended to be laid near the water at low tide.

(b) The same source reports that at ZEEBRUGGE 360 concrete blocks have been laid on the beach between the mole and the harbour entrance. These blocks are shaped like pyramids. Each block has three triangular sides, 2 metres at the base and 2 metres 50 high, and is topped by a stake 50 centimetres long.

TOP SECRET  
BIGOT

/Comment:..... 1722

0 2 0 4

TOP SECRET  
BIGOTComment:

This is the first report either of conical or of pyramidal blocks. There is as yet no confirmation for either. The first report seems likely, the second, improbable. The only likely purpose of a stage projecting from the block would be to operate an explosive charge, and it is difficult to believe that such large blocks would be used for this purpose. Blocks shaped like truncated pyramids have been seen on beaches North of the SUEME (see photo no. 0079 of US 31/431 of 20 May 44, which was issued with MARTIAN REPORT NO.97, dated 24 May 44).

3. Shallow pits along the roadside at QUETTEROU.

Reference Map: GSGS 4250, Sheet 6E/364

Partial destruction of a hedgerow from 35071394 to 34981366 shows, where the hedge has been blown away, a number of shallow square pits follows the line of the hedge which is parallel to the coastline and about 300 yards West of the MORSALINES battery.

Unlike the similar shallow pits reported in NEPTUNE ARGUS No.16, paragraph 3, these appear to have camouflaged contents which are stacked in such a way as to leave a narrow gap between the stack and the wall of the pit.  
(Sortie 16/358, photo nos. 3034, 4029, 31 May 1944).

Comment:

Contrary to what was said in NEPTUNE ARGUS No.16, paragraph 3, it is possible that the pits are used for storage purposes.

4. Radar at BAYEUX/LE MESNIL

Reference Map: GSGS 4250, Sheet 7E/5

A Coast watching Radar station has been installed at 783676. (Sortie U.S. 31/419, photo no. 0127, 19 May 1944).

5. Heavy Flak at BAYEUX

Reference Map: G.S.G.S. 4347/37/16 SW

On recent air-cover heavy Flak is seen for the first time in the vicinity of BAYEUX. A 4-gun heavy position is being constructed at 799814: nearby, at 800814, the two attendant light guns are already in position, and a probable SL position is under construction at 801813. Further East, at 837808, are six heavy AA guns in rough earth emplacements: with these, at 836808, are two, possible three light AA guns and, at 836807, a probable searchlight. Between these two heavy positions is an unoccupied heavy Flak site at 812811. Tracks suggest that the guns have been in position quite recently. A fourth heavy Flak site is at VIEUX PONT, (846762) some 4 miles SE of BAYEUX. This contains, at the date of cover (2 June) only three unemplaced guns, which appear to have been only just placed in position.

In addition to the heavy guns noted above, about thirty light AA guns have been deployed near BAYEUX (see Appendix 'B'). It is probable that an entire mixed battalion has been brought up for the defence of the area.

Air Cover: Sortie 30/4046 of 31 May 44. Photo Nos: 5052-5,  
5059-60,  
4059,  
3042.  
Sortie 400/192 of 2 June 44.

*James Phaul* /s/ Lt  
Major-General,  
A.C. of S.  
G-2.

TOP SECRET  
BIGOT

0 2 0 5

TOP SECRET  
BIGOTAPPENDIX 'A' TO FIELD NO. 57  
PART I - DATA

APPENDIX

FIELD NO. 57

1. BURTON

Ref. Map: G.S.G.S. 4250/584/026056

On indistinct cover, three emplacements 20 feet in diameter are visible here, apparently occupied by objects averaging 10 feet in overall length. A fourth emplacement similarly occupied is seen at 025056.

Air Cover: Sortie 16/362 Photo nos. 3033  
of 31 May 1944.

Comment:

This site is in an area where possible WEAPERS have recently been reported. The nature of this position is NOT known, but WEAPERS must be considered a possibility.

2. BEVILLE

Ref. Map: G.S.G.S. 4250/771/059745

Three of the four emplacements previously reported here are now occupied by objects 6 feet long placed well forward in the emplacements.

Air Cover: Sortie 400/132 Photo nos. 4080-1  
of 30 May 1944.

Comment:

Possibly a WEAPERS battery.

3. BEVILLE II

Ref. Map: G.S.G.S. 4250/771/063747

Constructional activity visible here suggests first stages of construction of three emplacements.

Air Cover: Sortie 400/132 Photo nos. 4080-1  
of 30 May 1944.

4. BOLEWICH

Ref. Map: G.S.G.S. 4250/755/

Correct map reference of this possible battery is 833820. Map reference is incorrectly given as 833820 on page 21 of summary of HEAVY ARTILLERY IN THE WESTERN AREA, issued with REPORT NO. 34 of 31 May.

5. The following report has been received from First U.S. Army and it is published without comment. The sortie used has NOT been received by U.S.

a) Ref. Map: G.S.G.S. 4547/34/18 ST/45908195, 46018189  
46068205, 46228216

Four unoccupied emplacements, three in line, one to rear. Attempts have been made to camouflage Nos. 3 and 4.

Air Cover: Sortie US 30/4031 Photo nos. 2006-7  
of 27 May 1944.

/b) Reference Map .....

CONFIDENTIAL

TOP SECRET  
BIGOT

95A10

0 1 9 3  
0 2 0 6

TOP SECRET  
BIGOT

- 2 -

- b) Ref. Map: G.S.G.S. 4347/31/14 18/66 pinpoint reported  
Possible field battery position in hedge. Four open  
emplacements in line.

Air Cover: Sortie US 30/4051 Photo nos. 1015-6  
of 27 May 1944.

- c) Ref. Map: G.S.G.S. 4347/31/16 18/3130705

Six positions along a hedge row, connected by a path.  
Position was probably used by a field battery on occasion.  
They are unoccupied, although the general area shows signs  
of activity.

Air Cover: Sortie US 30/4051 Photo nos. 1058-9  
of 27 May 1944.

G-2 (Intelligence) Division,  
Signal.  
3 June, 1944.

TOP SECRET  
BIGOT

0 1 7 0  
0 2 0 7

TOP SECRET  
BIGOTAPPENDIX 'B' TO REPORT PAGE 18, 37  
Data 1 Page 37

TOP SECRET

Fish in the BOTTLE / etc.

SWERBY (4250/50/3) 255070 251672	Delete CL. Delete SL.	U.S. 109/334. 27 May 44.
ORRIS (4250/30/3) 75003 75005 75006 75007 75008 75009 75010	3 lt occupied. 3 lt. 1R SL. Possible SL. 3 lt. Possible 1t SL.	106G/547 27 May 44.
HENRY (4250/30/4) 813701	SL now occupied.	106G/547 27 May 44.
BRUNNEN (4250/30/6) 06550 06551 06552 06560	3 lt now u. 3 lt now u. 3 lt and 1t SL now u. 3 lt.	U.S. 33/479 27 May 44.
GENULLY (4250/74/5) 923014	Possible 3 lt.	106G/330 27 May 44.
TROPHY (4250/70/2) 118794	Possible 3 lt.	106G/336 20 May 44.
PIERS (4250/70/5) 84216 84218 853001	3 lt. 3 lt. 3 lt.	106G/479 25 May 44.
ALBROOK (4250/70/4) 315050	Possible 4 hy u/c.	106G/514 26 May 44.
CHIROGUS (4250/62/1) 159045	3 lt.	106G/517 27 May 44.
VALGREN (4250/62/3 & 4) 171199	6 hy now occupied.	106G/516 26 May 44.
LANE (4250/62/2) 83400	2 lt on towers	106G/524 29 May 44.
REARMENT-HAGUS (4250/52/2) 056238	SL now u.	106G/540 27 May 44.
ISA PIER (4250/50/4) 111151 111149	4 hy u. 3 lt u.	106G/517 27 May 44.

TOP SECRET  
BIGOT

/RECES...

0 2 0 8

TOP SECRET  
BIGOT

REDDON (4042/75 SD) 046339	3 lt.	U.S. 7/1957 27 May 44.
967515	6 hy, 1 u.	1066/357 29 May 44.
979497	3 lt all occupied.	
970498	Delete 3 lt.	
971498	3 lt u.	
972498	3 lt.	
977473	14 SL.	
958500	3 lt u.	
958497	3 lt, 1 u.	
967157	4 hy now 1 u.	
945290	2 possible SL's now 1 lt.	
948490	3 lt.	
971147	3 lt now u.	
971486	3 lt now u.	
960478	Possible 14 SL.	
960422	3 lt all occupied.	
952433	3 lt u now possibly 2 occupied.	
977530	2 lt now 3 lt.	
985940	Delete 3 lt u.	
905545	3 lt now u.	
001553	Delete 3 lt.	
MERVILLE-FRANCOVILLE (4347/40/16 NT) 153774	4 lt now 3 lt and SL.	16/259 24 May 44. 3017-8.
CAE (4347/40/16 NT) 024707	4 hy, 3 lt and SL, re-occupied on 3 May 44, now unoccu- pied.	400/102 30 May 44. 4086-7.
LE BAS DE BAINVILLE (4347/40/16 NT) 0997310	Possible 14 FlaK tower u in hedge.	400/157 25 May 44. 4001-2.
RYEUX (4347/37/16 S?) 799314 800814 801813  805308 837808 836808 836307	4 hy u/c. 2 lt. Probable SL position u/c. 3 lt. 5 hy unemplaced. 2 lt unemplaced. Probable SL un- emplaced.	30/4046 31 May 44. 5052-3.  5052-3. 5059-60.
DIGARD (4347/31/2 S?) 10942112	3 lt now seen to be dummy position for neighbouring 6-gun hy.	1066/518 27 May 44. 3209.
OCTEVILLE (4347/31/22 S?) 12202150	1 lt.	1066/517 27 May 44. 4156.

/125 PLACES ...

TOP SECRET  
BIGOT

0 2 0 9



TOP SECRET  
BIGOT

LES FRATRES (4347/31/16 NE) 114150 114148	4 lt w/a. 3 lt w/a.	106/455 22 May 44. 4107-5.
LESSEAT (4347/31/16 NE) 133703 131723	Possible beach- light. Possible beach- light.	107/000 22 May 44. 3095-6 3098-9.
ST CHRISTOPHER DU FOC (4347/26/20 NE & NE) 063128 063146 067148	6 ht new 1 u. 5 ht occupied. 5 ht, dummy position.	1060/006 26 May 44. 4039.
VIEUX CHIRCH (4347/37/16 NE) 901734	2 AA/AB position (1 u) protecting probable emplace- ment for S.P. gun.	400/192 30 May 44.
REQUEVILLE (4347/37/16 NE) 073765	3 lt and SL.	400/192 2 June 44. 4119-20.
ST CROIX GRAND TOWER (4347/37/16 NE) 071754 077751	3 lt unemplaced. 3 lt (? 20mm) and possible SL.	400/192 2 June 44. 4116-7.
COULBES (4347/37/16 NE) 031762	... E.G.	400/192 2 June 44. 4110-9.
GREENHAM (4347/31/18 SW & 31/18 NE) A report dated 26 January 44 gives the following Flak positions at GREENHAM: 397042 401043 345042 400042	3 lt (20mm) and SL. 1 lt (20mm) 3 lt (20mm) and SL. 1st railway Flak magazines stand here at night.	
Comment: The first two positions cannot be seen on good recent air- cover. The third position is confirmed: the calibre given by source is probably accurate. The fourth item of inform- ation is likely.		
POINT D'ARE (4347/31/18 NE) 275933 277931	3 lt in rough earthen emplace- ments. 2 lt in rough earthen emplace- ments.	106G/455 22 May 44. 4110.

TOP SECRET  
BIGOT

/R.H.S. ...

0 2 1 0

TOP SECRET  
BIGOT

-4-

LATEIX (4347/57/18 SW)		
357300	5 by now 6 by	400/192
	(See above)	2 June 44.
336303	2 lt now probably	3042.
	3 lt (See above)	
832325	3 lt in field	3038-9.
	emplacements.	
799014	4 by, 2 u.	4013-4.
	(See above)	
843017	3 field emplace-	4069-70.
	ments. 7 Flak.	
796004	3 lt in field	4010-1.
	emplacements.	
812011	4 by u.	4042-3.
VIEUX PORT (4347/37/16 NW)		
842772	3 lt u.	4061.
843769	3 by.	4061.
845764	3 lt u.	4060.
846762	3 square emplace-	4059.
	ments possibly for	
	1t St Flak.	
842763	3 lt u.	4059.
HEAUMONT (4347/37/18 SE)		
852318	3 lt w/c. All	4094-5.
	occupied.	
853014	3 lt w/c. 2,	
	probably 3, oc-	
	cupied.	
851011	3 lt w/c. 1,	
	possibly 3, oc-	
	cupied.	
853009	3 lt w/c. u.	
862019	3 lt w/c. 2	4093.
	possibly occu-	
	pled.	
LIGN-SUR-SEER (4347/40/18 SW)		
065012	Probable 3 lt w/c.	400/193
		2 June 44.
		3074.
ORRAVINS (4347/51/16 NW)		
194745	Possible 3 lt.	U.S. 30/4044
		31 May 44.
		2163-4.
ST CHARLOTTE DU POC		
(4347/20/20 NS & NW)		
06631417	4 by emplace-	U.S. 30/4034
	ments just com-	27 May 44.
	pleted.	5034-5.

(N.B. This item comes from First U.S. Army's First Phase Report No. 25. The sortie has not yet been received by T.I.S.)

TOP SECRET /CLASS ...  
BIGOT

0 2 1 1

TOP SECRET  
BIGOT

-5-

CATERS (4347/40/16 IN)  
025742

3 lt w/o.

400/195.  
2 3/4 in. dia.  
319.

PERIERS-SUP-LE-DAN  
(4347/40/16 IN)  
02755

3 lt w/o.

3119.

G-2 (Intelligence) Division,  
SEAN  
3 June 1961.

TOP SECRET  
BIGOT

0 2 1 2

TOP SECRET  
BIGOTAPPENDIX 'B' TO NOTE ARGUS NO. 37  
Dated 3 June 1944.

TOP SECRET

UNDERWATER OBSTACLES1. Amendment to tracing of G.S.G.S. 4490/70

A tracing is issued showing a short stretch of hedgehogs which have been omitted from previous tracings in error. At the same time three single stakes seen on recent air cover are shown.

2. ARNEVILLE-MASTEE

Ref Map: G.S.G.S. 4490/71

Between 369105 and 371301 obstacles are seen to be wired together. A single belt of wire appears to run indiscriminately amongst the rows of tetrahedra and stakes.

Air Cover: Sortie 16/358  
of 31 May 1944

Photo No: 3046

Comment:

The map co-ordinates represent the limit of cover, and it is probable that wiring has been carried out over a wider area.

3. GRAND HAVENAU DES DUNES

Ref Map: G.S.G.S. 4490/72

Two possible single ramps are seen at 4001047 and at 4004043.

Air Cover: Sortie 16/373  
of 2 June 1944

Photo Nos: 4018-9

4. LA MADELEINE

Ref Map: G.S.G.S. 4490/74

Cover of 2 June 1944 is of very poor quality, and at some points the underwater obstacles can hardly be seen.

In addition to the extensions shown on the attached tracing, which supersedes all previous tracings, the following details are seen:-

(a) Ramps previously seen have been removed.

(b) Much track activity on the beach indicates that obstacles are in process of being erected.

(c) An unidentified object is seen at 45929550, almost in the shoreward row of obstacles. It is about 22 feet long and 8 feet wide and has little height. It is possible that it is a vehicle used to transport obstacles to their final position.

Air Cover: Sortie 16/373  
of 2 June 1944

G-2 (Intelligence) Division,  
SHAEP.  
3 June, 1944.

CONFIDENTIAL

9.5010

TOP SECRET  
BIGOT

0 2 1 3

TOP SECRET  
BIGOT

TOP SECRET

Issued with Appendix 'E' to NEPTUNE ARGUS NO. 37 dated 3 June 1944

G.S.G.S. 4470. Sheet 70. ST. JACQUES-BAY. 1:12,500

The information below is additional to that shown on the tracing issued in the NEPTUNE ARGUS NO. 33.

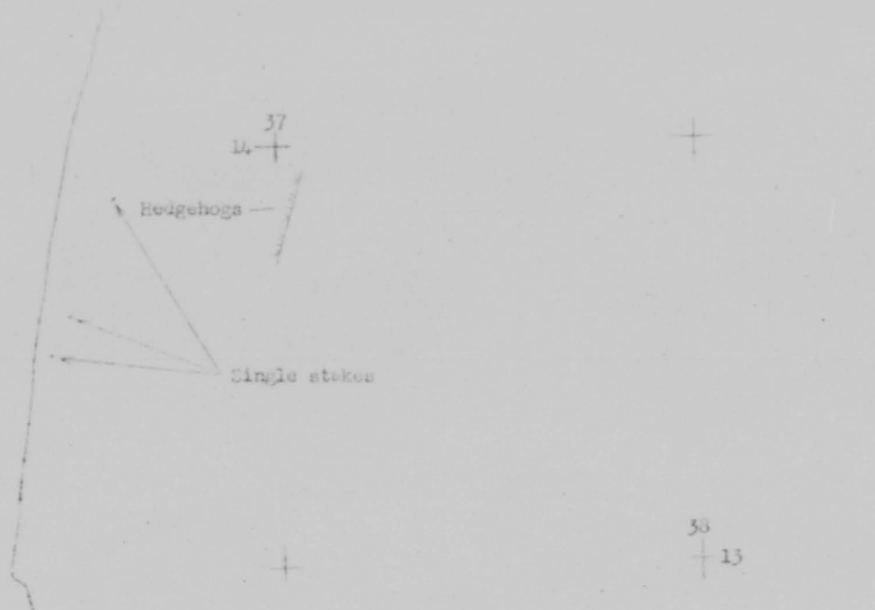

G.S.G.S. 4470. Sheet 83. VER-SUR-MER. 1:12,500 Tracing 'A' (west)

The information below is additional to that shown on the tracing issued in the NEPTUNE ARGUS NO. 31.

Sortic 400/192 of 2 June 1944. Photo Nos. 4224-5.

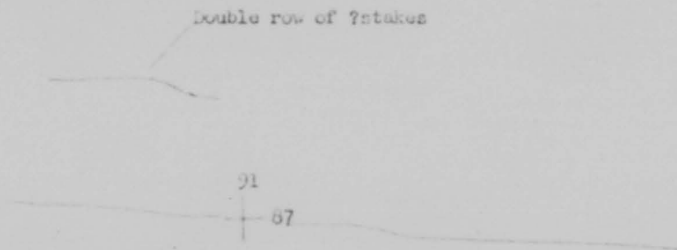

G-2 (Intelligence) Division,  
SUSP.  
3 June, 1944.

TOP SECRET  
BIGOT

0 2 1 4

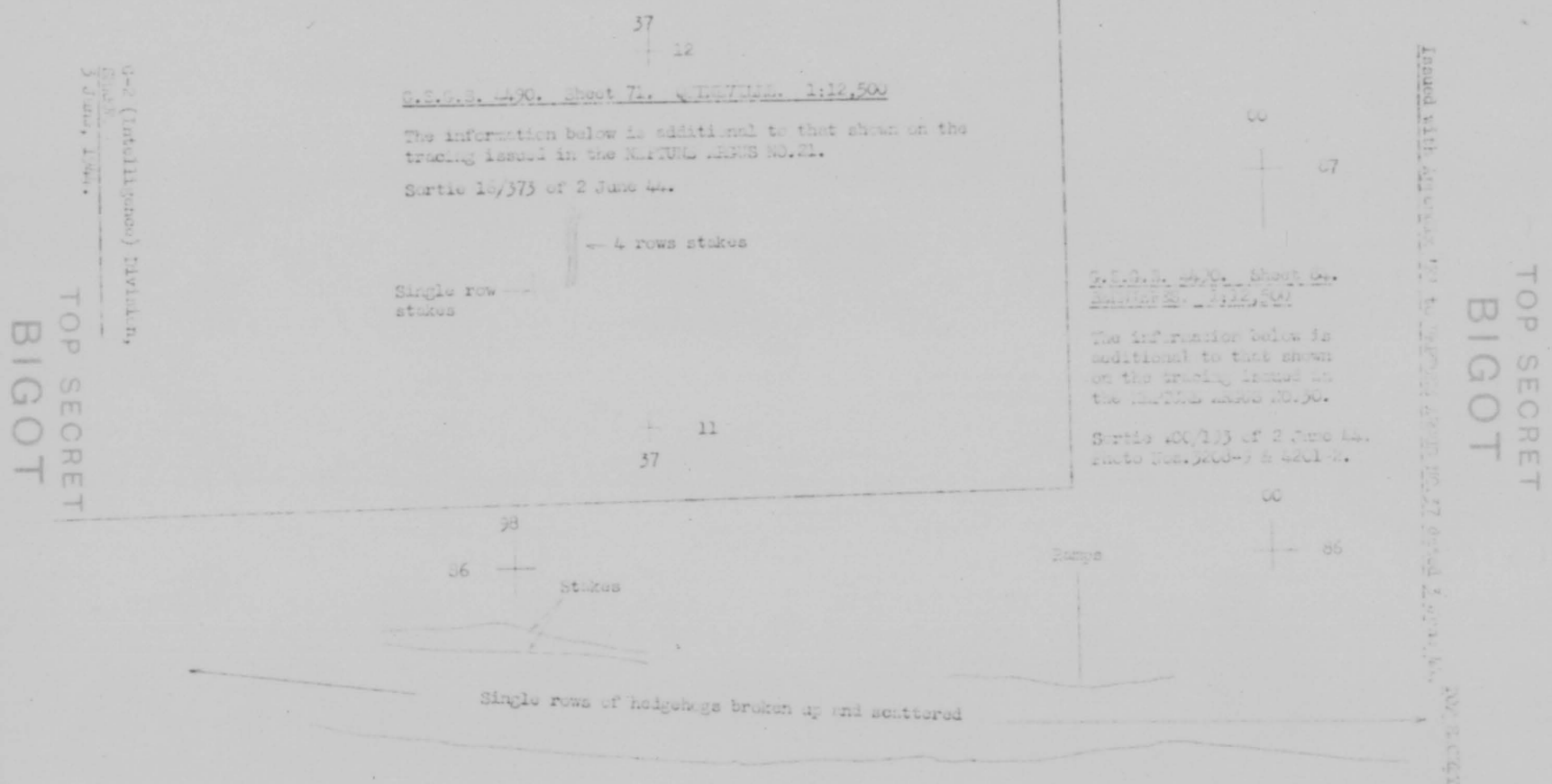

0 2 1 5



TOP SECRET

# BIGOT

TOP SECRET

Issued with Appendix 1B to Reference Manual, dated 1 June 1944.  
SECRET

This tracing supersedes all previous tracings and tracings of this map sheet.

Air Cover: Gerbie 16/373 of 2 June 1944.

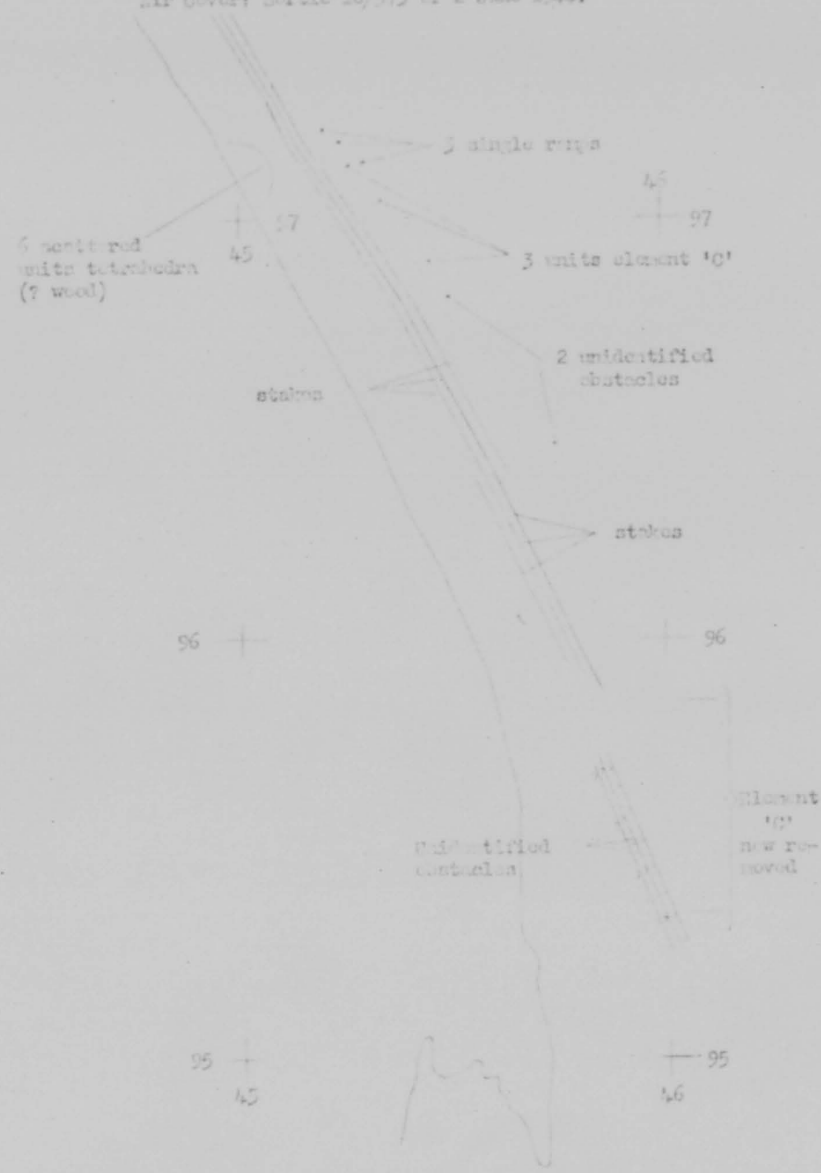

G-2 (Intelligence) Division,  
DATE  
3 June 1944.

TOP SECRET  
BIGOT

0 2 1 6

Issued with Graphic 'B' to NAVY AIRCRAFT NO. 37 dated 3 June 1944.

C. 4. 1. 7. 4. 4. 2. 0. Sheet 25. VZB-322-422. 1:12,500 tracing 'B' (East)

The information below is additional to that shown on the tracing issued in the NAVY AIRCRAFT NO. 37.

Air Cover: Sertic 400/192 of 2 June 1944. Photo Nos. 3244-F & 4297-R.

Sample Line of  
Redirection now  
Broken up & Reformed  
As a continuous belt 1-5 Deep

? Station

TOP SECRET  
BIGOT

TOP SECRET  
BIGOT

G-2 (Intelligence) Division,  
NAVY.  
3 June 1944.

0 2 1 7

TOP SECRET  
 APPENDIX 'F' TO NUTRIE AREA  
 Dated 31 May 1944

BIGOT

TOP SECRET

Minefields in the NUTRIE Area

1. LA RUE Ref. Map: 4347/31/22 SW  
 Minefield has now been extended and includes all the area between the following coordinates:  
 22002500 - 22402505 - 22202482 - 22062475  
Air Cover: Sortie 16/359 Photo Nos. 4026  
 of 31 May 1944.
  
2. MERVILLE-FRANCEVILLE Ref. Map: 4250/7F/2  
 Mines at varying spacings are seen at 158778 and round the battery at 155776.  
Air Cover: Sortie 1066/436 Photo Nos: 4061-2  
 of 29 May 1944.
  
3. RAVENOVILLE Ref. Map: 4347/34/20 SW  
 A minebelt consisting of 4-6 rows with 13 ft between rows is seen immediately behind the coast road from 409029 to 411026. The minefield is probably continuous but can be seen only intermittently between the pinpoints given.  
Air Cover: Sortie 16/328 Photo Nos: 3019-21.  
 of 29 May 1944. 4017
  
4. HOULGATE Ref. Map: 4347/40/18 SE  
 A probable minebelt extends along the top of the cliff from 25403130 to 25653138.  
Air Cover: Sortie 161/334 Photo Nos: 3163-4.  
 of 29 May 1944.
  
5. HARVEAU MAUGER Ref. Map: 4347/34/20 SW  
 Two short minebelts between double wire fences are seen enclosing the strongpoint from 41620154 - 41730143. The number of rows and the spacing can NOT be determined from the cover.  
Air Cover: Sortie US 30/4047 Photo Nos: 2047  
 of 31 May 1944. CONFIDENTIAL
  
6. DARNEVILLE Ref. Map: 4347/28/22 NW  
 A minebelt of 6 rows from 20 ft - 30 ft apart is seen from 945326 - 946325. 95210  
Air Cover: Sortie 140/207 Photo Nos: 4003.  
 of 28 May 1944.
  
7. ST PIERRE DU MONT Ref. Map: 4347/34/18 NE  
 This low oblique sortie shows that the wire surrounding the Radar station and the farm buildings at 623928 and 626928 is seen

TOP SECRET  
 BIGOT

/to bear.....

0 2 1 8

TOP SECRET  
BIGOT

- 2 -

to bear warning notices boards at frequent intervals. It is probable that the boards indicate the existence of mines around the Radar site.

Air Report: Serial 162/15      Photo Nos: 0001-13, 0028-36.  
of 31 May 1944.

8. YES SUB MTR

Ref Map: 4347/37/18 SE

Some large scale photographs show that there has been approximate destruction of the minefield at 919061 and 921864 by a number of direct hits during the bombing of the battery. About all of the craters present a perfectly normal appearance but the majority seem to be rectangular in shape rather than circular.

Air Report: Serial 140/312      Photo Nos: 4014/5  
of 30 May 1944.

9. YES SUB MTR

Ref Map: 4347/37/18 SE

Extensions to minefields as follows. In each case the minefield is 5-6 rows deep.

919061 - 921862  
919062 - 921863  
919063 - 921864  
919064 - 921865

There is a possible belt of mines, 5-6 rows deep, at 934866.

Air Report: Serial 16/314      Photo Nos: 3065-6  
of 29 May 1944.

10. YES SUB MTR

Ref Map: 4347/43/18 SE

From 4501437 to 45051430 an 8 row minefield is seen. There are 16 ft intervals between the rows and a 16 ft interval between the rows.

Air Report: Serial 16/313      Photo Nos: 3042-3  
of 29 May 1944.

11. YES SUB MTR

Ref Map: 4347/31/22 SE

A number of staggered rows of mines are seen between the two lines of wire around the perimeter of the battery at 920186.

Air Report: Serial 414/191      Photo Nos: 0006-7  
of 29 May 1944.

12. YES SUB MTR

Ref Map: 4347/31/22 SE

Rows of mines as follows:-

3962700 - 3962719      3 rows wide  
3962720 - 3962739      4 rows wide

/39622711.....

TOP SECRET  
BIGOT

0 2 1 9

TOP SECRET  
BIGOT

- 3 -

39422711 - 39452701 - 39532716 - 39552710 4 rows wide  
39532720 - 39582697 - 39422688 4 rows

Air Cover: Sortie 114/192      Photo Nos: 0004-5  
of 29 May 1944.

G-2 (Intelligence) Division,  
SHAEP.  
3 June, 1944.

TOP SECRET  
BIGOT

0 2 2 0

TOP SECRET

APPROX. 100 TO 150 TONS ASSUMPTION  
dated 3 June 1944

BIGOT

TOP SECRET

Assumption Dumps in the NEMUSE Area

1. FRANCE: DOIS DE BUNNY (LASSUS) Reference No: GNS 4040B/28 22/7067  
Date of Information: 13 March 1944.

Assumption Dump reported in DOIS DE BUNNY, centre of dump at approx. 704679.

Source: Ground.

Air Cover: None.

Amendment to: TIC/D.IV/DE/6.2

2. FRANCE: DOIS DE GROSSEVILLE (LASSUS) Reference No: GNS 4040B/28 22/6564  
Date of Information: 13 March 1944.

Assumption dump report in DOIS DE GROSSEVILLE, centre of dump at approx. 552947.

Source: Ground.

Air Cover: None.

Amendment to: TIC/D.IV/DE/6.2

3. FRANCE: LES VILAINS (MILWAUOS) Reference No: GNS 4040B/29 22/9262  
Date of information: 13 March 1944.

Assumption dump reported near LES VILAINS, centre of dump at approx. 924626.

Source: Ground.

Air Cover: None.

Amendment to: TIC/D.IV/DE/6.2

4. FRANCE: BOURG (LOIR ET CHER) Reference No: Air 5000/108 21.  
47°20'40" N.  
01°06'40" E.

Date of Information: 1 April 1944.

The G.T. is at present engaged on important work in under round quarries at BOURG, situated near the road and railway from VIERZON to TOURS.

The quarries are to be used for underground storage of ammunition and stores. The galleries have a total length of 16 km and afford adequate space for trucks to move through them. They are protected by 10-25 m. of rock or earth.

Source: Ground.

Air Cover: None.

Comment:

Previous reports of December 1943 and February, 1944 stated that the Germans were first staking the mushroom caves of the BOURG region from the standpoint of ventilation, humidity and drainage; then, later, that these caves were being fitted out, possibly as ammunition or supply dumps.

TOP SECRET

/Amendment to:

0 2 2 1



TOP SECRET  
BIGOT

- 2 -

Assignment to: WIG/O.IV/327/3.2

5. FRANCH: FOUR DE LA 3.5.114/ Reference No: 3273 4250/425/563036.  
BOIS DE LA 1.1.1.1.1.1.1. Date of Information: 10 March 1944.

Dug of hand grenades in cases, located in BOIS DE LA 1.1.1.1.1.1.1, to the left of road running from DE LA 1.1.1.1.1.1.1 BOIS to DE LA 1.1.1.1.1.1.1, at approx. 963036.

Source: Ground.Air Cover: None.Assignment to: WIG/O.IV/327/3.2

6. FRANCH: ARCADES (L.1.1.1.1) Reference No: 3273 4250/512/9631.  
Date of Information: May 1944.

A group of 19 rectangular holes is seen at 963034. These are laid in four rows, 3 of the rows having 5 holes. Two similar rows, with 5 holes to each row, are seen at 963035. Each hole is surrounded by spoil, and cover of 20.5.44 shows that the spoil thrown up since then has covered a little number of smaller holes each sited slightly on the SW side of the holes now visible. The proximity of all this to a disused 7 gun Heavy Tank Battery suggests the probability of its being an ammunition dump or petrol storage.

Photos: 16/359 of 31.5.44, photo No. 4308.  
1064/440 of 20.5.44, photo No. 3096.

Source: Air.Air Cover: Good.Assignment to: WIG/O.IV/427/3.2

G-2 (Intelligence) Division,

3 MAY 1944.

TOP SECRET  
BIGOT

0 2 2 2

TOP SECRET  
BIGOTATTACHED TO "TOP SECRET" REPORT NO. 37  
DATE 3 APR 1964

TOP SECRET

## Signals Installations: Additions to Cable Trenches

Map Sheet Place	Map Reference	Description	Location and Date
43/18 S.W. D. 4275-2	43321056 - 41871053 - 43701120	New cable trench	140/157 22 May 44 4045/47
28/22 Camp SIT. GAKIN WAGON	05 243 - 027341 - 021204	Cable trench	1066/455 22 May 44 4046
28/22 Camp and 31/22 S.W. CAMP. N	090212 - 102215	Cable trench	15/204 22 May 44 3079
37/18 S.W. D. 4275-2	74475 - 70450	Second cable trench constructed	140/157 22 May 44 3177/8 4101/2
37/18 S.W. VIA S.W. S.W.	91743 - 90034	New cable trench connecting VIA S.W. to S.W. S.W. with main lateral cable	10 34/451 24 May 44 50119
37/18 S.W. D. 4275-2	38429	A new cable trench runs north from the previously reported trench as far as 05 24 where cover ends	16/249 23 May 44 310/11
40/18 S.W. D. 4275-2	2990133 - 2970172	Cable trench runs between points given connecting cable trench at 29706172	140/157 22 May 44 3070
40/16 S.W. D. 4275-2	252779 - 255700	Extension of cable trench	16/259 27 May 44 312/8
34/18 S.W. D. 4275-2	504315 - 577907	Cable trench under construction	1066/516 26 May 44 3130/1
37/18 S.W. D. 4275-2	90543 - 05684	New cable trench linking up cable running south from 05 24 with main lateral cable	40/151 24 May 44 5157
43/18 S.W. D. 4275-2	30743 - 300421	New cable trench	140/157 22 May 44 3067 - 68

CONFIDENTIAL  
 PREPARED BY: [illegible]  
 DATE: 1 APR 1964  
 FORM: [illegible]

95pic  
 TOP SECRET  
 BIGOT

/1A P. 1111.....

0 2 2 3

TOP SECRET  
BIGOT  
- 2 -

Day/Sheet Place	Map Reference	Remarks	Grid and Date
31/22 SE LA FORTUNE	36223 - 36200	Cable trench to LA FORTUNE battery	1060/431 18 May 44. 4331/3
31/18 SE LA FORTUNE BARR	139020 - 150005	Few cable trench probably connecting up to 125030	10/222 15 May 44. 4153/7
31/20 SE LA BELLEVILLE	365038 - 361044 - 365047	Few cable trench	16/277 18 May 44. 4026
29/22 Comp. LAUTWIL	091253 - 090248	Cable trench extended	1060/518 27 May 44. 4252
31/20 SE LA BISSON	363007 - 364005	Overhead cable line	1060/455 22 May 44. 3125
31/16 SW LAUREAT	106775 - 214735	Cable will probably connect to junction box at 101775	103 35/434 27 May 44. 5007
30/16 SW ST CATHARINE	466718	Chateau de la MARE DE CAWLEY is occupied by troops. Cable trench runs from Chateau to farmhouse on road at 470725. Vertical tower [1/11] at chateau	1060/500 10 May 44. 4161/3
37/18 SE ST-JACQUES SUR MER	353024	Few cable trench branches off from main cable at this point and runs north to group of buildings at 351132.	400/167 30 May 44. 3072/4
	021037 - 021032	Probable cable trench	400/167 30 May 44. 3072/4
31/20 SE OUEVILLE	354044 - 353059	Overhead cable lines	10/245 22 May 44. 4022
	354057 - 353054	" " "	
	356057 - 353056	" " "	
	356037 - 362035	" " "	

/ WASHINGTON.....

TOP SECRET  
BIGOT

0 2 2 4

TOP SECRET  
BIGOT

- 3 -

Map Sheet Place	Map Reference	Remarks	Sortie and Date
21/22 Loop. LAQUINTIE	066259 - 067253	Cable trench	16/260 24 May 44 3161
34/18 1E VILLIERS SUR MER	064506 - 065003	Cable trench now complete	18/313 28 May 44 4024/5

G-2 (Intelligence) Division,  
STATE.

TOP SECRET  
BIGOT

0 2 2 5

**SECRET**

SUPREME HEADQUARTERS  
ALLIED EXPEDITIONARY FORCE  
G-3 (Ops) Division

Map and Survey Section

MAP PROGRESS REPORT NO. 9  
3 June 1944

Item	Notes.
1.	Notes.
2.*	Summary of Maps Available in Western Europe for Operational Use.
3.*	Progress Chart 1:1,000,000 Topographic Maps.
4.*	Progress Chart 1:500,000 Air Maps.
5.*	Progress Chart 1:250,000 Air Maps.
6.*	Progress Chart Road Maps.
7.	Progress Chart 1:250,000 Army/Air Maps.
8.	Progress Chart 1:100,000 Topographic Maps.
9.	Progress Chart 1:50,000 Topographic Maps.
10.*	Progress Chart 1:50,000 Topographic Maps. (Provisional Edition)
11.	Progress Chart 1:25,000 Topographic Maps N. France, Belgium and Holland.
12.**	Progress Chart 1:25,000 Topographic Maps S. France.
13.	Progress Chart 1:25,000 Photo Maps.
14.*	Progress Chart Thru Route Town Plan Booklets.
15.**	Progress Chart Large Scale Topographic Maps and Town Plans.

\*Not included in this report. See Report No. 5.  
\*\*Not included in this report. See Report No. 8.

NOTES

1. Progress since last report and status as of 31 May 1944 shown on attached charts.

2. Map Progress Reports.

a. Hitherto these Map Progress Reports have shown sheets as "Printed" as soon as it was known that they were off the printing press. There is frequently a definite lag between the date of completion of printing and the date on which the printed sheets reach map depots and become available for issue to troops. Effective with publication of Map Progress Report No 10, it is planned to indicate progress in terms of the following status:

(1) In Progress - denoting sheets in varying states of layout, compilation, and drafting, but not yet placed on printing plates. Copies of these sheets will not be available.

(2) Reproduction Stage - denoting sheets which have been placed on printing plates (including proofs), those on the presses, and those which may have been printed but are not yet available in operational depots in the UK or on the Continent. Urgent requirements for small numbers of these sheets can sometimes be met by special arrangements.

(3) In Map Depots - denoting sheets which are available in operational depots in the UK or (later) on the Continent. Redlines of these sheets (except in the case of GSGS 4238 and scales of 1:1M and smaller) also can be expected to be available for field reproduction.

b. In order to effect as smooth a transition as possible to this new basis of indicating progress, an additional sheet has been shown in this report as "Printed" unless it is known also that stocks have reached the depots. Accordingly a number of sheets shown at "Proof Stage" may in fact have been printed but not yet placed in operational depots in the UK.

Distribution/Overleaf

**SECRET**9510  
1722

0 2 2 6

DISTRIBUTION:

Distribution List "D" SNAEF	20 copies
TIS, SNAEF (Maj DuPa)	125 "
D Svy, 21 Army Group, Rear (Col H.A.L. Shewell)	10 "
Engineer Sect. FUSAG (Lt Col Milne)	50 "
Chief, Intelligence Branch OCE, ETOUSA (Col Milwit)	10 "
DAD Svy, ARAF (Maj Godfrey)	27 "
Svy 2, D Military Survey, The War Office (Brig Notine)	1 "
Assistant Hydrographer, Admiralty Whitehall (Capt Hay)	2 "
Svy 3C, The War Office (Capt Wimbush) Rm 106	1 "
AD Svy, GHQ, Home Forces (Lt Col H.A. Bazley)	7 "
Intelligence Branch, Combined Operations HQ (Maj G.G. Rice)	1 "
Secretary, Joint Staff (Col Capel-Dunne)	2 "
Chief of Staff, Cdn Mil HQ (Attn RGS, Brig H.M.S. Penhale)	1 "
Engineer Sect, HQ Forward Echelon CL, ETOUSA (Capt G. L. Noah)	9 "
Force Intelligence Officer, CTF, 15 Grosvenor Sq, W.1. (Capt Ragonnet)	3 "







EUROPE  
INDEX TO 1:250,000 MAP SERIES

PROGRESS CHART

AS OF 31 May 1944

LEGEND

-  Limits of Area scheduled for Production
-  In Progress
-  Proof Stage
-  Printed
-  Progress since last report

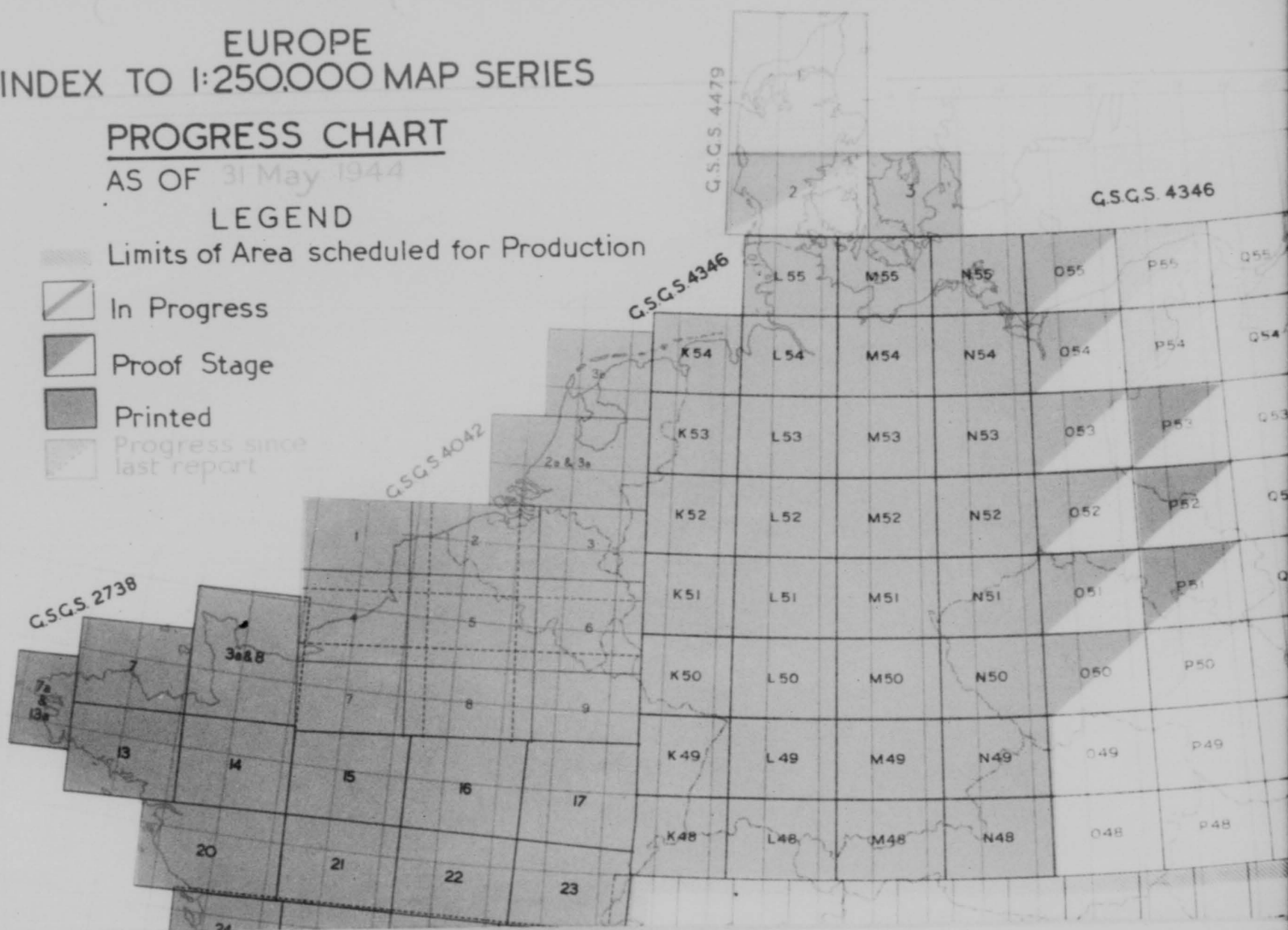

0 2 2 8

SECRET

ERIES

Production







0 2 2 9

EUROPE  
INDEX TO 1:250,000 MAP SERIES

PROGRESS CHART

AS OF 31 May 1944

LEGEND

-  Limits of Area scheduled for Production
-  In Progress
-  Proof Stage
-  Printed
-  Progress since last report

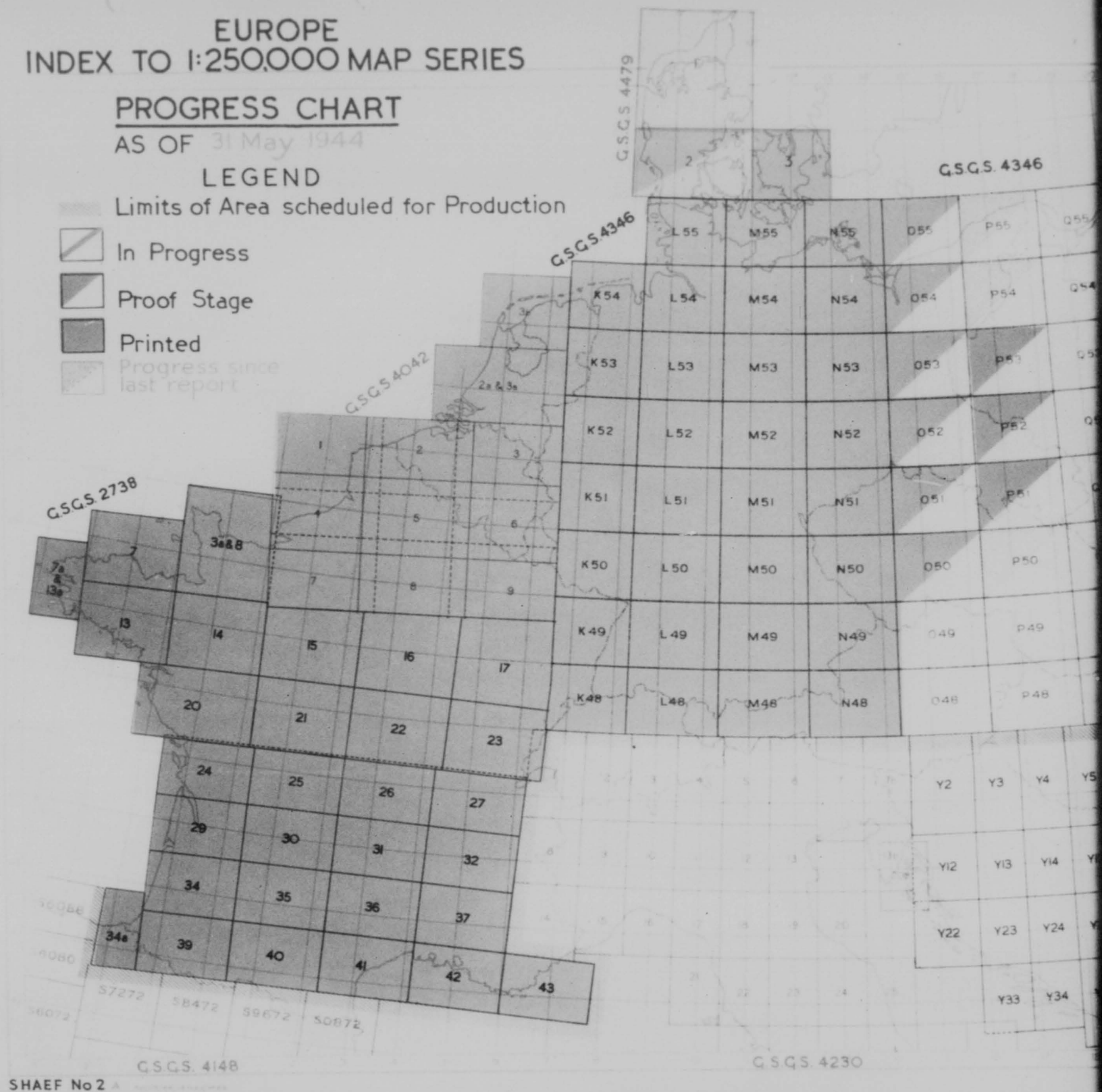

0 2 3 0

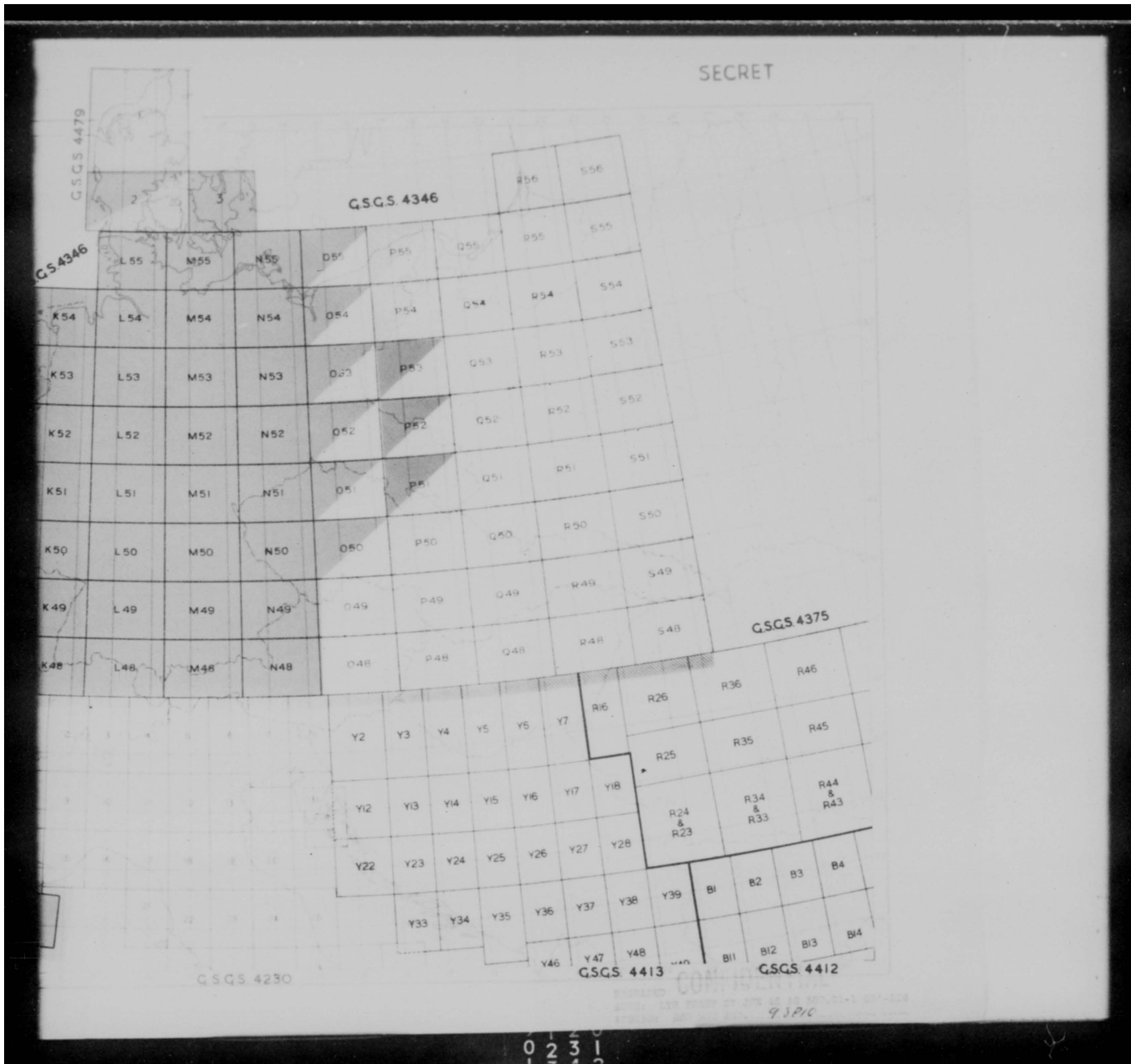







EUROPE  
INDEX TO 1:100,000 MAP SERIES

PROGRESS CHART

AS OF 31 May 1944

LEGEND

-  Limits of Area scheduled for Production
-  In Progress
-  Proof Stage
-  Printed
-  Progress since last report

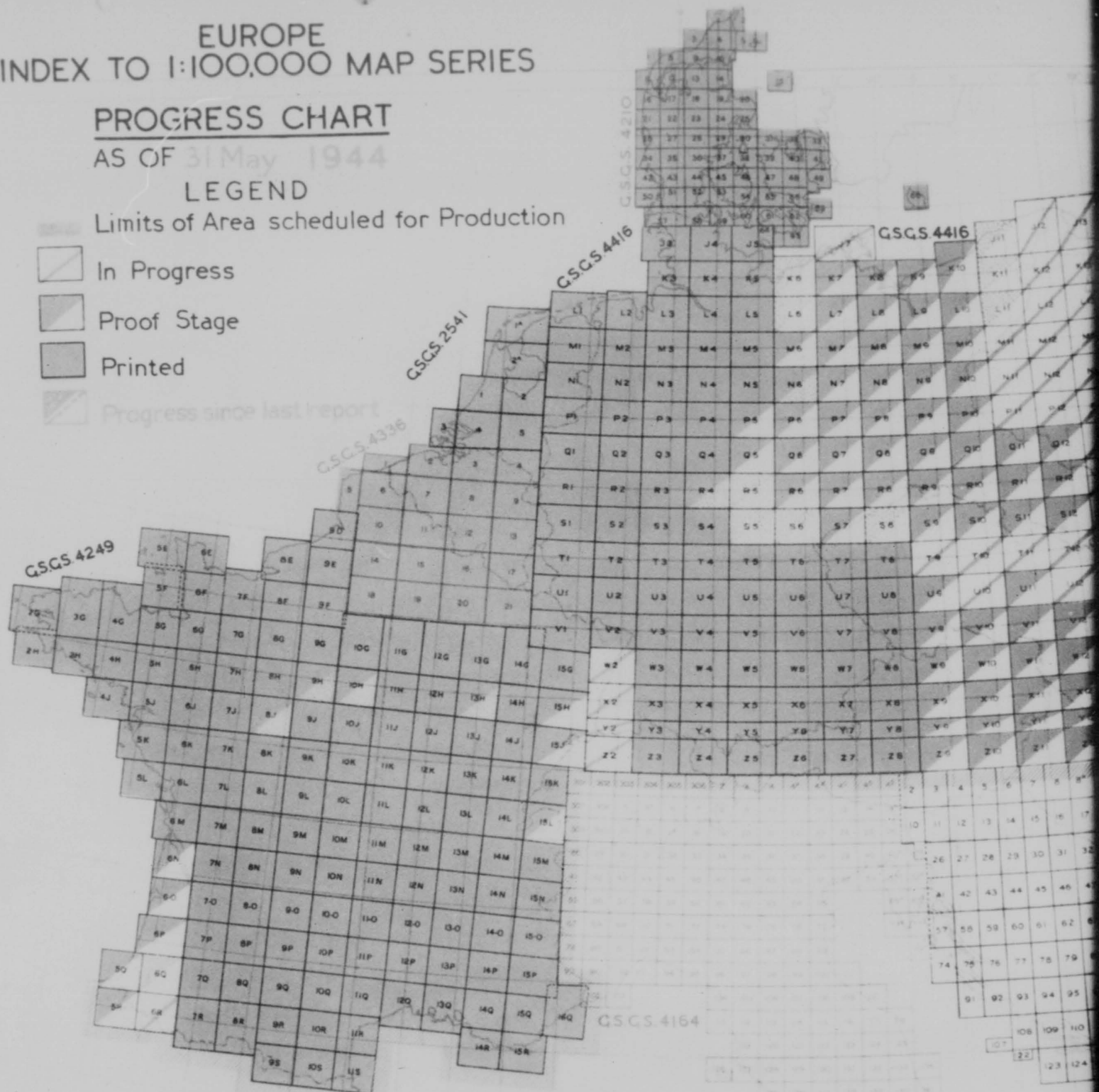

SHAEF No 4

0 2 3 2

ES

SECRET

uction

The grid consists of several overlapping sections of alphanumeric characters. The main section is a large grid of letters A-Z and numbers 0-9. Other sections include:

- GSGS 4210**: A small grid of numbers 1-30.
- GSGS 4416**: A grid of letters K3-K9, L1-L9, M1-M9, N1-N9, O1-O9, P1-P9, Q1-Q9, R1-R9, S1-S9, T1-T9, U1-U9, V1-V9, W1-W9, X1-X9, Y1-Y9, Z1-Z9.
- GSGS 4396**: A grid of numbers 1-38.
- GSGS 4164**: A grid of numbers 1-14.

CONFIDENTIAL  
23710

0 2 3 3







SECRET

FRANCE BELGIUM & HOLLAND  
INDEX TO 1:50,000 MAP SERIES

PROGRESS CHART

AS OF 31 May 1944

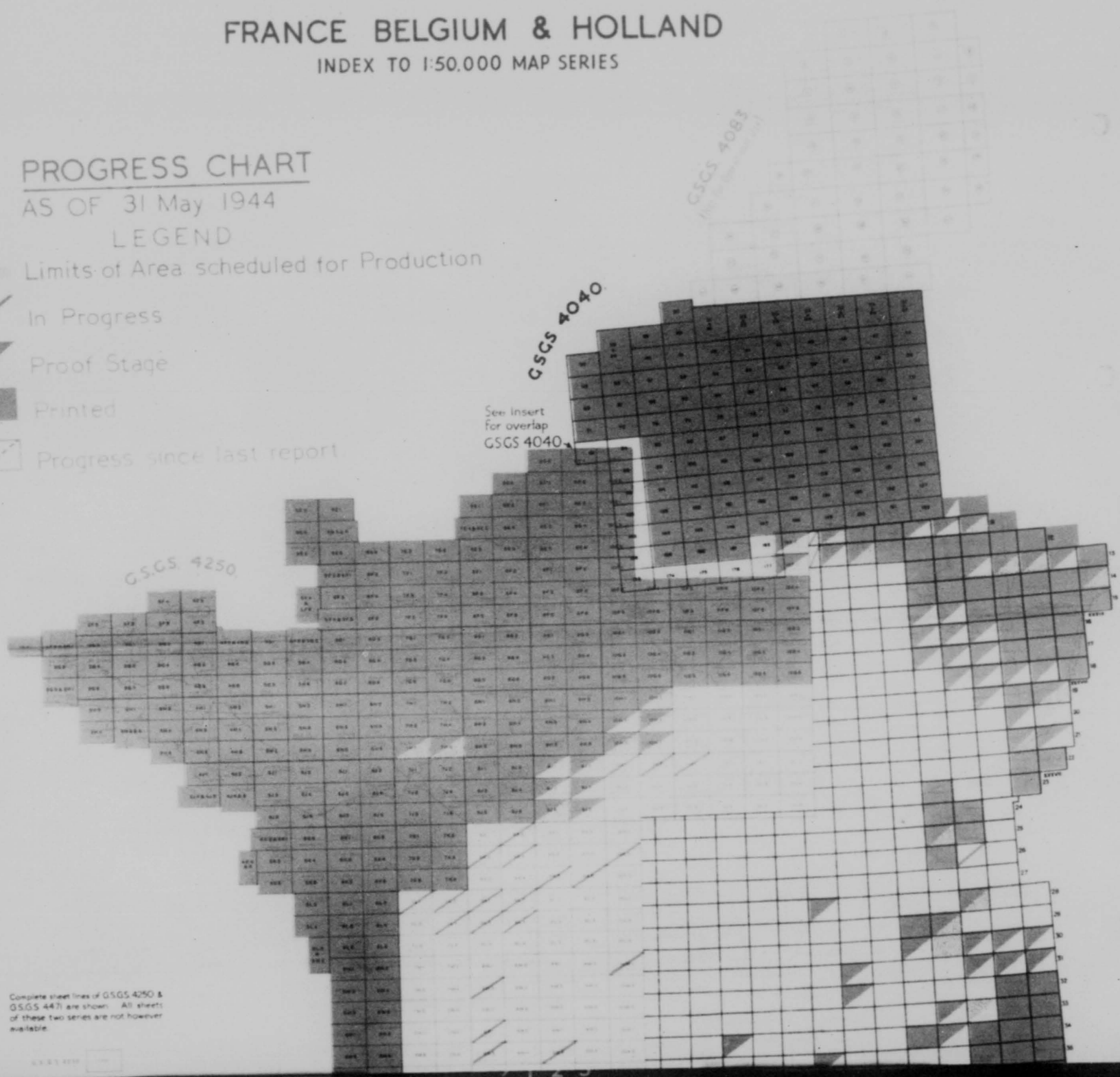

LEGEND

-  Limits of Area scheduled for Production
-  In Progress
-  Proof Stage
-  Printed
-  Progress since last report



Complete sheet lines of G.S.G.S. 4250 & G.S.G.S. 4471 are shown. All sheets of these two series are not however available.



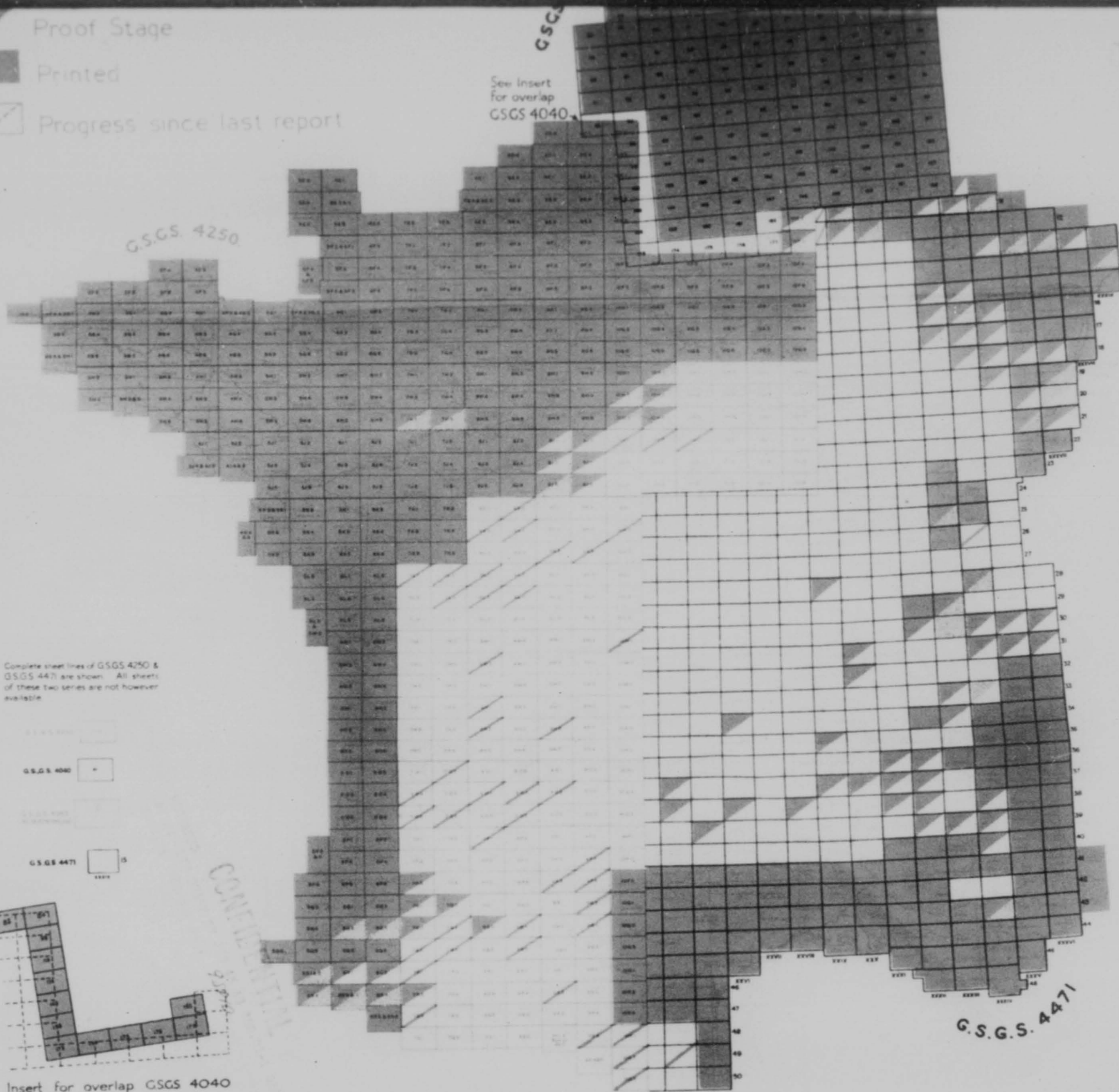

0 2 3 4  
1 2 3 4

-  Proof Stage
-  Printed
-  Progress since last report

See insert  
for overlap  
GSGS 4040



Complete sheet lines of GSGS 4250 & GSGS 4471 are shown. All sheets of these two series are not however available.

-  G.S.G.S. 4250
-  G.S.G.S. 4040
-  G.S.G.S. 4471
-  G.S.G.S. 4471



Insert for overlap GSGS 4040

SHEET No. EA 100/3, 44 (3MRL) 408





0 2 3 5

**PROGRESS CHART**  
AS OF 31 MAY 1944

**FRANCE, BELGIUM & HOLLAND**  
Index to 1:25,000 series

**LEGEND**

Limits of Area scheduled for Production

-  In Progress
-  Proof Stage
-  Printed
-  Progress since last report

SECRET

INSERT FOR OVERLAP  
G.S.G.S. 4347



G.S.G.S. 4414

G.S.G.S. 4427

G.S.G.S. 4041

G.S.G.S. 4347

G.S.G.S. 4411

XX XX	The sheets are referred to by the number followed by the letter W. No. of the W. No.
XX XX	The sheets are referred to by the number followed by the letter W. No. of the W. No.
XX XX	The sheets are referred to by the number followed by the letter W. No. of the W. No.
XX XX	The sheets are referred to by the number followed by the letter W. No. of the W. No.

G.S.G.S. 4041

G.S.G.S. 4347

CONFIDENTIAL

SHAEP No 10 A

G.S.G.S. 4365

0 2 3 6

PART

# FRANCE, BELGIUM & HOLLAND

Index to 1:25,000 series

SECRET

uled

port

G.S.G.S. 4414

G.S.G.S. 4427

G.S.G.S. 4041

G.S.G.S. 4347

G.S.G.S. 4411

The sheets are identified by the number followed by the letters A, B, C, D, E, F, G, H, I, J, K, L, M, N, O, P, Q, R, S, T, U, V, W, X, Y, Z, AA, AB, AC, AD, AE, AF, AG, AH, AI, AJ, AK, AL, AM, AN, AO, AP, AQ, AR, AS, AT, AU, AV, AW, AX, AY, AZ, BA, BB, BC, BD, BE, BF, BG, BH, BI, BJ, BK, BL, BM, BN, BO, BP, BQ, BR, BS, BT, BU, BV, BW, BX, BY, BZ, CA, CB, CC, CD, CE, CF, CG, CH, CI, CJ, CK, CL, CM, CN, CO, CP, CQ, CR, CS, CT, CU, CV, CW, CX, CY, CZ, DA, DB, DC, DD, DE, DF, DG, DH, DI, DJ, DK, DL, DM, DN, DO, DP, DQ, DR, DS, DT, DU, DV, DW, DX, DY, DZ, EA, EB, EC, ED, EE, EF, EG, EH, EI, EJ, EK, EL, EM, EN, EO, EP, EQ, ER, ES, ET, EU, EV, EW, EX, EY, EZ, FA, FB, FC, FD, FE, FF, FG, FH, FI, FJ, FK, FL, FM, FN, FO, FP, FQ, FR, FS, FT, FU, FV, FW, FX, FY, FZ, GA, GB, GC, GD, GE, GF, GG, GH, GI, GJ, GK, GL, GM, GN, GO, GP, GQ, GR, GS, GT, GU, GV, GW, GX, GY, GZ, HA, HB, HC, HD, HE, HF, HG, HH, HI, HJ, HK, HL, HM, HN, HO, HP, HQ, HR, HS, HT, HU, HV, HW, HX, HY, HZ, IA, IB, IC, ID, IE, IF, IG, IH, II, IJ, IK, IL, IM, IN, IO, IP, IQ, IR, IS, IT, IU, IV, IW, IX, IY, IZ, JA, JB, JC, JD, JE, JF, JG, JH, JI, JJ, JK, JL, JM, JN, JO, JP, JQ, JR, JS, JT, JU, JV, JW, JX, JY, JZ, KA, KB, KC, KD, KE, KF, KG, KH, KI, KJ, KK, KL, KM, KN, KO, KP, KQ, KR, KS, KT, KU, KV, KW, KX, KY, KZ, LA, LB, LC, LD, LE, LF, LG, LH, LI, LJ, LK, LL, LM, LN, LO, LP, LQ, LR, LS, LT, LU, LV, LW, LX, LY, LZ, MA, MB, MC, MD, ME, MF, MG, MH, MI, MJ, MK, ML, MM, MN, MO, MP, MQ, MR, MS, MT, MU, MV, MW, MX, MY, MZ, NA, NB, NC, ND, NE, NF, NG, NH, NI, NJ, NK, NL, NM, NN, NO, NP, NQ, NR, NS, NT, NU, NV, NW, NX, NY, NZ, OA, OB, OC, OD, OE, OF, OG, OH, OI, OJ, OK, OL, OM, ON, OO, OP, OQ, OR, OS, OT, OU, OV, OW, OX, OY, OZ, PA, PB, PC, PD, PE, PF, PG, PH, PI, PJ, PK, PL, PM, PN, PO, PP, PQ, PR, PS, PT, PU, PV, PW, PX, PY, PZ, QA, QB, QC, QD, QE, QF, QG, QH, QI, QJ, QK, QL, QM, QN, QO, QP, QQ, QR, QS, QT, QU, QV, QW, QX, QY, QZ, RA, RB, RC, RD, RE, RF, RG, RH, RI, RJ, RK, RL, RM, RN, RO, RP, RQ, RR, RS, RT, RU, RV, RW, RX, RY, RZ, SA, SB, SC, SD, SE, SF, SG, SH, SI, SJ, SK, SL, SM, SN, SO, SP, SQ, SR, SS, ST, SU, SV, SW, SX, SY, SZ, TA, TB, TC, TD, TE, TF, TG, TH, TI, TJ, TK, TL, TM, TN, TO, TP, TQ, TR, TS, TT, TU, TV, TW, TX, TY, TZ, UA, UB, UC, UD, UE, UF, UG, UH, UI, UJ, UK, UL, UM, UN, UO, UP, UQ, UR, US, UT, UY, UZ, VA, VB, VC, VD, VE, VF, VG, VH, VI, VJ, VK, VL, VM, VN, VO, VP, VQ, VR, VS, VT, VU, VV, VW, VX, VY, VZ, WA, WB, WC, WD, WE, WF, WG, WH, WI, WJ, WK, WL, WM, WN, WO, WP, WQ, WR, WS, WT, WU, WV, WW, WX, WY, WZ, XA, XB, XC, XD, XE, XF, XG, XH, XI, XJ, XK, XL, XM, XN, XO, XP, XQ, XR, XS, XT, XU, XV, XW, XX, XY, XZ, YA, YB, YC, YD, YE, YF, YG, YH, YI, YJ, YK, YL, YM, YN, YO, YP, YQ, YR, YS, YT, YU, YV, YW, YX, YY, YZ, ZA, ZB, ZC, ZD, ZE, ZF, ZG, ZH, ZI, ZJ, ZK, ZL, ZM, ZN, ZO, ZP, ZQ, ZR, ZS, ZT, ZU, ZV, ZW, ZX, ZY, ZZ.

G.S.G.S. 4041

G.S.G.S. 4427

G.S.G.S. 4414

S. 4347

G.S.G.S. 4411

0 2 3 7



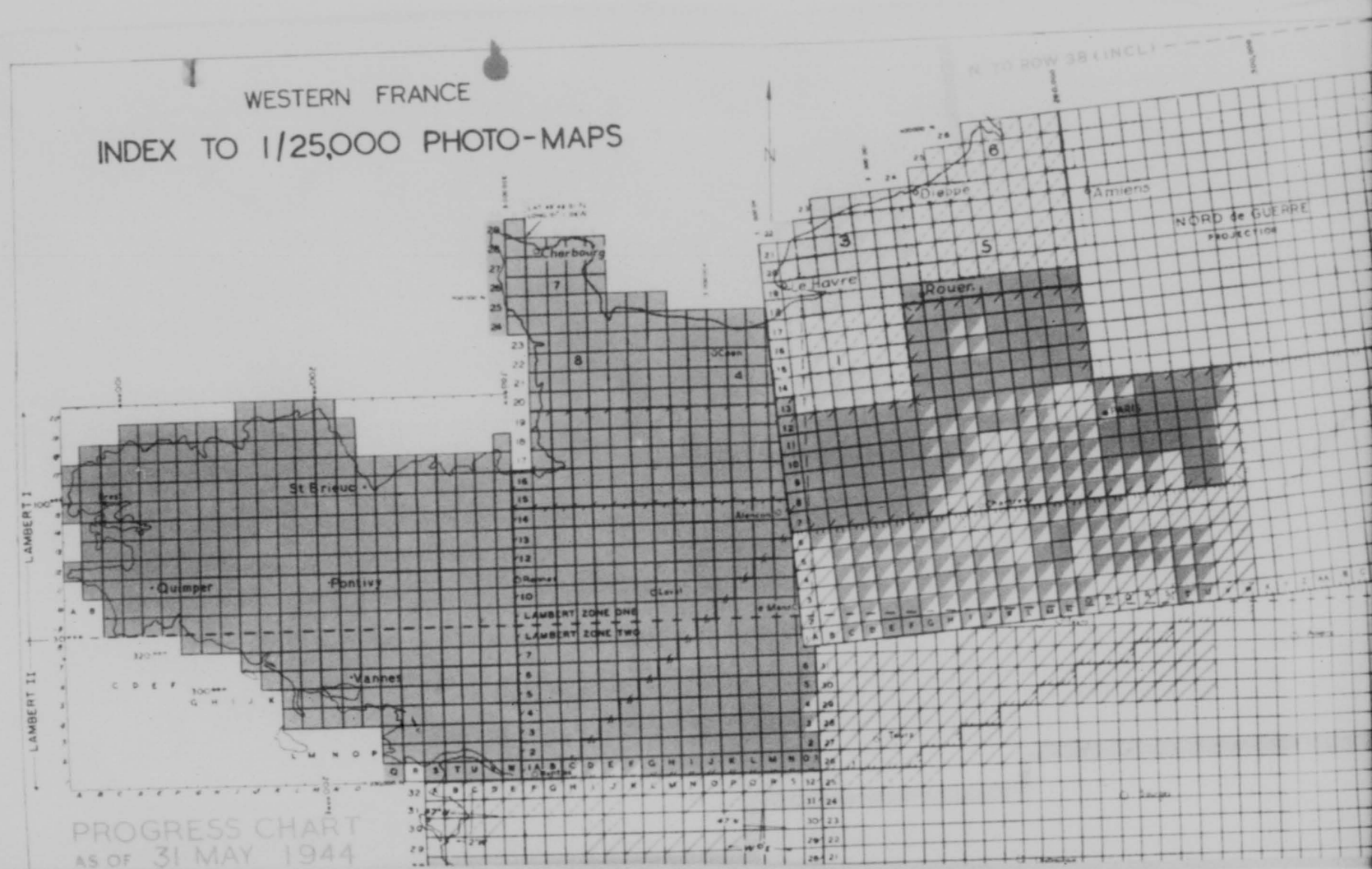

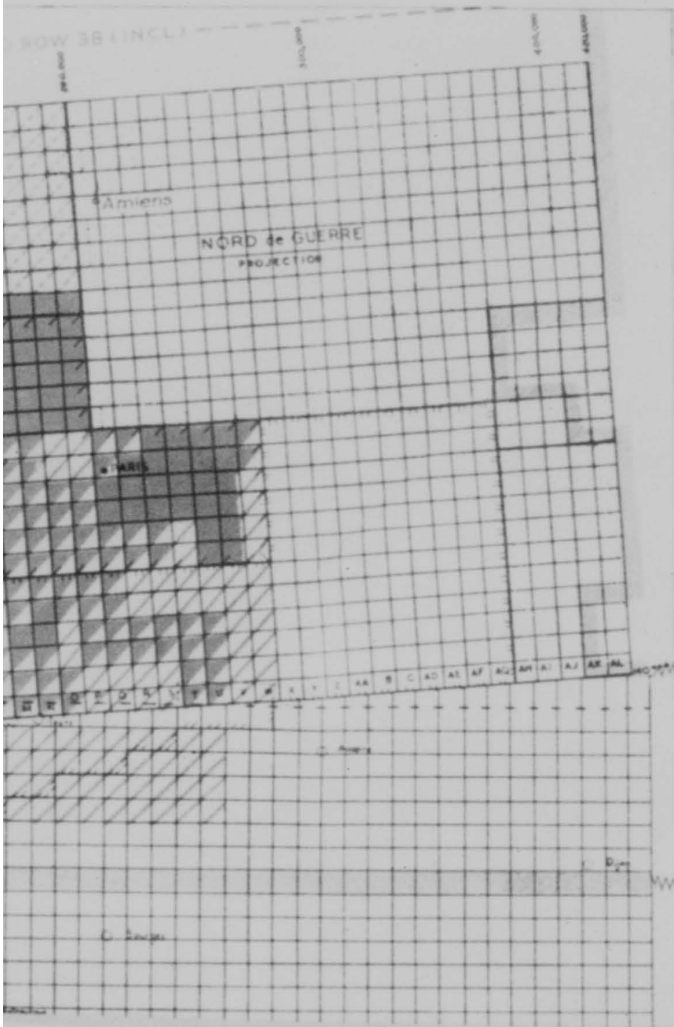

SECRET

1  
2  
3  
9



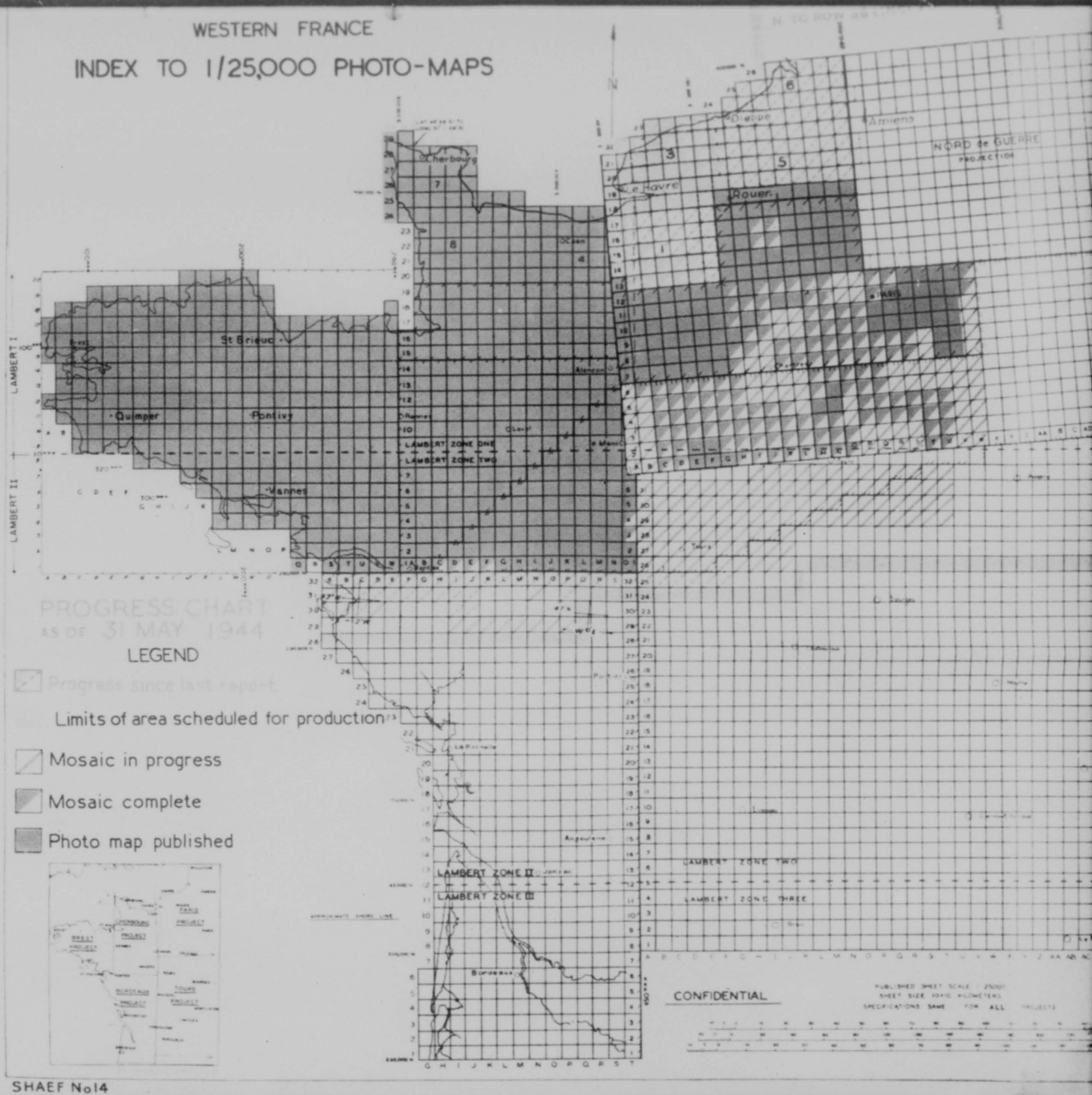

0 2 4 0



BIGOT

TIS/00/152/1SUPREME HEADQUARTERS,  
ALLIED EXPEDITIONARY FORCE,  
G-2 (INTELLIGENCE) DIVISION.TOP SECRETCopy 1 of 14 June 1944

NEPTUNE ARBUS NO: 38

With this Report:

- Appendix 'A' - Artillery
- Appendix 'B' - Flak
- Appendix 'C' - Minor Defenses
- Appendix 'D' - Obstacles
- Appendix 'E' - Minefields
- Appendix 'I' - Signals Installations

1. Underwater obstacles: Rafts

8 rafts can be seen near SP. ANBEN-SUR-NEER on the latest cover. (See tracing of CGCS 4490 Sheet 34, issued with Appendix 'E' of this report).

An interesting development noted is the fastening of two, and in some cases three, spars across the rafts, presumably to improve stability.

These spars are between 8 feet and 12 feet in length. In six cases they are laid across the top of the raft; in the other two cases they are fastened underneath the raft. (See sketch below).

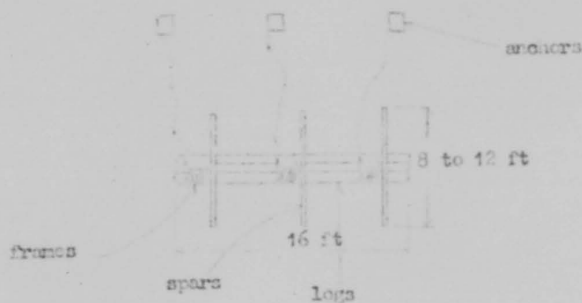

Air Cover: Sortie 16/385  
of 3 June 44

Photo Nos. 3001-2 &  
4001-2

CONFIDENTIAL

CLASSIFIED BY: [illegible]  
DATE: 10/15/84 BY: [illegible]  
FORMER: [illegible] 95P10 /2.

TOP SECRET  
BIGOT

#1788

0 2 4 2

- 2 -

2. Second bombing attack on fuel depot at DOUVEGNY on 2 June 1944-

Reference Map: 4250/71/1/788030

This target had been attacked on 28 May 1944 (NEPTUNE ARGUS NO. 35, paragraph 1). After the attack on 2 June 1944, cover shows that 6 oil tanks which were originally camouflaged are probably badly damaged although it is NOT possible to see what extent as the remains of the camouflage roof is still on top of them. Three large tanks and two smaller ones appear undamaged except that the camouflage on the top has been destroyed. Most of the factory buildings next to the fuel store appear to be gutted. Owing to the smoke it is NOT possible to give a full estimate of the damage caused.

Air Cover: Sortie U.S. 12/125 of Route No: 5001/2  
2 June 1944.

3. FLAK.

Since NEPTUNE ARGUS Report No. 37, there is further information of the strengthening of Flak defences in the BAFOUA-area. South and West of the town a number of light Flak positions have been prepared and some were already occupied on June 2, 1944, and about a mile East of the town two more heavy Flak emplacements have been prepared.

Reinforcement of Flak is now equally evident in the area South of OUISTREHAM. A new 4-gun heavy battery is seen at HERMANVILLE-SUR-MER and a heavy position North of CAEN which had been thought abandoned has now been re-occupied (See Appendix B.)

4. Underwater Obstacles.

Photographic cover during the past week (up to 3 June 1944) has shown few additions or alterations to underwater obstacles in the NEPTUNE Area. Laying of obstacles appears to be nearing completion; most work probably remains to be done in the LA MERLAIN area in the East COAST, following the recent removal of Elements 'C' from that area. Most of the new obstacles on all beaches are timber rafts.

The number of concrete boxes seen on NEPTUNE beaches remains very small. A possible group of these devices is reported from photographs of the beach between GRANDCAMP and ISIGNY. If this is correct, it is the first case of boxes on a beach far removed from any inhabited locality.

In the LUC-SUR-MER area a number of rafts are being constructed on the beach.

An interesting feature on very large-scale photographs of 3 June is what is probably a dump of 47 Tellermines at a beach exit at LA GROSSE near OUISTREHAM. Further west near LION-SUR-MER, 9 more Tellermines can be seen at a beach exit. Mining of underwater obstacles is evidently still in progress. A further example of cable between obstacles has been noted at LE HOMME-SUR-MER. East of the ORNE: also a possible short stretch at ST. AUBIN-SUR-MER.

*W. H. Hutton* Capt.  
for Major-General,  
A.C. of S,  
G-2.

TOP SECRET  
BIGOT

0 2 4 3

TOP SECRET  
BIGOTAPPENDIX A TO REPORT AREA NO. 38  
Dated 4 June 1944.

TOP SECRET

## APPENDIX A TO REPORT AREA NO. 38

I Reb Damage Reports

- 1.
- OSAGE
- Ref. Map: G.S.G.S. 4250/881/565452

No additional damage resulted from bombing of 1 June. No repairs have been made on the site since the attack of 26 May 1944.

Air Cover: Sortie 15/101 Photo nos. 5015-4  
of 2 June 1944.

- 2.
- LA COUVRE
- Ref. Map: G.S.G.S. 4250/781/815/464314

This three gun 170 mm. battery was attacked on 1 June, with the following results:

No. 1 casemate: No damage. Casemate appears complete apart from the superstructure.

No. 2 casemate: Three near misses, one of which may have caused some damage. The casemate appears complete.

No. 3 casemate: No damage. Casemate appears complete, and probably occupied.

Two open emplacements are undamaged, and occupied.

Air Cover: Sortie 15/104 Photo nos. 5003-4  
of 2 June 1944.

- 3.
- LANGUES
- Ref. Map: G.S.G.S. 4250/735/797071

No noteworthy additional damage resulted from bombing of 2 June. No repairs have been made on the site since the bombing of 27 May.

Air Cover: Sortie 15/102 Photo nos. 5002-3  
of 2 June 1944.

- 4.
- COMBATTANT-SUR-OISE
- Ref. Map: G.S.G.S. 4250/731/076702

The following is the situation at the four-gun light casemate battery after bombing of 1 June:

No. 1 casemate: Complete and undamaged.

No. 2 casemate: Undamaged. Roofing in progress.

No. 3 casemate: Complete and undamaged.

No. 4 casemate: Complete and undamaged.

Both of the two remaining open emplacements sustained direct hits. Half of one emplacement has been demolished, the other only slightly damaged, contains an object which may be a gun.

Air Cover: 15 15/102 Photo nos. 5006-7  
of 2 June 1944.

DECLASSIFIED

DATE: 278 278 BY: 278 278  
REASON: 278 278 278 278

CONFIDENTIAL TOP SECRET  
BIGOT

/E. Other Reports..

0 2 4 4



BIGOT

- 2 -

B. Other ReportsCHEPANIRef. Map: GSGS 4250/72/5.  
905824

Two more occupied emplacements are seen at this previously reported possible field battery, making a total of eight occupied emplacements.

Air Cover: Sortie 400/192  
of 2 June 1944

Photo Nos. 3355-6

2. LE MARTEL

Ref. Map: GSGS 4250/72/2/  
04677457

Four emplacements 24 feet in diameter, 57-55 yards apart, are visible here. Three emplacements are unoccupied, and No. 2 contains a high camouflaged object very unlike a gun. There is a marked absence of track activity.

Air Cover: Sortie 400/193  
of 2 June 1944

Photo No. 4112

3. ST. COME DU MONT

Ref. Map: GSGS 4347, Sheet 31/  
18SE, 383884

Date of Inf.: 31 May 1944

Four emplacements in a hedgerow, probably occupied. Diameter, 32 ft.; distance apart (right to left) 135 ft. - 140 ft. - 125 ft. Centre line NNW.

There are six small pits in an adjacent hedge-row, two weapon-pits at 3838846 and 38258855 respectively, and a dug-out at 38358830.

Air Cover: Sortie 30/4043

Photo No. 1041-2

Comment: The direction of fire is curious. If this is a field battery as seems most likely, it would appear to be sited for the protection of CARENTAN against land forces.

4. VILLIERS-LE-SEC

Ref. Map: GSGS 4347, Sheet 37/  
18SE, 896807

Date of Inf.: 2 June 1944

Possible field artillery position in hedgerow.

Air Cover: Sortie 400/192

Photo No. 4409-10

5. LE PAVILLON

Ref. Map: GSGS 4347, Sheet 37/  
18SE, 892829

Date of Inf.: 2 June 1944

Possible field artillery or projector position in hedgerow.

Air Cover: Sortie 400/192

Photo No. 3410-1

/Comment

TOP SECRET  
BIGOT

0 2 4 5



TOP SECRET  
BIGOT

- 3 -

Comment: Both this and the VILLIER-LE-SEC position are in a possible Verrier area. Compare the position at 901823 South of CREPCN, already reported

6. CHANTRAL

Ref. Map: GSGS 4347, Sheet 34/  
1888, 604897

Date of Inf: 3 June 1944

Possible four-gun field battery, in a line of trees. The guns are 50 yards apart. Trenches running to dugouts 60 yards in rear of the position appear to be possibly faked, however.

Air Cover: Sertie 16/338

Photo No. 4127

G-2 (Intelligence) Division,  
SHAEP  
4 June, 1944

TOP SECRET  
BIGOT

0 2 4 6

TOP SECRET  
BIGOT

TOP SECRET

APPENDIX "B" TO REFERENCE MAP NO. 38  
Dated 2 June 1944.

## FLAK IN THE NEPTUNE AREA.

1. HERNOUVILLE-SUR-ORNE. Reference Map: G.S.G.S. 4347/40/16 NW.  
Between FLAMETOT and HERNOUVILLE, at 056794, there is a four-gun heavy Flak position. Nearby, are a three-gun light Flak position, at 058793 and a searchlight at 058793. The entire site is possibly a Gury one, in spite of a certain amount of track activity.  
Air Cover: Sertie: 400/182 Photo Nos: 3119-20.  
of 30 May 44.
2. CHESSERONS. Reference Map: G.S.G.S. 4347/40/16 NW.  
At 040797 a possible three-gun light is under construction, EAST of CHESSERONS.  
Air Cover: Sertie: 400/193 Photo No: 4073.  
of 2 Jun 44.
3. HERNOUVILLE. Reference Map: G.S.G.S. 4347/40/16 NW.  
Beside the bridge over the River ORNE, EAST of HERNOUVILLE, at 10057430, is a probable light Flak tower.  
Air Cover: Sertie: 400/193 Photo Nos: 4074-5.  
of 2 Jun 44.
4. CHATEAU DE LA LOUPE. Reference Map: G.S.G.S. 4347/40/16 NW.  
EAST of the Chateau, at 038738, there is a possible three-gun light Flak position under construction.  
Air Cover: Sertie: 400/193 Photo Nos: 4084-5.  
of 2 Jun 44.
5. LA QUENNERIE. Reference Map: G.S.G.S. 4347/31/18 NE.  
There is a three-gun light S.P. Flak battery in a field SOUTH of ETEENVILLE, at 26029478. The guns are in rectangular emplacements, 32 feet by 20 feet, heavily banked up with earth. Nearby is a circular emplacement occupied by an unidentified object.  
Air Cover: Sertie: 31/445 Photo Nos: 2066-7.  
of 24 May 44.
6. GRANVILLE. Reference Map: G.S.G.S. 4250/62/5.  
There are 6 light railway Flak waggons in the sidings at 1234.  
Air Cover: Sertie: 16/375 Photo Nos: 4077-8.  
of 2 Jun 44.
7. RAYEUX. Reference Map: G.S.G.S. 4347/37/18 SW.  
The following Flak positions are seen in the vicinity of RAYEUX in Sertie 400/192:

782307	3 light unoccupied	3012-3
817779	2 emplacements for heavy guns	4346
818773	3 light	4346
797797	3 light unoccupied	4009

/782755...

REF ID: A66547  
TOP SECRET  
BIGOT  
9SPIC

0 2 4 7

TOP SECRET  
BIGOT

-2-

782755	3 light	3009-10
782786	3 light unoccupied	3007-8
792787	3 light unoccupied,	3007-8
	20 ammunition bunkers	
	nearby	
782781	3 light 1 unoccupied	3006-7

Air Cover: Sortie: 400/192  
of 2 Jun 44.

8. HERLANVILLE-SUR-MER.

Reference Map: G.S.G.S. 4347/40/16 NW.

The position at 056794 (see above) is now thought to be a genuine four-gun heavy Flak position and is occupied. The emplacements for the three light guns and the searchlight are unoccupied; they are probably still under construction.

Air Cover: Sortie: 400/193  
of 2 Jun 44.

Photo Nos: 4119-20.

9. CAEN.

Reference Map: G.S.G.S. 4347/40/16 NW.

The heavy Flak position NORTH of CAEN, at 043706, has been re-occupied. The position now contains four heavy and three light guns and a searchlight.

Air Cover: Sortie: 400/193  
of 2 Jun 44.

Photo Nos: 4103-4.

10. LE MESNIL.

Reference Map: G.S.G.S. 4347/40/16 NW.

NORTH of LE MESNIL, at 021757, is a probable three-gun light Flak position.

Air Cover: Sortie: 400/182  
of 30 May 44.

Photo Nos: 3178-9.

G-2 (Intelligence) Division,  
S.M.A.E.P.

TOP SECRET  
BIGOT

0 2 4 8



## BIGOT

- 2 -

7. ES CLEGGES Reference Map: G.S.G.S. 4347, 28-22 Composite.  
Date of Information: 31 May 1944  
Probably occupied vehicle loop at 967291.  
Air Cover: Sortie 16/359 Photo Nos: 4194  
of 31 May 1944
8. FLOTTEMANVILLE-  
HEAINE Reference Map: G.S.G.S. 4347, 28-22 Composite.  
Date of Information: 31 May 1944  
Three unoccupied emplacements with internal diameter of 10 feet sited in an arc approximately 180 feet apart at 094224 and a further three sited in an arc at 052235. Slit trench from 094220 to 090218.  
Air Cover: Sortie 16/359 Photo Nos: 4179/81  
of 31 May 1944  
Comment:  
There is insufficient evidence to say whether these positions are for projectors (Werfers) or mortars.
9. CARPIQUET Reference Map: G.S.G.S. 4347, 37-16 SE.  
Date of Information: 2 June 1944  
Four vehicle loops at 975688.  
Air Cover: Sortie 40Q/193 Photo Nos: 4232/3  
of 2 June 1944
10. CREANVILLE Reference Map: G.S.G.S. 4347, 34-18 SW.  
Date of Information: 27 May 1944  
Troops located in buildings at 51405710. There are approximately nine weapon pits and a length of trench, partially concealed in hedgerows, adjoining these buildings.  
Air Cover: Sortie 106G/521 Photo Nos: 3008/9  
of 27 May 1944
11. CREANCES Reference Map: G.S.G.S. 4347, 31-16 NW.  
Date of Information: 31 May 1944  
Trenches at 153744 and 156747. The town of CREANCES appears to be occupied by troops. A road loop at 153745.  
Air Cover: Sortie 16/362 Photo Nos: 4103/4  
of 31 May 1944
12. ORCHANNES Reference Map: G.S.G.S. 4347, 31-18 NE.  
Date of Information: 31 May 1944  
Continuous trench from 26009806 to 26459785.  
Air Cover: Sortie 30/404.2 Photo Nos: 1035  
of 31 May 1944

/13.....

TOP SECRET  
BIGOT

0 2 5 0

TOP SECRET  
BIGOT

- 3 -

13. SUREMAYVILLE Reference Map: G.S.G.S. 4347, 28-22 Composite.

Date of Information: 31 May 1944

Small shelter under construction at 088263.

Air Cover: Sortie 16/359 Photo Nos: 3111  
of 31 May 194414. ISEMNY Reference Map: G.S.G.S. 4347, 34-18 SW.

Date of Information: 2 June 1944

A number of small pits at 49868570 and 50006577.

Air Cover: Sortie 1066/652 Photo Nos: 3004/5  
of 2 June 194415. PERIERS-sur-le DAN Reference Map: G.S.G.S. 4347, 40-16 NW.

Date of Information: 2 June 1944

Four new vehicle bays at 04477825, 04467810, 04687770 and  
04827768.Air Cover: Sortie 400/193 Photo Nos: 4076/7  
of 2 June 194416. BENOUVILLE Reference Map: G.S.G.S. 4347, 40-16 NW.

Date of Information: 2 June 1944

Vehicle loops at 09777547, 10057566, 10137578, 10207590,  
10367615, 10457628 and 10557642. The two cupolas already reported at  
102763 are now seen to be on top of shelters. Two runways lead from  
the Northernmost shelter to two probable A.Tk gun emplacements. In  
addition there are two probable shelters and three probable pillboxes  
in this strongpoint.Air Cover: Sortie 400/193 Photo Nos: 4057/8  
of 2 June 194417. LA ROSIERE Reference Map: G.S.G.S. 4347/37/18 SW

Date of Information: 2 June 1944

Three dugouts at 831844 and one probably under construction at  
826843.Air Cover: Sortie 400/192 of Photo Nos: 4034/6  
2 June 194418. STIENVILLE Reference Map: G.S.G.S. 4347/31/18 NE

Date of Information: 31 May 1944

Three groups of small pits and earth disturbances indicate possible  
artillery position at 27629465. These positions are NOT emplacements.Air Cover: Sortie 30/4042 of Photo Nos: 1136/7  
31 May 1944

Comment:

Unlikely to be Field Artillery position.

TOP SECRET  
BIGOT

/19. B.YEMK....

0 2 5 1



TOP SECRET  
BIGOT

- 4 -

19. BYSIAReference Map: G.S.G.S. 4347/37/16 NWDate of Information: 2 June 1944

Small circular pits approximately eight feet in diameter at 831738, 834741, 835739, 834775, 829773, 822772, 824772, 826772, 821768, 805781, and 805785.

Air Cover: Sortie 400/192 of Photo Nos: 4007, 4067, 4110, 4387.  
2 June 1944

20. SENVILLEReference Map: G.S.G.S. 4347/26/20 SEDate of Information: 2 June 1944

Two unidentified infantry emplacements at 995008.

Air Cover: Sortie 16/572 of Photo Nos: 4049  
2 June 1944.

21. CREPON AirfieldReference Map: G.S.G.S. 4347/37/18 SE/916823Date of Information: 2 June 1944

Four small emplacements along one of the ditches obstructing the airfield. Possible for Machine Guns.

Air Cover: Sortie 400/192 Photo Nos: 3153-4

G-2 (INTELLIGENCE) DIVISION  
SHAEP.  
4 June 1944.

TOP SECRET  
BIGOT

0 2 5 2

TOP SECRET REF. BUREAU.  
 dated 4 June 1944.  
**BIGOT**  
OB. FACIES IN THE NEPTUNE AREA.

A. Anti-air-landing Obstacles.

1. ST JEAN DE BAYE

Map Reference: GSGS 4347/34/16 NW.

All flooded areas on this map sheet have dried up and are being obstructed with anti-air-landing obstacles, probably posts. See, for example, the flooded area at 4377 on the photos quoted below.

Air Cover: Sortie 30/4094 of 31 May 1944. Photo Nos. 1114-5.

B. Ditches.

2. QUERVENNE.

Map Reference: GSGS 4347/31/20 SE.

Two rows of unidentified obstacles can be seen along the bottom of the anti-tank ditch at QUERVENNE from 37450358 to 37520370. From this point they extend across the sand dune to the end of the sea-wall at 37550856.

Air Cover: Sortie 1062/652 of 2 June 1944. Photo Nos. 3186-7

C. Road-blocks.

3. COSQUEVILLE.

Map Reference: GSGS 4347, Sheet 31/22 SE.

The road from the sea, East of COSQUEVILLE, is blocked by two staggered concrete walls "en chicane" at 30102925. Level with the block, on the East side of the road, is a sunken shelter.

Air Cover: Sortie 16/294 of 27 May 1944. Photo Nos. 3087-88.

4. HAZEN.

Map Reference: GSGS 4347, Sheet 37/18 SE.

A belt of wire has been laid around the eastern side of the Chateau de HAZEN, running from 820820-822830-820832.

Air Cover: Sortie 16/345 of 30 May 1944. Photo Nos. 4204-5.

5. VIESCH.

Map Reference: GSGS 4347, Sheet 37/16 SE.

The road North of VIESCH is blocked at 960665.

Air Cover: Sortie 400/182 of 30 May 1944. Photo Nos. 3301-02.

D. Underwater Obstacles.

6. GRANVILLE.

Map Reference: GSGS 4347/31/12 NW & SE.

(a) 3 rows of Underwater obstacles of unspecified type now extend as follows:- 127307-128295-129283; 127300-128206; 127306-127293-127280.

TOP SECRET  
BIGOT

CONTAINS IN THE KRYPTON AREA.

A. Anti-air-landing Obstacles.1. ST JAMES BAY.

Map Reference: GSGS 4347/34/16 NW.

All flooded areas on this map sheet have dried up and are being obstructed with anti-air-landing obstacles, probably posts. See, for example, the flooded area at 4377 on the photos quoted below.

Air Cover: Sortie 30/4034 of 31 May 1944. Photo Nos. 1114-5.

B. Ditches.2. QUEBEVILLE.

Map Reference: GSGS 4347/31/20 SE.

Two rows of unidentified obstacles can be seen along the bottom of the anti-tank ditch at QUEBEVILLE from 37450858 to 37520379. From this point they extend across the sand dune to the end of the sea-wall at 37550836.

Air Cover: Sortie 1061/652 of 2 June 1944. Photo Nos. 3106-7

C. Road-blocks.3. COSQUEVILLE.

Map Reference: GSGS 4347, Sheet 31/22 SE.

The road from the sea, West of COSQUEVILLE, is blocked by two staggered concrete walls "en chicane" at 30102925. Level with the block, on the West side of the road, is a sunken shelter.

Air Cover: Sortie 16/294 of 27 May 1944. Photo Nos. 3037-33.

4. LAGNY.

Map Reference: GSGS 4347, Sheet 37/18 SW.

A belt of wire has been laid around the eastern side of the Chateau de LAGNY, running from 820820-822830-820832.

Air Cover: Sortie 16/345 of 30 May 1944. Photo Nos. 4204-5.

5. VESCHY.

Map Reference: GSGS 4347, Sheet 37/16 SE.

The road North of VESCHY is blocked at 960665.

Air Cover: Sortie 400/132 of 30 May 1944. Photo Nos. 3301-02.

D. Underwater Obstacles.6. GRANVILLE.

Map Reference: GSGS 4347/34/12 NW &amp; SW.

(a) 3 rows of Underwater obstacles of unspecified type now extend as follows:- 123307-123295-129283; 127300-128206; 127306-127293-127288.

(b) Stakes are seen lying on the beach ready for erection between 125355 and 127365.

(c) 9 units of possible tetrahedra are seen between 124355 and 124357.

Air Cover: Sortie 16/373 of 2 June 1944. Photo Nos. 4095-5 & 3080-2.

7. POINTE DU ROZEL.

Map Reference: GSGS 4347/26/20 SE.

A single row of staggered tetrahedra or hedgehogs is seen between 970064 and 971068.

The 2 rows of staggered ramps previously reported opposite SUSTANVILLE now extend northwards from 979043 to 978045.

Air Cover:

CONFIDENTIAL TOP SECRET  
BIGOT

TOP SECRET  
BIGOT

- 2 -

Air Cover: Sertic 16/372 of 2 June 1944. Photo Nos. 4037 and 4042.8. LE HONN. DE L'EST.Map Reference: GSGS. 4347/40/16 NE.

Stakes and ramps are seen to be connected by cables from 167795 to 170795 and from 163796 to 170796.  
Eight concrete boxes are seen between 170797 and 177797.

Air Cover: Sertic 16/385 of 3 June 1944. Photo Nos. 4050-3.9. LE HONN. DE L'EST.Map Reference: GSGS. 4490/73.

Six unidentified obstacles are seen at the back of the beach at 4458977B.

Air Cover: Sertic 16/386 of 3 June 1944. Photo Nos. 4060-1.10. ROCHES DE GRANICAMP.Map Reference: GSGS. 4490/77.

Eleven possible concrete boxes and three scars, which are possibly excavations for a 12th, are seen at 512931 (see tracing attached). They are sited in pairs forming a double row. The distance between units varies from 70 to 150 feet, and the distance between rows varies from 60 to 135 feet. They appear to be about 5 feet square and have considerable depth.

Air Cover: Sertic 16/386 of 3 June 1944. Photo Nos. 4113-4.11. GRANICAMP LES BAINS.Map Reference: GSGS. 4490/77.

A group of about nine scattered obstacles, which was previously reported in the area of 550936 and later thought to have been removed, is seen on the latest cover to be still in the same area. (See tracing attached).

Air Cover: Sertic 16/386 of 3 June 1944. Photo Nos. 3079-82.12. NEVAJINVA.Map Reference: GSGS. 4490/70.

Rather heavy cover of this area shows that the strip of element 'C' in the area of 573150 is interspersed with unidentified white objects of varying shapes and dimensions. A row of similar white objects appears between 574152 and 573147.

Air Cover: Sertic 16/386 of 3 June 1944. Photo Nos. 3011-2.13. LE HONN. DE L'EST.Map Reference: GSGS 4490/86.

A tracing is attached showing the latest additions in this area. The following features are noted:

- (a) Poles 20 ft to 25 ft long are seen being transported by horse and cart from a yard at 07173147 to the beach at 07568145, where the ramps have been extended.
- (b) A small group of about 19 block objects, which may be teller-mines are seen on the beach at 03073110. A similar stack of 47 can be seen at 09638038.
- (c) Thin stakes previously reported at 09578067 now appear to be wired together.
- (d) Seven of the stakes in the double row at 05708098 have been wired together.

Air Cover: Sertic 16/385 of 3 June 1944. Photo Nos. 3020, 3028, 4024./(14) LIC - SUR - MER:TOP SECRET  
BIGOT

0 2 5 5

TOP SECRET  
BIGOT

14. LAG - BUE - JEE Map Reference GSGS. 4490/85.

In addition to the work in progress on rafts, shown on the attached tracing, the following amendment should be noted on this map sheet:

The stretch of unidentified obstacles between 058818 and 070818 cannot be seen on the latest cover and should be deleted.

Air Cover: Sertic 16/385 of 3 June 1944. Photo No 3019.

15. PONTE DE S. JEE Map Reference GSGS. 4490/69.

A row of tetrahedra is seen between 42451800 and 42151790.

Air Cover: Sertic 16/386 of 3 June 1944. Photo Nos 4005-6.

G-2 (Intelligence) Division,  
C. H. A. C. E.  
4 June 1944.

TOP SECRET  
BIGOT

0 2 5 6

TOP SECRET  
BIGOT

Issued with Appendix F to NEPTUNE ARGUS NO. 28 dated 4 June 44.

TOP SECRET

96

06

01

02

G.S.G.S. 4490. Sheet 81. PENNINGTON 1:12,500.

The information below is additional to that shown on the tracing issued in the NEPTUNE ARGUS NO. 30.  
Serial 16/385 of 3 June 44.

Additional raft  
(probably 8)

45

46

96

96

G.S.G.S. 4490. Sheet 74. MEDVILLE-LEWISPORT  
1:12,500

The information below is additional to that shown  
on the tracing issued in the NEPTUNE ARGUS NO. 37.

Serial 16/386 of 3 June 44.

Unidentified  
obstacles

G.S.G.S. 4490. Sheet 71. QUINEVILLE 1:12,500.

The information below is additional to that shown on the tracing issued in the NEPTUNE ARGUS NO. 21.  
Serial 16/286 of 3 June 44.

Group of 7-15 unidentified obstacles,  
possibly stakes.

08

30

08

39

G-2 (Intelligence) Division.

S.H.A.E.F.

4 June 44

TOP SECRET  
BIGOT

0 2 5 7



TOP SECRET  
BIGOT

Issued with Appendix F to NEPTUNE ARGUS NO. 28 dated 4 June 44.

TOP SECRET

G.S.G.S. 4400. Sheet 77 GRANDCAMP 1:12,500

The information below is additional to that shown on the tracings issued in the NEPTUNE ARGUS NO. 27. Surtie 16/386 of 3 June 44. Photo Nos. 3079-02.

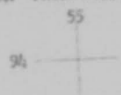

9 scattered unidentified obstacles



G.S.G.S. 4400. Sheet 80 COLLEVILLE 1:12,500

The information below is additional to that shown on the tracing issued in the NEPTUNE ARGUS NO. 27. Surtie 16/386 of 3 June 44. Photo Nos. 4136-40.



Extension to closely spaced ramps between Element 'C'

Lines of stakes  
(? ramps w/c)



G.S.G.S. 4400. Sheet 77 GRANDCAMP 1:12,500

The information below is additional to that shown on the tracing issued in the NEPTUNE ARGUS NOS. 26 & 27. Surtie 16/386 of 3 June 44. Photo Nos. 4113-4.

11 possible concrete boxes

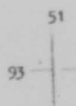

Excavation possibly for box.

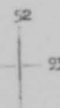

G-2 (Intelligence) Division,  
S.E.A.S.P.  
4 June 44

TOP SECRET  
BIGOT

0 2 5 8

TOP SECRET  
BIGOT

Issued with Appendix I to DEPTINE ARMO NO 38  
Dated 4 June 1944.  
Carte 16/305 of 3 June 1944.  
G.S.G.S. Map, Sheet 66, OUISTREMAN 1:10,000 tracing 'A' (West).

TOP SECRET.

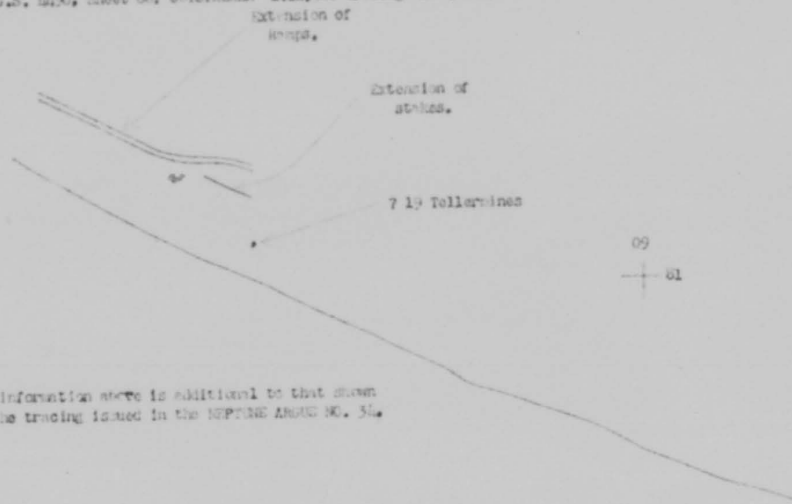

The information above is additional to that shown  
on the tracing issued in the DEPTINE ARMO NO. 38.

0-2 (INTEL. DIVISION)  
STAFF.  
4 June 1944.

TOP SECRET  
BIGOT

0 2 5 9

Included with Appendix B to REPORT ARJUN NO. 39, dated 1 June 1954.  
 Reference: ARJUN, Sheet 59, 500-030-030, 1114,500

The information below is additional to information on the "Wasting"  
 found in the REPORT ARJUN NO. 39,  
 Article 1675-C of 3 June 1954

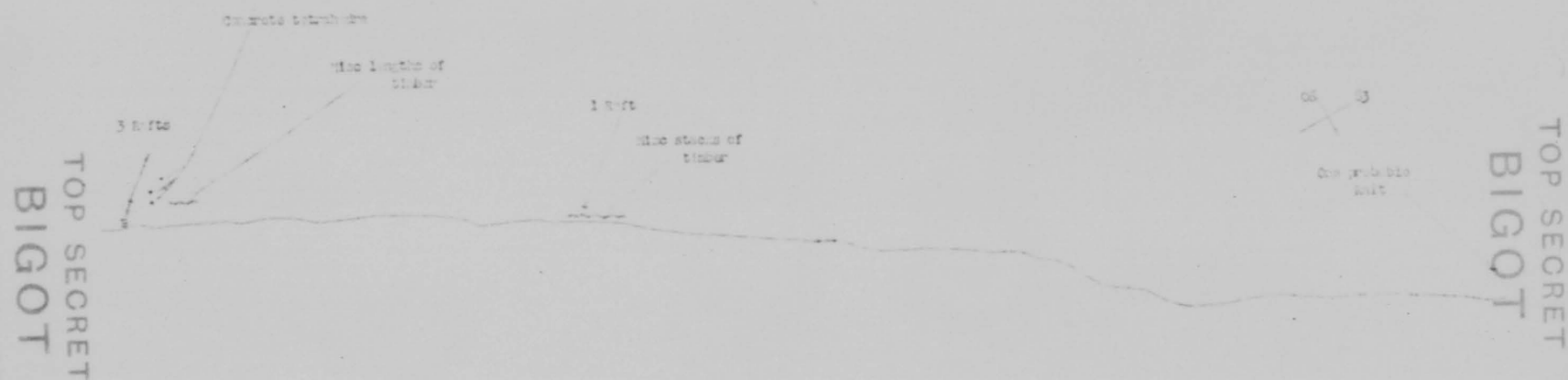

SECURITY DIVISION  
 1 June 1954

0 2 6 0

BIGOT

TOP SECRET.

Issued with Appendix E to REPORT AROSI NO. 18 dated 4 June 1950.  
 C.I.C.S. 4400, sheet 74, PARSIFAY, 1002900  
 Serial 10/586 of 3 June 1950.

The information below is additional to  
 that shown on the tracing issued in the  
 REPORT AROSI NO. 21.

39  
 + 7

Group of approx. 5  
 unidentified obstacles

Group of 3 unidentified  
 obstacles

One unidentified obstacle

06  
 + 39

Small group of  
 unidentified obstacles.

Shoreward row of  
 curved rail possibly  
 connected by wire.

06  
 + 05

C-2 (ATTACHMENT) DIVISION  
STAFF.  
 4 June 1950.

TOP SECRET  
 BIGOT

0 2 6 1

TOP SECRET  
BIGOT

All materials in  
this area are not  
to be identified as  
such and destroyed  
in accordance with  
the instructions.

1. 2. 3. 4. 5. 6. 7. 8. 9. 10. 11. 12.

The information below is additional to that  
shown on the routing slip in the header  
AGORD NO. 24

TOP SECRET

SECRET  
TOP SECRET (CONFIDENTIAL) 1-1

10  
+

TOP SECRET  
BIGOT

7 17 following

10  
11

This stage  
not used.

Issued with Appendix 2 to Section AGORD NO. 30 dated 4 June 1954.  
AGORD NO. 24, under 05, CIPHERS, 111,200 (ending 1st (part).  
AGORD NO. 24, under 16/100 of 3 June 1954.

0 2 6 2

Issued with Appendix E to NEPTUNE AGONIE NO. 30 dated 4 June 1944.  
 O.S.S. MAP, Sheet 86, CHRISTMAS 1:12,500 Tracing 'B' (East)  
 Air cover: Route 16/50 of 3 June 1944

TOP SECRET.

The information below is additional to that  
 shown on the tracing issued in the NEPTUNE  
 AGONIE NO. 30.

TOP SECRET  
 BIGOT

TOP SECRET  
 BIGOT

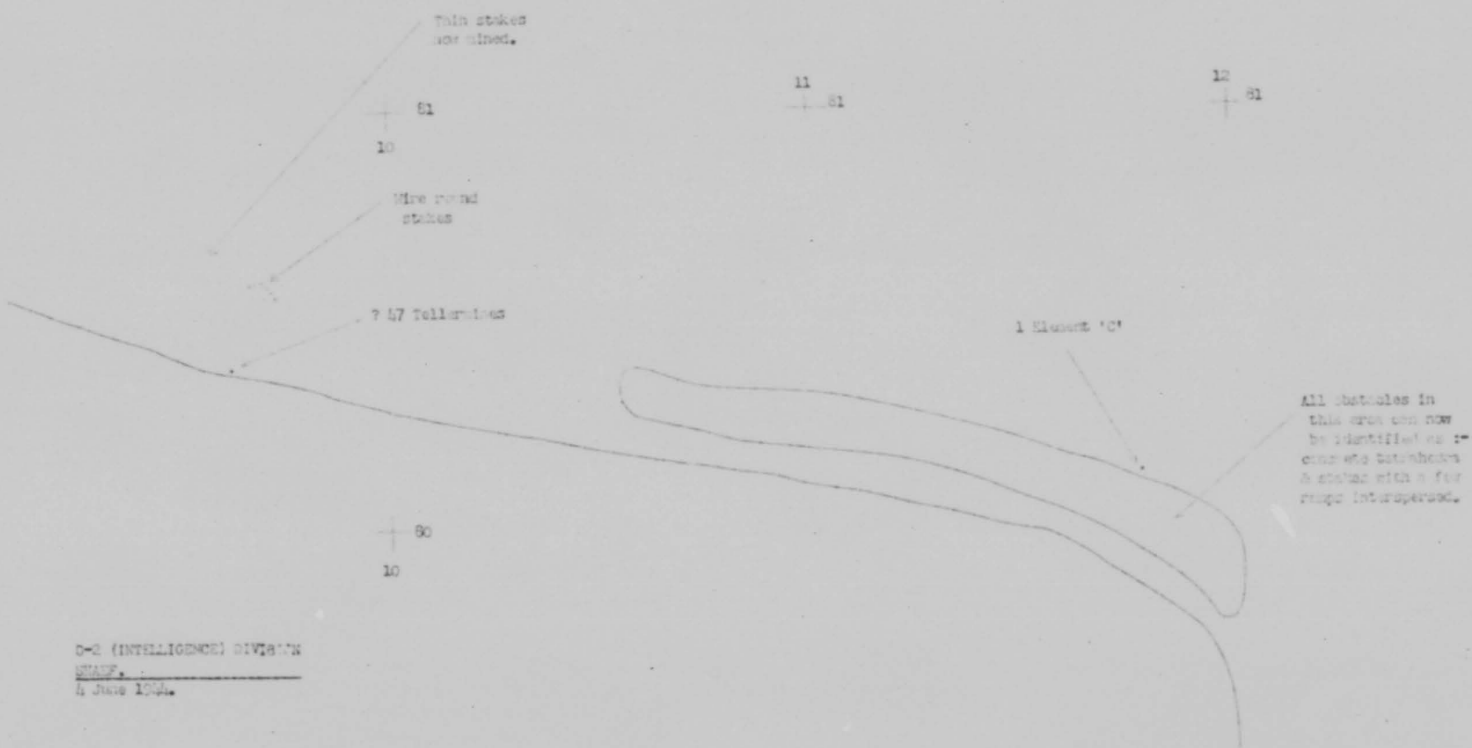

0 2 6 3



TOP SECRET  
BIGOT

TOP SECRET

APPENDIX 'F' TO NEPTUNE ARGUS NO. 38  
Dated 4 June 1944Minefields in the NEPTUNE Area

- 1.
- GRANVILLE
- Reference Map: 4250/07/5

Mines are visible within the wire belt on the NE side of the strongpoint at 130325.

Air Cover: Sortie 16/373 of 2 June 1944 Photo Nos: 4088-9

- 2.
- LION-SUB-LEER
- Reference Map: 4347/40/16NW

Two belts of wire, possibly enclosing mines, extend from 06158195 to 06258180.

Air Cover: Sortie 400/182 of 30 May 1944 Photo Nos: 3115-6

- 3.
- LES PIEUX
- Reference Map: 4347/28/20SE

On the coast due West of LES PIEUX at 968097 is a 4-row minebelt about 280 ft. long with rows about 5 ft. apart.

Air Cover: Sortie 16/372 of 2 June 1944 Photo Nos: 4032

- 4.
- LE ROZEL
- Reference Map: 4347/28/20CE

South of the river at LE ROZEL a minebelt containing six or seven rows extends for a distance of about 630 ft. from 977073 to 976075 between four lines of wire.

Air Cover: Sortie 16/372 of 2 June 1944 Photo Nos: 4036

- 5.
- TOURLAVILLE
- Reference Map: 4347/31/22SW

NE of TOURLAVILLE a small minefield extends along the South side of the road leading from the road junction at 19202358 to 19062360.

Air Cover: Sortie 16/359 of 31 May 1944 Photo Nos: 4031-2G-2 (Intelligence) Division,  
SHAEP.  
4 June, 1944.CONFIDENTIAL  
APPROPRIATE AGENCIES AND FIELD OFFICES SHOULD BE ADVISED BY ROUTING SLIP(S) OF THIS INFORMATION.  
95PICTOP SECRET  
BIGOT

0 2 6 4

TOP SECRET  
BIGOT

TOP SECRET

APPENDIX 'I' TO REFERENCE MAP NO. 30.  
Dated 4 June 1944.Signals Installations in the HERAUNE Area.1. SEE EN SAIL

Reference Map: 4250/70/4

A Radar Station is under construction at 157063.

Air Cover: Sortie BA/150 of photo Nos: 5030/9  
23 April 44.Date of Information: 23 April 44.Comment:

This will be a link in the inland Ground Controlled Intercept chain.

2. CHERBOURG/N. CAPEVILLE

Reference Map: 4250/52/2

Source reports the presence of an aircraft reporting message center (heldekopf BLK) in FORT N. CAPEVILLE, a former French defence work, at 059270. There are ZW/T receivers in each of the underground shelters between each of the French gun positions. There is a transmitter in the S.E. corner of the fort.

Air Cover: Sortie 16/294 of photo Nos: 4143/4  
27 May 44.Date of Information: Undated.Comment:

Air cover though confirming the layout of hutments in the fort area as indicated in source's sketch does NOT show any trace of serials above the underground shelters. A frame array (described by source as 'rececteur de file') is seen however in the centre of the fort in front of the gun. Heldekopf BLK is known to be in the CHERBOURG area and this might well be its location.

3. PARIS/NETTE (SEINE)

Reference Map: 4250/10P5/99847

No. 43 AVENUE DU GENERAL FAYOLLE, near the PORTE DAUPHINE, is occupied by German technicians and officers, engaged on secret operations, in transmission and reception of Z/T, especially on very short and ultra short waves. The engineers here are in constant touch with the KRIEGSMARINE.

Air Cover: None. Date of Information: Undated. Received  
30 April 44.Comment:

The CHATEAU DE LA NETTE, and near-by buildings on the edge of the BOIS DE BOULOGNE, opposite the BOULEVARD LAFAYETTE, have been reported as occupied by the German Navy and to have large serial arrays. In view of its close proximity, the station at No. 43 AVENUE DU GENERAL FAYOLLE is probably one of the adjacent buildings to which reference was made previously.

/4. CHATELoup..

CONFIDENTIAL

95210

TOP SECRET  
BIGOT

0 2 6 5

TOP SECRET  
BIGOT

- 2 -

4. CHANTELOUP (ILLE ET VILAIN) Reference Map: 40408/90 RE/0436 approx.

Radio transmitter West of CHANTELOUP village at 47° 51' N.  
01° 42' E. There are two masts, and the station is operated by 45 men of a  
navy signals unit.

Air Cover: None

Date of Information: March 44.

Comment:

This is believed to be the only transmitter for Fighter Command 4,  
(which controls area between OISE river and LOIRE river).  
Code name of station - RATTE.

5. VASS (SEINE) Reference Map: 4250/011/436987

There is an observation post, near the CHATEAU DE LA ROCHE, on  
the hill overlooking VASS along the road to CHATEAU DU LOIR.

Air Cover: None

Date of Information: April-May 44.

Comment:

It is not stated whether the post has

W/T.

6. La TRINITE (SURE) Reference Map: 4250/383/2564

This station is between VIEIL-EVREUX and La TRINITE, between the  
railway to the North and the road to the South.

Air Cover: None

Date of Information: Not known.

7. LE MEE (SEINE ET MARNE) Reference Map: 4250/1004/2305

To the West of LE MEE are 12 to 15 masts 80 metres high arranged  
in two East to West rows

Air Cover: None

Date of Information: Not known.

Comment:

This station transmits to G.A.F. and Navy. Described as a GROSSPUNK-  
SENDER (main W/T station).

8. CHAMPDUIL (SEINE ET MARNE) Reference Map: 40408/65 Ns/3114

W/T station with two 30 m. masts, is 10 kilometres NE of  
MELUN on South side of road from LISSY to CHAMPDUIL.

Air Cover: None

Date of Information: Not known.

Comment:

This is known as W/T "CORITZ".

G-2 (INTELLIGENCE) DIVISION  
SEAF.  
4 June 1944.

TOP SECRET  
BIGOT

0 2 6 6

TOP SECRET  
 To be treated as  
~~SECRET~~ until receipt  
 of signal "Open ON ONE"

25th May, 1944.

OPERATION NEPTUNE - PLYMOUTH COASTAL ORDERS

SIGHT TITLE - ON PLYMOUTH 2

SECTION I - INSTRUCTIONS FOR COVERING FORCES IN THE PLYMOUTH CHANNEL

INFORMATION

Enemy

The location of enemy naval forces is expected to conform generally to that given in OM 1, Appendix VII, Annex K. It is not anticipated that more than 2 Eibings will be operational, while M-Class minesweepers in greater numbers than shown may be at Cherbourg. It is possible that W-boats may be sent to operate in the Channel.

U-Boats have been sighted in the Channel, east of 5° west, and it is expected that up to 50 may move into the Channel at any time.

British

2. NEPTUNE convoys and bombardment ships with close escort will be proceeding on the coastal route from Bristol Channel to the assault area.

Support groups will be operating in the Channel, and in the approaches to the Bristol Channel, as the situation demands.

Fighter aircraft from 10 and 11 Groups A.D. S.B. will provide air protection for convoys.

Aircraft of 19 Group Coastal Command will maintain a continuous patrol over the Channel and South West Approaches by day and night, and will provide A/S escort for convoys. Other aircraft operating under 19 Group will be available for anti-shipping strikes by day and night.

Minefields

3. British minefields have been laid off Cherbourg, west of the Casquets and east of Roches Douvres, on the North Brittany Coast, and in the Ushant area. Their position is given in QZX messages.

FORCES TAKING PART

Destroyers - based on Plymouth

| <u>19th Division</u> | <u>20th Division</u> |
|----------------------|----------------------|
| TAYLOR Cdr. (D) 10   | RYKAWICKA            |
| ASLWYI               | BRKLO                |
| MAID.                | PICRIN               |
| HURON                | JAVELIN              |

Coastal Forces/.....

CONFIDENTIAL  
 95210

# 1071

71-2-133

0 2 6 7

ON PLYMOUTH 5  
SECTION I

- 2 -

25th May, 1944

Coastal Forces - based on Dartmouth/Brixham

|    |                      |                       |
|----|----------------------|-----------------------|
| 5. | 52nd M.T.B. Flotilla | 12 'D' Class M.T.B.'s |
|    | 65th M.T.B. Flotilla | 8 'D' Class M.T.B.'s  |
|    | 1st M.T.B. Flotilla  | 8 71' 6" M.T.B.'s     |
|    | 23rd M.T.B. Flotilla | 8 70' M.T.B.'s        |

A/S Support Groups

6. 3rd, 11th, 12th and 14th Support Groups. Will not form part of Covering Force, but may be operating in same area, or forming an extended convoy screen. Their primary function is anti U-boat, but they may find themselves in a position to operate against E-boats or destroyers.

Aircraft

7. (a) 19 Group

|                    |   |                      |
|--------------------|---|----------------------|
| Wellingtons        | } | Anti-shipping or A/S |
| Avengers           |   |                      |
| Swordfish (P.A.A.) |   |                      |
| Seafighters        |   |                      |
| Mosquitos          | } | A/S                  |
| Sunderlands        |   |                      |
| Liberators         |   |                      |
| Halifaxes          |   |                      |

(b) 10 Group

|              |   |                            |
|--------------|---|----------------------------|
| Albacores    | } | Anti-shipping              |
| Typhoons     |   |                            |
| Spitfires    | } | Fighter and Fighter Bomber |
| Lightnings   |   |                            |
| Thunderbolts |   |                            |

OBJECT

8. The object is to provide cover in the Plymouth Coast within the English Channel for operation NEPTUNE against destroyers and small surface craft, and in co-operation with support groups, against U-boats.

Cover is complementary to that provided in the Western portion of the Portsmouth Coast by Commander-in-Chief, Portsmouth

INTENTION

9. (a) To maintain a continuous patrol by destroyers to counter operations by the Narvik destroyers from Biscay ports and by the Torpedo Boats from Cherbourg.

(b) To reinforce/.....

0 2 6 8

ON PLYMOUTH 5  
SECTION I

- 3 -

25th May, 1944.

(b) To reinforce these patrols by night with coastal force units in the Lyme Bay area, with Wellingtons fitted with special equipment operating North and North West of the Channel Islands, and with Albacores operating near the convoy routes as a striking force.

(c) To attack the enemy with air striking forces from 10 Group R.A.F. whenever and wherever possible.

10. 19 Group Coastal Command aircraft will, in addition, carry out continuous patrol cover the Channel and South West Approaches, west of the line Portland Bill to Cap de la Hague, and F.A.A. Swordfish operated by 19 Group will provide A/S escort for convoys.

METHOD OF EXECUTION

11. Orders for establishing patrols will be signalled in the form shown in Appendix I. Positions may be signalled in detail, or ships may be ordered to occupy a numbered square, e.g. "Square Z 207", as denoted on charts which are now being distributed.

Intended method of operating Wellington aircraft

12. (a) Wellington aircraft will operate by night south of a line drawn 245 degrees from 50 degrees 08½' north 2 degrees 13½' west, and west of a line joining the above position to Cap de la Hague. In general the Wellingtons will remain north of the Channel Islands, and will operate as far as about 4 degrees west.

Wellingtons will report and shadow contacts. They have freedom to illuminate and attack all contacts within the above limits, but may continue to shadow and report outside this area. In the latter case they will not illuminate or attack unless ordered by either A.C.R.Q., Plymouth, or by V.R.F. by the Senior Officer of the destroyer patrol.

(b) Aircraft when shadowing are to endeavour to orbit within a radius of 2 miles of the contact but are not normally to approach the known position of our own forces within 5,000 yards. They will however "home" the destroyers until such time as the latter have obtained radar or other contact with the enemy. At this stage the Senior Officer Destroyers, in contact may request the aircraft to illuminate on a given bearing. Flares are to be dropped as near the enemy as possible on the bearing indicated but are on no account to be dropped between our own forces and the enemy. The dropping of flares/flashes as indicators may also be requested by our destroyer forces.

(c) Once contact has been made between the surface forces, the aircraft is to continue to orbit the scene of action and is to be prepared to provide further illumination, or to attack the enemy, if ordered by the Senior Officer Destroyers.

Destroyers

13. Destroyers will occupy a patrol line to be known as the HULL DEEP PATROL, running 245 degrees from position 50 degrees 12' north 2 degrees 21' west to approximately 49 degrees 56' north 3 degrees 16' west. Destroyers will be stationed singly and will carry out a turning line ahead patrol, turning together at the eastern end of patrol at odd hours and at western end at even hours. With four destroyers present they will be stationed 8 miles apart, the spacing being reduced if more are available.

The easternmost billet will be Patrol 1, the next Patrol 2, and so on.

14/.....

0 2 6 9





25th May, 1944.

- 5 -

PLYMOUTH 5  
SECRET

(b) When the R.A.F. and Naval Controller working together at King'sear or Treleaver have reason to believe that they are tracking enemy surface forces they are to endeavour to intercept them. Aircraft are only to attack, however, when permission is given by the R.A.F. Controller.

(c) Before giving permission to attack, the R.A.F. Controller is first to obtain sanction through the Naval Controller from C.C.H.Q., Plymouth.

(d) When asking permission to attack, the Naval Controller will use one of the following two phrases:-

"Propose to attack enemy ships plotted in.....square"  
which implies that the Controllers believe that the tracks they are plotting are hostile but require confirmation

OR

"Intend to attack ships plotted in.....square"  
which implies that the Controllers are quite sure that the tracks they are plotting are hostile from their behaviour.

A slight delay whilst information is being sifted at Plymouth C.C.H.Q. will have to be accepted before permission is given to attack after the passing of the first message whilst an immediate vote will be given to a request passed in the form of a second message if the operational picture is not clear.

Integration of Covering Forces

1. All covering forces are to endeavour to work as a team, making full use of information as it is received, and trying to anticipate the enemy's movements. It is of the highest importance that units operating while shore radar cover keep the Commander-in-Chief, Plymouth, informed of their position and movements, the briefest signals being used.

It is hoped that at night our aircraft will locate enemy forces and give time for the destroyers to move to an intercepting position; and again our coastal forces may be able to act on information from both aircraft and destroyers.

2. If an enemy has moved in past our patrols, he must be intercepted and his withdrawal, if not brought to action earlier.

E-boats move at 40 knots and more, so quick thinking is essential.

MESSAGE REPORTS

21. These are to be made as laid down in CR 1 paragraph 44.

COMMUNICATIONS

22. (a) Destroyers. In accordance with CR 100 PLYMOUTH 1

(b) Coastal Forces. In accordance with CR 100 PLYMOUTH 2

0 2 7 1

Distribution of On Plymouth 5, Section 1.

The Secretary of the Admiralty (6). Nav. Commander Western Task Force ( Naval Commander Eastern Task Force. Comforce "0". Comforce "1". Comforce "2" Comandantebeventhphib. Allied Naval Commander Expeditionary Force (5). Commander-in-Chief, Home Forces (2). Commander-in-Chief, Portsmouth (10). Commander-in-Chief, Western Approaches (50). Flag Officer-in-Charge, Milford Haven. Flag Officer-in-Charge, Cardiff. Flag Officer-in-Charge, Plymouth (3). Flag Officer-in-Charge, Portland (3). Naval Officer-in-Charge, Dartmouth (3). Captain Coastal Forces, Portsmouth (5). Captain (1), Liverpool. Captain (D), Plymouth. Air Officer Commanding-in-Chief, Coastal Command. Air Officer Commanding, 19 Group (10). Air Officer Commanding, 10 Group (6). Air Officer Commanding, 11 Group. Commanding Officers, H.M. Ships Black Bat, Cicala, Tartar, Eskimo, Ashanti, Javelin, Bennett, Essington, Barr Coke, Blackwood, Forester, Havelock, Hotspur, Inconstant, Icarus, Oarlow, Orsloght, Oribi, Offa, Wensleydale, Brissenden, Volunteer, Vigil, Redlicea, Bluebell, Argonaut, Nelson, Mendip, Blonathia, Pelican, Japsing, Hart, Apollo, Windrel, Harborough, Rupert, Whitaker, Woldgrave, Spruce, Stockton, Taty, Strule, Deveron, Wanderer, Watchman, Vanquisher, Koppel, Elmer, Shetland, Danella, Ceranium, Abelia, Balsam, Colandine, Dianthus, Heather, Gentian, Hincysuckle, Rhododendron, Dahlia, Harwood, Rodney, Verapate, Scyllia, Mauritius, Arctura, Probiar, B... Sirius, Orion, Amos, Scania, Diana Danae, Saumarez, Swift, Grenville, Ulster, Urekin, Undine, Glasgow, Black Prince, Bellona, Hawkins, Enterprise, Riou, Westcott, Bowley, L... Duckworth (2), Fame (2). Commanding Officers, H.M.C. Ships, Elin, Euron, Footway, Chaudiere, Catineau, Qu'aitelle, S... Anathaine, St. Laurent, Westigoucha, Summerside, Woodstock, Regina, Moosejaw, Port Arthur, Idaway, Ottawa (2), Saskatchewan (2). Commanding Officers, C.R.P. Algonquin, Piorun, Dragon. Commanding Officers, P.B. Acornit, Bonaville, Resolute, Montcalm, Georges Leygues. Commanding Officers, U.S.S. Haly, Nevada, Arkansas, Tuscaloosa, Quincey, Texas (9 - 1 & 8 for destroyers). Senior Officers, 65th M.T.B. Flotilla (8), 52nd M.T.B. Flotilla (10), 1st M.T.B. Flotilla (8), 23rd M.T.B. Flotilla (8). Commanding Officers, S.D.M.L.'s 1295, 1389, 1309. Commanding Officers, H.M. Barrage Minnowes Acanthus, Eglantine, Rose, Stord, Swenner.

APPENDIX I to ON FLEETMAN 5  
SECTION I

METHOD OF SIGNALING ORDERS FOR PATROL OF PATROLS

1. Destroyers and Coastal Forces

Patrol orders for Destroyers and Coastal Forces will be signalled in the following form:-

"ON FLEETMAN 5, SECTION I, Appendix I, Para. 1"

- (A) Force identity number and composition; Senior Officer.
- (B) (i) Time to pass gate.  
(ii) Time by which patrol is to be taken up.
- (C) Route to reach patrol line, if other than direct.
- (D) Details of patrol line.
- (E) Disposition of ships on patrol line.
- (F) Speed on patrol.
- (G) Information.
- (H) Special patrol orders.
- (J) Time to leave patrol.
- (K) Return route, if other than direct.
- (L) Communications. Call signs.
- (M) Code word.

2. Aircraft

Information of air patrols will be signalled in the form:-

"ON FLEETMAN 5, SECTION I, Appendix I, para. 2"

- (F) Type of aircraft.
- (G) Period of patrol.
- (H) Details of patrol.
- (S) Special orders for patrol.
- (T) Communications and call signs.

3. Only that information not available in ON FLEETMAN 5, Section I, or differences from the arrangements laid down will be signalled.

CONFIDENTIAL

95P10

0 2 7 3



0 2 7 4



0 2 7 5





0 2 7 6



0 2 7 7

FILE IN  
CLASSIFIED FILES

DECLASSIFIED  
EO 11652

Box - 31

E.T.O.

Don. File 312 filed

AF 1480

|                       |   |
|-----------------------|---|
| 502.152-1<br>44/00/00 | RETURN TO<br>AFSHRC<br>MAXWELL AFB AL 36112 |
|-----------------------|---|

5-443

1029151

Card 04

0 2 7 8

*pgc/...*  
SECRETAUTH: CG, PGC  
INIT: WLD  
DATE: 4/5/44

5 April 1944

*502.152-1  
44/00/00*

MEMORANDUM FOR: General S. P. Spalding

Re: Signal Plan - Special Shuttle Bombing Project.

1. In compliance with verbal request, a meeting of all signal and communication officers assigned to the Special Shuttle Bombing Project now at Teheran was held April 4, 1944. Those present were:

Colonel Thomas - Signal Officer, PGC  
Colonel Lancaster - USSTAF  
Lt Col Combel - PGC  
Lt Col Day - AACCS  
Major Callahan - USSTAF  
Captain Treece - SCS  
Captain Howe - AACCS  
Captain Neff - USSTAF  
Captain Newell - Air Surgeon  
Lieutenant Dubitsky - S.C. (Crypto)  
Lieutenant Long - A.C. (Comm. maint.)  
Lieutenant Rubin - S.C. (Comm. supply)  
Lieutenant Freshwater - A.C. (Flying Control)  
Lieutenant Carducci - A.C. (Flying Control)

2. Various phases of communication were discussed and the following conclusions reached:

a. Administrative Circuits. No definite permission has been obtained to establish any administrative circuits into or within Russia. The matter has been under consideration for several months but no favorable reply has been received from Moscow. Colonel Thomas has ordered equipment for the Russian station and it should be at Teheran in the near future. Colonel Thomas is prepared to establish a station in Russia upon short notice and to provide personnel for initial operation, it being understood that personnel for permanent operation will have to be supplied as soon as possible from some other source.

The question of establishing internal administrative circuits has not been clarified at this date, and no provisions have been made to provide communication between Moscow and the main

- 1 -

SECRET

SECURITY CLASSIFICATION  
DATE: 08/08/83  
BY: [unclear] R 30

0279

SECRET

American operational base. This internal circuit will become a necessity if administrative circuits are established between Moscow and Teheran, London or other points. It is felt that, if permission to establish administrative circuits is obtained from Moscow, a circuit should definitely be provided to Teheran as well as to other points. This is considered necessary in view of the fact that supplies will probably flow through the Persian Gulf Command.

Action required: Colonel Thomas will follow this matter closely and take whatever action is necessary, keeping Colonel Knoll advised.

b. Redline Operational Circuits. Based on instructions received from USSTAF and concurred in by the Air Communication Officer in Washington, Signal Airways Service (SAS) will install and Army Airways Communication System (AACS) will operate, under the operational control of USSTAF, redline operational circuits between UK, Italy and Russia. The stations at Widwing, England, and Naples (near Caserta), Italy, are under construction. Personnel and equipment for the Russian station are now at Teheran or enroute by air. SAS personnel consists of 1 officer and 10 enlisted men. AACS personnel consists of 2 officers (one, the officer in charge, the other, in charge of cryptographic problems) and 16 enlisted men. Four additional officers are accompanying the project and will remain in Russia until circuits have been established. It is understood that Major Spaulding, USSTAF Signals Officer, will exercise overall control of these circuits (type of traffic to be handled, channels of command, use of facilities, etc.) but that AACS will handle details of operation, including cryptographic problems. Basic equipment planned includes 8 each 3-KW transmitters and associated equipment and provides separate operational circuits between the three points in the net and a common weather circuit. It is anticipated that no administrative traffic will be handled on these circuits, but that they will be reserved for operational traffic only. Upon completion of installation work, SAS personnel will return to England and AACS will send in a similar number of personnel to assume operational functions.

Action required: Lt Col Day and Captain Treece are responsible for the installation and operation of these circuits and will take all action required. Captain Howe will contact proper authorities in Russia to obtain clearance for use of machine cryptographic devices. Inter-base cryptographic problems and other security problems will also be handled by Captain Howe.

c. Operational circuit - Russian base to Teheran. Under date of April 3, permission was requested from Moscow through General Deane for AACS to establish an operational circuit between the main

- 2 -  
SECRET

0 2 8 0

SECRET

American operational base and Teheran for the scheduling of aircraft in and out of the USSR. Equipment has already been procured by SAS and is now at Teheran. Basic unit consists of a single channel transmitter with an output of 200 watts and all associated equipment. This equipment weighs approximately 6000 lbs and has cubage of 350 cu. ft. AACS has personnel to operate station. The AACS facilities at Teheran will be utilized for this circuit.

Action required: Although permission has not as yet been obtained for this circuit, the equipment will be flown in immediately so that the circuit may be established instantly. Lt Col Day and Captain Trecce will take necessary action.

d. Inter-base communications. Major Spaulding is now in Russia and is investigating the possibility of using land lines between the various bases. Colonel Lancaster stated that one speech operational circuit, one speech administrative circuit and one teletype circuit should be provided between bases. Lieutenant Rubin stated that the speech requirements could be met with terminal equipment now on the way providing the Russians make the wire circuits available for American use. However, no teletype machinery or maintenance parts have been shipped. Lieutenant Rubin further stated that radio equipment (4 SCR 299's less tracks - 4 SCR 193's - 18 SCR 188's) for inter-base communications was now in England awaiting air shipment. Colonel Lancaster stated that no air priority had been established for this equipment. Lt Col Day stated that as an emergency measure, three complete radio installations for inter-base use had been assembled at Teheran by AACS and would be held for further disposition. No personnel for inter-base communications have been allotted by USSTAF. Colonel Thomas stated that he would do his utmost to assist in supplying personnel, if needed, for emergency operation.

Action required: Lieutenant Rubin will prepare a wire to England to be sent through Colonel Knoll's office asking that all radio equipment awaiting air shipment be expedited and inquiring regarding personnel to operate the inter-base facilities. Lieutenant Rubin will prepare a wire for Colonel Griffiths to be sent through Colonel Knoll's office stating that no teletype equipment has been ordered. If such equipment is to be ordered, action should be taken from Moscow immediately, together with request for personnel.

e. Flying Control. Flying control at the three bases will be handled by USSTAF personnel and equipment will be procured and installed by USSTAF Signal Corps personnel. Flying control personnel now at Teheran consists of three (3) officers and three (3) enlisted men. Three additional men for each station will be supplied. Colonel Lancaster stated that the number of personnel appeared inadequate. Equipment for use by flying control personnel (12 SCR 624's, 4 SCR 634's,

- 3 -

SECRET

0 2 8 1



SECRET

4 SCR-291's) is now enroute. Lt Col Day stated that 2 3-KW transmitters will be available for long range air-ground control of aircraft.

Action required: Lieutenant Freshwater will prepare a wire to England to be sent through Colonel Knoll's office inquiring as to status of shipment of the SCR 634's and SCR 291's and requesting that everything possible be done to expedite same.

f. Airborne radio equipment. Maintenance of aircraft radio will be handled by Lieutenant Long. None of Lieutenant Long's personnel has arrived as yet. All equipment is being shipped by boat. Lieutenant Rubin (Signal Corps Supply) stated that there were a few SCR 522 sets at Casablanca which he would like to obtain if possible.

Action required: Lieutenant Rubin will prepare a wire to be signed by Colonel Knoll and sent to Lt Col Roberts, Supply Officer, Service Group at Cazes Airport, Casablanca, asking whether or not the SCR 522 sets now on hand could be sent to Teheran for use on this special project, pointing out the urgency of the mission.

g. Radio aids to navigation. A radio range type MRLZ will be installed at one of the bases by SAS and operated by AACS. If felt necessary by those in charge, the SCR 188's can be installed for use as homing beacons or buncher beacons. This will await later determination.

Action required: Lt Col Day and Captain Treese will take action regarding the installation and operation of the range. No action will be required at this date regarding the installation of the SCR 188's.

3. The above work will be coordinated by all concerned in an effort to expedite the completion of the project.

*William L. Day*  
WILLIAM L. DAY  
Lt. Col., AC AACS

Teheran, Iran  
5 April 1944

- 4 -

SECRET

0 2 8 2

COMMENTS RECEIVED ON SIGNAL PLAN DRAFT BY WESTERN  
8 April, 1944

1. Paragraph No. 1 Requires no comment.

2(a) Communication between Poltava and Moscow is as follows:

The Soviets have given us permission to use their existing radio circuit between Poltava and the Red Army Airforce Headquarters, Moscow. Messages will be delivered to the American Embassy by courier.

Arrangements are being made for the following channel to Moscow.  
Poltava to widening commercial to Moscow and reverse.

2 (b) The question of sending AAF personnel to replace the G.S. Personnel will be taken up with Lt. Col. Day.

2 (c) Cable has already been sent to Teteran requesting transmitter for installation at Poltava.

2 (d) Soviets will furnish teletype and telephone communications between bases.

Cable sent to Teteran requesting radio equipment for the bases.

2 (e) No comments

2 (f) No comments

2 (g) No comments

*William E. Spaulding*  
William E. Spaulding  
Major Signal Corps

Re finance plan from Persian Gulf Command, General Deane has drafted a plan for Finance, Frantic Project which was submitted to FD, Washington and approved. Details of General Deane's plan which effect a change in the PGC plans were forwarded to PGC by cable.

*Aaron J. Boggs*

AARON J. BOGGS

Capt., CWS

*Proc Plan*

FINANCIAL --

- I. Class of office--
  - a. Account to disbursing office
    1. The base is the least denomination, with each line a smaller amount than the last.
- II. Function--
  - a. Finance Service & grant of the demand.
  - b. All payments will be in Federal Currency (unit being the unit of money).
- III. All issues in foreign exchange
  - a. Authorized in G Bulletin No. 10, Oct. 13, 1938, and Finance Bulletin No. 5, Jan. 11, 1939, but on or before the 1st day of the month the U. S. Treasury Finance Office of the Military Attaché, London, U. K., under No. 11, 1939.
- IV. Issuing Power--
  - a. The right to issue is reserved to the U. S. Treasury Dept., and the U. S. Army, Navy, and Air Corps. This right will be exercised by the U. S. Army.
  - b. Upon arrival at destination in foreign countries, the payee, when other arrangements are made, should contact the Central Cash Office of the Treasury Dept., at Washington, D. C., for future funds.
- V. Custody of financial books--
  - a. Original Vouchers & Receipts are sent monthly to the Cash Office of its Branch, G. 271.
  - b. A file to Vouchers & Receipts are sent monthly to the account of its Branch, G. 271.
- VI. Transfer of foreign currency or other for loan countries to the Central Cash Office, G. 271. This is also required that five, until such time as further instructions are received at destination.
- VII. U. S. Army & Navy Force--
  - a. Finance Branch Force-- distribution of G Bulletin, GPO 520.
  - b. Distribution of G Bulletin, GPO 520, Finance Bulletin (G), and other official publications that are required to be distributed to all personnel on G applications, GPO 520.
  - c. Distribution of office supplies to be secured from G. 271, if not available with our own stock.

Comments of Q M, Capt Steman on  
P.C.C. plan

The Q M P.C.C. Supply Plan is  
satisfactory and does not conflict with our  
plan.

This information has been forwarded  
to be kept together with the following  
suggestions of equipmenting procedure.

Rations - to be supplied monthly  
on basis of strength returns

Food and Cleaning and Laundry  
supplies - to be supplied monthly  
on basis of strength returns  
and P.C.C. Tables.

Q M and IT - to be equipted  
as required

SECRET

AUTH: *AD*  
DATE: *1/14*SUBJECT: Engineer Plan, ~~Project~~ Project

1. This plan is based on information available to Engineer this date. It is subject to change as additional information and military situation dictates.

2. General plan includes the following activities and considerations:

- a. Report to and conference with project C.P.
- b. Reconnaissance
- c. Estimate
- d. Detail plans
- e. Construction
- f. Maintenance
- g. Continuity of operations and future planning

3. a. It is assumed three stations have been selected with project administrative office at Moscow and field headquarters at drome near Poltava. Other two dromes forward of Poltava.

b. Detailed reconnaissance to be made of above four stations to determine facilities available and additional facilities needed.

c. Detailed estimate of supplies, materials, men (troop write) and equipment available and required to bring four stations in operational condition as soon as possible.

d. Detailed plans formulated on priorities established and men, materials and equipment allocated and distributed as needed.

e. Construction of the following items to be expedited in order of priority as listed:

- (1) Runways and extensions to same (one 6000' x 150')
- (2) Taxi strip to permit access to hard stands, 90' wide
- (3) A total of at least 40 hard standings to base heavy bombers
- (4) Servicing and maintenance installations
- (5) Housing accommodations for \* - 400 each drome, and an additional 400 (fighter crews) total 800 each, including water supply and sanitation
- (6) Sick bay or infirmary (24 beds each drome)
- (7) Completion of drainage facilities, access roads, and communications
- (8) Completion of technical facilities including open and covered storage for all supplies (see Annex "C")

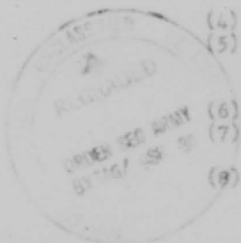

SECRET

- 1 -

0 2 8 7



SECRET

f. Allocation and supervision of men, equipment, and materials for maintenance, principally of runways, taxiways, hard standings, and communications.

g. Continual liaison with Higher USA Hq. STA FF and appropriate staff of Ally, for planning purposes and estimating future operations.

4. Engineer Supply:

a. (1) Attached hereto and marked Annex "A" is a list of all supplies and materials being shipped by convoy (Northern Route) to Murmansk or Archangel. (Including 12,000 tons of pierced steel plank and firefighting equipment)

(2) Continual liaison with Ally and higher U.S. echelons and appropriate port and transportation authorities to facilitate and expedite delivery and proper distribution of materials and supplies comprising above shipment.

b. Attached hereto marked Annex "B" is list of Engineer supplies available in P.G.C. for maintenance. These items will be kept at 60-day level for requisition.

c. Attached hereto marked Annex "C" is a list of certain Engineer shortages necessary to the project. Efforts are being made to obtain these from P.G.C.

d. Contacts with Ally will be instant and continuous for the procurement and use of such Engineer construction materials, supplies and equipment as are needed and are available. Requisitions for necessary Engineer items not available will be immediately placed with the appropriate U.S. agency.

e. Effort will be made to maintain a 45-day level of Engineer supply at each station or at a centrally located depot.

5. Engineer Personnel (Troop Units):

a. Attached hereto and marked Annex "D" is list of U.S. Engineer personnel assigned to the project. The group, as such, will exercise under the project C.O. such Engineer administrative, staff and liaison functions as are appropriate. They are also organized into three operational groups for liaison and technical supervision and advice, in the construction, rehabilitation and maintenance of the three field stations.

b. Personnel (Troop Units) required for actual surveying, construction and maintenance of all ground facilities at the stations or sites selected will be furnished by our Ally. It is estimated the following will be needed:

SECRET

- 2 -

0 2 8 8

SECRET

(1) Three (3) units comparable in strength, organization, and equipment with our Engineer Aviation Battalion.

(2) Three (3) units comparable, as indicated, with our Engineer Dump Truck Company.

(3) One (1) unit, comparable as indicated, to one Engineer Depot Company.

c. It is contemplated that all troop units, other than U.S. combat crews, will be available for employment on housing facilities, messing and other housekeeping work.

6. General:

a. To make such other reconnaissance, plans, and Engineer recommendations from time to time, as may effect and further the success of the mission.

b. This plan to become effective from the date of approval by the Commanding Officer of the Project.

Submitted by:

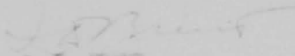
  
I. D. HUNT  
Colonel, CG  
Avn. Engr.

APPROVE:

Colonel, AC, USA  
Commanding

Date: \_\_\_\_\_ 1944

SECRET

- 3 -

0 2 8 9

1. There are 100 tractors, and 1000000 of the equipment should be used, the number of tractors used at each station should be listed, plus the value of the equipment to be used. (Note: A check should be made to see if the equipment is available at each of the stations, additional twenty-four heads per station are requisitioned from P.S.C.)
2. There are 100 tractors, and 1000000 of the equipment should be used, the number of tractors used at each station should be listed, plus the value of the equipment to be used. (Note: A check should be made to see if the equipment is available at each of the stations, additional twenty-four heads per station are requisitioned from P.S.C.)
3. There are 100 tractors, and 1000000 of the equipment should be used, the number of tractors used at each station should be listed, plus the value of the equipment to be used. (Note: A check should be made to see if the equipment is available at each of the stations, additional twenty-four heads per station are requisitioned from P.S.C.)
4. There are 100 tractors, and 1000000 of the equipment should be used, the number of tractors used at each station should be listed, plus the value of the equipment to be used. (Note: A check should be made to see if the equipment is available at each of the stations, additional twenty-four heads per station are requisitioned from P.S.C.)
5. There are 100 tractors, and 1000000 of the equipment should be used, the number of tractors used at each station should be listed, plus the value of the equipment to be used. (Note: A check should be made to see if the equipment is available at each of the stations, additional twenty-four heads per station are requisitioned from P.S.C.)
6. There are 100 tractors, and 1000000 of the equipment should be used, the number of tractors used at each station should be listed, plus the value of the equipment to be used. (Note: A check should be made to see if the equipment is available at each of the stations, additional twenty-four heads per station are requisitioned from P.S.C.)
7. There are 100 tractors, and 1000000 of the equipment should be used, the number of tractors used at each station should be listed, plus the value of the equipment to be used. (Note: A check should be made to see if the equipment is available at each of the stations, additional twenty-four heads per station are requisitioned from P.S.C.)
8. There are 100 tractors, and 1000000 of the equipment should be used, the number of tractors used at each station should be listed, plus the value of the equipment to be used. (Note: A check should be made to see if the equipment is available at each of the stations, additional twenty-four heads per station are requisitioned from P.S.C.)
9. There are 100 tractors, and 1000000 of the equipment should be used, the number of tractors used at each station should be listed, plus the value of the equipment to be used. (Note: A check should be made to see if the equipment is available at each of the stations, additional twenty-four heads per station are requisitioned from P.S.C.)
10. There are 100 tractors, and 1000000 of the equipment should be used, the number of tractors used at each station should be listed, plus the value of the equipment to be used. (Note: A check should be made to see if the equipment is available at each of the stations, additional twenty-four heads per station are requisitioned from P.S.C.)

1. . . . .

... 1st Lt. ...  
/ 1st Lt. ...  
1st Lt. ...  
(...)

... 1st Lt. ...  
/ 1st Lt. ...  
1st Lt. ...  
(...)

... 1st Lt. ...  
/ 1st Lt. ...  
1st Lt. ...  
(...)

... 1st Lt. ...  
/ 1st Lt. ...  
1st Lt. ...  
(...)

... 1st Lt. ...

1st Lt. ...  
Col. ...

0 2 9 1







CONFIDENTIAL

(Classification)

3 ENCLOSURES

COPY NO. (For Special Section only)

MILITARY INTELLIGENCE DIVISION W. D. G. S.

MILITARY ATTACHÉ REPORT M.A.A.R.

(Country reported on)

Subject Inspection of Kharkov and Poltava Airdromes. I. G. No. 9185

(Brief Descriptive Title)

From M. A. Moscow Report No. 2555 Date 3 April 1944

Source and degree of reliability:

Source: Personal inspection.

SUMMARY. Here enter careful summary of report, containing substance succinctly stated; include important facts, names, places, dates, etc.

A report of an inspection of the airdromes at Kharkov and Poltava.

CONFIDENTIAL  
BY 1000 3 R 30

MIS - 2 copies; file - 2 copies.

Distribution by originator

Heading space below for use in M. I. D. The section indicating the distribution will place a check mark in the lower part of the recipients' box in case one copy only is to go to him, or will indicate the number of copies in case more than one should be sent. The message center of the Intelligence Branch will draw a circle around the box of the recipient to which the particular copy is to go.

|                             |           |         |         |           |                |       |        |           |               |                |                  |                     |                   |      |
|-----------------------------|-----------|---------|---------|-----------|----------------|-------|--------|-----------|---------------|----------------|------------------|---------------------|-------------------|------|
| OHQ                         | G-1       | G-2     | G-4     | WPD       | ONI            | State | Comms  | Treas.    | F. B. I.      | A. W. C.       | C. & G.<br>S. S. | Int. Coll.          | Expert<br>Control |      |
| A. C. of S.<br>G-7          | Chas. ID. | MA Sec. | FL Sec. | Rec. Sec. | Trans.<br>Sec. | CID   | RRG    | P. and T. | Inf.<br>Cont. | Coord.<br>Sec. |                  | Inf.<br>Ad.<br>Div. | Coord.<br>of Inf. |      |
| AR                          | BE        | CE      | DE      | EE        | WE             | FE    | LA     | SI        | Cont.         | Dissem.        | Field<br>Per.    | ASW                 | USW               | ARWA |
| CHIEFS OF ARMS AND SERVICES |           |         |         |           |                |       |        |           |               |                |                  |                     |                   |      |
| Inf.                        | Org.      | FA      | CAC     | AC        | AAF            | Sq.   | Arm'd. | Ord.      | QM            | CWE            | Med.             | Engr.               | Fin.              |      |
| ATTN: M.                    | CG P&I    | CG P&I  | CG P&I  | CG P&I    |                |       |        |           |               |                |                  |                     |                   |      |

Enclosures:

CONFIDENTIAL

(Classification)

Members of the Party.Americans

Brigadier General W. B. Crist  
 Colonel A. Kessler  
 Colonel Paul F. Sullivan  
 Colonel Charlie K. Bond, Jr.  
 Captain Henry W. Ware

Russians

Major Andrei Savelievich Solotnikov, Operations.  
 Major Vasilii Efimovich Kharkov, Airdrome Engineer.  
 Major Arnold Isaslavich Smoliarov, Technical Interpreter.  
 Major Aleksai Ivanovich Kurkin, Supply.

Russians Dealt With on Trip.

Major General Piatikhin, C.O. of Kharkov area of aviation.  
 Colonel Boroshenko, assistant to General Piatikhin.  
 Lt. Colonel Malinovski, C.O. of Kharkov airdrome.  
 Colonel Ormakov, C.O. of Poltava airdrome.

Date of Inspection.

8 - 9 March, 1944.

The Americans met the Russian party at Central Airdrome, Moscow, about noon. Major Solotnikov was in charge of the tour, and Major Smoliarov and Captain Ware acted as interpreters. For several days the trip had been postponed due to inclement weather. The hard-rolled snow on Central airdrome was firm enough to taxi across, and the runway was cleared of snow.

Our aircraft was an American-made DC-3 (in fact, it was an ex-airline ship of some commercial airline in the United States for it still had the familiar color scheme and English written nomenclature all about it) with Russian engines. This engine is similar to the American-made Wright engine, but it develops about 850 - 850 h.p. for take-off. It is easy for a flyer to distinguish the difference in power output of Russian mounted engines from that of American mounted engines in the DC-3 type aircraft.

Cruising at about 8,000 feet altitude, and generally following the railroad, the trip was made from Moscow to Kharkov in two hours and fifty minutes.

It was interesting to note that the amount of snow on the ground gradually changed from solid and heavy coverage in the Moscow region to none just south of the Orel region. The muddy condition of all roads in the Kharkov region and for a hundred miles to the north of Kharkov was very apparent, even from the air. From a point a few miles south of Moscow, along our flight

From U. S. Military Mission, Moscow No. 2858 3 April 44

route, along our flight route, to Kharkov, we could see all types of prepared defensive positions and results of battle. Many 3-position and 4-position gun emplacements were noted as well as many very irregular trenches. The longer trenches had, at irregular intervals, short communication trenches running off into lower depressions generally in an easterly direction. (The exact location of most of the observations is impossible to determine.) Gun emplacements indicated the use of straight-line, triangular, and almost square deployment. On one occasion an anti-tank fence, of what appeared to be steel rails or heavy logs stuck upright in the ground, followed a small stream bank from one side of our flight path to the other, as far as I could see. It consisted of three fences of closely spaced uprights. The three fences were exactly parallel and an estimated distance of 16 to 20 feet apart. About the upper slopes of much of the rolling terrain the ground had been dug out in such a way that a tank would be allowed to move into it and have only its turret protruding above the hulled-out revetment.

During the flight, we passed over many small villages and a few large towns. The pilot flew so wide of Yula, Orel, and Kursk, that we barely saw the smoke of the city factories, much less the cities proper.

An airdrome with snow-cleared concrete runways near the town of Derpukhov was noted. The runway was approximately 3,000 feet long, and a very short perpendicular taxiway jutted off the east end for a few hundred feet. Many fighters of the YAK model were parked about the field. One hangar was seen.

Our aircraft flew over the city of Kharkov from the north to the south. Just within the northern suburbs is an airdrome (see Annex #1) without runways that extends an estimated 3,500 - 4,000 feet in a SW - NE direction.

There were many Red Air Force fighter aircraft that appeared to be of the YAK model. There were a number of buildings along the northwest edge of the field. They may have been training planes. A Russian officer stated that the airdrome was heavy with traffic, and training of pilots was in progress there. A flight of 6 training aircraft was seen a few miles to the starboard as they approached the field.

Although the railroad had been followed from Moscow to Kharkov during most of the flight, only one train was seen. It consisted of a locomotive and a caboose moving north. It was noted that this railway at one time was a double line but there remained only one track. Nothing was seen of rails or ties of the missing line. The railroad yards in SW Kharkov were full of rolling stock, and most of it was damaged beyond use. There were two or three trains, however, that consisted of about 15 to 30 cars each. In one train was a dozen flat-cars, each loaded with light green-colored fuselages and wings of fighter aircraft. They were either YAK or LA-6 type fighters. On each flat car was a completely assembled wing and a completely assembled fuselage. The wing was lashed to the flat car, resting on its leading edge, and parallel to the fuselage.

From U. S. Military Mission, Moscow No. 2655 3 April 44

The city of Kharkov was badly demolished by mines left by the retreating Germans. Our flight carried us over the southeast edge of the city to the main airdrome. (See Annex #2). Landing clearance was given by green rocket. The black soil was a gummy mud, and a STORMOVIK with a blown tire was wired in it off the side of the runway. About the field were parked several DC-3's, a couple of Russian medium bombers - one with the engines dismounted, several YAKS - probably the YAK-9, a few STORMOVIKS, and 6 or 8 P-40s Lend-Lease aircraft.

Kharkov airdrome #1 serves as an aircraft ferry point and a station of the Civil Air Fleet for transport supply purposes. There probably are no operational missions scheduled from this airdrome, however. The general building area, which remains as a general locale of debris and a scientific masterpiece of German demolition work, is on the south edge of the field. That was a medium-sized hangar (estimated to be 150 x 150 feet) is now a pile of mortar and brick, marked by twisted and rusty steel girders and frame-work. The administration building is leveled to the ground. All buildings on the field were left useless. A few make-shift shacks were in use by the Red Air Force, and oil and gasoline was stored in tanks that resembled boilers of all shapes and forms. They were not dispersed, nor were there any signs of any attempt to put them beneath the ground. Heavier attempts at camouflage consisted of paint splotches of white and green on all of the tanks and rope netting on two or three of the smaller sized ones. A bomb dump was located about 200 yards off the end of the NW/SE runway. The various revetments dispersed about the field consisted of log and earth construction. Each revetment was built in such manner as to protect an aircraft from only two sides. Two parallel walls, varying in height from 8 to 10 feet, were about 50 feet long and approximately four feet thick. Each wall was built similar to a log cabin and the enclosed span was filled with earth. Some of the walls were strengthened by log supports as props - from the outside only, however. Pathways of brick or concrete led to the various revetments. Some parking hard stands did not have the protective walls about them.

Lt. Colonel Malinowski met us at the airdrome and immediately drove us into the city. Two vehicles were used. One was a ZIS (The Russian automobile that resembles the American Buick so closely), and the other was a Ford. As usual, the vehicles showed evidence of extensive use and poor maintenance.

By road - and a poorly maintained one at that - it is about six or eight miles to the pavement of the suburban streets of Kharkov. Almost every large sized building in the city is either gutted, partly demolished, or scarred and cracked by either bombs, mines, or shells. Generally speaking,

From U. S. Military Mission, Moscow No. 2655 3 April 44

the city is not nearly so destroyed as Stalingrad, but is slightly more damaged than Leningrad. German demolition work is extensive and thorough. Many buildings are posted with signs, which read: "This building is not mined."

The people of Kharkov seem not far removed from those of Moscow in spirit and atmosphere. Possibly they are not dressed so well. They were greatly curious about the foreign Americans and showed no efforts to conceal it. Our quarters were said to be a third-rate hotel; the main hotel had been damaged beyond use. Rooms were reasonably clean, but the public latrine down the hall was inexcusably filthy and emitted a nauseating stench. The single beds were in poor condition, but the linen and blankets were spotless. The water system in the hotel did not function, and the electricity was used sparingly.

Lunch consisted of the usual vodka, caviar, and salads of fish. Egg omelet was the main course.

While inspecting Kharkov No. 2 airbase, it was decided that the runways could not be extended any further than 500 to 600 feet. Too, it was questionable as to whether the 12-centimeter concrete blocks would withstand the weight of a 65,000 pound B-17. The base for the concrete runway is a 18-centimeter (8.9") layer of sand. The Russian airbase engineer would not commit himself when questioned about the strength of the surface. The Russian Lieutenant Colonel said he thought the field would be dry enough to use the general landing area during the months from May to October. Housing was practically non-existent. Major Smolinov, however, stated there would be no difficulty in finding housing in the city.

During the evening the Commanding General of the Red Air Forces in the Kharkov area was introduced to us, and he was cordial and warm in his conversation. The conversation consisted more or less of small talk, but it was obvious from opinions of some of the Russian colonels that the Soviets thought the Japanese to be a "vile people" and the U.S.S.R. would eventually go to war with them - but not until the Germans were beaten. The usual Red Army pride and confidence was very apparent throughout the evening. One Russian colonel, who talked with Captain Bare, our interpreter, constantly spoke of Russian girls and made sexually shaded jokes.

The following morning the flight to Poltava took place. The trip lasted 30 minutes and was comfortable and extremely interesting. Not one single moment of the whole flight can be recalled but at such time bomb craters, shell holes, trenches, gun emplacements now vacated, or some form of the retreating Germans scorched earth demolition work could be observed. One train with many types of mechanized vehicles traveling towards Poltava from Kharkov was noted. The small villages and inhabited localities revealed destruction at every point. It seems to be a policy of the Germans to destroy all buildings in the villages and even about the countryside. The only buildings or structures that were not bothered by the retreating enemy were the homes about the countryside with their outhouses nearby and the small homes of wooden structure in the villages. The results of fire and demolition was present every 100 feet or so in every inhabited place over which our flight and path crossed.

From U. S. Military Mission, Moscow No. 2866 3 April 44

It was impossible to get a good view of the city of Poltava proper, but it is believed that it had suffered equally as much as Kharkov. The field at Poltava (See Annex #3) is located about 2 miles west of the city, and a railroad skirts its southwest edge. The runway construction is similar to that of Kharkov, but the E/W runway could easily be extended about 2,500 feet. The same black, loamy, mud was even more evident than at Kharkov. A large apartment building, partly demolished, yet housing many Red Air Force Officers, women, and men, offers a dangerous obstacle for landing aircraft. It is about 90 feet high and approximately 2,000 feet off the south end of the E/W runway.

The E/W runway was being used as a parking area, and several DC-3 aircraft were parked here. Colonel Brnakov met us at the plane and immediately offered his services to help us in our inspection of the field.

Here again, as at Kharkov, were demolished airdrome buildings and a double hangar which had been at least 150 x 200 feet. At least 70 to 80 aircraft were dispersed about the edges of the field, and amongst the YAKS, STORMOVIKS and trainer-type Russian bi-planes were a few A-20's, one B-25, a P-39, and 2 Hurricanes. This airdrome is about 100 miles from the front and is used as a rearward tactical base. A YAK-type fighter was propped up in a flying attitude with several men working about it. They were firing the guns into a butt about 250 yards away. Another YAK took off on what was obviously a test flight, for the pilot flew around the field at an altitude of about 3,000 feet executing normal turns and then came in for a landing after 15 or 20 minutes. On another occasion a flight of four YAKS took off and flew out of sight to the West. All Lend-Lease American aircraft were tightly cowled with engine covers and dispersed towards the southwest corner of the field. There were several revetments about the field, but they were not as carefully constructed as the ones at Kharkov. The revetments consisted of levees of earth about 6 to 8 feet high. Some were U-shaped, while others were the two-parallel-wall type.

Several YAKS with bent propeller tips were noted---evidently resulting from nose-up accidents in the mud. No maintenance facilities were seen. A few combat crews rested beneath the wings of their PE-2 dive bombers. Small rocket-type bombs---about 2 feet long---were mounted in shackles on the underside of the wings of these aircraft. They were seen at a distance but not observed closely.

Some blue, bomb-shaped cannisters that hung beneath the lower wing panels of some of the small bi-plane trainer-type aircraft attracted our attention. The can is about 4 feet long and possibly a foot in diameter. The conical shaped nose is hinged to open outward, leaving a recess in which is carried mail or other administrative papers. (This aircraft is the type that was used so effectively to drop bombs during moonlight nights in the battle of Stalingrad.)

From U. S. Military Mission, Moscow

No. 2555

3 April 44

0 2 9 9



Upon finishing the inspection, another typical Russian meal was served in the large apartment building to the south of the field. While going upstairs inside the building, several German words written across the upper part of the door frames were noted. A picture of a German dive bomber with German captions adorned the wall near the main entrance of the building. The German Air Force had its headquarters here when the enemy occupied the airdrome.

During lunch the weather for the Moscow flight was obtained by telephone from Kharkov. It was doubtful but good enough to slip into Moscow from Poltava.

Our party took off and flew at an altitude of about 1,000 feet ---sometimes as low as 500 feet---all the way to Moscow. During the flight two or three airdromes on which fighters were parked wingtip to wingtip and tightly covered with engine covers were noted. Snow covered the ground as well as the aircraft. These airdromes are estimated to be in an area on the course from Poltava to Moscow about 200 miles north of Poltava.

During the flight, Major Scolliarov told us that the Red Air Force has attached to airdrome units certain specialists whose duties and functions were the disposal of enemy dud bombs.

Landing was made at Central Airdrome, Moscow, after a pleasant flight through light snow and rain---3 hours and 15 minutes. While taxiing to the parking place a wheel became lodged in a hole off the edge of the taxiway. The snow and ice had to be cleared from the path of the wheel before moving the A/C further.

During the tour the members of the Russian party and those whom we met at Kharkov and Poltava were most cooperative and courteous.

#### COMMENTS

(1) In that region of the U.S.S.R. between Moscow and Kharkov there are many airdromes and landing grounds---though the majority are not too elaborately prepared.

(2) Intensive pilot training is carried on at Kharkov Airdrome. It may embrace advanced fighter training.

(3) The annual thaw of the frozen ground in the region south of the latitude of Orel has set in much earlier this year, and the Red Air Force is having its troubles with muddy fields.

(4) The turf of landing grounds in the Kharkov region will be unfit for use by medium sized A/C until the latter part of April.

(5) The Germans retreated from Kharkov, leaving a path of destruction. "Scorched earth" in every sense of the word is the policy of the retreating Germans.

From U. S. Military Mission, Moscow

No. 2535

3 April 44

-7-

0 2 9 7  
0 3 0 0

(6) The Soviet Red Air Force appreciates the value of A/C revetments and dispersal in achieving airdrome security.

(7) The majority of destruction in the city of Kharkov was accomplished by German mines.

(8) Soviet Airdrome Engineers do not visualize the need of hard-surfaced runways of a length greater than 1200 M. (3900 Ft.). Concrete, hexagonally-shaped blocks, 12 CM. (4.7 in.) thick and about 4 ft. in diameter, is standard construction material for runways.

(9) German Demolition work on airdromes, which are evacuated, is thorough and complete.

(10) Housing and public utilities at Kharkov and Poltava are inadequate for the needs of the population.

(11) It is questionable as to whether standard built Red Air Force runways will withstand the weight of heavily-laden USAF MB.

(12) Runway extension possibilities at Kharkov and Poltava airdromes are greatly limited without major engineering work.

(13) The "work-horse" A/C of the Red Air Force are YAK Fighters, STORMOVIKS, and PS-2 dive bombers.

(14) Reconstruction work of war-torn Russia that would have no direct bearing on the war effort is not considered essential until Germany is defeated.

(15) American Lend-Lease B-25's, A-20's, P-40's and P-39's are used on the Ukrainian front.

From U. S. Military Mission, Moscow No. 2666 3 April 1944

-6-

0 2 9 0  
1 3 0 1

ANNEX NO 1

KHARKOV AIRBORNE NO 2 (draw fr memory)



0302

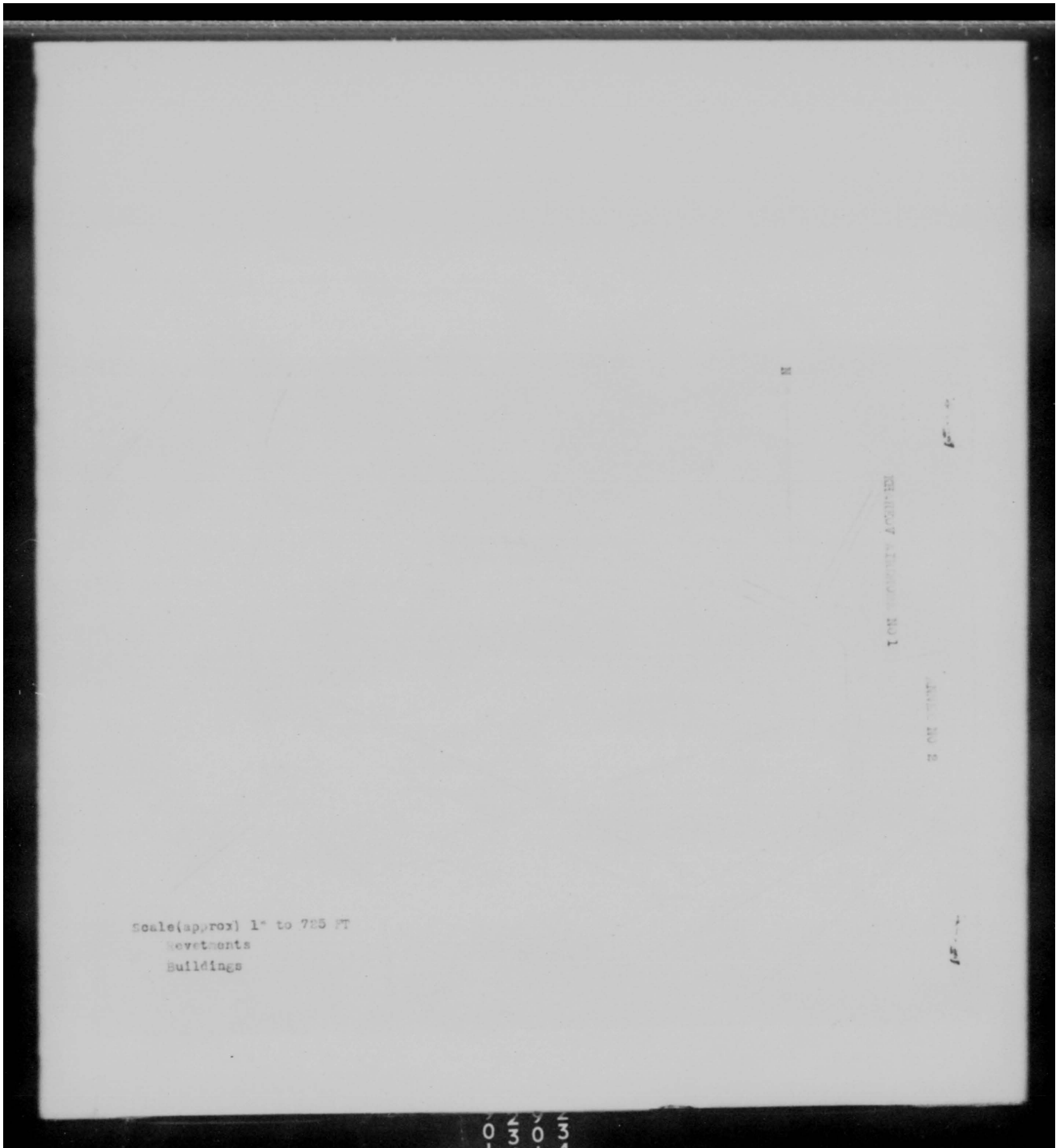

Scale (approx) 1" to 725 FT  
Revetments  
Buildings

0303

ANNEX No 3

POLTAVA

N

Hgr - destroyed

Bldg

railroad

(note: This sketch is made from memory)

Scale: (approx) 1" to 1250 Ft

0 3 0 4

Notes for meeting with General Nikitin --- 3 Apr 1944

MAJOR QUESTIONS:

1. Dates when staff should move to Poltava.
2. Headquarters and living requirements for American Headquarters at Poltava (see attached notes).
3. Date on which initial personnel and supplies to be sent from Teheran to Poltava.
4. Final arrangements for Colonel Griffith's command plane to come in and Colonel Brent and Lt. Colonel Day required and visas for crew.
5. Final arrangements for use of U.S. Aircraft to move key personnel and supplies from Teheran to Poltava, including Soviet radio operators and navigators.
6. Date when telephone lines between the three bases will be installed.
7. Information required on the condition of roads between the three bases.
8. Local transportation between Poltava and base and between the three bases pending arrival of our own transportation. Particular need for local transportation for Signal and Engineering personnel.
9. When can railroad tracks be repaired at Poltava?
10. Photographs of the three fields.
11. Date when dispersed track at Poltava ready.
12. When can additional staff conferences be arranged - especially Ordnance and Chemical Warfare?

ADDITIONAL QUESTIONS:

1. Obtain organization chart of Russian set-up and personnel.
2. Can Russians make translators and interpreters available from start?
3. Letter has been forwarded on frequencies. When may we expect answer?
4. Repeat Colonel Kessler's requirements for type of radio navigational facilities.
5. Repeat request for target folder data as Colonel Kessler would like to take this with him when he returns.
6. Mail provisions, if mentioned, call attention to no censorship of mail for Soviet personnel stationed at Fairbanks, Alaska.
7. 2000 gallons gasoline 100 octane, 36 gallons S.A.C. oil 1120 grade for each C-87 at Poltava required.



7. (a)if C-47 300 Gal. Gas. Baku )  
400 Gal. Gas. Stalingrad )  
600 Gal. Gas. Poltava )...10 Gal. Oil at each stop  
500 Gal. Gas. Stalingrad )  
300 Gal. Gas. Baku )

(b) C-47 Non-stop 1250 Gal. Gas. at Poltava, 20 Gal. Oil.

8. Can 8 American Red Cross girls come in under group visa system?

HEADQUARTERS REQUIREMENTS

Colonel Griffith will require the following for headquarters and central base depot personnel, that is for all personnel other than those assigned to the three bases:

1. Billeting space in town initially for thirty (30) staff officers; if possible can later move out to the base.
2. 5200 square feet (483 square meters) for office space for these staff officers, the twenty-five (25) enlisted men working with them at the headquarters, and the five (5) Russian liaison personnel which it is requested be directly attached to the American headquarters.
3. It is intended to house at the base twenty-five (25) enlisted men plus the fifty-eight (58) additional weather and supply and signal enlisted men (or a total of 75 enlisted men), and ~~one~~ <sup>one</sup> ~~ten~~ (10) weather and supply and signal officers.
4. At the bases the central signal and cryptographic section will require 800 square feet (74 square meters).
5. 120,000 square feet (11,148 square meters) of storage space at the base will be required for all classes of supplies.
6. Raise question of immediate clearance for Colonel Brent and Lt. Colonel Day. Both have passports but no visas and group visa system will not be authorized before April 6th or 7th.
7. First detachment to arrive Poltava will include ten (10) officers and 1 enlisted man (if Colonels Brent and Day enter before move to Poltava it will consist of twelve (12) officers and one (1) enlisted man). This will include: Colonel Griffith, Lt. Colonel Jackson, Major Lepawsky, Major Richard, Major Spaulding, Major Frank, Captain Coleman, Captain Glick, Captain Boggs, Lt. Wagner and T/Sgt. MacFarland.
8. Will we be able to move either Colonel Griffith's plane or hospital plane from Poltava to Teheran in case of the necessity for an emergency evacuation?

March 17, 1944

MOST SECRET

SECRET

My dear Mr. Molotov:

The arrangements regarding the shuttle-bombing project are developing with great rapidity. I feel that I could be reviled if I failed to tell you how much I appreciate the cooperation given us by the Soviet authorities, and how the Red Air Staff has won our admiration by the manner in which it conducts its business.

In the course of the discussion between the Red Air Staff and General Leane, additional questions of policy have arisen which I have been informed require Foreign Office decision. These are as follows:

1/ AUTHORITY TO MOVE CERTAIN PERSONNEL AND FREIGHT FROM TEHRAN TO POLTAVA BY U. S. AIRCRAFT.

Two hundred fifty United States personnel and all communications equipment are to be moved from England to Teheran by air in about thirty airplanes arriving successively over a period of several weeks. This movement, as far as Teheran, is to start at the end of this week. The personnel includes those necessary for the installation of communications equipment and also airplane construction engineers. The freight, which weighs about 41,000 kilograms, is almost exclusively communications equipment which is the first installation to be made. It is requested that authority be granted for these airplanes to proceed from Teheran to Poltava to deliver the personnel and freight, after which they shall return immediately to England via Teheran.

2/ DELIVERY OF EMERGENCY FREIGHT TO POLTAVA BY U. S. AIRCRAFT.

In operations of the magnitude envisaged, there will be many hurried emergency calls for spare parts or other equipment that have been omitted from sea shipments. To care for these contingencies it is requested that authorization be given to fly an average of one aircraft per week from England or Italy via Teheran to Poltava, commencing as soon as the work starts on the airfields selected. Once operations start, each of these aircraft would be retained at Poltava until the arrival of the first operational groups and then be used to evacuate wounded to our general hospital at Teheran. Personnel replacements for this operation could be transported by these aircraft.

3/ ADMINISTRATIVE AIRCRAFT FOR COLONEL GRIFFITH:

As commander of the U. S. personnel on the three air bases, Colonel Griffith will have many administrative matters requiring him or members of his staff to go and to transport emergency supplies from one field to another and occasionally from his headquarters in Poltava to Moscow. For this purpose, authority is requested to have one C-47 U. S. aircraft stationed at Poltava. This can be operated by Soviet personnel if desired, but it should be at Colonel Griffith's disposition at all times, and he should be allowed appropriate freedom of movement as to its use for the

-1-  
SECRET

SECURITY CLASSIFICATION  
 REVIEWED 10/21/82 BY  
 BY 282 P24 25 H 30

0308

stated above.

SECRET

These requests are submitted to you with the understanding that the privileges requested will be used exclusively as aids to the success of the shuttle bombing project and for no other purposes. The aircraft involved will, of course, operate under any regulations prescribed by Soviet authorities.

I will be grateful if you will give these matters your consideration and inform me of your decisions.

Sincerely yours,

(sgd) S. A. Harrison

-2-

SECRET

0309

SECRET

U.S.S. Meeting, 16 March 1944

Present: Colonel Cullen, Lieut. Colonel Makarov, Major Smoliarov,  
Captain Erhov, Captain Ware

PHOTO-RECONNAISSANCE

Colonel Makarov and Major Smoliarov indicated that all questions of policy concerning this work would have to be worked out elsewhere, and then the decisions would come down through the High Command. It was pointed out, however, that everything essential to the successful carrying-out of these operations would be worked out.

Colonel Makarov said that, therefore, he could not give definite answers to the following questions raised:

- 1) to what extent the Red Army Air Force is interested in receiving information on the results of American photo-reconnaissance missions,
- 2) whether or not the Red Army Air Force plans to ask us to take photographs for them of certain areas,
- 3) whether the desired Russian photo-intelligence material can be made available to the American photo-specialists working on this project in Russia.

Colonel Makarov said that it was his opinion that the Russians would be very interested in having pictures taken by the American reconnaissance, and that he thought that one print of each photograph should be adequate.

Colonel Makarov felt confident that if the Russians have photo-intelligence or other material of value in studying the targets we are interested in, that this material will be made available to us. The question of having the Russians designate an officer to carry on this work with the American specialists at the field used by U.S. in Russia --- instructions on this will come from the high command.

Colonel Cullen explained that in U.S. practice, sometimes there are two individuals assigned, one capable of handling the operational (in flight), and the other the technical aspects of the photographic work.

Colonel Cullen said that as soon as possible he would like to see, if possible together with Colonel Makarov, the Soviet photo-reconnaissance apparatus and equipment, and he would like to see what is done in photo-analysis. While this request would have to be worked out higher up, since it involved a matter of principle, Major Smoliarov said that in any case it would do no harm in addition, to have Colonel Cullen write a letter.

-1-

SECURITY CLASSIFICATION  
REVISED 1988, 1993, 1994  
BY 140-100-000-30

SECRET

0310

SECRET

(O.V.S. Meeting, 16 March 1944--Continued)

Major Smoliarov said that concerning Kharkov and Poltava General Nikitin had given the order to have given to us the photographs asked.

Colonel Markov said that the Soviets do have photographs on all their advanced fields, and that he assumed that after the fields to be used by U.S. were decided upon, pictures for purposes of field identification would be made available. Major Smoliarov indicated that this general question would probably be decided at the special meeting of General Nikitin and the American Colonels, to be held tomorrow.

Colonel Makarov said that the Soviets do have the data which is used in forecasting airophotography weather. After the policy questions are indicated worked out, and the actual work develops, he indicated, may questions on the use of Soviet materials and information can be worked out on the spot.

From the discussion on technical points, the following was established:

1. The Soviets are acquainted with our type of cameras.
2. Soviet reconnaissance planes have taken photographs from the high altitudes which we use.
3. The 13 enlisted men Col Cullen expects to have at his disposal who is adequate to handle our own processing, without soviet help.
4. In view of the fact that the Soviet developer tanks used will accommodate not over 30 meters of film, which would necessitate cutting our 100 foot film rolls in half, it is desired to bring our own simple construction 50 lb. developing tank.
5. We will plan to bring enough paper to make our own prints.
6. The Russians do have chemicals which they have used in developing American films. They are acquainted with the Class A and the Class L U.S. films, but they have not used the even faster night-use film.
7. The Russians can handle the making of the U.S. small prints, but their 30 by 40 centimeter frames will not handle our large 9 by eighteen inch prints.
8. Regarding the possibility of getting enlargements from our 9 by 9 inch, the Russians have discontinued the practice of enlarging this work.
9. Film drying is done with the use of alcohol and drying barrels, where no heat is used.
10. The Soviets dry their prints in automatic machines, with heat.
11. The air base to be used may be equipped with 110 v. current. The Russian field-laboratories have their own power: 110 v.
12. An adequate supply of clean water should be available at the field decided upon.

-2-

SECRET

0311



Moscow, March 8, 1944

SECRET

My dear Mr. Molotov:

In connection with the shuttle bombing and reconnaissance recently approved by Marshal Stalin, I am happy to inform you that since the arrival of General Spaatz' representatives from London satisfactory conferences have been held with representatives of the Red Air Staff in arranging for the necessary details for carrying out this project. We have met with the heartiest cooperation from the Red Air Force.

One matter which I understand is approved by the Red Air Staff but which requires the approval of the Foreign Office is the operation by the U.S. Air Force of radio communication necessary for the operation of our shuttle bomber forces and photo reconnaissance. It is apparent that differences in language, in procedure and in types of equipment necessitate that operation of communications required for the success of the activity must be with American personnel. We will undertake to abide by any regulations concerning communications that you wish to prescribe and will limit their use to the communication necessary for this particular undertaking.

It will be entirely satisfactory to us, if you so desire, for you to have Soviet personnel present at all times with our operating personnel and we shall gladly give them free access to all communications sent or received through the channels which we are allowed to operate.

May I ask that approval be granted promptly so that the details can be worked out without delay? General Deane has already advised the Red Air Staff of the requirements. The equipment is being assembled for delivery by air. If there is any further information you require, please let me know.

Agreements on other matters are being reached. A party of Soviet and American officers are now inspecting the air bases. Some five ships with needed supplies as agreed upon, including a tanker of 100 octane gasoline, are being loaded in England to proceed to North Russian ports with the next convoy.

Sincerely yours,

W.A. HARRIMAN

His Excellency,  
V.M. Molotov,  
People's Commissar for Foreign Affairs  
Moscow.

RECEIVED  
MAR 10 1944  
BY 100 PER 48 R 30

0312

SECRET 5 March 1944

His Excellency  
V.M. Molotov  
People's Commissar for Foreign Affairs  
Moscow

My dear Mr. Molotov:

In connection with the shuttle bombing project which was recently approved by Marshal Stalin I am happy to inform you that General Spaatz' representatives have come from London, and that the completion of the necessary details for carrying out this project are now underway.

We have met with nothing but the heartiest cooperation from the Red Air Force and I feel certain that the project will culminate in an achievement of which both our countries will be proud. I consider that aside from the operational value that is to be obtained there will be an extremely beneficial morale value throughout the United States in the knowledge that Soviet and American forces have actually joined in cooperative action.

There are two matters brought forth in the discussions which will require a decision by the highest Soviet authority. These are, first, the question of admitting American personnel needed for the operation and administration of this project to the Soviet Union without the formality of passports and visas. The second concerns control of the communications necessary for the operation and administration of our bomber forces.

With regard to the question of visas, there are now set up in London certain groups who should depart for the Soviet Union in the near future. These include first, a group of from 40 to 50 signal communications people who are now scheduled to leave by air on or about March 20. They will bring with them the equipment to be installed and the personnel to accomplish the installation. Another group is being assembled in England for early shipment by air which includes about 250 individuals whose duties are of such a specialized nature that they cannot be replaced by Soviet personnel. Ultimately about 2,000 individuals will be required for the ground operations on this project and as previously indicated we hope to limit the number of American personnel to those whose duties cannot be undertaken by Soviet personnel, however there will undoubtedly be a group of 400 to 500, in addition to the 250 mentioned above, who will eventually have to be sent to Russia. Finally, of course, there will be the members of the crews who are actually engaged on the bombing missions. These will amount to in the neighborhood of 1,000 to 1,200 on each mission. I think you will agree that for an operation of this magnitude, and one in which last minute changes will frequently be necessary, it would be impracticable to go through the formality of passports and visas for each individual on each occasion. I suggest, therefore, that a procedure be worked out which will be satisfactory to you whereby you may be kept continuously informed as to what personnel is involved

including names, movements, dates of arrival and departure, and any other information that you consider necessary. In view of the immence of the arrival of some of these groups I urgently request that you have the matter given early consideration.

As to operation of communications, I think it is apparent that differences in language, differences in procedure, and differences in types of equipment necessitate that the control of communications required for the success of these operations be with American personnel. Again we will undertake to abide by any regulations concerning communications that you wish to prescribe and we shall certainly limit their use to the communications necessary for this particular project. We can understand a natural desire on your part to be kept fully informed as to the communications in and out of this country. To this end it will be entirely satisfactory to us, if you so desire, for you to have Soviet personnel present at all times with our operating personnel and we shall be pleased to give them free access to all communications sent or received through the channels which we are allowed to operate.

Our people at home feel that the project cannot be a success unless something along these lines is worked out. May I ask that you also have this matter given early consideration.

Very sincerely yours,

W.A.H.

- 2 -

0314



0315



0316



0317





0 3 1 8

DECLASSIFIED  
EO 11652

FILE IN  
CLASSIFIED FILES

Box - #31

E.T.O.

Doc. file 312 filed in  
AF 1480

RETURN TO  
AFSHHC  
MAXWELL AFB AL 36112

519.815-1  
44/07/22

**SECRET**

5-993

DECLASSIFIED  
EO 11652

1029152

0319

~~SECRET~~

[REDACTED]

SECRET  
AUTHORITY  
DATE 101 22 1944  
INITIALS RSC

HEADQUARTERS  
UNITED STATES STRATEGIC AIR FORCES IN EUROPE  
Office of the Commanding General

DECLASSIFIED  
EO 11652

APC 633, U.S. Army

22 July 1944

SUBJECT: Plan for Retaliatory Gas Attack on Germany.

TO : Commanding General, Eastern Command, USSTAF, APC 798, U.S. Army.

1. The inclosed paper, above subject, is the product of a joint committee of the War Cabinet, including representatives of the Air Ministry, USSTAF, SHAEF, and Ministry of Economic Warfare.

2. It is suggested that you give close study to this material as it is expected that detailed plans for the use of gas against Germany may soon be required of all United States Air Force Commands in this theater by Supreme Headquarters Allied Expeditionary Forces.

By command of Lieutenant General SPANDE:

*H. S. Bernard*  
H. S. BERNARD,  
Capt, AGD,  
Asst. Adj. Gen.

1 Incl: Plan for Retaliatory Gas Attack on Germany

519.815-1  
44/07/22  
RETURN TO  
AFSHHC  
MAXWELL AIR FT. 2812

CLASSIFICATION CHANGED TO SECRET  
EEO DIR 13000, 27 SEP 88

NAME  
DATE

[REDACTED]

1029152

5

(Doc. 5)

~~SECRET~~

[REDACTED]

0001

0320

~~SECRET~~

PLAN FOR RETALIATORY GAS ATTACK ON GERMANY

.....  
 :Auth: CG,USSTAF;  
 :Date: 16 Jun 44;  
 :Initials: *ASP*;  
 :.....

Introduction

**SECRET**

Should the enemy initiate chemical warfare in "OVERLORD", or otherwise, the Allied Governments will decide whether retaliation is to be confined to the sphere of tactical operations assuming the enemy uses gas in this sphere only, or whether retaliation shall include the unrestricted use of gas against all types of objectives in Germany alone, or in Germany and the Satellite Countries.

Tactical Employment of Gas

2. It is axiomatic that should the enemy initiate gas warfare in the tactical sphere, the British and U.S. Forces will retaliate promptly in the tactical sphere. In order to determine whether the strategic bomber forces are in a position to employ gas weapons effectively in a tactical role, it is recommended that S.H.A.E.F. should call together forthwith a Committee consisting of representatives of the Air Staff, U.S.St.A.F.E., Bomber Command, 8th and 15th Air Forces, A.E.A.F. and 21 Army Group, to examine fully the problems involved and to make recommendations as to the optimum employment of gas. It is recommended further that this same Committee include recommendations as to the optimum employment of gas by the Tactical Air Forces.

Strategic Employment of Gas.

3. In considering the means by which chemical weapons can be employed most effectively in strategic attacks on Germany it is assumed that the respective Governments have directed the unrestricted use of gas against all types of objectives in Germany. It is clear that in such circumstances either of two conditions might exist:-

- (1) The Allied Governments agree simply that chemical warfare may be used without restriction against Germany.  
 In this case the strategic bomber forces are free to employ gas in the manner they consider will best contribute towards the aims of the existing bomber policy.  
 Plan I at Appendix 'A' has been produced on this assumption.
- (11) The Allied Governments decide not only to employ chemical warfare without restriction against Germany but to employ it on the heaviest scale against centres of German population, and in the manner best calculated to bring about a collapse of German morale.  
 In this case a complete change of current bombing policy would be involved and the objectives for strategic attack would be selected with the object of achieving a maximum impact upon the German people, with gas as the primary weapon.  
 Plan II at Appendix 'B' has been produced on this assumption.

4. The large scale use of gas from the air is an untried weapon of war. This factor, considered in relation to the size of the bomber forces and supplies of gas weapons available to us, and to the practical difficulties of applying a sufficient weight of gas to the selected targets, militates strongly against relying on all-out gas attack to force a decision unless it is known that morale in Germany is at such a critically low level that the use of gas in this manner

CLASSIFICATION CHANGED TO SECRET  
 DOD DIR 52009, 27 SEP 50  
*Thomas R. 1947-59*  
 NAME DATE

~~SECRET~~

~~SECRET~~

would tip the scales. In the absence of firm evidence what such a condition exists, it is considered that it would be most unwise to abandon the existing bombing policy, the success of which has been continuously and accurately evaluated, in favour of one whose potentialities must at the outset be incalculable.

5. The effectiveness of our well tried high explosive and incendiary weapons will, however, be materially increased by the complementary use of gas weapons. Plan I at Appendix 'A' has accordingly been designed with the object of employing chemical weapons in the manner best calculated to contribute to the success of current bombing policy. As the value of chemical weapons has not yet been proved by experience, provision has also been made in the Plan for large scale experimental attacks with the object of providing data on which to base subsequent policy.

6. In the light of the above, Plan I should be adopted. Plan II should be implemented only if there is overwhelming evidence that a critically low state of morale exists in Germany.

APPENDIX 'A'PLAN IRETALIATORY GAS ATTACK ON GERMANYIntroduction

On the initiation of gas warfare by the enemy, the strategic bomber forces will make unrestricted use of chemical warfare weapons in pursuance of their current bombing policy.

2. No alteration will be involved in the selection or the priority of current bombing objectives, but chemical warfare weapons will be employed in the attack of such objectives in the manner best calculated to increase the effectiveness of the attacks.

3. No operational experience is as yet available to indicate the relative value of chemical weapons in area attack as compared with H.E. and incendiary weapons. Large scale operations in the nature of trials are, therefore, desirable in order that such experience can be gained quickly. Methods of employing gas weapons must be modified progressively in the light of the experience gained.

Employment

4. On the initiation of chemical warfare, the R.A.F. and U.S. strategic air forces will employ gas weapons in the manner indicated below:-

R.A.F. Bomber Command

(1) (a) R.A.F. Bomber Command will launch heavy scale mustard attacks on selected industrial centres. The object will be to achieve within the built-up areas of these centres the concentrations of gas recommended in Porten Paper 1230/2 (T.4855) of the 12th April, 1943. These densities should be regarded as an absolute minimum.

(b) It is recommended that the loads carried in these attacks should be in the overall proportions of 75% mustard, 25% H.E.

~~SECRET~~

0 3 2 2

~~SECRET~~

The incorporation of 25% H.E. is calculated to increase the effect of the gas weapons by the breaking of windows and water mains and by the creation of rubble which presents specially difficult problems of decontamination. The H.E. bomb craters will also indicate the gas bomb distribution achieved, and thus help in evaluating results.

- (c) These heavy scale attacks are to be continued until one successful concentration on each of three different objectives have been accomplished.
- (11)(a) When the three successful concentrations referred to in (1)(c) above have been accomplished, and pending an evaluation of their effect, Bomber Command attacks are to continue with the incendiary as the primary weapon, H.E. and gas weapons being employed with incendiaries in a complementary role.
- (b) In these attacks, it is recommended that gas weapons be employed on the scale of phosgene 5%, and mustard 10% of the total bomb load despatched. It is essential that the phosgene and mustard bombs should be dropped in the opening phase of the attack.
- (c) The object of employing these quantities of gas weapons is to enforce upon the fire-fighters full anti-gas measures from the outset of the attack. Owing to its greater rate of diffusion, phosgene will ensure the immediate wearing of gasmasks and mustard will prolong the period over which respirators must be worn and will enforce the wearing of full anti-gas clothing.
- (11) When the effects of the full scale gas attacks have been assessed, our policy for the employment of gas weapons must be re-examined. If the effect upon German war economy is estimated to be less than that achieved through incendiary attack, the further employment of gas weapons must be in a complementary role with incendiaries as the primary weapon. On the other hand, if spectacularly successful results are achieved, a case for an all-out gas attack such as outlined in Plan II would merit serious consideration.

8th and 15th Air Forces.

- (iv) When conditions are such that visual bombing is possible it is recommended that gas weapons be employed in the following percentages which will be subject to modification in the light of experience:-
- (a) H.E. targets 95% H.E., 5% phosgene  
 (b) H.E./I.B. targets 90% H.E./I.B., 10% Mustard.
- (v) When conditions permit only area attack through overcast, these are to be made in the same manner as the heavy scale experimental attacks being undertaken by R.A.F. Bomber Command. It is recommended that the loads carried be similar, i.e. 75% mustard, 25% H.E., concentrations to be as decided by U.S. Air Forces. In this case three successful missions are to be flown against German cities with Berlin suggested as the priority target.
- (vi) Subsequent area attack policy will be subject to revision in the light of the experience of heavy scale mustard attacks which may be gained by the U.S. strategic air forces and R.A.F. Bomber Command.

~~SECRET~~ - 3 - ~~SECRET~~

SECRET

0 3 2 3



~~SECRET~~Supply of Gas Weapons

5. The supplies of British and U.S. gas weapons will be sufficient to implement this plan subject to the following provisos:-

- (i) Any employment of the strategic bomber forces in a tactical role involving the use of gas weapons will detract proportionately from the strategic gas effort;
- (ii) The allocation of gas weapons to the Tactical Air Forces is not on a scale appreciably greater than that hitherto envisaged.

APPENDIX "B"PLAN IIRETTALIATORY GAS ATTACK ON GERMANYIntroduction

In the event of the Allied Governments deciding to retaliate with gas against Germany on the heaviest possible scale against centres of population with the object of bringing about a collapse of German morale, the following Plan will be brought into effect.

Objectives

2. Objectives have been selected with the object of ensuring that attacks are directed against the maximum concentrations of population covering as wide a geographical area as possible, and embracing those centres which have not so far been subjected to heavy air bombardment and those which are thought likely to be psychologically sensitive to gas attack.

3. Bearing in mind the distribution of the bomber forces and the limited penetration of night bomber forces in the summer months, targets have been provisionally allocated as follows:

|                       |            |
|-----------------------|------------|
| R.A.F. Bomber Command | 15 targets |
| 8th Air Force         | 30 "       |
| 15th Air Force        | 15 "       |

4. The targets selected and their allocations to Commands are indicated in Annex I. These allocations are not rigid and may be varied by arrangement between the Commands concerned.

5. An appreciation by the Enemy Branch (F.O. and H.E.W.) showing the basis of selection is at annex II.

Weapons

overall

6. In the case of attacks by the R.A.F. Bomber Command, the following bomb loads are recommended:

|          |     |
|----------|-----|
| Mustard  | 50% |
| Phosgene | 25% |
| H.A.     | 25% |

~~SECRET~~

- 4 -

0 3 2 4

~~SECRET~~

The incorporation of 25% H.E. is calculated to increase the effect of the gas weapons by the breaking of windows and water mains and by the creation of rubble which presents specially difficult problems of decontamination. The H.E. bomb craters will also indicate the gas bomb distribution achieved, and thus help in evaluating results.

- (c) These heavy scale attacks are to be continued until one successful concentration on each of three different objectives have been accomplished.
- (11)(a) When the three successful concentrations referred to in (1)(c) above have been accomplished, and pending an evaluation of their effect, Bomber Command attacks are to continue with the incendiary as the primary weapon, H.E. and gas weapons being employed with incendiaries in a complementary role.
- (b) In these attacks, it is recommended that gas weapons be employed on the scale of phosgene 5%, and mustard 10% of the total bomb load despatched. It is essential that the phosgene and mustard bombs should be dropped in the opening phase of the attack.
- (c) The object of employing these quantities of gas weapons is to enforce upon the fire-fighters full anti-gas measures from the outset of the attack. Owing to its greater rate of diffusion, phosgene will ensure the immediate wearing of gasmasks and mustard will prolong the period over which respirators must be worn and will enforce the wearing of full anti-gas clothing.
- (11) When the effects of the full scale gas attacks have been assessed, our policy for the employment of gas weapons must be re-examined. If the effect upon German war economy is estimated to be less than that achieved through incendiary attack, the further employment of gas weapons must be in a complementary role with incendiaries as the primary weapon. On the other hand, if spectacularly successful results are achieved, a case for an all-out gas attack such as outlined in Plan II would merit serious consideration.

8th and 15th Air Forces.

- (iv) When conditions are such that visual bombing is possible it is recommended that gas weapons be employed in the following percentages which will be subject to modification in the light of experience:-
- (a) H.E. targets 95% H.E., 5% phosgene
  - (b) H.E./I.B. targets 90% H.E./I.B., 10% Mustard.
- (v) When conditions permit only area attack through overcast, these are to be made in the same manner as the heavy scale experimental attacks being undertaken by R.A.F. Bomber Command. It is recommended that the loads carried be similar, i.e. 75% mustard, 25% H.E., concentrations to be as decided by U.S. Air Forces. In this case three successful missions are to be flown against German cities with Berlin suggested as the priority target.
- (vi) Subsequent area attack policy will be subject to revision in the light of the experience of heavy scale mustard attacks which may be gained by the U.S. strategic air forces and R.A.F. Bomber Command.

~~SECRET~~

SECRET

0 3 2 5

~~SECRET~~

Supplies will not be sufficient to enable these proportions to be maintained. They should, however, be maintained within the limitations of each monthly allocation of gas weapons, and when these are expended subsequent attacks within the month should employ gas only as a harassing agent.

7. The U.S. strategic bombers will employ the same proportions as far as phosgene stocks permit.

8. The quantities of phosgene weapons advocated above are to be employed subject to adequate provision having been made for the use of phosgene in tactical operations, for which it is especially suitable.

9. Any shortages in phosgene weapons are to be made good by the substitution of mustard weapons.

Supply of Gas Weapons.

10. The extent to which, and the rate at which this plan can be implemented will depend upon:-

(i) The specific amounts of gas required to produce effective results; this can only be determined in the light of experience.

(ii) The extent to which tactical demands impinge upon strategical requirements both in terms of weapons and effort.

11. As a general indication of our capabilities at the present time the total stocks of British and U.S. chemical weapons now existing in the European theatre are sufficient, if wholly devoted to implementing this plan, to achieve the theoretical density required over an area of approximately 3 square miles in each of the 60 selected targets set out in Annex I.

- 5 -

~~SECRET~~

0 3 2 6

~~SECRET~~

ANNEX I

PROVISIONAL ALLOCATION OF TARGETS FOR GAS ATTACK UNDER PLAN II  
(In Order of Priority)R.A.F. BOMBER COMMAND (15 targets)Western Germany

Essen  
Cologne  
Duisburg  
Dusseldorf  
Gelsenkirchen  
Wuppertal  
Bochum  
Oberhausen/Mulheim  
Munster  
Solingen  
Hagen  
Krefeld  
Aachen  
Munchen-Gladbach  
Remscheid

U.S. 8th AIR FORCE (30 targets)

| <u>N.W. Germany</u> | <u>S.W. Germany</u>   | <u>N &amp; Central Germany</u> | <u>E. Germany</u> |
|---------------------|-----------------------|--------------------------------|-------------------|
| Hamburg             | Frankfurt/Main        | Berlin                         | Konigsberg        |
| Bremen              | Mannheim/Ludwigshafen | Dresden                        | Danzig            |
| Kiel                | Wiesbaden             | Leipzig                        |                   |
| Hanover             | Mainz                 | Chemnitz                       |                   |
| Brunswick           | Saarbrucken           | Magdeburg                      |                   |
| Lubeck              | Darmstadt             | Stettin                        |                   |
| Bielefeld           |                       | Dessau                         |                   |
| Osnabruck           |                       | Halle                          |                   |
| Rostock/Warnemunde  |                       | Potsdam                        |                   |
| Wilhelmshaven       |                       | Erfurt                         |                   |
|                     |                       | Wurzburg                       |                   |
|                     |                       | Kassel                         |                   |

U.S. 15th AIR FORCE (15 targets)

| <u>Southern Germany</u> | <u>Silesia</u> |
|-------------------------|----------------|
| Munich                  | Breslau        |
| Stuttgart               | Hindenburg     |
| Nuremberg               | Gleitwitz      |
| Freiburg/1/B            | Seuthon        |
| Karlsruhe               |                |
| Augsburg                |                |
| Heilbrunn-Neckarsulm    |                |
| Furth                   |                |
| Pforzheim               |                |
| Regensburg              |                |
| Ulm                     |                |

~~SECRET~~

- 6 -

0 3 2 7

**SECRET**

ANNEX II

TARGET PRIORITIES FOR CHEMICAL WARFARE ATTACK  
AGAINST GERMAN TOWNSI. INTRODUCTION

This paper is concerned with the selection of the German towns against which C.W. attacks should be directed on the assumptions that:-

- a) unrestricted C.W. attack of the civilian population of Germany proper (but not Austria) has been approved;
- b) the primary objective of the attack would be the morale of the civil population;
- c) the whole of the resources of the U.S. 8th and 15th Air Forces and of R.A.F. Bomber Command are available for the purpose.

II. FACTORS RELEVANT TO THE CHOICE OF TARGETS

If the primary object of this attack would be to break civilian morale it would be wise to aim at the maximum percentage of the enemy's total population which can be covered effectively with the forces available.

If the maximum effect is to be obtained on morale, individual targets should be selected from every geographical area of Germany so that no section of the population remains entirely untouched.

Although the initial effect of the use of an unknown and much feared weapon will be considerable everywhere, it will be greatest in Southern, South-Eastern and Eastern Germany (i.e. Bavaria, Saxony and Silesia) which have been comparatively lightly affected hitherto and have not therefore been conditioned to air attacks of any kind to the same extent as the Rhineland and Central and N.W. Germany.

III. ANALYSIS OF GERMAN TOWNS

The population of the major German towns has altered considerably due to evacuation and has in the aggregate been reduced since the refugees from the large towns have been redistributed among the small towns and in rural districts rather than in other large towns. Accurate computation of the present population of individual towns is impossible. Although fairly accurate estimates can be made by study of evacuation orders etc. of the numbers evacuated from time to time, there is no sure means of assessing the volume of the drift back which is known in many cases to have been considerable.

Nevertheless an attempt has been made in Appendix I. to estimate the population of the 60 largest towns in Germany as at March 31st 1944 taking into account evacuation and the subsequent return of population. Figures of "normal" population are given for comparison. These towns are estimated to have an aggregate current population of over 22 million persons, which is rather more than one-quarter of the total population of Greater Germany.

- 7 -

**SECRET**

0 3 2 8

~~SECRET~~

Estimates of population alone, however, do not give an adequate guide to comparative importance of German towns as targets for C.W. attack. In the more heavily damaged towns the population is dispersed to a large extent in the suburbs and in the "shanty cities" which are appearing to an increasing extent in woods and open spaces on the outskirts. In so far as the more densely built-up portions of these towns have been destroyed and are now largely uninhabited the population by reason of its greater dispersal will be less vulnerable to C.W. attack of a given weight and such towns must consequently be considered less effective targets than those in which damage in previous attacks has not been so severe.

A column has therefore been included in Appendix I. to show the percentage of buildings which have been seriously damaged in each town (as calculated by R.E.8) and in order to provide a rough factor of current comparative importance which takes into account the element of vulnerability, this percentage has been applied to the estimate of current population to give a "target factor".

In order to facilitate the allocation of targets between the various Commands the towns have been classified in geographical areas conforming roughly to current operational capabilities.

#### IV. CONCLUSIONS

- (1) As a result of the analysis described above, the towns most suitable as targets for C.W. attack are assessed as follows. Comparative target values, based on estimated present population and damage status, are given by means of the "target factor."

##### A. RUHR-RHINELAND AREA

(Accessible to night attack by R.A.F. Bomber Command during the summer months).

|                  | <u>Target Factor</u> |
|------------------|----------------------|
| Essen            | 375                  |
| Cologne          | 342                  |
| Duisburg         | 308                  |
| Dusseldorf       | 270                  |
| Frankfurt/Main   | 240                  |
| Gelsenkirchen    | 237                  |
| Wuppertal        | 158                  |
| Bochum           | 154                  |
| Wiesbaden        | 138                  |
| Oberhausen       | 136                  |
| Munster          | 114                  |
| Solingen         | 112                  |
| Hagen            | 104                  |
| Mainz            | 100                  |
| Krefeld          | 98                   |
| Darmstadt        | 95                   |
| Aachen           | 86                   |
| Mulheim          | 85                   |
| Munster-Gladbach | 60                   |
| Renscheid        | 40                   |

~~SECRET~~~~SECRET~~ 8 ~~SECRET~~

0 3 2 9



B. N.W. GERMANY~~SECRET~~

(Accessible to R.A.F. Bomber Command after the end of July).

|                    | <u>Target Factor</u> |
|--------------------|----------------------|
| Hamburg            | 490                  |
| Bremen             | 300                  |
| Kiel               | 200                  |
| Hanover            | 152                  |
| Brunswick          | 147                  |
| Lubeck             | 100                  |
| Bielefeld          | 98                   |
| Osnabruck          | 80                   |
| Rostock/Warnomunde | 70                   |
| Wilhelmshaven      | 60                   |

C. NORTHERN & CENTRAL GERMANY

|           |       |
|-----------|-------|
| Berlin    | 2,250 |
| Dresden   | 650   |
| Leipzig   | 488   |
| Chemnitz  | 350   |
| Magdeburg | 266   |
| Stettin   | 243   |
| Dessau    | 186   |
| Halle     | 175   |
| Potsdam   | 136   |
| Erfurt    | 135   |
| Wurzburg  | 120   |
| Plauen    | 100   |
| Kassel    | 67    |

D. SOUTH-WESTERN GERMANY

(Accessible to R.A.F. Bomber Command after the end of July and possibly in part to U.S. 15th A.F.)

|                       |     |
|-----------------------|-----|
| Stuttgart             | 300 |
| Mannheim/Ludwigshafen | 220 |
| Freiburg/1/B          | 130 |
| Karlsruhe             | 115 |
| Saarbrücken           | 100 |

E. EASTERN GERMANY

(Deep penetration for all Commands)

|            |     |
|------------|-----|
| Breslau    | 700 |
| Konigsberg | 370 |
| Danzig     | 270 |
| Hindenburg | 150 |
| Gleiwitz   | 140 |
| Bythen     | 120 |
| Cerlitz    | 110 |

~~SECRET~~

~~SECRET~~7. SOUTHERN GERMANY

(Accessible to U.S. 15th Air Force)

Target Factor

|          |     |
|----------|-----|
| Munich   | 675 |
| Munzburg | 289 |
| Augsburg | 87  |

- (11) Attack of all the 55 towns listed above would affect more than 25% of the population of Greater Germany. The outstanding targets for C.W. attack, having regard to their size and previous history, and regardless of location are:

Berlin  
 Breslau  
 Dresden  
 Munich

- (111) The list furnished above may not provide sufficient targets within range of the normal penetration of the U.S. 15th Air Force. There is, unfortunately, an insufficiency of large towns in South Germany. A supplementary list of smaller towns in South Germany from which additional targets could be drawn is given in Appendix II.

Enemy Branch  
 (F.O. and H.B.W.)

21.5.44

~~SECRET~~

- 10 -

0 3 3 1

~~SECRET~~  
APPENDIX I

POPULATION AND DAMAGE STATUS OF GERMAN TOWNS OF MORE THAN

100,000 INHABITANTS

| <u>TOWN</u>                              | <u>NORMAL<br/>POPULATION</u> | <u>ESTD. PRESENT<br/>POPULATION</u> | <u>% OF SERIOUS<br/>DAMAGE**</u> | <u>TARGET<br/>FACTOR</u> |
|--|------------------------------|-------------------------------------|----------------------------------|--------------------------|
| <u>A. RUHR-RHINELAND</u>                 |                              |                                     |                                  |                          |
| Aachen                                   | 162,000                      | 130,000                             | 33%                              | 86                       |
| Bochum                                   | 305,000                      | 185,000                             | 17%                              | 154                      |
| Cologne                                  | 772,000                      | 570,000                             | 40%                              | 342                      |
| Darmstadt                                | 115,000                      | 95,000                              | small*                           | 95                       |
| Duisburg                                 | 435,000                      | 335,000                             | 8%                               | 308                      |
| Dusseldorf                               | 541,000                      | 420,000                             | 36%                              | 270                      |
| Essen                                    | 667,000                      | 467,000                             | 20%                              | 375                      |
| Frankfurt/Main                           | 553,000                      | 413,000                             | 42%                              | 240                      |
| Gelsenkirchen                            | 317,000                      | 237,000                             | small*                           | 237                      |
| Hagen                                    | 152,000                      | 122,000                             | 15%                              | 104                      |
| Krefeld                                  | 171,000                      | 131,000                             | 25%                              | 98                       |
| Mains                                    | 158,000                      | 118,000                             | substantial*                     | 100†                     |
| Mülheim (Ruhr)                           | 137,000                      | 110,000                             | 23%                              | 85                       |
| München/Gladbach                         | 128,000                      | 96,000                              | 37%                              | 60                       |
| Münster                                  | 141,000                      | 120,000                             | 5%                               | 114                      |
| Oberhausen                               | 192,000                      | 152,000                             | 10%                              | 136                      |
| Ramscheid                                | 105,000                      | 85,000                              | 53%                              | 40                       |
| Solingen                                 | 140,000                      | 112,000                             | small*                           | 112                      |
| Wiesbaden                                | 170,000                      | 138,000                             | small*                           | 138                      |
| Wuppertal-Barmen)                        | 401,000                      | 240,000                             | 33%                              | 158                      |
| Wuppertal-                               |                              |                                     |                                  |                          |
| Elberfeld )                              |                              |                                     |                                  |                          |
| <u>B. NORTH-WEST GERMANY</u>             |                              |                                     |                                  |                          |
| Bielefeld                                | 130,000                      | 98,000                              | small*                           | 98                       |
| Bremen                                   | 424,000                      | 354,000                             | substantial*                     | 300†                     |
| Brunswick                                | 196,000                      | 156,000                             | 6%                               | 147                      |
| Hamburg                                  | 1,712,000                    | 1,000,000                           | 51%                              | 490                      |
| Hanover                                  | 471,000                      | 271,000†                            | 44%                              | 152†                     |
| Kiel                                     | 274,000                      | 234,000                             | substantial*                     | 200†                     |
| Lubeck                                   | 155,000                      | 110,000                             | substantial*                     | 100†                     |
| Osnabruck                                | 100,000                      | 80,000                              | small*                           | 80                       |
| Rostock/Warnemunde                       | 131,000                      | 91,000                              | substantial*                     | 70†                      |
| Wilhelmshaven                            | 113,000                      | 83,000                              | substantial*                     | 60†                      |
| <u>C. NORTHERN &amp; CENTRAL GERMANY</u> |                              |                                     |                                  |                          |
| Berlin                                   | 4,350,000                    | 2,750,000†                          | 18%                              | 2,250                    |
| Chemnitz                                 | 337,000                      | 350,000†                            | nil                              | 350                      |
| Dessau                                   | 119,000                      | 186,000†                            | nil                              | 186                      |
| Dresden                                  | 630,000                      | 650,000†                            | nil                              | 650                      |
| Erfurt                                   | 165,000                      | 135,000                             | nil                              | 135                      |
| Halle                                    | 220,000                      | 175,000                             | nil                              | 175                      |

- 11 - ~~SECRET~~

~~SECRET~~

| TOWN   | <u>ESTD. POPULATION</u> | <u>PRESENT POPULATION</u> | <u>% OF SERIOUS DAMAGE**</u> | <u>TARGET FACTOR</u> |
|--|-------------------------|---------------------------|------------------------------|----------------------|
| <u>C. NORTHERN &amp; CENTRAL GERMANY (CONT.)</u> |                         |                           |                              |                      |
| Kassel   | 216,000                 | 146,000                   | 54%                          | 67                   |
| Leipzig  | 707,000                 | 677,000                   | 28%                          | 488                  |
| Magdeburg  | 337,000                 | 272,000                   | 2%                           | 266                  |
| Plauen   | 112,000                 | 100,000?                  | nil                          | 100                  |
| Potsdam  | 136,000                 | 136,000                   | nil                          | 136                  |
| Stettin  | 383,000                 | 303,000                   | 20%                          | 243                  |
| Wurzburg   | 107,000                 | 120,000?                  | nil                          | 120                  |
| <u>D. SOUTH-WESTERN GERMANY</u>                  |                         |                           |                              |                      |
| Freiburg 1/B                                     | 110,000                 | 130,000?                  | nil                          | 130                  |
| Karlsruhe  | 190,000                 | 150,000?                  | substantial*                 | 115?                 |
| Mannheim/<br>Ludwigshafen                        | 430,000                 | 348,000                   | 37%                          | 220                  |
| Saarbrücken                                      | 133,000                 | 113,000                   | small*                       | 100                  |
| Stuttgart  | 458,000                 | 343,000                   | 12%                          | 300                  |
| <u>E. EASTERN GERMANY</u>                        |                         |                           |                              |                      |
| Beuthen  | 101,000                 | 120,000?                  | nil                          | 120?                 |
| Breslau  | 630,000                 | 700,000?                  | nil                          | 700?                 |
| Danzig   | 260,000                 | 260,000?                  | negligible                   | 270?                 |
| Görlitz  | 117,000                 | 140,000?                  | nil                          | 140?                 |
| Görlitz  | 94,000                  | 110,000?                  | nil                          | 110?                 |
| Hindenburg                                       | 126,000                 | 150,000?                  | nil                          | 150?                 |
| Königsberg                                       | 370,000                 | 370,000?                  | negligible                   | 370?                 |
| <u>F. SOUTHERN GERMANY</u>                       |                         |                           |                              |                      |
| Augsburg   | 186,000                 | 146,000                   | 40%                          | 87                   |
| Munich   | 830,000                 | 710,000                   | 5%                           | 675                  |
| Munich   | 423,000                 | 328,000                   | 12%                          | 289                  |

\*\* Situation at March 31st 1944 as reported by R.E.S on the basis of available cover.

\* R.E.S assessments not available.

~~SECRET~~

- 12 -

0 3 3 3

~~SECRET~~  
APPENDIX ~~SECRET~~

SMALLER TOWNS IN SOUTH GERMANY

(Accessible to U.S. 15th A.F.)

| <u>TOWN</u>              | <u>NORMAL<br/>POPULATION</u> | <u>ESTD. PRESENT<br/>POPULATION</u> | <u>% OF SERIOUS<br/>DAMAGE</u> | <u>TARGET<br/>FACTOR</u> |
|--------------------------|------------------------------|-------------------------------------|--------------------------------|--------------------------|
| Pforzheim                | 80,000                       | 80,000                              | nil                            | 80                       |
| Ulm                      | 74,000                       | 74,000                              | small                          | 74                       |
| Heilbronn-<br>Neckarsulm | 85,000                       | 85,000                              | nil                            | 85                       |
| Regensburg               | 95,000                       | 75,000                              | small                          | 75                       |
| Furth                    | 82,000                       | 82,000                              | small                          | 82                       |
| Bamberg                  | 59,000                       | 59,000                              | nil                            | 59                       |

- 13 -

~~SECRET~~

0 3 3 4



0 3 3 5





0 3 3 6



0337



0 3 3 8

DECLASSIFIED  
EO 13526

522.6011-1  
44/05/01  
RETURN TO  
AFSHHC  
MAXWELL AFB AL 36112

5-945

22 The American Embassy  
Miami, Moscow, 1st / 2nd  
x 2

1029153

0 3 3 9

SUPPLY DIVISION  
NAVAL DIVISION

AMERICAN EMBASSY  
UNITED STATES MILITARY MISSION  
MOSCOW,  
UNION OF SOVIET SOCIALIST REPUBLICS

|             |           |                        |
|-------------|-----------|------------------------|
| MAXWELL AIR | RETURN TO | 522.6011-1<br>44/05/01 |
| AFSHIBO     |           |                        |
| 1 May 1941. |           |                        |

Colonel Alfred A. Kessler,  
Headquarters Provisional Eastern Command,  
Tehran, U.S.S.R.

Dear Aaron:

Immediately upon my return from Voltau, I wrote to General Nikitin about clearance of the C-57's and asked for an immediate appointment. I had one with General Levandovich last night, and he assures me that instructions have been issued which will provide for daily flights of our C-57's, and which he feels will take care of this situation. I also brought the question up of allowing us more latitude in the evaluation of weather. This was at the request of the APO in Teheran who feel that they are unduly restricted by the Russians. Levandovich agreed that they should be given more latitude and wanted my assurance that the crews were well trained for instrument flights. I told him that they were.

Nikitin sent word by Levandovich that he wanted instructions issued that we would not use our communications to Italy or to London until as late as possible prior to the start of operations. I explained, of course, that we would have to test the communications, and also we would have to be in communication with London and Italy for some period prior to the actual start of operations in order to make the arrangements. They agreed that this would be necessary but said that the Germans would immediately pick up our radio station when we broadcast and possibly some German bombers would be attracted to Voltau in an effort to put us out of commission before we got started. I, therefore, asked them to send the message which you undoubtedly received on this subject. What I would like to do now is to get your views as to when communications should be started and with all the arguments you can assemble. The above, of course, applies only to transmitting, and there will be no objection to London or Italy sending you messages which can be answered through my office. I know this will be a disappointment to you as it continues your isolation, but I can see some merit to their argument.

I feel confident that I will set up radio communications with you, and I have asked that a set be sent to Teheran at once from Cairo. At best, however, I do not expect that this can be set up in less than

CLASSIFICATION CHANGED TO SECRET  
REF ID: A66666, 22 SEP 58  
*E. Thomas* 18a 31  
NAME DATE

~~SECRET~~  
BY APR 21 95 R 30

1029153

0340

SECRET

two weeks, so in the interim we will just have to make the best of communicating through Ferninov and Nikitin.

The letters you sent me were finally delivered to me last night. Their story was that they were sent up by a crew who didn't know what to do with them and therefore turned them in to their intelligence people. They complained because the letter was not marked "Secret" on the outside and given a serial number. Also it was sealed with sealing wax with the imprint of a fifty kopeck piece. In the future will you mark your letters to me "Secret" on the outside, and underneath the "Secret" give them some serial number selected arbitrarily and use something that looks official on the sealing wax such as a West Point ring or perhaps Ferninov could give you some official seal. I will do the same in my letters to you.

We have received a new Studebaker which I am sending to you. General Levenovich stated that the Red Air Force would take the responsibility for its delivery, but because of these holidays could do nothing about it until May 5. I hope, therefore, you get it within a week or ten days.

I am enclosing a group of messages sent and received, all of which have been paraphrased. In this connection, may I caution you about the security of any of our messages that you have on the sink ship. I think you should hold them in a safe until either Wend or I come down there, at which time we can either bring them back or, if you prefer, you can keep them provided you are certain they will not get into Soviet channels. Of course, as you know, we are not concerned as much as to the secrecy of the contents of the messages but as to the security of our codes.

We still have no reply on communications between Feltova and Federal, but I will keep after it and hope to get you an answer soon. If we can just get that in, it will provide you with rapid means of communication with London and Italy.

I can't tell you how glad I was to see you and Paul and the rest of your staff the other day. Certainly you are all working under the most adverse circumstances, and you are doing a swell job in sustaining everyone's interest. I didn't see a glory page in the lot, and I know you are going to get this thing over in great shape. We are going to overcome all of our difficulties, but I agree with you it is going to be at Russian tempo.

Please give my regards to Paul and the rest of the crowd. With kindest regards to you.

Cordially yours,

*Be sure and shout if I can help you in any way!!*

SECRET

0 3 4 1





0 3 4 2



0 3 4 3



0 3 4 4



0 3 4 5

1029154

373.2

S. 293.

FILE IN  
CLASSIFIED FILES

F.T.O.-Box-331

Filed - 1 of 1/1/43

DECLASSIFIED  
EO 11652

Sub 1. Cr. 4.

~~SECRET~~  
FRANTIC VII

0 3 4 6

SECRET  
HEADQUARTERS  
EASTERN COMMAND  
USSTAF

INCOMING MESSAGE

|                |                   |
|----------------|-------------------|
| PRECEDENCE     | URGENT            |
| CLASSIFICATION | <del>SECRET</del> |
| DATE           | TOOT: 241515A     |
| SEPT 24, 1944. | RECD: 241626Z     |
| FROM: BARI     | SERIAL NR. KC1710 |
| TO: POLTAVA    |                   |

ARRIVALS OF EIGHT MUSTANS AND TEN RPTTEN RPT ONE ZERO PAREN  
INFO MAAF CG EASTCOM CG USSTAF EIGHT AF FROM CITE XVAF EASY  
TWO FIVE FIVE SEVEN SECRET PAREN FORTRESSES AT ITALIAN  
BASES ON TWO FOUR SEPTEMBER AT ONE ONE ZERO ZERO ABLE  
HOURS PD THESE ARE FRANTIC SEVEN AIRCRAFT.

MCR 111



CRYPTOCOT

BY: 1045  
DATE: 2/7  
TIME: 1045Z

~~SECRET~~

THE MAKING OF AN EXACT COPY OF THIS MESSAGE IS FORBIDDEN. ONLY SUCH  
EXTRACTS AS ARE ABSOLUTELY NECESSARY WILL BE MADE AND PROPERLY  
CLASSIFIED.

0 3 4 7



JEMP V JBPD NR 33 PRIORITY  
FROM JBPD 201327Z

TO JEMP  
GR 131 BT

SECRET  
R-6  
063124T

ARIAN IRON RPT HUNGARIAN IRON AND STEEL MACHINERY WORKS AT BICOZYOR  
RPT BICOZYOR ATTACKED BY SEVEN THREE BAKER SEVENTEENS RETURNING FROM  
EASCOM ON ONE THREE SEPTEMBER PD ONE BAKER SEVENTEEN ATTACKED OPPORTUN-  
ITY RPT OPPORTUNITY TARGET PAREN TO WALSH FROM DOOLITTLE SIGNED SPAATZ  
DOG SIX THREE ONE TWO FOUR PAREN TOTAL OF SEVEN FIVE BOMBERS DISPATCHED  
PD ONE BAKER SEVENTEEN RETURNED EARLY DUE TO MECHANICAL FAILURE PD  
CREW REPORT VERY GOOD BOMBING AT BICOZYOR PD THERE WAS NO ENEMY AIR  
OPPOSITION PD ONLY FLAK WAS MEAGER INACCURATE AT TARGET PD SEVEN FOUR  
BOMBERS REACHED ITALY SAFELY PD ONE SEVEN SEPTEMBER SEVEN THREE FORTRESS-  
ES WERE DISPATCHED TO RETURN TO ENGLISH BASES PD AIRCRAFT CARRIED NO  
BOMBS AND DID NOT ATTACK PD ALL AIRCRAFT ARRIVED SAFELY IN UNITED  
KINGDOM PD REMAINING AIRCRAFT EXPECTED TO RETURN INDIVIDUALLY PD 00000  
PD ROYAL HUNG

JW

BT -00145Z

RECD 201350Z GFG

3604  
DECC

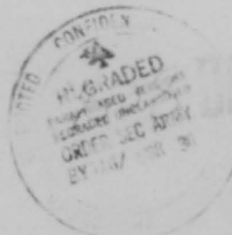

SECRET

0348

JMYP V JJUL 1818AA URGENT SOURCE  
FROM JJCO 200022A K01300

SECRET

*C/ps*

TO JMYP

JMYP

URGENT

*4*

JJUL

CG - DT

*F 0 157*

AMEND OUR EAST DASH TWO ONE FOUR NINE TO READ NINE TWO DASH TWO  
CG AAF 070 CG DITH AF CG USSTAF CG EASTERN DASH DASH FROM TWENTY  
CITY WAF EAST DASH DASH SECRET JMYP FLC DASH TO USSTAF AND DTN AF  
DASH FORTRESS ARRIVED IN ITALY DO ONE PORT RETURNED SAFELY TO  
MOLTAVA

BT 200022A

BTCD 001/111 2000007

SEARCHED  
INDEXED  
SERIALIZED  
FILED  
BY  
JUL 1953

*3600*

*412  
53*

0 3 4 9

JUMP V JUEL NR1029 URGENT MESSAGE

FROM JJCC 191745A 101359

TO JUMP

GRV DT

11- Cope  
URGENT [E 2149] \$  
FRTA WPT FRANTIC SEVEN LANDED IN ITALY ONE SIX ZERO ZERO ABLE CMA  
ONE NINE PAREN TO CG AAFWTC CG NIG TH AIRFORCE WALS AND CG MUSTAF  
JUMP PL PACC MUSTAF AND NIG TH AIRFORCE FROM TWINGING CITY WVAF  
EACH DAY TWO ONE FOUR NINE PD SECURITY SECRET PAREN SEPTEMBER PD  
NINE THREE FORTRENGTH OPT FORTRENGTH CMA FIVE FIVE MUSTANGS CMA  
AND TWO HOONHITCHER PD COL TRUMBALL STATED TWO TWO OF HIS AIRCRAFT  
DEVELOPED RUSSIAN DATA

DT 191745A

DECD AT 200927

VACCA



350 Duplicate of 3596

2009342

2micr58

0 3 5 0

JBMP V JJHL NR1853 "URGENT QED"

FROM 77N CM282 1920123

TO JBMP

JBPD

JJHL

CR 32 BT

KAPTAIN CARNEY LANDED SAN SEVERO ONE NINE SEPTEMBER PAREN TO EAKER  
FOR WALSH INFO SPAATZ FROM ABLE DASH TPREE VAPRW CITE PWR ONE ZERO  
TWO THREE DASH CHARLIE PAREN PD

BT 1920123

RECD AT 192030Z ACB

SECRET

et  
ed  
Ops

PWR 1023

3585  
SECRET

RECEIVED BY AB 19/2030  
REGISTRATION  
19/2030  
SECRET

SECRET  
 HEADQUARTERS  
 EASTERN COMMAND  
 USSTAF  
 INCOMING MESSAGE

|                |        |
|----------------|--------|
| PRECEDENCE     | URGENT |
| CLASSIFICATION | SECRET |

URGENT

DATE SEPT. 20, 1944 T00:200035A  
 RECD:200400Z SERIAL NR. KC 1375  
 FROM: BARI  
 TO: POLTAVA

FRANTIC SEVEN LANDED IN ITALY ONE SIX XERO XEROABNE CMA ONE NINE  
 SEPT PD NINE THREE FORTRESSES CMA FIVE FIVE MUSTANGS BRAC  
 WALSH FROM TWINING XAAF EASY DASH TWO ONE FOUR NINE BRAC CMA  
 AND TWO MOSQUITOES PD COL TRUESDALE STATES TWO TWO OF HIS  
 AIRCRAFT REMAINED RUSSIAN BASES

MCR 11



CRYPTOCAPTION  
 BY 325  
 DATE 20  
 TIME 0412Z

SECRET

THE MAKING OF AN EXACT COPY OF THIS MESSAGE IS FORBIDDEN. ONLY SUCH  
 EXTRACTS AS ARE ABSOLUTELY NECESSARY WILL BE MADE AND PROPERLY  
 CLASSIFIED.

0 2 4 1  
 0 3 5 2

*aps*

WRE V ALS NR 264 R-A-ALG 181828Z WRE BT  
THREE CASUALTIES'. ONE DEAD ON ARRIVAL. TWO RELATIVELY MINOR CASUALTIES  
REMOVED IN GOOD CONDITION AT PRESENT.

BARLBERG

BT PK  
WRE R..181848Z WAS

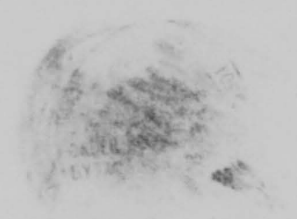

0 3 5 3



NOTIFICATION SLIP | OPERATIONS SECTION | DATE .....  
RADIO NO. 3252 FROM TAFE THE FIELD .....  
THE LEGAL .....  
NOTIFICATION TIME THE ..... TIME ..... METHOD ..... UNIT .....

- GENERAL MESSAGE .....
- C & EC .....
- ECSSM .....
- AAF STATION 550 .....
- AAF STATION 550 .....
- AAF STATION 551 .....
- DEP SO FOR AAF .....
- COMMUNICATIONS .....
- INTELLIGENCE .....
- POSTER ON BOARD .....
- BASE OPERATIONS .....

107- B17  
73- 5/1  
1 - 11000

0 3 5 4

SECRET

*opt*

P7

JBMP V JBPD NR 36 URGENT  
FROM JSAF 131345B SEPT 44  
TO JBPD  
JBMP  
GR 51 BT

DG1127

107  
73  
1/11/44

ONE ZERO SEVEN BAKER ONE SEVENS AND ESCORT OF SEVEN THREE  
PETER FIVE ONES AND ONE MOSQUITO WEATHER SHIP AIRBORNE ON  
FRANTIC SEVEN MISSION PAREN DOOLITTLE TO WALSH SGT SPAATZ  
DOC SIX ONE ONE TWO SEVEN PAREN ATTACKED TARGET AND PROCEEDING  
TO ESCOM BASES

3553

RECD CRYPTO 131345Z

RECEIVED  
REGRADED  
BY THE SEC ARMY  
BY THE SEC ARMY

13492

0355

JEMP V JBPD NR 26 C P  
 FROM JBPD 181138Z  
 TO JEMP  
 GR 164 BT

INTERROGATION REPORT REQUIRED AS EARLY AS POSSIBLE FOR CONSIDERATION  
 POSSIBLE FRANTIC EIGHT PD TO WALSH FROM SPAATZ UNCLE SIX EIGHT  
 ONE SEVEN EIGHT PD PARTICULAR EMPHASIS SHOULD BE PLACED ON THE  
 FOLLOWING CLM ABLE PD PERCENTAGE OF SUPPLIES LANDED IN DROPPING  
 ZONES PD BAKER PD PERCENTAGE OF SUPP

LIES WITHIN THE CITY OF  
 WARSAW PD CHARLIE PD RECOMMENDATIONS FOR IMPROVEMENT OF ACCURACY  
 PD BOG PD FLAK LOSSES AND DAMAGE PD EARLY PD DISPOSITION AND TYPE  
 OF FLAK ENCOUNTERED IN VICINITY OF WARSAW PD FOX PD INCIDENTS CMA  
 IF ANY CMA FROM RUSSIAN DEFENSES TO CITY CMA XXXXBT  
 IF ANY CMA FROM RUSSIAN DEFENSES PD GEORGE PD RECOMMENDATIONS  
 FOR IMPROVEMENT OF DROPPING TACTICS INCLUDING APPROACHES TO CITY  
 CMA IDENTIFICATION OF DROPPING ZONES CMA SIGNALS FROM THE INSURGENTS  
 AND ANY OTHER COMMENTS PERTINENT PD NOW PD LATEST INFORMATION ON  
 PROGRESS AND CAPABILITIES OF RUSSIANS IN THE ASSAULT ON WARSAW PD  
 ITEM PD LATEST DATE YOU FEEL YOU CAN HOLD OPEN EASTCOAST PD JIG PD  
 QUERY DO YOU HAVE SUFFICIENT SUPPLIES TO RECEIVE AND UNLOAD  
 ANOTHER BOMBER MISSION

BT 181126Z  
 RECD 181138Z CEN

*Handwritten:* 181147Z  
 354  
 [Circular stamp: DEPT OF DEFENSE, MAR 12 1952]  
 [Handwritten: MAR 12]

0356

INTERROGATION REPORT REQUIRED AS EARLY AS POSSIBLE. PARTICULAR EMPHASIS SHOULD BE PLACED ON THE FOLLOWING:

- A. PERCENTAGE OF SUPPLIES LAUNDED IN DROPPING ZONES.
- B. PERCENTAGE OF SUPPLIES WITHIN THE CITY OF WARSAW.
- C. RECOMMENDATIONS FOR IMPROVEMENT OF ACCURACY.
- D. FLAK LOSSES AND DAMAGE.
- E. DISPOSITION AND TYPE OF FLAK ENCOUNTERED IN VICINITY OF WARSAW.
- F. INCIDENTS, IF ANY, FROM RUSSIAN DEFENSES ~~OUT~~ TO CITY.
- G. RECOMMENDATIONS TO IMPROVEMENT OF DROPPING TACTICS INCLUDING APPROACHES TO CITY, IDENTIFICATION OF DROPPING ZONES, SIGNALS FROM INSURGENTS AND ANY OTHER COMMENTS PERTINENT.
- H. LATEST INFORMATION ON PROGRESS AND CAPABILITIES OF RUSSIANS IN THE ASSULT ON WARSAW.

I *Early flak report to this has of battle damages losses.*

0357

MESSAGE ROUTING SLIP  
From Deputy Comdr for Ops

|                      |          |              |          |                  |            |
|----------------------|----------|--------------|----------|------------------|------------|
| MESSAGE NUMBER :     | 56       | SIGNALS NO : |          | CLASSIFICATION : |            |
| LOG NO :             | 3543     |              |          |                  |            |
| ROUTED TO :          | FOR :    | FOR :        | CC. TO : |                  | INITIALS : |
|                      | ACTION : | INFO :       |          |                  |            |
| Deputy CC<br>for Ops | ✓        |              |          |                  | *          |
|                      |          |              |          |                  |            |
|                      |          |              |          |                  |            |
|                      |          |              |          |                  |            |
|                      |          |              |          |                  |            |
|                      |          |              |          |                  |            |
|                      |          |              |          |                  |            |
|                      |          |              |          |                  |            |
|                      |          |              |          |                  |            |
|                      |          |              |          |                  |            |
|                      |          |              |          |                  |            |

1. This message will be routed in the order shown, read and acted upon as necessary, and delivered to next Section promptly.
2. Carbon copy will be retained for filing by \_\_\_\_\_
3. Such extracts or paraphrases as are necessary will be made and filed by Sections concerned.
4. This slip will be returned to Deputy Comdr for Ops by \_\_\_\_\_ hours \_\_\_\_\_ 1000 with action attached or indicated hereon.

0 3 5 8

JJMP V JDPD NR 6 0

FROM JDPD 180254Z

TO JJMP

GR 218 BT

061117 F7-15

FLIGHT PLAN FOR FRANTIC SEVEN ON ONE EIGHT SEPTEMBER ONE NINE FOUR  
 FOUR PAREN DOGLITTLE TO WALSH SGD SPAATZ DOG SIX ONE ONE ONE SEVEN PAREN  
 SOUTHOLD FIVE FOUR ZERO ZERO SPACE ZERO FIVE ZERO ZERO SPACE ZERO  
 PLUS SIX TWO MIN FIVE FOUR TWO FIVE SPACE ZERO EIGHT FOUR ZERO SPACE  
 ZERO PLUS ONE ONE ZERO MIN FIVE FOUR FOUR THREE SPACE ONE ZERO ZERO  
 ZERO SPACE ZERO PLUS ONE TWO NINE MIN FIVE FOUR FIVE ZERO SPACE ONE  
 FIVE ZERO ZERO SPACE ZERO PLUS ONE NINE FOUR MIN FIVE FOUR TWO ZERO  
 SPACE ONE SIX ONE FIVE SPACE ZERO PLUS TWO ONE THREE MIN FIVE THREE  
 ONE SEVEN SPACE ONE EIGHT FOUR ZERO SPACE ZERO PLUS TWO SIX ZERO MIN  
 FIVE TWO FOUR ZERO SPACE ONE NINE FIVE ZERO SPACE ZERO PLUS TWO EIGHT  
 ONE MIN FIVE TWO THREE SIX SPACE TWO ZERO FIVE ZERO SPACE ZERO PLUS  
 TWO NINE FOUR MIN TARGET ZERO PLUS THREE ZERO THREE AT FOURTEEN  
 THOUSAND FT FIVE TWO TWO THREE SPACE TWO ONE THREE SIX SPACE ZERO PLUS  
 THREE ONE ONE MIN AT THIRTEEN THOUSAND FT FIVE ZERO ONE FIVE SPACE  
 THREE TWO TWO EIGHT SPACE ZERO PLUS FOUR NINE SIX MIN AT TWO THOUSAND  
 FT BASES AT ZERO PLUS FIVE THREE FIVE PD ZERO HOUR ZERO SEVEN THREE  
 ZERO BT RPT BT !

RECD 03470Z UWL

0900 PASTOR  
 0900 BST  
 0600 GAT

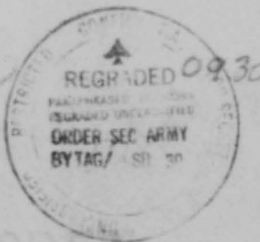

MCR 11



MESSAGE ROUTING SLIP  
From Deputy Comdr For Ops

|                |              |                |         |          |
|----------------|--------------|----------------|---------|----------|
| MESSAGE NUMBER | SENDER'S NO: | CLASSIFICATION |         |          |
| 43             | D61090       | Secret         |         |          |
|                | NCR NO:      |                |         |          |
|                | 3531         |                |         |          |
| ROUTED TO      | FOR ACTION   | FOR INFO       | COMMENT | INITIALS |
| Deputy         |              |                |         |          |
| CO for         | ✓            |                |         | H        |
| Ops            |              |                |         |          |
|                |              |                |         |          |
|                |              |                |         |          |
|                |              |                |         |          |
|                |              |                |         |          |
|                |              |                |         |          |
|                |              |                |         |          |
|                |              |                |         |          |
|                |              |                |         |          |
|                |              |                |         |          |
|                |              |                |         |          |
|                |              |                |         |          |
|                |              |                |         |          |
|                |              |                |         |          |
|                |              |                |         |          |

1. This message will be routed in the order shown, read and acted upon as necessary, and delivered to next Section promptly.
2. Carbon copy will be retained for filing by \_\_\_\_\_
3. Such extracts or paraphrases as are necessary will be made and filed by Sections concerned.
4. This slip will be returned to Deputy Comdr for Ops by \_\_\_\_\_ hours \_\_\_\_\_ 1944 with action attached or indicated hereon.

0360

SECRET  
URGENT

*Alps*

*P-12*

JBMP V JBPD NR 24 URGENT  
FROM JBAF 162255B SEPT 44  
TO JBPD  
JBMP

GR 47 BOUNCE BT

*D61090*  
FRANTIC SEVEN POSTPONED FOR TWENTY FOUR HOURS DUE TO ADVERSE  
WEATHER PAREN DOLXXX RPT DOOLITTLE TO TWINING AND WALSH SIGNED  
SPAATZ DOG SIX ONE ZERO NINE ZERO PAREN WILL NOT RPT WILL  
NOT BE EXECUTED ONE SEVEN SEPTEMBER

RECD CRYPTO 171031Z CEN

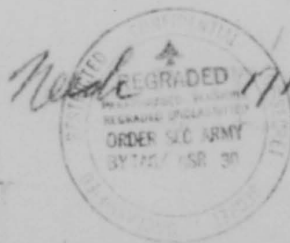

0361

MESSAGE ROUTING SLIP  
From Deputy Comdr For Ops

|                |              |                |         |          |
|----------------|--------------|----------------|---------|----------|
| MESSAGE NUMBER | SENDER'S NO: | CLASSIFICATION |         |          |
| 36             | U 68148      | Sec            |         |          |
|                | WCR NO: 3525 |                |         |          |
| ROUTED TO      | FOR ACTION   | FOR INFO       | COMMENT | INITIALS |
| Deputy Comdr   | ✓            |                |         | JH       |
|                |              |                |         |          |
|                |              |                |         |          |
|                |              |                |         |          |
|                |              |                |         |          |
|                |              |                |         |          |
|                |              |                |         |          |
|                |              |                |         |          |
|                |              |                |         |          |

1. This message will be routed in the order shown, read and acted upon as necessary, and delivered to next Section promptly.
2. Carbon copy will be retained for filing by \_\_\_\_\_
3. Such extracts or paraphrases as are necessary will be made and filed by Sections concerned.
4. This slip will be returned to Deputy Comdr for Ops by \_\_\_\_\_ hours \_\_\_\_\_ 1944 with action attached or indicated hereon.

0362

JEMP V JBPD NR 186 -0-

FROM JBPD 162305Z

TO JBMP

GR 47

BT

DUE TO ADVERSE WEATHER HAVE POSTPONED FRANTIC SEVEN FOR  
TWENTY FOUR HOURS PD TO WALSH SIGNED SPAATZ UNCLE SIX  
EIGHT ONE FOUR EIGHT CMA THIS IS PARAPHRASE OF DOG SIX  
ONE ZERO NINE ZERO SEPTEMBER SITEENTH PD ON SEVENTEEN  
SEPTEMBER OPERATION WILL NOT REPEAT NOT BE EXECUTED

CAUXUAXZKKIC

BT 2// 162312Z

SECRET

P-48

OPS  
CG

URGENT

068148

SECRET

Vacca

167337

RECD AT 2335Z VC VACCA

MCR 163

3525



0363

MESSAGE ROUTING SLIP  
From Deputy Comdr For Ops

|                    |              |                |         |          |
|--------------------|--------------|----------------|---------|----------|
| MESSAGE NUMBER     | SENDER'S NO: | CLASSIFICATION |         |          |
| 38                 | 261090       |                |         |          |
|                    | MCR NO:      |                |         |          |
|                    | 3528         |                |         |          |
| ROUTED TO          | FOR ACTION   | FOR INFO       | COMMENT | INITIALS |
| Deputy Com For Ops |              |                | noted   | H        |
|                    |              |                |         |          |
|                    |              |                |         |          |
|                    |              |                |         |          |
|                    |              |                |         |          |
|                    |              |                |         |          |
|                    |              |                |         |          |
|                    |              |                |         |          |
|                    |              |                |         |          |
|                    |              |                |         |          |

1. This message will be routed in the order shown, read and acted upon as necessary, and delivered to next Section promptly.
2. Carbon copy will be retained for filing by \_\_\_\_\_
3. Such extracts or paraphrases as are necessary will be made and filed by Sections concerned.
4. This slip will be returned to Deputy Comdr for Ops by \_\_\_\_\_ hours \_\_\_\_\_ 1944 with action attached or indicated hereon.

0364

SECRET

HEADQUARTERS  
EASTERN COMMAND  
USSTAF

INCOMING MESSAGE

|                |        |
|----------------|--------|
| PRECEDENCE     | URGENT |
| CLASSIFICATION | SECRET |

DATE \_\_\_\_\_ SERIAL NR. 061000

FROM: PINETREE T00:1622558

TO: POLTAVA RECD:162400Z

POSTPONED RPT POSTPONED FOR TWENTY FOUR HOURS DUE TO ADVERSE RPT  
ADVERSE WEATHER PAREN DOOLITTLE TO TWINING AND WALSH SIGNED SPAATZ  
DOG SIX ONE ZERO NINE ZERO PAREN WILL NOT RPT WILL NOT BE EXECUTED  
RPT EXECUTED ONE SEVEN SEPTEMBER PD QQQQ PD FRANTIC SEVEN

MCR 166



SECRET

THE MAKING OF AN EXACT COPY OF THIS MESSAGE IS FORBIDDEN. ONLY SUCH  
EXTRACTS AS ARE ABSOLUTELY NECESSARY WILL BE MADE AND PROPERLY  
CLASSIFIED.

0 3 6 5



NOTIFICATION FILE ..... OPERATIONS SECTION ..... DATE .....  
RADIO NO. 22222 FROM 1000 ..... TIME FILED .....  
TIME COPY .....  
NOTIFICATION AND TIME ..... TIME ..... METHOD ..... UNIT.

GENERAL FIDELITY .....  
C O LC .....  
MOODS .....  
AAF STATION 550 .....  
AAF STATION 550 .....  
AAF STATION 561 .....  
DEF CO FOR AAF .....  
COMMUNICATIONS .....  
INTELLIGENCE .....  
POSTED ON BOARD .....  
BASE OPERATIONS .....

0366

SECRET

JUMP V JSPD NR 56 URGENT

ops

FROM JSPD 161454Z

TO JUMP

DG1080

H

GR AB BOUNCE BT

MOVING ALL TIMES AHEAD THREE ZERO MINUTES AS YOU SUGGESTED FOR PAREN

DOLEWPT DOOLITTLE DOG SIX ONE ZERO EIGHT ZERO TO WALSH SCD SPAATZ

PAREN FRANTIC SEVEN PD WILL DEPART UK AT ZERO SIX THREE ZERO HOURS GMT

ONE SEVEN SEPTEMBER

BT 161502Z

3508

RECD 161507Z GFG

DECODED DATE 161512Z

RESTRICTED  
REGRADED  
BY: [unclear]  
DATE: [unclear]

SECRET

ucl  
107

0367



JEMP V JBPD NR 43 URGENT  
FROM JBPD 161248Z

TO JBMP

GR 28 BOUNCE BT

REQUEST OUR MOSQUITO WHICH

LANDED YOUR BASES BE HELD UNTIL OUR FRANTIC SEVEN PAREN

DOOLITTLE TO WALSH SGD SPAATZ DOG SIX ONE ZERO SEVEN FIVE PAREN

FORCES ARRIVE PD

NA

BT 161259Z

RECD 16/1300Z R Z R

*RZ4*  
SECRET

D61075

3505 DECODED BY *AD* DATE

SECRET

*F7*  
4  
161248Z  
16  
161248Z

0 2 3 0  
0 3 6 9

MESSAGE ROUTING SLIP  
From Deputy Comdr for Ops

|                   |        |              |          |                |     |
|-------------------|--------|--------------|----------|----------------|-----|
| MESSAGE NUMBER    | 21     | STANDARD NO: | D 61071  | CLASSIFICATION | Sec |
|                   |        | LCR NO:      | 3445     |                |     |
| ROUTED TO         | FOR    | FOR          | COL. NO. | INITIALS       |     |
|                   | ACTION | INFO         |          |                |     |
| Deputy CC for Ops | -      |              |          |                |     |
|                   |        |              |          |                |     |
|                   |        |              |          |                |     |
|                   |        |              |          |                |     |
|                   |        |              |          |                |     |
|                   |        |              |          |                |     |
|                   |        |              |          |                |     |
|                   |        |              |          |                |     |
|                   |        |              |          |                |     |
|                   |        |              |          |                |     |
|                   |        |              |          |                |     |

1. This message will be routed in the order shown, read and acted upon as necessary, and delivered to next Section promptly.
2. Carbon copy will be retained for filing by \_\_\_\_\_
3. Such extracts or paraphrases as are necessary will be made and filed by Sections concerned.
4. This slip will be returned to Deputy Comdr for Ops by \_\_\_\_\_ hours \_\_\_\_\_ 10th with action attached or indicated hereon.

0370

P-21

JUMP V JSPD NR 31 URGENT

FROM JSPD 161017Z

TO JUMP

JSPD

GR 123 BT

APPROXIMATE TIMINGS FOR FRANTIC

SEVEN FOR SEVENTEEN SEPTEMBER WILL DEPART UNITED KINGDOM ZERO  
 SEVEN ZERO ZERO GMT PD TIME OVER TARGET ONE ONE FIVE SEVEN GMT AT  
 FOURTEEN THOUSAND FEET CMA MIRGOROD ONE FIVE FOUR NINE GMT CMA AT  
 POLTAVA AT ONE SIX ONE ZERO GMT PD ONE MOSQUITO ABLE SLANT CHARLIE  
 WILL PROCEED BOMBERS SCOUTING WEATHER PAREN DOOLITTLE TO WALSH SGT  
 SPAATZ DOG SIX ONE ZERO SEVEN ONE PAREN AND LAND AT POLTAVA AT  
 APPROXIMATELY ONE THREE THREE ZERO PD FIGHTERS WILL LAND AT  
 PIRYATIAN AT APPROXIMATELY ONE FIVE ZERO FIVE GMT PD ALL  
 CALL SIGNS REMAIN SAME AS BEFORE PD REQUEST ALL NAVIGATION AIDS BE  
 IN OPERATION PD REQUEST INFORMATION ON MOSQUITO A/C DUE TO LAND AT  
 POLTAVA FIFTEEN SEPTEMBER PD

BT 161030Z

RECD AT 16/1037Z A C D

SECRET

Cape

1- Mosquito  
 GMT  
 Tgt 1157-1400  
 07-1549-AM  
 11610-PM  
 Fr-1505-PM

D61071



Handwritten signature and date: 1045

0371



JOMP V JOPD NR 53 URGENT  
FROM JOPD 141218Z  
TO JOMP  
FROM JDAF 151355B SEPT 4A  
TO JOPD  
JOMP

SECRET

C/S

GR 32 BOUNCE BY  
FRANTIC SEVEN WAS RETURNED TO UNCLE KING BASES PAREN DCCLITTLE  
TO WALSH SIGNED SPAATZ DOG SIX ONE ZERO SIX ZERO PAREN BECAUSE  
OF ADVERSE WEATHER CONDITIONS PD  
BT 151227

D 610601

RECD 151231Z ELO

DATE 151240Z

SECRET



0372

JBMP V JBPD NR 36 URGENT PETER 16  
FROM JBPD 150942Z  
TO JBMP  
JERL  
GR 42 BT

RADIO FLASH REPORT FROM FRANTIC MISSION SEVEN STATES THAT FORCE  
PAREN TO WALTH FROM SPAATZ UNCLE XRAY SIX EIGHT ZERO SIX FIVE  
PAREN TURNED BACK BETWEEN ZERO SEVEN FIVE EIGHT ZEBRA AND ZERO  
EIGHT FOUR EIGHT ZEBRA DUE TO ADVERSE WEATHER

BT 151000Z  
RECD....151007Z ELO



MESSAGE ROUTING SLIP  
From Deputy Comdr For Ops

|                |              |                |         |          |
|----------------|--------------|----------------|---------|----------|
| MESSAGE NUMBER | SENDER'S NO: | CLASSIFICATION |         |          |
| 904            | DL1051       | Secret         |         |          |
|                | MCR NO:      |                |         |          |
|                | 3451         |                |         |          |
| ROUTED TO      | FOR ACTION   | FOR INFO       | COMMENT | INITIALS |
| Deputy         | ✓            |                |         | H        |
| CO for         |              |                |         |          |
| Ops            |              |                |         |          |
|                |              |                |         |          |
|                |              |                |         |          |
|                |              |                |         |          |
|                |              |                |         |          |
|                |              |                |         |          |
|                |              |                |         |          |
|                |              |                |         |          |
|                |              |                |         |          |
|                |              |                |         |          |
|                |              |                |         |          |
|                |              |                |         |          |
|                |              |                |         |          |
|                |              |                |         |          |
|                |              |                |         |          |
|                |              |                |         |          |
|                |              |                |         |          |
|                |              |                |         |          |
|                |              |                |         |          |
|                |              |                |         |          |
|                |              |                |         |          |

1. This message will be routed in the order shown, read and acted upon as necessary, and delivered to next Section promptly.
2. Carbon copy will be retained for filing by \_\_\_\_\_
3. Such extracts or paraphrases as are necessary will be made and filed by Sections concerned.
4. This slip will be returned to Deputy Comdr for Ops by \_\_\_\_\_ hours \_\_\_\_\_ 1944 with action attached or indicated hereon.

7 2 8 9  
0 3 7 4

HEADQUARTERS  
EASTERN COMMAND  
USSTAF  
INCOMING MESSAGE

OPS  
CB  
F-7  
H

|                |        |
|----------------|--------|
| PRECEDENCE     | URGENT |
| CLASSIFICATION | SECRET |

DATE 150131E

**URGENT**

SERIAL NR. D 61051

FROM: DOOLITTLE

TO: WALSH

NEW TIMINGS FOR FRONTIER BOYER FOR ONE FIVE SEPT PD WILU DRPNRT  
 UNCLE KING ZERO SEVEN ZERO ZERO GMT CMA CINE XXX OVNJ TKRRET  
 ONE ONE FIVE NINE GMT AT FOURTEEN THOUSAND FEET CMJ MINGROD  
 ONE FIVE ZERO EIGHT GMT AND FIVE AT ONE FIVE TWO EIGHT  
 GMT PD ONE MOSQUITO AIRCRAFT WILL PROCEED BO BERS CMA SCOUTING  
 WEATHER CMA AND LAND AT POLTAVI AT APPART ONE THREE THREE ZERO  
 GMT PD FIGHTERS WILL PAREN TO DOOLITTLE TO WALSH SGD SPAATZ DOG  
 SIX ONE ZERO FIVE ONE SECRET PAREN LAND AT PIRYATIAN AT APPROX  
 ONE FOUR THREE THREE GMT PD ALL CASL SIGNS REMAIN SAME AS BEFORE

1153 Tot  
1453 Local

1433 2000  
1733 4000 - ARRIVE

CRYPTOGRAPHED  
BY \_\_\_\_\_  
DATE \_\_\_\_\_  
TIME \_\_\_\_\_



THE MAKING OF AN EXACT COPY OF THIS MESSAGE IS FORBIDDEN. ONLY SUCH  
EXTRACTS AS ARE ABSOLUTELY NECESSARY WILL BE MADE AND PROPERLY  
CLASSIFIED.

0375

MESSAGE ROUTING SLIP  
From Deputy Comdr For Ops

|                   |              |                |         |          |
|-------------------|--------------|----------------|---------|----------|
| MESSAGE NUMBER    | SENDER'S NO: | CLASSIFICATION |         |          |
| 903               | 061049       | Secret         |         |          |
|                   | MCR NO:      |                |         |          |
|                   | 3436         |                |         |          |
| ROUTED TO         | FOR ACTION   | FOR INFO       | COMMENT | INITIALS |
| Deputy CO for Ops | ✓            |                |         | HC       |
|                   |              |                |         |          |
|                   |              |                |         |          |
|                   |              |                |         |          |
|                   |              |                |         |          |
|                   |              |                |         |          |
|                   |              |                |         |          |
|                   |              |                |         |          |
|                   |              |                |         |          |
|                   |              |                |         |          |
|                   |              |                |         |          |
|                   |              |                |         |          |
|                   |              |                |         |          |
|                   |              |                |         |          |
|                   |              |                |         |          |

1. This message will be routed in the order shown, read and acted upon as necessary, and delivered to next Section promptly.
2. Carbon copy will be retained for filing by \_\_\_\_\_
3. Such extracts or paraphrases as are necessary will be made and filed by Sections concerned.
4. This slip will be returned to Deputy Comdr for Ops by \_\_\_\_\_ hours \_\_\_\_\_ 1944 with action attached or indicated hereon.

0376

HEADQUARTERS  
EASTERN COMMAND  
USSTAF  
INCOMING MESSAGE

ops  
CG  
18

|                |        |
|----------------|--------|
| PRECEDENCE     | URGENT |
| CLASSIFICATION | SECRET |

URGENT

F-7

DATE 150210Z

SERIAL NR. D 61049

FROM: DOOLITTLE

TO: WALSH

DUE TO WEATHER PAREN TO EAKER AND TRAINING FRD DOOLITTLE SIGNED  
SPAATZ DOG SIX ONE ZEROFOUR NINE PASSED BY MAAF TO WALSH PAREN  
THE BODY REPORT ONLY OPERATION PLANNED FOR ONE FIVE SEPTS IS  
FRANTIC SEVEN IN AREA OF GEORGE YOKE FOUR EIGHT SEVEN USUR

CRYPTOGRAPHED

BY \_\_\_\_\_  
DATE \_\_\_\_\_  
TIME \_\_\_\_\_

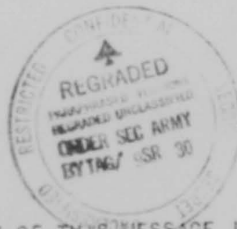

THE MAKING OF AN EXACT COPY OF THIS MESSAGE IS FORBIDDEN. ONLY SUCH  
EXTRACTS AS ARE ABSOLUTELY NECESSARY WILL BE MADE AND PROPERLY  
CLASSIFIED.

0 3 7 7



JEMP V JJUL 141300 OPERATIONAL PRIORITY  
 FROM JJCS 141734B  
 TO JEMP

JJUL

CRST BOUNCE BT

VIAFE2034A

FRANTIC SIX NOT DEPARTING ITALY ONE FIVE SEPTEMBER PD WE WILL BE  
 ABLE TO PAREN TO CG, EASTERN CMD L CG, AAF/ATO FROM TWINING  
 CITE IV AF EASY TWO ZERO THREE FOUR A SECRET BOUNCE PAREN  
 ACCOMMODATE FRANTIC SEVEN ANYWAY PD AIRCRAFT ON FRANTIC SEVEN  
 SHOULD BE BRIEFED TO LAND AT THE FOLLOWING DATES COLON BOMBERS  
 SHOULD BE DIVIDED EQUALLY IN FOLLOWING SIX LOCATIONS COLON <sup>18</sup>STERAPARONE  
 PAREN FOUR ONE THREE SIX CMA ONE FIVE ONE EIGHT PAREN CMA <sup>18</sup>CELOME PAREN  
 FOUR ONE THREE THREE CMA ONE FIVE THREE THREE PAREN CMA <sup>18</sup>LUCERA  
 PAREN FOUR ONE THREE ZERO CMA ONE FIVE TWO FIVE PAREN CMA <sup>18</sup>TORTORELLA  
 PAREN FOUR ONE TWO NINE CMA ONE FIVE THREE NINE PAREN CMA AND  
 AMENDOLA RPT <sup>36</sup>AMENDOLA PAREN FOUR ONE THREE TWO CMA ONE FIVE FOUR TWO  
 PAREN PD AMENDOLA IS A DOUBLE FIELD AND SHOULD BE CONSIDERED AT  
 TWO FIELDS FOR THE DISPERSAL OF FRANTIC SEVEN PD FIGHTERS SHOULD  
 LAND TWO SQUADRONS AT <sup>32</sup>SAN SEVERO PAREN FOUR ONE FOUR TWO CMA  
 ONE FIVE TWO FIVE PAREN CMA ONE SQUADRON AT <sup>16</sup>LECINA PAREN FOUR ONE  
 FIVE ONE CMA ONE FIVE ONE EIGHT PAREN CMA WITH FOURTH SQUADRON CMA  
 IF ANY CMA AT <sup>16</sup>MADNA PAREN FOUR ONE FIVE TWO CMA ONE FIVE ZERO FOUR  
 PAREN

BT 141734B

RECD 1642 Z UWL



0378

JEMP V JEPD NR 66 "URGENT" "QED" SECRET  
FROM JEPD 141618Z  
TO JEMP  
GR 62 DT

DG1045

(OP)

COAST AT ZERO SEVEN ZERO ZERO GMT ONE FIVE SEPTEMBER WEATHER  
PERMITTING MA RPT CMA UNLESS NOTIFIED OTHERWISE BY YOUR HEAD-  
QUARTERS PD 000000 PD PLAN TO EXECUTE PARDN DOGLITTLE TO WALSH  
FGD SPAANA DOG SIX ONE ZERO FOUR FIVE PARDN FRANTIC SEVEN WITH  
ONE ZERO EIGHT REPEAT ONE ZERO EIGHT BOMBERS AND SIX FOUR PETER  
FIVE ONZO PD WILL DEPART ENGLISH

BT 141627

RECD 141630Z CFC

344

REGRADED  
GREEN SFC ARMY  
BYTAG/MSR 30

114

DECLASSIFIED BY 538 DATE 141635Z  
SECRET

0379

SECRET 041

P-7  
 JBMP V JBPD NR 11 U R G E N T  
 FROM JBPD 140612Z  
 FROM JBAF 140550B SEPT 44  
 TO JBPD  
 JBMP  
 GR 36 BOUNCE BT  
 FLIGHT PLAN FOR FIFTEEN SEPTEMBER PD QQQQ PD FRANTIC SEVEN  
 WILL NOT REPEAT NOT BE EXECUTED FOURTEEN SEPT ONE NINE FOUR FOUR  
 PAREN DOOLITTLE TO WALSH CGD SPAATZ DOG SIX ONE ZERO TWO NINE  
 PAREN REQUEST APPROVAL OF SAME  
 BT 140627Z  
 RECD AT 14/0828Z A C D

061029

3437

RECEIVED  
 MESSAGE CENTER  
 ORT  
 BY

SECRET

DENIED BY *acd* DATE 0835

0 3 8 0

MESSAGE ROUTING SLIP  
From Deputy Comdr for Ops

|                               |                     |                         |
|-------------------------------|---------------------|-------------------------|
| MESSAGE NUMBER : 880          | STANDARD NO: D61025 | CLASSIFICATION : Secret |
| GROUP NO: 3433                |                     |                         |
| ROUTED TO : Deputy CC for Ops | FOR ACTION : ✓      | FOR INFO : F7-file      |
|                               |                     | INITIALS : HC           |
|                               |                     |                         |
|                               |                     |                         |
|                               |                     |                         |
|                               |                     |                         |
|                               |                     |                         |
|                               |                     |                         |
|                               |                     |                         |
|                               |                     |                         |
|                               |                     |                         |
|                               |                     |                         |
|                               |                     |                         |
|                               |                     |                         |

1. This message will be routed in the order shown, read and acted upon as necessary, and delivered to next Section promptly.
2. Carbon copy will be retained for filing by \_\_\_\_\_
3. Such extracts or paraphrases as are necessary will be made and filed by Sections concerned.
4. This slip will be returned to Deputy Comdr for Ops by \_\_\_\_\_ hours \_\_\_\_\_ 10th with action attached or indicated hereon.

0381

JEMP V JBAF NR 1A URGENT  
FROM JBAF 140230D SEPT 44  
TO JDDP  
JEMP

**SECRET**  
D610231  
**URGENT**  
F-7  
P-1 Ops  
#6

CR 282 BT BOUNCE BT PART ONE OF TWO PARTS

0 + 3  
ROUTED AND TIMING FOR FRANTIC SEVEN CLN SOUTH WOLD ZERO PLUS THREE  
THREE CMA <sup>2</sup> <sup>6</sup> <sup>0</sup> <sup>0</sup> ZERO ZERO ZERO FEET CLN <sup>5</sup> <sup>4</sup> FIVE FOUR ZERO ZERO DASH ZERO  
FIVE ZERO <sup>0</sup> <sup>0</sup> ZERO CMA PLUS <sup>9</sup> <sup>9</sup> NINE NINE CLN <sup>5</sup> <sup>4</sup> FIVE FOUR THREE FOUR DASH ZERO  
EIGHT THREE TWO CMA PLUS ONE FOUR THREE CMA ONE SIX ZERO ZERO ZERO  
FEET CLN FIVE FOUR FOUR ZERO DASH ONE ZERO ZERO ZERO CMA PLUS ONE  
ONE CLN FIVE FOUR FIVE ZERO DASH ONE FOUR ZERO ZERO CMA PLUS  
TWO ZERO ZERO CLN FIVE FOUR TWO ZERO DASH ONE SIX ONE FIVE CMA PLUS  
TWO THREE THREE CMA ONE SIX ZERO ZERO ZERO CLN FIVE THREE ONE SEVEN  
DASH ONE EIGHT FOUR ZERO CMA PLUS TWO SIX SEVEN CLN FIVE TWO FOUR  
ZERO DASH ONE NINE FIVE ZERO CMA PLUS TWO EIGHT FIVE CMA ONE FOUR ZERO  
ZERO ZERO FEET CLN FIVE TWO THREE SIX DASH TWO ZERO FIVE ZERO CMA PLUS  
TWO NINE EIGHT CMA ONE FOUR ZERO ZERO ZERO CLN TARGET CMA PLUS THREE  
ZERO SIX CMA ONE FOUR ZERO ZERO ZERO CLN FIVE TWO TWO THREE DASH TWO  
ONE THREE SIX CMA PLUS THREE ONE FIVE CMA ONE FOUR ZERO ZERO ZERO FE  
ET DPT FEET CLN FIVE ZERO ONE FIVE DASH THREE TWO TWO NINE CMA PLUS  
FOUR SIX FIVE CMA FIVE ZERO ZERO ZERO FEET CLN DASH CMA PLUS FOUR  
NINE FIVE CMA FIVE ZERO ZERO ZERO PAREN DOGLITTLE TO WALSH SIGNED  
OPATZ DCG SIX ONE ZERO TWO THREE PAREN CALL SIGN TO BE USED CLN  
BOMBER LEADER W/T TRAY GEORGE YONE CMA R/T WAKEDC PD ALL OTHER BOMBERS  
USE STATION AIRCRAFT CALL SIGN FIGHTER LEADER R/T UNCLE SQUADRONS  
CLN FALCON CMA CUSTARD CMA BENTLEY CMA BORAX PD REQUEST ALL NAVIGAT-  
IONAL AID BE TURNED ON FOR USE PD ZERO FOUR ZERO EIGHT THREE ZERO  
FOUR DDOT

BT 140137Z KD  
RPT  
RCD AT 140400Z R Z R

3422  
**SECRET**

FROM JJCC 132020B

TO JUMP

GR OR BT

SECRET

R-2-  
URGENT

F  
ON OPERATIONS OF ONE THREE SEPTEMBER CMA COLONEL CHARLES ABLE  
CLARK AND CREW OF NINE LAST PAREN TO CG, EAST COND FROM TWINING  
CITE WAF EAST DASH TWO ZERO ONE ONE PAREN REPORTED HEADED  
TOWARD LNOV PD DID HE LAND IN RUSSIAN TERRITORY QUERY IF CG  
REQUEST HE BE TRANSPORTED TO POLTOVA WHERE TRANSPORTATION BACK TO  
ITALY WILL BE ARRANGE

BT 132020B

RECD AT 140528Z R Z R

435  
T760  
A  
DEC 27 1952

DATE 140527Z

0383



JEMIP V JDPD NR 24 OP  
FROM JDPD 130255Z  
TO JJHL  
INFO JEMIP  
PNT

① Ops for info  
② File

GR 84 BT

PART ONE OF TWO PARTS

CLZARED BY RUSSIANS IS FRANTIR SEVEN WHICH LEAVES FROM WERE PD ONE  
ZERO ZERO BAKER ONESEVENS APPROX SIX FOUR FIGHTERS PD TOPSEC EAKER

~~INFO DOOLITTLE WALSHE SGAATZ UNCLE KRAY SIX SEVEN NI NE SIX NINE~~

INFO DOOLITTLE WALSHE SGAATZ UNCLE KRAY SIX SEVEN NI NE SIX NINE  
PD

PART TWO

OPERATION INVOLVES DROPPING SUPPLIES TO WARSAW PD CAN YOU HANDLE  
THIS FORCE AT YOUR BASES APPROX ONE FIVE SEPT PD FRANTIC SIX RPT SIX  
SHOULD BE COMING YOUR WAY TODAY PD NO FURTHER FRANTIC MIDXXX  
MISSIONS CONTEMPLATED PD DESIREOUS OF HAVING FRANTIC SDVEN CLEAR  
EASTCON BASES VER XXX VERY RAPIDLY

No reply  
[Signature]

BT 130237Z

RECD 130250Z

3409  
NO GRADED  
ORDER SGT ARMY  
BYTAG/USP

~~[Redacted]~~

0384

HEADQUARTERS  
EASTERN COMMAND  
USSTAF  
INCOMING MESSAGE

071

|                |                   |
|----------------|-------------------|
| PRECEDENCE     | URGENT            |
| CLASSIFICATION | <del>SECRET</del> |

~~SECRET~~

DATE 13 0015Z

SERIAL NR. M 20945

FROM: JARR

TO: POLTAVA 130105Z

THAT INSTRUCTIONS HAVE BEEN ISSUED APPROVING THE PLAN PD  
K K K K K WALSH FROM DEANE TOPSEC MIKE TWO ZERO NINE FOUR FIVE PD  
IN REGARD TO TODAY'S PLAN GENERAL ANTONOV SAYS

*answered by T-713*

3403

CRYPTOGRAPHED  
BY *Bushy*  
DATE *13*  
TIME *0138*

~~SECRET~~

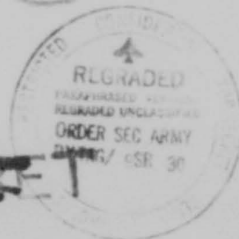

THE MAKING OF AN EXACT COPY OF THIS MESSAGE IS FORBIDDEN. ONLY SUCH  
EXTRACTS AS ARE ABSOLUTELY NECESSARY WILL BE MADE AND PROPERLY  
CLASSIFIED.

0385

R-12

JEMP V JBPD NR 195 URGENT

FROM JBPD 121753Z

TO JBMP

GR 36 BT

FRANTIC SEVEN WILL NOT RPT NOT BE ECKX EXECUTED THIRTEEN SEPT ONE  
NINE FOUR FOUR PAREN DOOLITTLE TO WALSH SGT SPAATZ DOG SIX ZERO  
NINE EIGHT SIX PAREN REQUEST APPROVAL OF SAME FLIGHT PLAN FOR  
FOURTEEN SEPTEMBER

RECD 121814Z RBK

DG0986

Merck 12/8 212



JMMP V JDPD NR 26 URGENT

FROM JDPD121159Z

TO JMMP

GR 223 BT

PROPOSED PLAN FOR FRANTIC SEVEN PAREN DOOLITTLE TO WALSH SGD SPAATZ

DOG SIX ZERO NINE SEVEN THREE PAREN IS AS FOLLOWS CONON

ONE HUNDRED BAKER ONE SEVEN AND SIXTY FOUR PETER FIVE ONES DEPART

ENGLISH COAST AT ZERO SIX ZERO ZERO GMT SEMICOLON

FIVE FOUR ZERO ZERO DASH ZERO FIVE ZERO ZERO CMA ZERO SIX FIVE

FIVE GMT

FIVE FOUR THREE FOUR DASH ZERO EIGHT THREE TWO CMA ZERO SEVEN

FOUR FIVE GMT SEMICOLON

FIVE FOUR FOUR ZERO DASH ONE ZERO ZERO ZERO CMA ZERO EIGHT

ZERO FIVE GMT SEMICOLON

FIVE FOUR FIVE ZERO DASH ONE FOUR ZERO ZERO CMA ZERO NINE ZERO

ZERO GMT SEMICOLON

FIVE TWO FIVE THREE DASH TWO ZERO ZERO FIVE CMA ONE ZERO THREE

FIVE GMT SEMICOLON

FIVE TWO TWO THREE DASH TWO ZERO ONE TWO CMA ONE ZERO FOUR FIVE

GMT SEMICOLON

TARGET GEORGE YOKE DASH FOUR EIGHT SEVEN FOUR CMA ONE ZERO FIVE

FIVE ONE ZERO GMT CMA ONE ZERO ZERO ZERO ZERO FEET SEMICOLON

FIVE TWO TWO SEVEN DASH TWO ONE ONE NINE CMA ONE ONE ZERO FIVE GMT  
SEMICOLON

FIVE ZERO ONE FIVE DASH THREE TWO TWO NINE CMA ONE FOUR ZERO FIVE LVT

DMIC

D

SEMICOLON  
LRM BAKES CMA ONE FOUR TWO ZERO PD

T-PB

REQUEST LATEST AVAILABLE INFORMATION ON AA DEFENSES IN TARGET AREA

BE OBTAINED FROM WALSH AND TRANSMISSION TO THIS HQS BE EXPEDITED

RECD 1205Z WVL

260973



0387

JEMP V JBPD NR 25 0

FROM JBPD 120844Z

TO JEMP

INFO JJUL

GR 37 BT

ALMOST IMMEDIATELY COMES FLIGHT PLAN FRANTIC SEVEN FROM EIGHTH AIR  
FORCE INVOLVING SUPPLIES TO WARSAW FOR EXECUTION ONE THREE SEPT  
PD TORSEC WALSH SGT SPAATZ UNCLE XRAY SIX SEVEN NINE ONE TWO PD  
STRENGTH ONE HUNDRED BOMBERS

IAW02VPS3

RECD AT 120913Z VACCA



120913Z  
MCR 56  
121951Z

0 3 8 8

#383

NOTIFICATION SLIP OPERATIONS SECTION DATE 23/8

RADIO NO. SWP63E FROM 0244 TIME FILED 1745

TIME REPLY

NOTIFICATION AND TIME

| NAME               | TITLE | METHOD | UNIT |
|--------------------|-------|--------|------|
| GENERAL PHAMINOV   |       |        |      |
| C G EC             |       |        |      |
| 105000             |       |        |      |
| AAF STATION 550    |       |        |      |
| AAF STATION 560    |       |        |      |
| AAF STATION 561    |       |        |      |
| DEP CO FOR AIR     |       |        |      |
| COMMUNICATIONS     |       |        |      |
| INTELLIGENCE       |       |        |      |
| POSTED ON BOARD    |       |        |      |
| BASE OPERATIONS    |       |        |      |
| <i>Col Hampton</i> |       |        |      |
|                    |       |        |      |

*7/8*

*Callahan*

0389



SECRET

R.15  
Gm

JUMP V JJHL NR R138 OPERATIONAL PARIOTY QED  
FROM JJHL 231535  
TO J.M.  
GR66 BT

JW84JE

SPARTZ ADVISES ONE FIVE AIR FORCE NOT REPEAT NOT (PAREN  
TO TWINING (R) WALSH EAKER CITE JIG WILLIAM EIGHT SIX  
ITEM EASY NT 46 ITEM EASY PAREN) LIKELY TO BE CALLED  
UPON FOR SHUTTLE BEFORE EARLY SEPTEN ER CMA ALSO  
THAT DISCUSSION OF ADVANCED FIGHTER SERVICING FIELDS CAN  
BE HELD TWO FIVE AUGUST AT CASERTA WHEN ALL OF HIS  
INTERESTED PARTIES WILL BE PRESENT

RECD 231402Z HEER



me R94  
231415Z

DECODED BY [signature] DATE 231411Z

0390

HEADQUARTERS EASTERN COMMAND USSTAF  
 INCOMING MESSAGE

SECRET

|                |                       |            |       |
|----------------|-----------------------|------------|-------|
| PRIORITY       | URGENT                | ACTION:    |       |
| CLASSIFICATION | <del>TOP SECRET</del> |            | INFO: |
| DATE/TIME      | 211535B               |            |       |
| FROM:          | CASERTA               |            |       |
| TO:            | POLTAVA               |            |       |
| SERIAL NR:     | IE1594                | RETURN BY: |       |

PERSONNEL MENTIONED IN OUR XR RPT IE FIVE EIGHT FIVE NT RPT NT  
 NEED NOT RPT NOT BE SENT BY OPERATIONAL AIRCRAFT PAREN TO EAKER  
 FOR WALSH FROM TRAINING CITE XE ONE FIVE NINE FOUR NT TOPSECRET  
 PAREN THEY WILL ACCOMPANY THE TASK FORCE ITSELF PD THEY WILL  
 NOT RPT NOT EXCEED ONE PER EACH BOMBARDMENT AIRCRAFT SENT OY  
 MISSION BUT THE NUMBER MAY EXCEED THE NUMBER MENTIONED IN OUR  
 IE ONE FIVE EIGHT FIVE NT PT THIS REFERS TO MAINTENANCE PERSONNEL

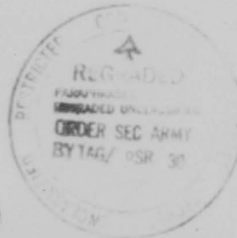

CRYPTOGRAPHED

DATE \_\_\_\_\_  
 TIME \_\_\_\_\_

ACTION TAKEN:

THE MAKING OF AN EXACT COPY OF THIS MESSAGE IS FORBIDDEN. ONLY SUCH EXTRACTS AS  
 ARE ABSOLUTELY NECESSARY WILL BE MADE AND PROPERLY CLASSIFIED.

0391

~~TOP SECRET~~

COR

JUNNY

MMMP V JEL NR R146 U R G E N T QED

211757B

GR 158 BY

SH

JW 831E

R-8-

FUTURE FRANTIC OPERATIONS PAREN TOPSECRET TO PAATZ CITE  
 CHARLIE SUGAR SIX ONE ITEMS EASY CMA REPEATED TO WALSH CITE  
 JIG WILLIAM EIGHT THREE ITEM EASY FROM EAKER PAREN IS  
 SUBJECT PD EYE CONCUR IN FOLLOWING FROM TUNING QUOTE  
 REALIZE IT IS IMPOSSIBLE AT PRESENT TO SECURE ADDITIONAL  
 ADVANCE BASES WEST OF POLTAVA AREA PD HOWEVER BELIEVE IT  
 ESSENTIAL THAT WE SECURE PERMISSION FROM THE RUSSIANS FOR  
 THE USE OF ONE OR PREFERABLY TWO ADVANCED AIRDROMES IN  
 AN AREA GENERALLY WEST OF KIEV PD THESE ADVANCED  
 FIELDS WILL BE USED FOR SERVICING FIGHTER AIRCRAFT AND  
 FOR BOMBERS IN EMERGENCY LANDINGS ONLY PD FIGHTERS CAN  
 BE BRIEFED AT AND TAKE OFF FROM REGULAR BASES CMA COMPLETE  
 ASSIGNED MISSION AND LAND AT THESE ADVANCE FIELDS FOR FUEL  
 CMA RETURNING TO REGULAR BASE THE SAME DAY PD THIS DUE TO  
 EXTREME RANGE AND INADEQUATE HOUEING FACILITIES AT  
 EASTERN BASES UNQUOTE RECOMMEND NO FRANTIC BY FIFTEENTH AIR  
 FORCE UNTIL AFTER TWENTY SEVEN AUGUST BECAUSE POSSIBLE NEED  
 BATTLE ITALY END

CVM

BY 211757B

RECD AT 211646Z

R Z R

2705

~~SECRET~~

RESTRICTED  
 HLG  
 AUTHORIZED  
 PERSONNEL ONLY  
 1961

DECODED BY RZ DATE 211655Z

0392

URGENT

JMP V JJ-L NR 02000 URGENT QED  
 FROM JJCO 211000  
 TO JMP  
 CR 187 BT

1E1592CS1258NT

THE AIR FORCE PREPARED TO EXECUTE FRANTIC SEVEN WHEN DESIRED  
 PD THREE ALTERNATE ROUTES AVAILABLE COLON NORTH CMA CENTRAL AND  
 SOUTH PD TANK FORCE TARGETS AS FOLLOWS COLON NORTHERN ROUTE  
 TARGETS DOBRIN AND MORAVKA OTRAVA PLANT PRIVOC OIL REFINERIES  
 CMA CENTRAL ROUTE TARGET DELJ OIL REFINERY CMA SOUTHERN ROUTE TARGETS  
 MOJEN TI AND DANJICIL SARAY OIL REFINERIES PD REMAINDER OF AIR  
 FORCE WILL SUPPORT TANK FORCE EFFORT WITH ATTACKS ON OTHER  
 TARGETS IN SAME VICINITY PD TANK FORCE PREPARED TO ATTACK  
 KOSICEBINS PLANT JACAU AIRBORNE FROM EASTERN BATES CMA OR ANY  
 OTHER TARGET WITH IN RANGE UPON WHICH TARGET MATERIAL CAN BE  
 PROVIDED PD AS OF NOW ALL NECESSARY PERSONNEL AND SUPPLIES CAN  
 BE DELIVERED BY OPERATIONAL AIRCRAFT PD ADDITIONAL SUPPLY  
 (PARACHUTE) TO LAND FOR WALK CMA DEPART FROM TRAINING SITE REDLINE  
 ITEM FIVE ONE FIVE ONE TWO CMA CHARLIE TUGAR ONE TWO FIVE EIGHT  
 HAS MORE TOP TARGET PARACHUTE EQUIPMENT MAY BE REQUIRED DEPENDENT UPON  
 DEPLETION OF EXISTING SUPPLIES AT EASTERN COMMAND BY FRANTIC SIX

URGENT

ALG 301  
 HEADQUARTERS  
 ORDER SEC ARMY

DECODED BY SPB DATE 211225

0393

~~SECRET~~ SECRET

JEMP V JJML NR R42 URGENT QED  
FROM JJCC 201700B  
TO JBMP  
GR--- BT  
SM

R-16

1E1585NT

TOP SECRET PD PLANNING TO CARRY ON FRANTIC SEVEN BY OPERATIONAL  
BOMBER THE FOLLOWING OPERATIONAL AND PAREN REDLINE TO EAKER FOR  
WALSH FROM TWINING CITE IE ONE FIVE EIGHT FIVE NT TOP SECRET  
PAREN MAINTENANCE PERSONNEL CLN THREE MUSTANG SQUADRON LINE  
CHIEFS CMA TWELVE FORTRESS GROUP MAINTENANCE STAFF CMA FIVE  
GROUP INTELLIGENCE PERSONNEL CMA SEVEN TASK FORCE STAFF  
PERSONNEL PD INFORMATION AVAILABLE HERE INDICATES NO OTHER  
OPERATIONS ARE ~~REQUIRE~~

3-151  
12-817  
5-11-1952  
in supply

and by one T-276

MAINTENANCE PERSONNEL AND NO RPT NO SUPPLIES  
OR EQUIPMENT NEED BE SENT FROM ITALY PD REQUEST YOUR  
CONFIRMATION THAT OUR INFORMATION ACCURATE

2300-2400  
H

2681

BT 201700B

RECD 201850Z

PAR



MCR 117  
2019032

12/24/1952

03094

EXTRACT FROM UX66316 JBDP

Red No. 2414.

JBMP V JBDP NR 41 OPERATIONAL PRIORITY

FROM JBDP 121310Z

TO JBAF

INFOR JEHHL

JBMP

GR 116 BT

\* \* \* ~~SECRET~~ DOOLITTLE INFO EAKER WALSH SOD SPAATZ UNCLE XRAY SIX SIX  
THREE ONE SIX CITE UNCLE XRAY SIX TWO THREE EIGHT AUGUST ONE ONE PD \* \* \*  
CONTEMPLATE FRANTIC SEVEN WILL BE RUN BY FIFTEENTH AIR FORCE BETWEEN TWO  
FIVE AUGUST ONE SEPT \* \* \* \*

0395



HEADQUARTERS EASTERN COMMAND, U.S. STRATEGIC AIR FORCES IN EUROPE  
 MIGRATING MESSAGE

|                                   |                          |                          |
|-----------------------------------|--------------------------|--------------------------|
| PRECEDENCE<br><b>OPS PRIORITY</b> | DECLASSIFIED<br>NO 11832 | DEP. CHIEF'S<br>INITIALS |
| CLASSIFICATION                    |                          | ORIGINATOR               |
| DATE<br>24 SEPT 44                |                          | DEPUTY CHIEF FOR OPS     |
| SERIAL NR<br>1042                 |                          | DEPT CHIEF'S<br>INITIALS |
|                                   |                          | TIME CLRD.               |

TO:

DEPARTED AT ZERO SIX ZERO ZERO ZEBRA FROM ESCOM TEN BAKER SEVENTEENS  
 FOR ITALY PAREN BAKER FOR TRAINING INFO SPAATZ FOR DOOLITTLE TARE  
 1-42 PAREN AND <sup>EIGHT</sup> PETER FIVE ONES AT ZERO SEVEN ZERO ZERO  
 ZEBRA IN ACCORDANCE WITH PLAN

|                                |                                   |
|--------------------------------|-----------------------------------|
| RETURN TO                      | 522. 312-1<br>44/09/00 - 44/09/00 |
| AFSHHC<br>MAXWELL AFB TX 36112 |                                   |

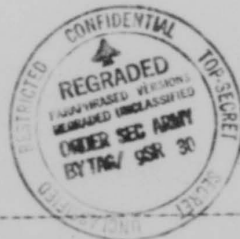

DECLASSIFIED  
NO 11832

1029154

REFERENCES:

THE MAKING OF AN EXACT COPY OF THIS MESSAGE IS FORBIDDEN. ONLY SUCH  
 EXTRACTS AS ARE ABSOLUTELY NECESSARY WILL BE MADE AND PROPERLY  
 CLASSIFIED

0396

SECRET

HEADQUARTERS  
EASTERN COMMAND  
U S STRATEGIC AIR FORCES IN EUROPE

23 September 1944.

My Dear General Perminov.

General Spaatz has requested that we send to Italy as soon as possible all operational Mustangs and Fortresses. We now have ready to go a force of 8 Mustangs and 12 Fortresses. These aircraft will not carry bombs and will procede to Italy according to the following plan.

FLIGHT PLAN

|                  |            |              |   |            |
|------------------|------------|--------------|---|------------|
| Take Off Poltava | 0900 hours | Moscow time. |   |            |
| ODESSA           | 1056 hours | "            | " |            |
| BUCURESTI        | 1227 hours | "            | " | 20,000 ft. |
| SOPIYA           | 1327 hours | "            | " |            |
| Italian Bases    | 1615 hours | "            | " |            |

The Mustangs will join the Fortresses at Bucuresti 1227 hours Moscow time 20,000 ft and escort them to Italy.

Sincerely,

WILLIAM A. SULLIVAN Jr,  
Lt. Colonel, Air Corps,  
Deputy Comdr for Ops.

SECRET



0 3 9 7

SECRET

HEADQUARTERS  
EASTERN COMMAND  
U S STRATEGIC AIR FORCES IN EUROPE

23 SEPTEMBER 44.

FIELD ORDER )

NO. SPECIAL )

1. 8 P-51'S WILL JOIN THE BOMBERS AT 20,000 FEET AT 1227 MOSCOW  
TIME SOUTH OF BUCURESTI.

2. NO TARGETS WILL BE ATTACK.

3. A. FORCE - 11 B-17S.

B. ASSEMBLY - 6,000 FEET OVER POLTAVA.

C. ROUTE.

|                |            |            |
|----------------|------------|------------|
| POLTAVA        | 6,000 FT.  | 0920 HOURS |
| ODESSA         | 6,000 FT.  | 1056 HOURS |
| BUCURESTI      | 20,000 FT. | 1227 HOURS |
| SOFIYA         |            | 1327 HOURS |
| BRINDISI       |            | 1530 HOURS |
| BASES (LUCERA) |            | 1615 HOURS |

ALL TIMES ARE MOSCOW TIME.

X. (1) ZERO HOUR 0900 MOSCOW TIME 24 SEPT 44.

(2) NO BOMB LOAD.

(3) GAS LOAD 2700 GALS.

4. NORMAL.

SECRET

- 1 -



0398

SECRET

## 5. COMMUNICATIONS.

A. ROCOGNITION:ALLIED  
GMT

|               | FLARE | CHALLENGE | ANSWER |
|---------------|-------|-----------|--------|
| 0001Z - 0600Z | G-Y   | X         | Z      |
| 0601Z - 1200Z | R-Y   | Q         | C      |
| 1201Z - 1800Z | G-Y   | L         | Y      |
| 1801Z - 2400Z | G-G   | H         | D      |

RUSSIAN

CHALLENGE - DIP RIGHT WING 3 TO 5 TIMES.  
ANSWER - ROCK WINGS 3 TO 5 TIMES.

## B. VHF CALL SIGNS:

BOMBERS: VING GROVE 1.

FIGHTERS: BALANCE 1.

## C. VHF CODE WORDS:

AUTHENTICATION - RED HEAD  
RECALL - HOMESICK  
INDIVIDUAL ABORT - LONESOME

## D. D/F VERIFICATION: SD 0220 CARD 367.

E. BUNCHER BEACONS: POLTAVA - C/S WX FREQ 1510 KC  
MIRGOROD - C/S DC FREQ 1710 KC  
IN OPERATION FROM 0300Z TO 1800Z.F. IFF INFORMATION

IFF WILL BE TURNED ON AT TAKE OFF: OFF WHEN CROSSING  
THE FRONT LINES AND TURNED BACK ON WHEN CROSSING THE  
YUGOSLAV COAST AND TURNED OFF UPON LANDING.

G. MESSAGE TO ITALIAN STATIONS WILL BE SENT **TM** CLEAR ONLY  
IN EMERGENCY.H. BOMBER BASE

LUCERA - 301ST B.G.  
AIRDROME CONTROL - LONGSKIRT 116.1 MEGS AND 6440 KC(DAY ONLY)  
RADIO BEACON - RA 219 KC (REQUEST TO 42N-6530-W/T) DAY ONLY.

SECRET

- 2 -

0 3 9 9

SECRET

## 5. H. (CONTD)

FIGHTER BASE

SAN SEVERO - 31ST F.G.  
 AIRDROME CONTROL - GRACIE 116.1 MEGS AND 6440 KC (DAY ONLY).

I. EMERGENCY LANDING FIELDS

VIS - (43<sup>0</sup>02'00"N 16<sup>0</sup>12'00"E)  
 AIRDROME CONTROL - TOP SAIL 116.1 MEGS (DAY ONLY).  
 VHF SECTOR CONTROL - TOP SAIL 116.1 MEGS  
 VHF HOMER - FORTELL 116.1 MEGS (REQUEST TO TOP SAIL)

J. NAVIGATIONAL AIDS

VHF FIXING SYSTEM - 41<sup>0</sup>05'N 16<sup>0</sup>16'E - BIG FENCE ON 116.1  
 MEGS AND 126.18 MEGS  
 (DAY ONLY).

K. RADIO RANGE - WITH 2 MARKER BEACON

FOGGIA - (41<sup>0</sup>31'10"N 15<sup>0</sup>33'10"E)  
 CALL SIGN - FO ON FREQUENCY 263 KC.  
 CONTINUOUS BY DAY - REQUEST 841 ON 3560 KC BY NIGHT  
 MAGNETIC COURSES TO STATION: 85<sup>0</sup>, A, 151<sup>0</sup>, N, 265<sup>0</sup>, A,  
 331<sup>0</sup>, N.  
 6.25 MILES FROM A/D ON 198 MAG.

WILLIAM A. SULLIVAN, JR,  
 LT. COL., AIR CORPS,  
 DEPUTY COMDR FOR OPS.

SECRET

-3-

0400

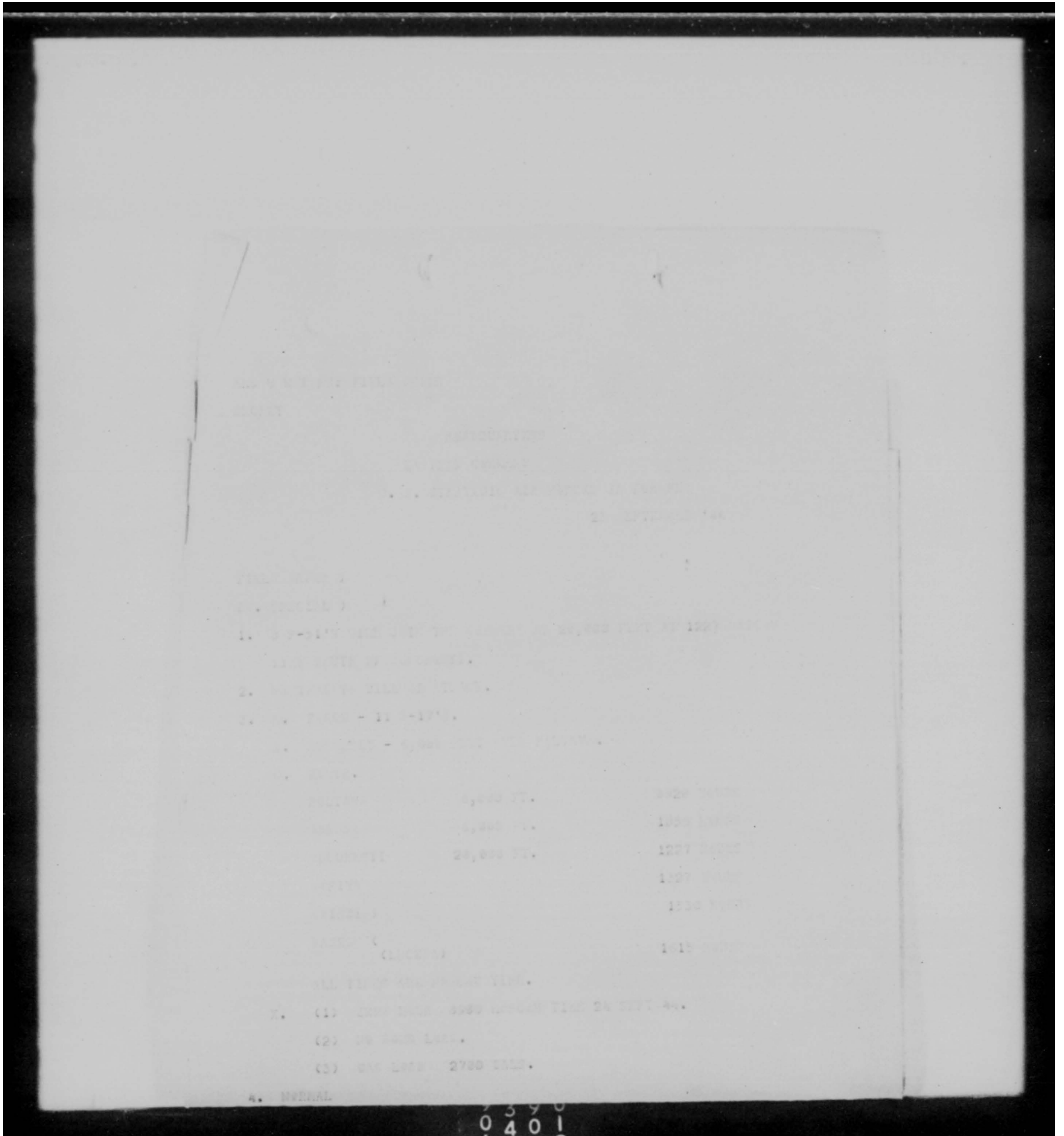



2. 1. PACE - 11 2-178.

2. BOSTON - 5,000 FT. W. 7-178.

3. BOSTON.

BOSTON 4,000 FT.

1020 1000

BOSTON 3,000 FT.

1010 1000

BOSTON 20,000 FT.

1000 1000

BOSTON

1000 1000

BOSTON

1000 1000

BOSTON (CINCINNATI)

1010 1000

ALL THESE ARE SUBJECT TO.

1. (1) THE 1000 2000 1000 24 1000 00.

(2) THE 1000 1000.

(3) THE 1000 2000 0000.

4. BOSTON

5. BOSTON.

6. BOSTON

BOSTON

BOSTON

FLAME

CHALLENGE

ANSWER

1001 - 1000

1-1

1

1001 - 1000

1-1

1

1001 - 1000

1-1

1

1001 - 2000

1-1

1

BOSTON

CHALLENGE - 1000 1000 1 TO 1 1000.

CHALLENGE - 1000 1000 1 TO 1 1000.

1000 1000

1000 1000 1.

1000 1000 1.

1000 1000

1000 1000 - 1000

1000 - 1000

1000 1000 - 1000

1000 1000 1000 1000 1000.

1000 1000 1000 1000 - 1000 1000 1000

1000 1000 - 1000 1000 1000 1000

1000 1000 1000 1000 1000.

F. IFF INFORMATION

0 4 0 2

1. THE SOUTH OF ...

- 2. ...
- 3. ...

FINANCIAL BALANCE 1.

4. ...

INTERMEDIATE - ...

SMALL - ...

INDIVIDUAL ...

5. ...

6. ...

... 1718 ...

IN OPERATION FROM ...

7. ...

... WILL BE ...

THE ...

... WILL BE ...

8. ...

... IN EMERGENCY.

9. ...

... 301ST ...

... 110.1 ...

... 210 ...

10. ...

... 11 T ...

... 11 T ...

... 110.1 ...

1. ...

... 10 ...

... 12 ...

... 110.1 ...

... 110.1 ...

... 110.1 ...

11. ...

... 15 ...

... 110.1 ...

... 120.1 ...

... 120.1 ...

...

0403



HEADQUARTERS EASTERN COMMAND, U.S. STRATEGIC AIR FORCES IN EUROPE  
 C I T I N G M E S S A G E

|                   |                      |
|-------------------|----------------------|
| PRECEDENCE        | DEF. CMDR'S INITIALS |
| URGENT            | ORIGINATOR           |
| CLASSIFICATION    | OPERATIONS           |
| SECRET            | DATE                 |
| DATE              | INITIALS             |
| 23 SEPTEMBER 1944 | TIME CLRD.           |
| SERIAL NR         |                      |
| 71024             |                      |

TO: \_\_\_\_\_

CONTEMPLATE SENDING ONE TWO FORTRESSES AND EIGHT MUSTANGS TO ITALY  
 TWO FOUR SEPTEMBER<sup>PD</sup> ROUTE AS FOLLOWS COLON PAREN SPAATZ CMA EAKER  
 AND TWINING FROM WALSH TARE 1024 PAREN  
 DEPART ESCOM AT ZERO SIX TWO ZERO ZEBRA CMA BUCURESTI TWO ZERO ZERO  
 ZERO ZERO FEET AT ZERO NINE TWO SEVEN ZEBRA CMA SOFIA AT ONE ZERO  
 TWO SEVEN ZEBRA CMA BRINDISI AT ONE TWO THREE ZERO ZEBRA CMA LAND  
 BASE LUCERA AT ONE THREE ONE FIVE ZEBRA PD NO REPEAT NO BOMB LOAD  
 PD FIGHTER RENDEVOUS BUCUREST TWENTY THOUSAND FEET PD FIGHTERS WILL  
 LAND SAN SEVERO RW WEATHER PBRMITTING



REFERENCES: \_\_\_\_\_

THE MAKING OF AN EXACT COPY OF THIS MESSAGE IS FORBIDDEN. ONLY SUCH  
 EXTRACTS AS ARE ABSOLUTELY NECESSARY WILL BE MADE AND PROPERLY  
 CLASSIFIED

0405

HEADQUARTERS  
EASTERN COMMAND  
U S STRATEGIC AIR FORCES IN EUROPE

20 SEPTEMBER 1944

MY DEAR COLONEL TORGMAN:

BECAUSE OF IMPROPER BRIEFING IN ENGLAND THE CREWS ON THE  
MISSION WHICH ARRIVED HERE SEPTEMBER 18 DID NOT KNOW WHICH BEACONS  
WERE OPERATING. NONE OF THE BEACONS WERE USED.

SINCERELY

RALPH E. WILSON,  
CAPTAIN, AIR CORPS,  
OPERATIONS OFFICER.

7 3 9 9  
0 4 0 6

HEADQUARTERS EASTERN COMMAND, U.S. STRATEGIC AIR FORCES IN EUROPE  
 OUTGOING MESSAGE

|                |                   |
|----------------|-------------------|
| PRECEDENCE     | OPS PRIORITY      |
| CLASSIFICATION | SECRET            |
| DATE           | 21 SEPTEMBER 1944 |
| SERIAL NR      | T                 |

|                           |
|---------------------------|
| DEP. CHIEF'S<br>INITIALS  |
| ORIGINATOR<br>OPERATIONS  |
| DEPT. CHIEF'S<br>INITIALS |
| TIME CLRD.                |

TO: \_\_\_\_\_

WE ARE ADVISED BY THE SOVIETS THAT ONE FORTRESS OF INCOMING FRANTIC  
 SEVEN LANDED SAFELY AT BREST LITOVSK PD PAREN SPAATZ FOR DOOLITTLE CMA  
 EAKER FOR TWINING CMA INFO DEANE FOR WALSH FROM KESSLER SIGNED WALSH  
 TARE \_\_\_\_\_ PAREN AIRCRAFT AND CREW IS EXPECTED  
 TO ARRIVE EASTCOM BASES TODAY PD CREW NAMES AND AIRCRAFT NUMBER UNKNOWN

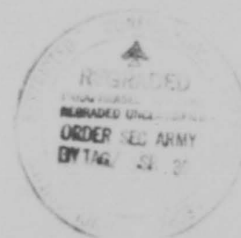

7-963  
 REFERENCES: \_\_\_\_\_

THE MAKING OF AN EXACT COPY OF THIS MESSAGE IS FORBIDDEN. ONLY SUCH  
 EXTRACTS AS ARE ABSOLUTELY NECESSARY WILL BE MADE AND PROPERLY  
 CLASSIFIED.

0407



HEADQUARTERS EASTERN COMMAND, U.S. STRATEGIC AIR FORCES IN EUROPE  
 OUTGOING MESSAGE

PRECEDENCE  
 OPS PRIORITY  
 CLASSIFICATION  
 SECRET  
 DATE  
 20 SEPT  
 SERIAL NR  
 T 956

DEP. CMDR'S  
 INITIALS  
 ORIGINATOR  
 DUTY O'S  
 INITIALS  
 TIME CLRD.

TO: PIRYATIN

SEVEN

DISPATCH YOUR ~~P-51~~ PETER FIVE ONES VIA ODESSA TO ITALY TOMORROW

RE PAREN REEHER FROM KESSLER TARE 956 PAREN

T O ~~2000~~ ONE SEPTEMBER AT EIGHT HUNDRED HOURS PD THEY ARE CLEARED

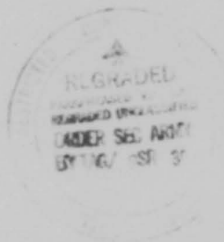

REFERENCES:

THE MAKING OF AN EXACT COPY OF THIS MESSAGE IS FORBIDDEN. ONLY SUCH  
 EXTRACTS AS ARE ABSOLUTELY NECESSARY WILL BE MADE AND PROPERLY  
 CLASSIFIED

0408

HEADQUARTERS EASTERN COMMAND, U.S. STRATEGIC AIR FORCES IN EUROPE  
 OUTGOING MESSAGE

|                |                   |
|----------------|-------------------|
| PRECEDENCE     | OP PRIORITY       |
| CLASSIFICATION | CONFIDENTIAL      |
| DATE           | 20 SEPTEMBER 1944 |
| SERIAL NR      |                   |

|                            |
|----------------------------|
| DEP. CMDR'S<br>INITIALS    |
| ORIGINATOR<br>OPERATIONS   |
| DUTY OFFICER'S<br>INITIALS |
| TIME GRD.                  |

TO: RCM

CONFIRMING VOOG THIS DATE ALL AVAILABLE MUSTANGS WILL PROCEED TO  
 ITALY VIA ODESSA AT 25,000 PD TAKE OFF IS DESIRED CLEARED WITH THE  
 RUSSIANS FOR 0800 PD WEATHER AT ITALIAN BASES QUESTIONABLE <sup>CM</sup> LATE FORECAST  
 WILL FOLLOW



REFERENCES:

THE MAKING OF AN EXACT COPY OF THIS MESSAGE IS FORBIDDEN. ONLY SUCH  
 EXTRACTS AS ARE ABSOLUTELY NECESSARY WILL BE MADE AND PROPERLY

0409

HEADQUARTERS EASTERN COMMAND, U.S. STRATEGIC AIR FORCES IN EUROPE  
 SWIFT MESSAGE

PRECEDENCE  
 OPS PRIORITY  
 CLASSIFICATION  
 SECRET  
 DATE  
 19 SEPTEMBER 1944  
 SERIAL NR  
 T 929

DEP. CHIEF'S  
 INITIALS  
 ORIGINATOR  
 OPERATIONS  
 DIVISION  
 INITIALS  
 TIME GRD.

TO: JHML, JBDP, JBRB

RETURNED SAFELY TO POLTAVA PAREN EAKER FOR TWINING CMA SPAATZ FOR  
 DOOLITTLE CMA INFO DEANE FOR WALSH FROM KESSLER SIGNED WALSH TARE  
 PAREN FORTRESS TWO THREE ONE EIGHT EIGHT  
 SEVEN CMA MECHANICAL TROUBLE PD FINAL SCORE NINE TWO FORTS AND FIVE  
 FIVE MUSTANGS OUTBOUND



REFERENCES:

THE MAKING OF AN EXACT COPY OF THIS MESSAGE IS FORBIDDEN. ONLY SUCH  
 EXTRACTS AS ARE ABSOLUTELY NECESSARY WILL BE MADE AND PROPERLY  
 CLASSIFIED

0410

HEADQUARTERS EASTERN COMMAND, U.S. STRATEGIC AIR FORCES IN EUROPE  
 MISSING MESSAGE

|                              |                          |
|------------------------------|--------------------------|
| PRECEDENCE<br>OPS PRIORITY   | DEP. CHIEF'S<br>INITIALS |
| CLASSIFICATION<br>TOP SECRET | ORIGINATOR<br>OPERATIONS |
| DATE<br>19 SEPTEMBER 1944    | INITIALS                 |
| SERIAL NR<br>T               | TIME CORD.               |

TO: JBPD, JHML, JMBDE

NOTE OUR TARE NINE ONE FOUR AND CHANGE NUMBER OF MUSTANGS TO FIVE  
 FIVE PD PAREN SPATZ FOR DOOLITTLE CMA EAKER FOR TWING CMA INFO  
 DEANE FOR WALSH FROM KESSLER SIGNED WALSH TOP SECRET TAPE \_\_\_\_\_  
 \_\_\_\_\_ PAREN CAPT & CARNEY IN FOX FIVE THREE EIGHT NINE  
 DEPARTED AT ONE ONE TWO THREE ZEBRA WILL MAKE BDA ENROUTE

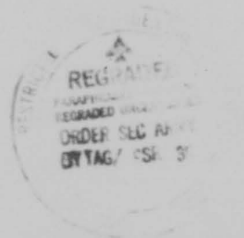

T 919

REFERENCES:

THE MAKING OF AN EXACT COPY OF THIS MESSAGE IS FORBIDDEN. ONLY SUCH  
 EXTRACTS AS ARE ABSOLUTELY NECESSARY WILL BE MADE AND PROPERLY  
 CLASSIFIED

0411

HEADQUARTERS EASTERN COMMAND, U.S. STRATEGIC AIR FORCES IN EUROPE  
 CONTINUING MESSAGE

PRECEDENCE URGENT  
 CLASSIFICATION ~~SECRET~~  
 DATE 19 SEPTEMBER 1944  
 SERIAL NR T

DEP. CMDR'S  
 INITIALS  
 OPERATIONS  
 DIVISION  
 INITIALS  
 TIME CLRD.

TO: JJHL, JBPD, JMRB

BOUND FOR ITALIAN BASES ARE PAREN TO SPAATZ FOR DOOLITTLE CMA EAKER  
 FOR TWINING CMA INFO DEANE FOR WALSH FROM KESSLER SIGNED WALSH TOP  
 SECRET TARE \_\_\_\_\_ PAREN NINE THREE FORTRESSES  
 CMA FIVE SEVEN MUSTANGS CMA TWO MOSQUITOS PD ONE FOX FIVE ETD ONE ONE  
 ZERO ZERO ZEBRA FOR BDA PD ETA BASES ONE FOUR THREE ZERO ZEBRA OK

RESTRICTED  
 REGRADE  
 ORDER SEC 4411  
 BYTAG/

REFERENCES:

THE MAKING OF AN EXACT COPY OF THIS MESSAGE IS FORBIDDEN. ONLY SUCH  
 EXTRACTS AS ARE ABSOLUTELY NECESSARY WILL BE MADE AND PROPERLY  
 CLASSIFIED

0412

SECRET

HEADQUARTERS  
EASTERN COMMAND  
U S STRATEGIC AIR FORCES IN EUROPE

19 September 1944.

My Dear General Perminov.

Francis 7 Mission to Russia has been completed with moderate success. It is estimated that approximately 50 % of the supplies landed in the dropping zone.

WILLIAM A. SULLIVAN, Jr  
Lt Colonel, AG.  
Deputy Commander for Ops.

*Delivered 1130, 19 Sept 44  
by W/O [Signature]*

SECRET



0413



ALL INFORMATION CONTAINED HEREIN IS UNCLASSIFIED EXCEPT WHERE SHOWN OTHERWISE BY THIS NOTICE.

SECRET  
EXCLUDED FROM AUTOMATIC DOWNGRADING AND  
DECLASSIFICATION

SECRET - 15 PAGES IN TOTAL

15 SEPTEMBER 1944.

PAGE NO. 1

PAGE NO. 1

1. THE INTELLIGENCE AGENT.

(1) PRIMARY SOURCE.

ALL INFORMATION CONTAINED HEREIN IS UNCLASSIFIED EXCEPT WHERE SHOWN OTHERWISE BY THIS NOTICE.

2. THE AGENT.

(1) PRIMARY SOURCE.  
SECRET NO. 12-20-44

12-20-44

12-20-44 - [unclear] [unclear] [unclear] 12-20-44  
12-20-44 - [unclear] [unclear] [unclear]  
12-20-44 - [unclear] [unclear] [unclear]  
12-20-44 - [unclear] [unclear] [unclear]  
(ALL INFORMATION CONTAINED HEREIN IS UNCLASSIFIED EXCEPT WHERE SHOWN OTHERWISE BY THIS NOTICE.)

12-20-44

12-20-44 - [unclear] [unclear] [unclear] 12-20-44  
12-20-44 - [unclear] [unclear] [unclear] [unclear] [unclear]  
12-20-44 - [unclear] [unclear] [unclear] [unclear] [unclear]  
12-20-44 - [unclear] [unclear] [unclear] [unclear] [unclear]  
(ALL INFORMATION CONTAINED HEREIN IS UNCLASSIFIED EXCEPT WHERE SHOWN OTHERWISE BY THIS NOTICE.)

12-20-44

12-20-44 - [unclear] [unclear] [unclear] 12-20-44  
12-20-44 - [unclear] [unclear] [unclear] [unclear] [unclear]  
12-20-44 - [unclear] [unclear] [unclear] [unclear] [unclear]  
12-20-44 - [unclear] [unclear] [unclear] [unclear] [unclear]  
(ALL INFORMATION CONTAINED HEREIN IS UNCLASSIFIED EXCEPT WHERE SHOWN OTHERWISE BY THIS NOTICE.)

(2) PRIMARY SOURCE.  
SECRET NO. 12-18-44

PAGE NO. 2 OF 15, SECRET

303  
0414



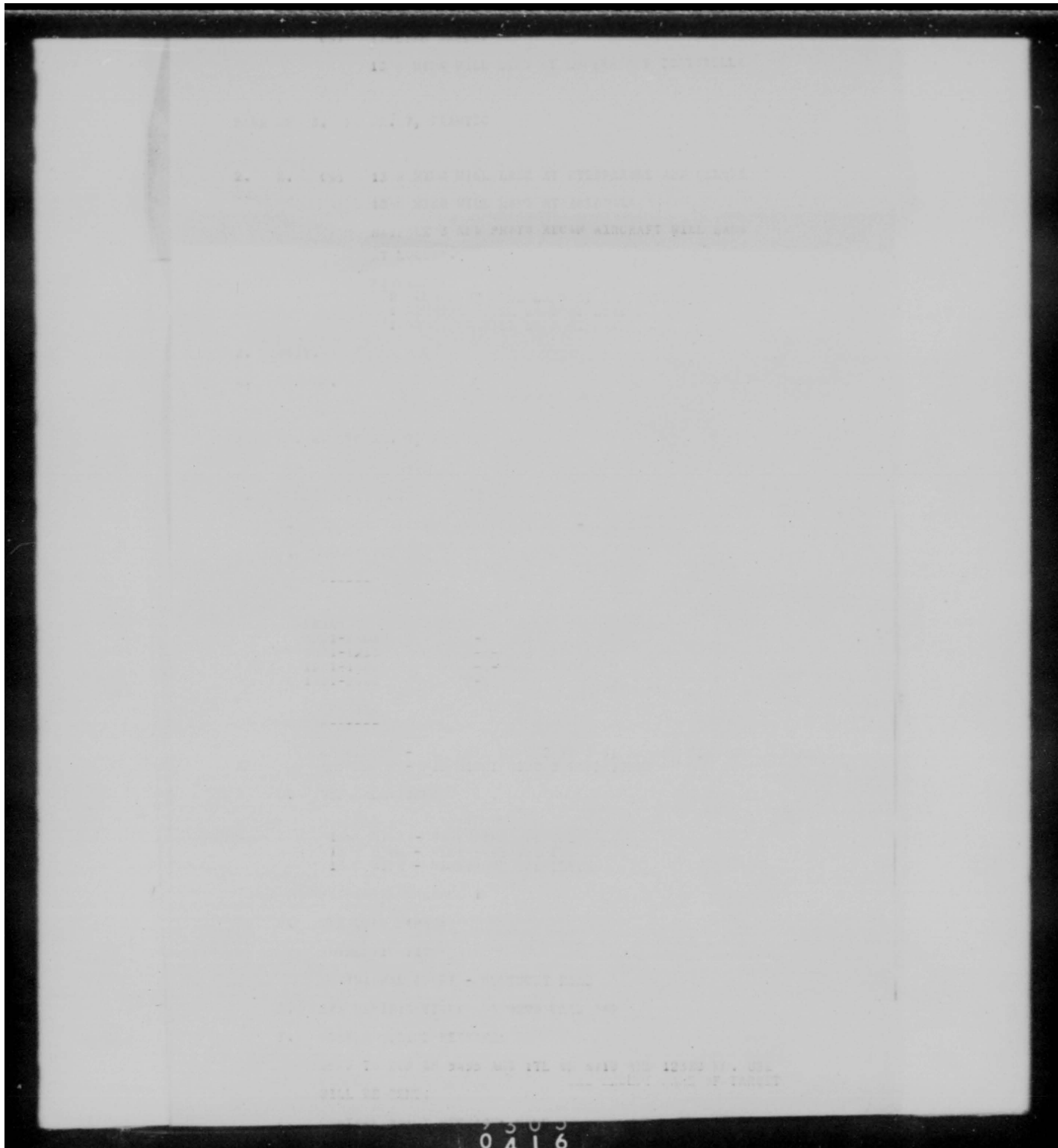

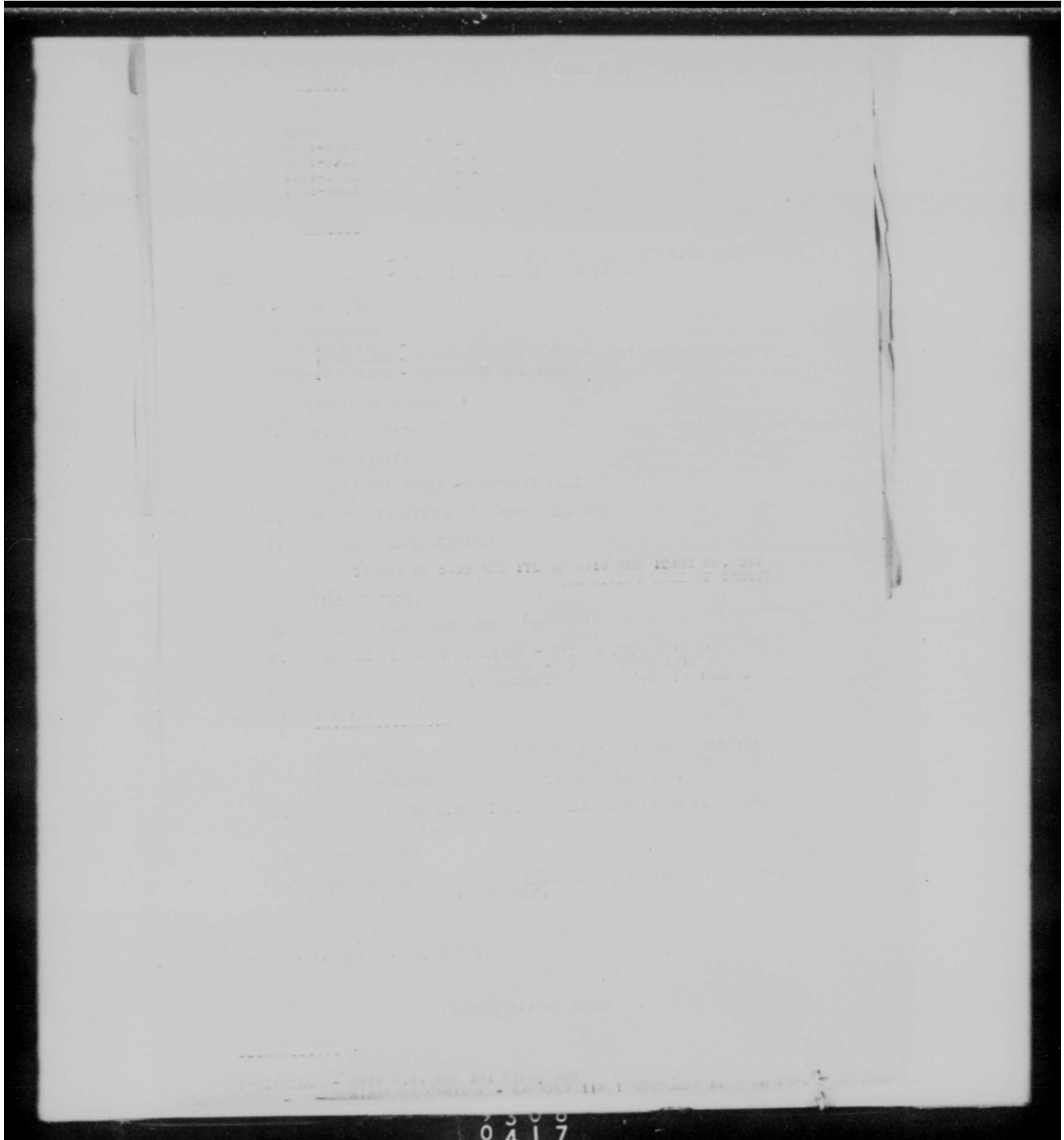

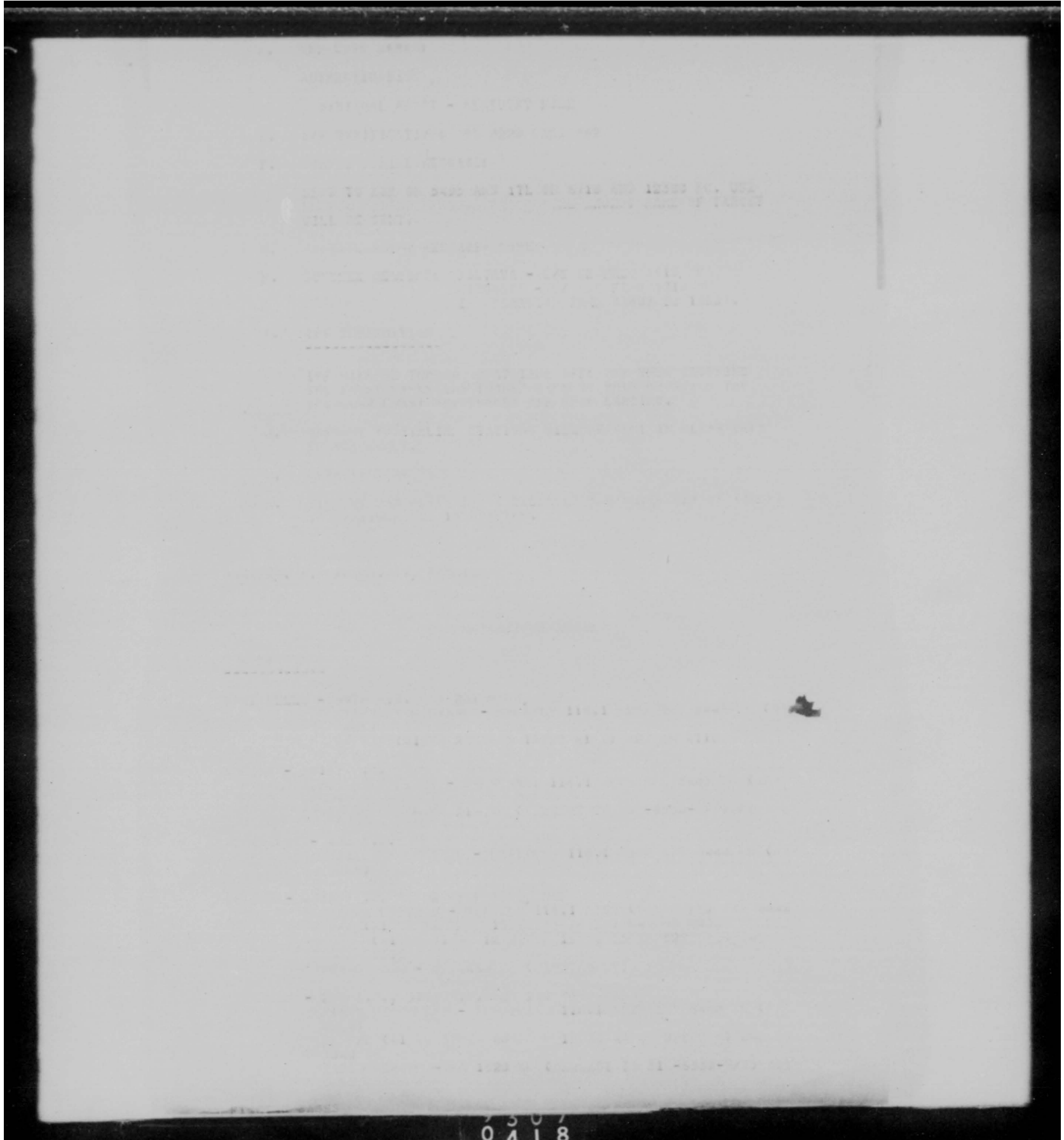

THIS PAGE IS DECLASSIFIED IAW EO 13526

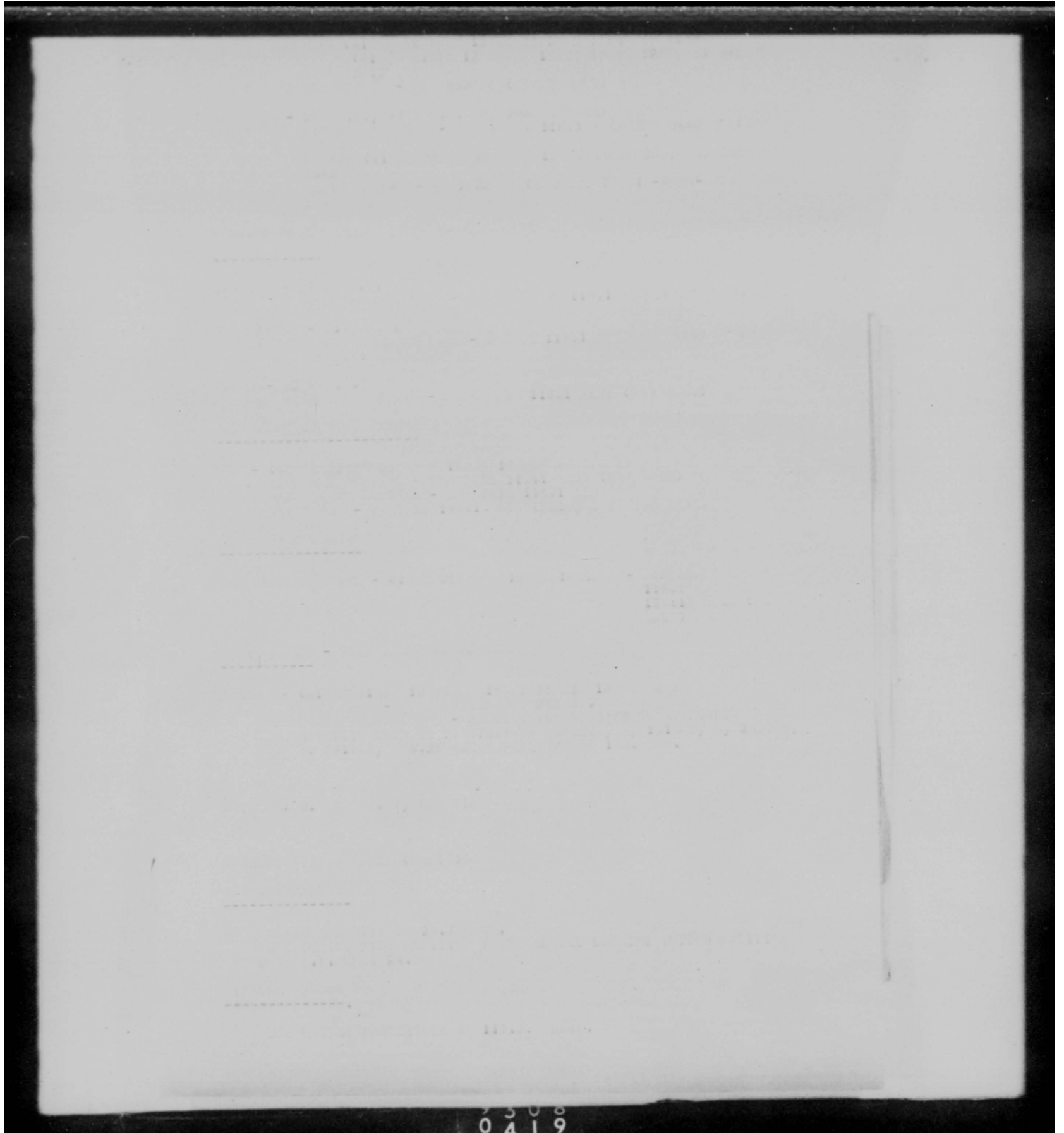

THIS PAGE IS DECLASSIFIED IAW EO 13526



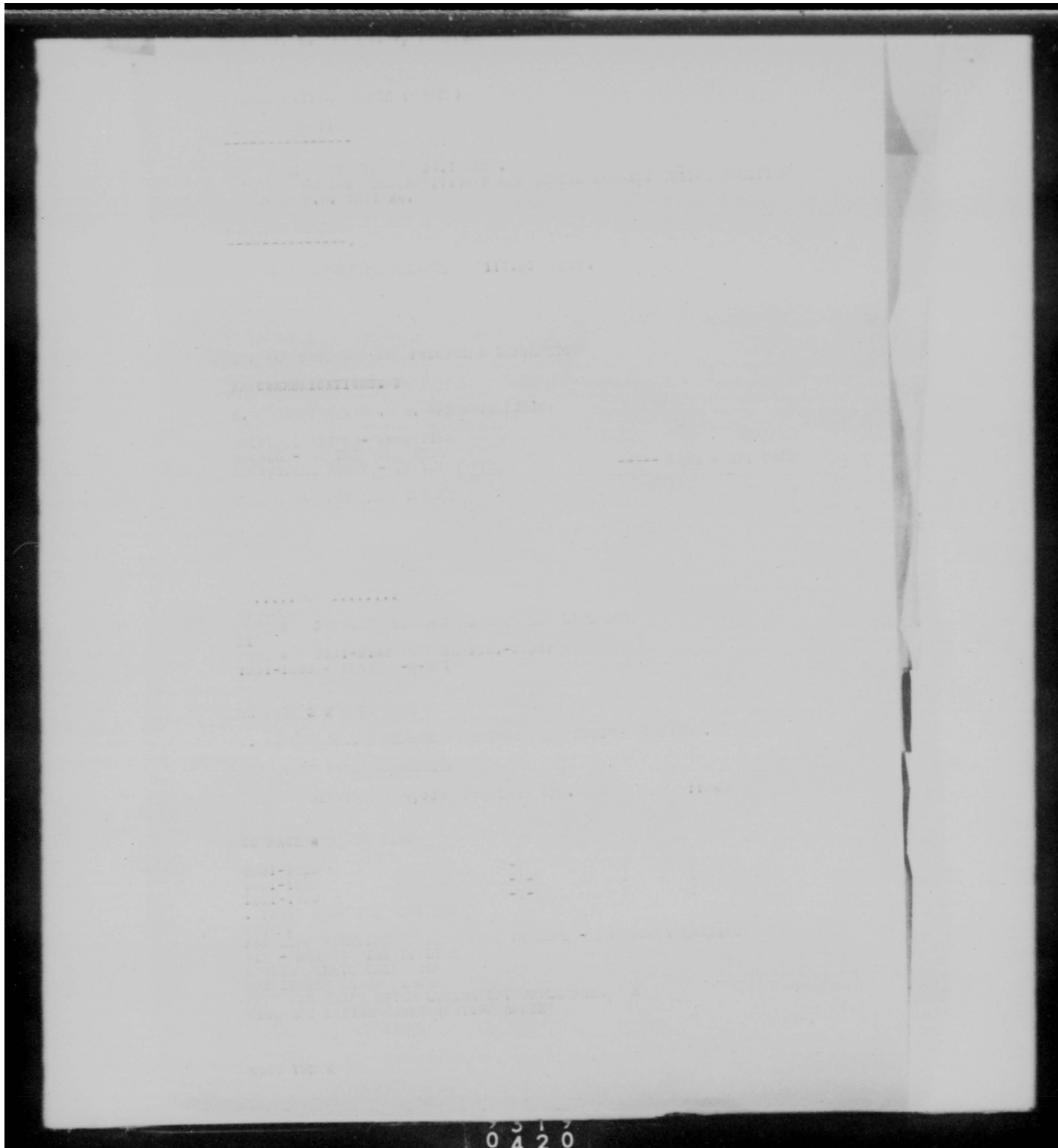

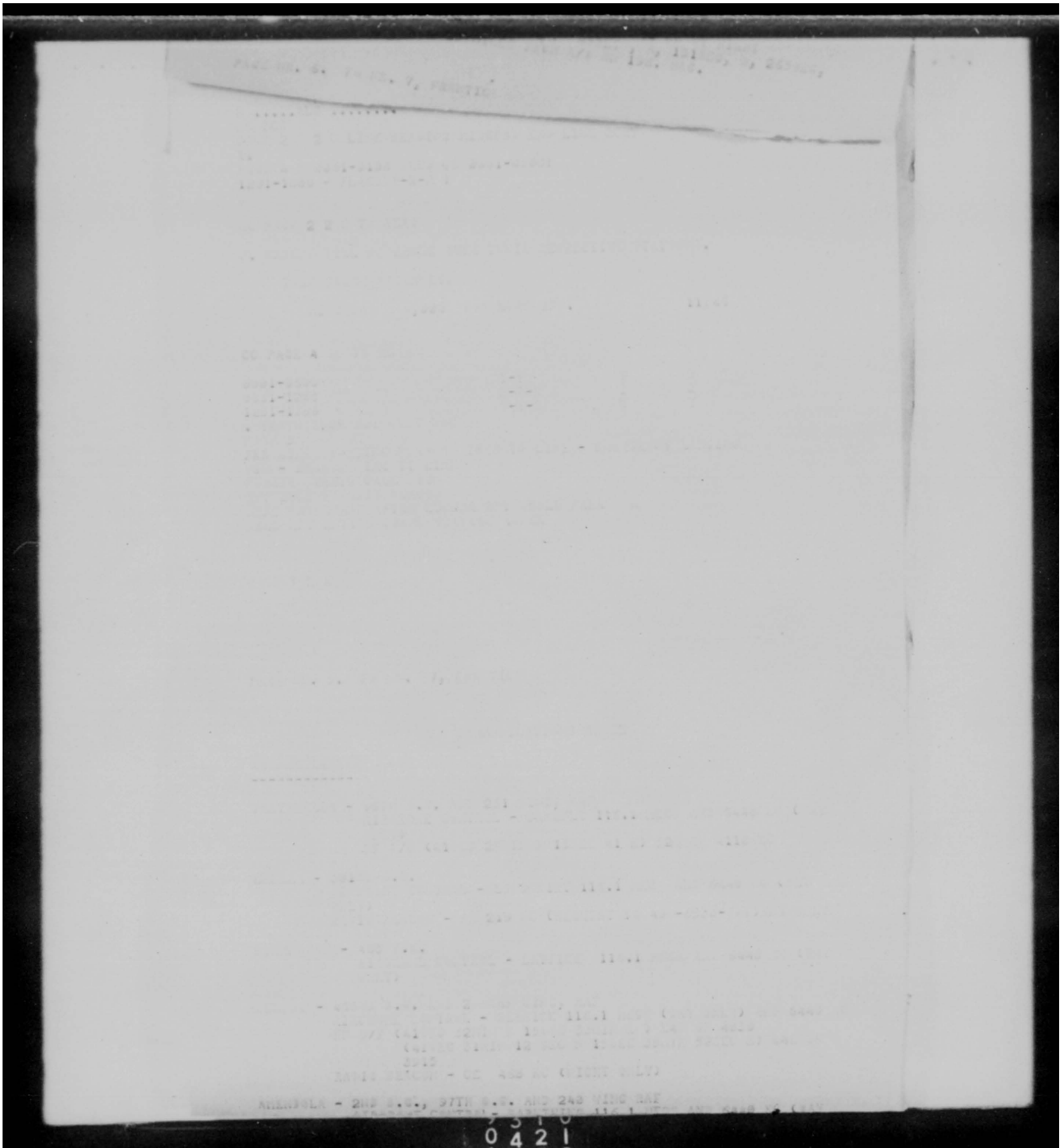

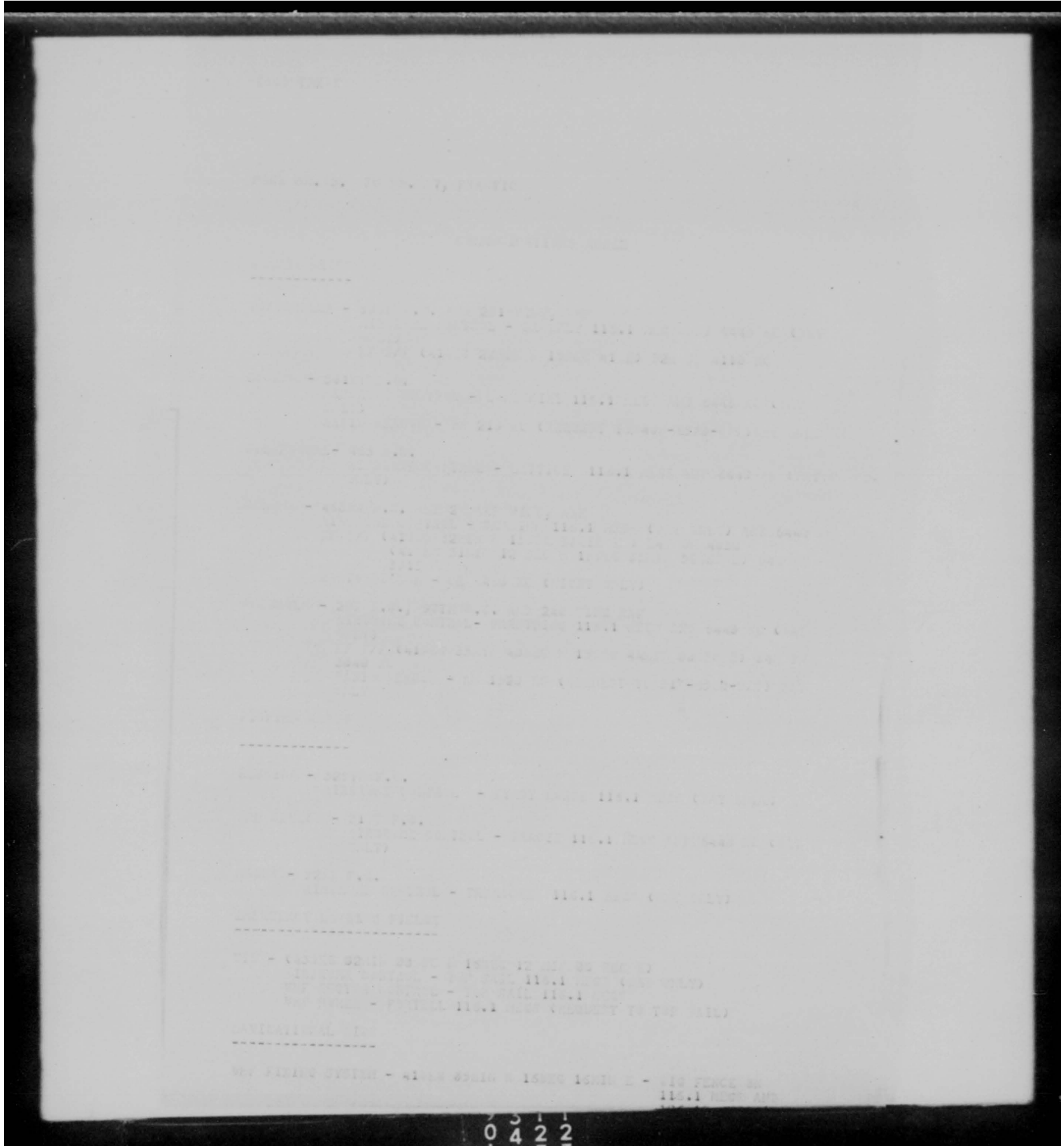

0 4 2 2

-----  
AIRMAIL - 110.1  
AIRMAIL - 110.1

AIRMAIL - 110.1  
AIRMAIL - 110.1

AIRMAIL - 110.1  
AIRMAIL - 110.1

-----  
AIRMAIL - 110.1

AIRMAIL - 110.1  
AIRMAIL - 110.1  
AIRMAIL - 110.1

-----  
AIRMAIL - 110.1

AIRMAIL - 110.1  
AIRMAIL - 110.1  
AIRMAIL - 110.1

-----  
AIRMAIL - 110.1

AIRMAIL - 110.1  
AIRMAIL - 110.1  
AIRMAIL - 110.1

-----  
AIRMAIL - 110.1

-----  
AIRMAIL - 110.1

-----  
AIRMAIL - 110.1

AIRMAIL - 110.1  
AIRMAIL - 110.1

-----  
AIRMAIL - 110.1

AIRMAIL - 110.1

-----  
AIRMAIL - 110.1

AIRMAIL - 110.1  
AIRMAIL - 110.1  
AIRMAIL - 110.1

-----  
AIRMAIL - 110.1

-----  
AIRMAIL - 110.1

-----  
AIRMAIL - 110.1

0 4 2 3

SECRET

Task Force CO

HEADQUARTERS  
EASTERN COMMAND  
U S STRATEGIC AIR FORCES IN EUROPE

19 SEPTEMBER 1944.

FIELD ORDER )

FRANTIC 7 )

1. A. SEE INTELLIGENCE ANNEX.

B. FRIENDLY ACTIVITIES.

(1) FIGHTER SUPPORT.

8TH AIR FORCE TASK FORCE FIGHTERS WILL RENDEZVOUS  
WITH THIS FORCE AT 48°41' N - 25°30' E AND WILL  
ESCORT THE BOMBERS THROUGH THE TARGET AREA AND  
TO THE LIMIT OF THEIR ENDURANCE.

2. A. TARGETS:

(1) PRIMARY

~~SZOLNOK M/Y & ZAGYVA RRBR, HUNGARY~~  
TARGET CHART NO. 12-25-NA

13 A WING

MPI - RAILROAD ENGINEERING SHOPS 10-J  
LEAD GP - WESTERN SHOPS  
HIGH GP - CENTRAL SHOPS  
LOW GP - EASTERN SHOPS  
(SEE TARGET FOLDERS ATTACHED)

13 B WING

MPI - M/Y 12-N  
LEAD GP - SOUTHWESTERN CHOKE POINT OF M/Y  
HIGH GP - SOUTHWESTERN SECTION OF MARSHALLING  
YARDS.  
LOW GP - CENTRAL SECTION OF M/Y  
(SEE TARGET FOLDERS ATTACHED)

13 C WING

MPI - M/Y 12-0  
LEAD GP - CENTRAL SECTION OF M/Y  
HIGH GP - NORTHWESTERN SECTION OF M/Y  
LOW GP - NORTHWESTERN CHOKE POINT OF M/Y  
(SEE TARGET FOLDERS ATTACHED)

(2) SECONDARY:

~~SZOMBATHELY RR JCTS & M/Y, HUNGARY~~  
TARGET CHART NO. 1201C-NA

SECRET

- 1 -

0 4 2 4

PAGE # 2. FO # 7, FRANTIC . S E C R E T

## 2. A. (2) CONTD.

13 A WING  
 MPI-M/Y SOUTH OF RR SHOPS . (M-13)  
 13 B WING  
 VIADUCT OVER M/Y . (N-11)  
 13 C WING  
 RAILROAD REPAIR SHOPS . (M-14)

## B. FORCE REQUIRED:

13 A WING - MAX EFFORT - 95TH GP  
 13 B WING - MAX EFFORT - 100TH GP  
 13 C WING - MAX EFFORT - 390TH GP

## C. GROUPS WILL ASSEMBLE OVER THEIR RESPECTIVE STATIONS.

## TASK FORCE ASSEMBLY:

MIRGOROD 4,000 FOR LEAD GPS. 11:46

## D. ROUTES:

|                                 |        |       |
|---------------------------------|--------|-------|
| MIRGORAD (CP #1)                | 4,000  | 11:46 |
| 4841 N - 2530 E (CP # 2)        |        | 13:40 |
| 4741 N - 2131 E                 | 20,000 | 14:28 |
| 4713 N - 2045 E (IP)            |        | 14:41 |
| TGT                             | 20,000 | 14:49 |
| 4657 N - 2009 E (RP)            |        | 14:54 |
| 4313 N - 1633 E (START DESCENT) |        | 16:17 |
| BASES                           |        | 16:54 |

TIMINGS FOR 13 A WING ~~XXX~~  
 13 B ADD 2 MIN, 13 C ADD 4 MIN.

## E. BOMBING ALTITUDES:

LEAD GPS 20,000 FT.

- X. (1) ZERO HOUR: 11:46 (LOCAL TIME)  
 (2) REFERENCE BASE ALTITUDE - 20,000  
 (3) MAYPOLE 3 - TARGET WEATHER REPORT 20 MINS BEFORE  
 TARGET TIME.  
 (4) BOMB LOAD: 8 X 500 #GP(RUSSIAN)  
 (5) LEADERS - NO CHANGE  
 (6) FLARES - NO CHANGE  
 (7) R/T CALLSIGNS - NO CHANGE  
 (8) ALL A/C CHANGE TO CHANNEL "A" AFTER TAKING OFF  
 FROM BASES.  
 (9) ITALIAN BASES:

13 A WING WILL BAND AT LUCERA AND TORTORELLA

S E C R E T

- 2 -

0 4 2 5



SECRET

PAGE # 3. FO # 7, FRANTIC

*STENPARONE*

2. X. (9) 13 B WING WILL LAND AT STERA AND CELONE

13 C WING WILL LAND AT AMENDOLA

MAYPOLE 3 AND PHOTO RECON AIRCRAFT WILL LAND  
AT LUCERA.

FIGHTERS:

2 SQUADRONS WILL LAND AT SAN SEVERO  
1 SQUADRON WILL LAND AT LESINA  
1 SQUADRON WILL LAND AT MADNA

3. OMIT.

4. NORMAL.

SECRET

-3-

0 4 2 6

## 5. COMMUNICATIONS.

A. RUSSIAN BEACONS IN OPERATION - NONE

## B. RECOGNITION:

| <u>ALLIED</u><br>GMT | FLARE              | CHALLENGE | ANSWER |
|----------------------|--------------------|-----------|--------|
| 0001-0600            | Y-Y <del>W-W</del> | Y         | B      |
| 0601-1200            | R-R-R              | I         | Q      |
| 1201-1800            | Y-Y-R              | W         | Y      |
| 1801-2400            | Y-Y                | X         | S      |

RUSSIAN

CHALLENGE - DIP LEFT WING 2 TO 3 TIMES AND FIRE GREEN FLARE  
ANSWER - DIP RIGHT WING 3 TO 5 TIMES

## C. VHF CALL SIGNS:

BOMBER S: ~~VINE GROVE 61, 62, 63~~ *13A WING - VINE GROVE ONE ONE*  
*13B " - VINE GROVE ONE TWO*  
*13C " - VINE GROVE ONE THREE*  
FIGHTERS: BALANCE 1

## D. VHF CODE WORDS:

AUTHENTICATION - CHOPSTICK  
RECALL - DO THE ONCE OVER  
INDIVIDUAL ABORT - KENTUCKY HOME

E. D/F VERIFICATION: SD 0220 CARD 362

## F. BOMBER STRIKE MESSAGE:

SEND TO XBR ON 5495 AND 1TL ON 6710 AND 12380 KC. USE NORMAL STRIKE MESSAGE PROCEEDURE EXCEPT NAME OF TARGET WILL BE SENT.

G. CONTROL POINT MESSAGE: NONE

H. BUNCHER BEACONS: POLTAVA - C/S WX FREQ 1510 KC  
MIRGOROD - C/S DC FREQ 1710 KC  
IN OPERATION FROM 0300Z TO 1800Z.

I. IFF INFORMATION

IFF WILL BE TURNED ON AT TAKE OFF: OFF WHEN CROSSING THE FRONT LINES AND TURNED BACK ON WHEN CROSSING THE YUGOSLAV COAST AND TURNED OFF UPON LANDING,

J. MESSAGE TO ITALIAN STATIONS WILL BE SENT IN CLEAR ONLY IN EMERGENCY.

K. CARPET: NONE

L. WINDOW: 360 UNITS TO BE RELEASED 3 MINUTES BEFORE TARGET TO ~~REMAIN~~ CONTINUE FOR 15 MINUTES.

## COMMUNICATIONS ANNEX

BOMBER BASES

TORTORELLA - 99TH B.G. AND 231 WING, RAF  
 AIRDROME CONTROL - SANDFLY 116.1 MEGS AND 6440 KC (DAY ONLY)  
 HF D/F (41° 28' N 15° 41' E) 52Q ON 4110 KC

LUCERA - 301ST B.G.  
 AIRDROME CONTROL - LONGSKIRT 116.1 MEGS AND 6440 KC (DAY ONLY)  
 RADIO BEACON - RA 219 KC (REQUEST TO 40N-6530-W/T) DAY ONLY

STERPARONE - 483 B.G.  
 AIRDROME CONTROL - LATTICE 116.1 MEGS AND 6440 KC (DAY ONLY)

CELONE - 463RD B.G AND 2 SAAF WING, RAF  
 AIRDROME CONTROL - SEASICK 116.1 MEGS (DAY ONLY) AND 6440 KC  
 HF D/F (41° 32' N 15° 33' E) L4B ON 4030  
 (41° 31' 12" N 15° 35' 52" E) 84L ON 3915  
 RADIO BEACON - CE 460 KC (NIGHT ONLY)

AMENDOLA - 2ND B.G., 97TH B.G. AND 240 WING RAF  
 AIRDROME CONTROL - DARNTHING 116.1 MEGS AND 6440 KC (DAY ONLY)  
 HF D/F (41° 33' 40" N 15° 44' 00" E) 84M ON 3040 KC  
 RADIO BEACON - AM 1520 KC (REQUEST TO 31K-6530-W/T) DAY ONLY

FIGHTER BASES

LESSINA - 325TH F.G  
 AIRDROME CONTROL - FIRST HORSE 116.1 MEGS (DAY ONLY)

SAN SEVERO - 31ST F.G  
 AIRDROME CONTROL - GRACIE 116.1 MEGS AND 6440 KC (DAY ONLY)

MADNA - 52ND F.G  
 AIRDROME CONTROL - TREADCAR 116.1 MEGS (DAY ONLY)

EMERGENCY LANDING FIELDS

VIS - (43° 02' 00" N 16° 12' 00" E)  
 AIRDROME CONTROL - TOP SAIL 116.1 MEGS (DAY ONLY)  
 VHF SECTOR CONTROL - TOP SAIL 116.1 MEGS  
 VHF HOMER - FORTTELL 116.1 MEGS (REQUEST TO TOP SAIL)

NAVIGATIONAL AIDS

VHF FIXING SYSTEM - 41° 05' N 16° 16' E - BIG FENCE ON 116.1 MEGS AND  
 126.18 MEGS (DAY ONLY)

RADIO RANGE - WITH Z MARKER BEACON

FOGGIA - (41° 31' 10" N 15° 33' 10" E)  
 CALL SIGN - FO ON FREQUENCY 263 KC.  
 CONTINUOUS BY DAY - REQUEST 84L ON 3560 KC BY NIGHT  
 MAGNETIC COURSES TO STATION: 85°, A, 151°, N, 265°, A, 331°, N  
 6.25 MILES FROM A/D ON 198 MAG.

HEADQUARTERS EASTERN COMMAND, U.S. STRATEGIC AIR FORCES IN EUROPE  
 H I B 2 1 1 0 Z E B R A \* E

|                |              |
|----------------|--------------|
| PRECEDENCE     | OPS PRIORITY |
| CLASSIFICATION | SECRET       |
| DATE           | 18 SEPT 44   |
| SERIAL NR      |              |

|                        |
|------------------------|
| DEPT. ORG.             |
| INITIALS               |
| ORIGINATOR             |
| IS DEPT. COND. FOR OPS |
| INITIALS               |
| FILE COND.             |

TO: \_\_\_\_\_

TARGET DEBRECEN INTENDED AS PRIMARY FOR FRANTIC SEVEN CMA ONE NINE  
 SEPTEMBER CMA NOT APPROVED BY RUSSIANS PD SPAATZ AND EAKER INFO WALSH  
 FROM KESSLER SIGNED WALSH TARE EIGHT NINE ZERO PD  
 THEY INFORM US THAT RED AIR FORCE INTENDS TO ATTACK THIS TARGET SAME DATE PD  
 TASK FORCE WILL NOW ATTACK SZOLNOK AS PRIMARY AT ONE TWO TWO TWO ZEBRA PD  
 THIS CORRECTS OUT TARE EIGHT NINE ZERO OKAY

7-873



REFERENCES:  
 THE MAKING OF AN EXACT COPY OF THIS MESSAGE IS FORBIDDEN. ONLY SUCH  
 EXTRACTS AS ARE ABSOLUTELY NECESSARY WILL BE MADE AND PROPERLY  
 CLASSIFIED

0429

~~SECRET~~

HEADQUARTERS  
EASTERN COMMAND  
U S STRATEGIC AIR FORCES IN EUROPE

18 Sept 44.

My Dear General Perminov.

The target for the Frantic Force going to Italy  
19 September has been changed. The force will attack  
SZOLNOK ( 47°10' N 20°10' E ). Approximate time over target  
1500 hours Moscow time. Time over front line and routes  
the same as in Plan B.

Sincerely,

T. A. HANSON,  
Lt. Col., A.C.  
Deputy Comdr for Ops.

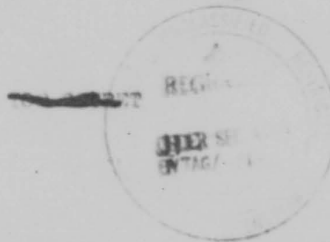

0 4 3 0

*ops Priority*  
~~SECRET~~

00

SECRET

Sept 18, 1944

*T892*

BATTLE DAMAGE SLIGHT PR EXPECT TO HAVE EIGHT FOUR  
BAKER ONE SEVENS AND SIX ONE PETER FIVE ONES TAKE  
OFF TOMORROW MORNING AT ONE ZERO ZERO ZERO FOR  
ITALY PAREN TO DEPART FOR WALSH FROM KESLER SIGNED  
WALSH PARE PAREN REMAINING  
PLANES WILL ~~BE~~ IN FROM ONE TO FIVE DAYS

*BE operational*



0 4 3 1



HEADQUARTERS EASTERN COMMAND, U.S. STRATEGIC AIR FORCES IN EUROPE  
 OUTGOING MESSAGE

|                |                   |                      |
|----------------|-------------------|----------------------|
| PRECEDENCE     | URGENT            | DEP. CMDR'S INITIALS |
| CLASSIFICATION | SECRET            | ORIGINATOR           |
| DATE           | 18 SEPTEMBER 1944 | DUTY OPS INITIALS    |
| SERIAL NR      |                   | TIME CLRD.           |

TO:

TASK FORCE COMMANDER FRANTIC SEVEN INTENDS TO ATTACK TARGET PRIMARY CMA  
 SECONDARY ON WAY TO ITALY ONE NINE SEPTEMBER PD SPAATZ AND EAKER FROM  
 WALSH TARE EIGHT NINE ZERO PAREN TIME AT TARGET ONE TWO  
 ZERO ZERO ZEBRA PD ARRIVAL ITALIAN BASES ONE FOUR THREE ZERO ZEBRA PD WILL  
 ATTACK PRIMARY TARGET BAKER HOW DASH NINE ONE AIRFIELD RAIL ROAD ENGINEERING  
 WORKS AND MARSHALLING YARDS SECONDARY TARGET SZ BAKER HOW DASH FOUR TWO  
 ABLE AND BAKER FINISHED



REFERENCES:

THE MAKING OF AN EXACT COPY OF THIS MESSAGE IS FORBIDDEN. ONLY SUCH  
 EXTRACTS AS ARE ABSOLUTELY NECESSARY WILL BE MADE AND PROPERLY  
 CLASSIFIED

0 4 3 2

HEADQUARTERS EASTERN COMMAND, U.S. STRATEGIC AIR FORCES IN EUROPE  
**ROUTING MESSAGE**

|                |                          |
|----------------|--------------------------|
| PRECEDENCE     | <b>URGENT</b>            |
| CLASSIFICATION | <b>SECRET</b>            |
| DATE           | <b>18 SEPTEMBER 1944</b> |
| SERIAL NR      |                          |

|                                 |
|---------------------------------|
| DEP. CMDR'S<br>INITIALS         |
| ORIGINATOR<br><b>OPERATIONS</b> |
| DUTY OFFICER<br>INITIALS        |
| TIME CLSD.                      |

TO: \_\_\_\_\_

AT ~~08~~ ONE TWO THREE FIVE ZEBRA MOSQUITO ARRIVED BEFORE THE MISSION PD  
 SPAATZ FOR DOLLITTLE FROM KESSLER SIGNED WALSH TARE EIGHT EIGHT  
NINE PD NEW SUBJECT IN REFERENCE TO OTHER MOSQUITO MESSAGE  
 WAS SENT ~~ON~~ SIXTEENTH ~~SEPTEMBER~~ IN TARE EIGHT ONE TWO PD BOTH PLANES  
 POLTAVA SAFE

*T-889*



REFERENCES:

THE MAKING OF AN EXACT COPY OF THIS MESSAGE IS FORBIDDEN. ONLY SUCH  
 EXTRACTS AS ARE ABSOLUTELY NECESSARY WILL BE MADE AND PROPERLY  
 CLASSIFIED

0 4 3 3

HEADQUARTERS EASTERN COMMAND, U.S. STRATEGIC AIR FORCES IN EUROPE

ROUTING MESSAGE

|                |                   |  |
|----------------|-------------------|--|
| PRECEDENCE     | OR PRIORITY       | DEP. CMDR'S<br>INITIALS                  |
| CLASSIFICATION | SECRET            | ORIGINATOR                               |
| DATE           | 18 SEPTEMBER 1944 | OPERATIONS<br>DUTY OFFICER'S<br>INITIALS |
| SERIAL NR      |                   | TIME GRD.                                |

TO:

TOTAL AIRCRAFT AT EASTERN COMMAND BASES PAREN DEANE FROM WALSH TARE  
~~CIGHT FIGHT BATT~~ PAREN ONE ZERO FIVE BAKER ONE SEVENS AND SIX  
 TWO PETER FIVE ONES PD BATTLE DAMAGE TO FOLLOW

105 B17s

46-Mia

59-Polt.

62-P-51s



REFERENCES:

THE MAKING OF AN EXACT COPY OF THIS MESSAGE IS FORBIDDEN. ONLY SUCH  
 EXTRACTS AS ARE ABSOLUTELY NECESSARY WILL BE MADE AND PROPERLY

0434

HEADQUARTERS EASTERN COMMAND, U.S. STRATEGIC AIR FORCES IN EUROPE  
 2 U I G G I N G M E S S A G E

|                |                   |                         |
|----------------|-------------------|-------------------------|
| PRECEDENCE     | URGENT            | DEP. CMDR'S<br>INITIALS |
| CLASSIFICATION | SECRET            | ORIGINATOR              |
| DATE           | 18 SEPTEMBER 1944 | OPERATIONS              |
| SERIAL NR      |                   | DUTY O'S<br>INITIALS    |
|                |                   | TIME CLRD.              |

TO: \_\_\_\_\_

TOTAL AIRCRAFT AT EASTERN COMMAND BASES PAREN SPAATX AND DOOLITTLE  
 FROM WALSH TARE \_\_\_\_\_ PAREN ONE ZERO FIVE  
 BAKER ONE SEVENS AND SIX TWO PETER FIVE ONES SAFE



REFERENCES:

THE MAKING OF AN EXACT COPY OF THIS MESSAGE IS FORBIDDEN. ONLY SUCH  
 EXTRACTS AS ARE ABSOLUTELY NECESSARY WILL BE MADE AND PROPERLY

0 4 3 5

~~SECRET~~  
HEADQUARTERS  
EASTERN COMMAND  
U S STRATEGIC AIR FORCES IN EUROPE

18 Sept 44.

My Dear General Persinov.

One F-5 will be dispatched from Poltava and  
follow the Bombers by one hour.

Sincerely,

WILLIAM A. SULLIVAN JR  
Lt Colonel, Air Corps,  
Deputy Comdr for Ops.



0 4 3 6

~~SECRET~~

HEADQUARTERS  
EASTERN COMMAND  
U S STRATEGIC AIR FORCES IN EUROPE

18 Sept 44.

My Dear General Perminov.

Plan B, in our letter 14 September, has been chosen for the Prantic 7 flight to Italy 19 September 1944.

PLAN B

|                    |                         |            |
|--------------------|-------------------------|------------|
| Take off Solbava   | 1130 hours Moscow time. |            |
| Gate out 48°33' N  | 1506 hours Moscow time. | 20,000 ft. |
| ECLEPINA 25°03' E  |                         |            |
| Target 47°32' N    | 1607 hours Moscow time. | 20,000 ft. |
| DEBRECZEN 21°38' E |                         |            |
| Italian Bases      | 1830 hours Moscow time. |            |

Two (2) Mosquitos will precede this mission to Italy by thirty (30) minutes.

Sincerely,

WILLIAM A. SULLIVAN, Jr.  
Lt. Colonel, Air Corps.  
Deputy Comdr for Ops.



0437



~~SECRET~~

HEADQUARTERS  
EASTERN COMMAND  
U S STRATEGIC AIR FORCES IN EUROPE

18 Sept 1944.

My Dear General Pershinov.

It is anticipated that the Frantic Seven mission to Italy will depart Russian bases 19 September 1944, following one of the plans submitted to you in our letter of the 14 September 1944. As soon as one of the plans is chosen you will be notified.

Sincerely,

THOMAS K. HAMPTON,  
Lt Colonel, Air Corps,  
Deputy CG for Operations.



~~SECRET~~  
0438

HEADQUARTERS EASTERN COMMAND, U.S. STRATEGIC AIR FORCES IN EUROPE  
 Q U I R R I N G M E S S A G E

|                |              |
|----------------|--------------|
| PRECEDENCE     | OPS PRIORITY |
| CLASSIFICATION | SECRET       |
| DATE           | 17 SEPT 44   |
| SERIAL NR      | T 847        |

|                                     |
|-------------------------------------|
| DEP. DIR'S<br>INITIALS              |
| ORIGINATOR<br>IDENTITY CODE FOR OPS |
| DUTY OFFICER'S<br>INITIALS          |
| TIME CLRD.                          |

TO: \_\_\_\_\_

AS SCHEDULED ON FOUR SEPTEMBER PREVIOUSLY GIVEN SPACE FOR  
 DOUBLE THE AIR BALON TAG 847 WHICH ON ONE EIGHT  
 SEPTEMBER PLACED WILL BE IN OPERATION



REFERENCES:

THE MAKING OF AN EXACT COPY OF THIS MESSAGE IS FORBIDDEN. ONLY SUCH  
 EXTRACTS AS ARE ABSOLUTELY NECESSARY WILL BE MADE AND PROPERLY  
 CLASSIFIED

0439

HEADQUARTERS  
EASTERN COMMAND  
U S STRATEGIC AIR FORCES IN EUROPE

17 SEPT 44.

BY DEAR COLONEL TORSMAN:

IT IS REQUESTED THAT BLAGONS NUMBER 3, NUMBER 4,  
NUMBER 5, NUMBER 7, AND NUMBER 10 BE PLACED IN OPERATION  
FROM 1400 HOURS TO 1600 HOURS WORTH TILL BY 17 SEPTEMBER 44.  
Sincerely,

BILLY F. WILSON,  
CAPTAIN, AIR CORPS,  
OPERATIONS OFFICER



0 4 4 0

HEADQUARTERS  
EASTERN COMMAND  
U. S. STRATEGIC AIR FORCES IN EUROPE

17 SEPTEMBER 1944

MY DEAR GENERAL PERMINDY:

DUE TO ADVERSE WEATHER CONDITIONS CRANTIC SEVEN HAS BEEN  
CANCELLED FOR 17 SEPTEMBER 1944.

GENERAL SPATT INFORMS US THAT CRANTIC SEVEN WILL TAKE PLACE  
SEPTEMBER 18, 1944 USING THE SAME FLIGHT PLAN, WEATHER PERMITTING.

SINCERELY,

T. K. HAMPTON,  
LT COLONEL, A D CORPS,  
DEPUTY CO FOR OPERATIONS.

0 4 4 1

HEADQUARTERS EASTERN COMMAND, U.S. STRATEGIC AIR FORCES IN EUROPE  
 C I G O I N O M E S S A G E

|                |                   |                      |
|----------------|-------------------|----------------------|
| PRECEDENCE     | URGENT            | DEP. CMDR'S INITIALS |
| CLASSIFICATION | <del>SECRET</del> | ORIGINATOR           |
| DATE           | 10 SEPT 44        | DEPUTY CHIEF FOR OPS |
| SERIAL NR      | 7833              | DIRY O'S INITIALS    |
|                |                   | TIME CRD.            |

TO:

FRANTIC SEVEN PAREN TO SPAATZ AND DOOBITTLE FROM WALSH TARE 833  
 TOPREC PAREN FOR SEPTEMBER SEVENTEENTH CLEARED REPEAT CLEARED BY  
 SOVIETS ALRIGHT



REFERENCES:

THE MAKING OF AN EXACT COPY OF THIS MESSAGE IS FORBIDDEN. ONLY SUCH  
 EXTRACTS AS ARE ABSOLUTELY NECESSARY WILL BE MADE AND PROPERLY  
 CLASSIFIED

0442

HEADQUARTERS EASTERN COMMAND, U.S. STRATEGIC AIR FORCES IN EUROPE  
 P R I O R I T Y M E S S A G E

|                |            |                                 |
|----------------|------------|---------------------------------|
| PRECEDENCE     | URGENT     | DEP. CMDR'S<br>INITIALS         |
| CLASSIFICATION | SECRET     | ORIGINATOR                      |
| DATE           | 10 SEPT 44 | DEPUTY CMDR FOR OPS<br>INITIALS |
| SERIAL NR      | T 822      | TIME GRD.                       |

TO: \_\_\_\_\_

FLIGHT PLAN FOR TRANTIC SEVEN FOR ONE SEVEN SEPTEMBER ESTIMATES  
 ARRIVAL POLTAVA ONE FIVE MINUTES AFTER SUNDOWN PD TO SPAATZ FOR  
 DOOLITTLE FROM WALSH TARE \_\_\_\_\_ PD ONE HALF OF FORCE  
 WILL LAND IN DARKNESS PD ONLY INADEQUATE NIGHT LIGHTING AVAILABLE  
 PD RECOMMEND MOVING SCHEDULE THREE ZERO MINUTES AHEAD PD RUSSIAUS  
 HAVE BEEN NOTIFIED



REFERENCES: \_\_\_\_\_

THE MAKING OF AN EXACT COPY OF THIS MESSAGE IS FORBIDDEN. ONLY SUCH  
 EXTRACTS AS ARE ABSOLUTELY NECESSARY WILL BE MADE AND PROPERLY  
 CLASSIFIED

0443



HEADQUARTERS EASTERN COMMAND, U.S. STRATEGIC AIR FORCES IN EUROPE  
 AIRBORNE MESSAGE

|                |                   |                        |
|----------------|-------------------|------------------------|
| PRECEDENCE     | OPS PRIORITY      | DEP. CHIEF'S INITIALS  |
| CLASSIFICATION | <del>SECRET</del> | ORIGINATOR             |
| DATE           | 16 SEPT 44        | REP. TY. CORR. FOR OPS |
| SERIAL NR      | T 821             | INITIALS               |
|                |                   | TIME CLRD.             |

TO:

BEACONS WILL BE IN OPERATION ONE SEVEN SEPTEMBER PAREN SPAATZ FOR  
 DOGLITTLE FROM WALSH TARE 821 PAREN AS SCHEDULED  
 ONE FOUR SEPTEMBER PREVIOUSLY



REFERENCES:

THE MAKING OF AN EXACT COPY OF THIS MESSAGE IS FORBIDDEN. ONLY SUCH  
 EXTRACTS AS ARE ABSOLUTELY NECESSARY WILL BE MADE AND PROPERLY

0444

██████████  
HEADQUARTERS  
EASTERN COMMAND  
U S STRATEGIC AIR FORCES IN EUROPE

16 September 1944.

My Dear General Kermilov.

Strategic 7 is now scheduled for 17 September 1944.  
The force will consist approximately of 100 bombers and 70  
fighters. The targets and routes will be the same with the  
following variations in the times.

Bombers over target 1900 hours Moscow time. 14,000 ft.

Bombers land Pirograd 1850 hours Moscow time.

Bombers land Poltava 1910 hours Moscow time.

Fighters land Peryatin 1805 hours Moscow time.

One Mosquito will precede the flight by 20 minutes  
landing at Poltava.

Sincerely,

E.K. HAMPTON,  
Lt. Col. AC.  
Deputy Comdr for Ops.



0 4 4 5

HEADQUARTERS  
EIGHTH AIR FORCE  
U S STRATEGIC AIR FORCES IN EUROPE

16 September 1944.

My Dear Colonel Forgan:

It is requested that Beacons Number 3, Number 4,  
Number 6, Number 7, and Number 10 be placed in operation  
from 1400 Hours to 2100 Hours Moscow time on 17 September 44.

Sincerely,

RALPH W. WILSON,  
Captain, Air Corps,  
Operations Officer.



0446

URGENT

SECRET

OPERATIONS

16 SEPTEMBER 1944

ANNOUNCING THE ARRIVAL OF MOSQUITO LAMPOL THREE PAREN SPAATZ FOR DOOLITTLE  
SIGNED WALSH YARD SECRET ONE TWO PAREN AT ONE THREE  
FIVE THREE ZERO ONE FIVE SEPTEMBER SAFE

T-812



0447



HEADQUARTERS EASTERN COMMAND, U.S. STRATEGIC AIR FORCES IN EUROPE  
 OUTGOING MESSAGE

|                    |                      |
|--------------------|----------------------|
| PRECEDENCE         | DEP. CMDR'S INITIALS |
| CLASSIFICATION     | ORIGINATOR           |
| DATE<br>18 Sept 44 | DUTY O'S INITIALS    |
| SERIAL NR<br>T 787 | TIME CLRD.           |
| TO:                |                      |

OPERATIONAL MESSAGE UNIT BUT UNIT SIGNATURE



REFERENCES:

THE MAKING OF AN EXACT COPY OF THIS MESSAGE IS FORBIDDEN. ONLY SUCH EXTRACTS AS ARE ABSOLUTELY NECESSARY WILL BE MADE AND PROPERLY CLASSIFIED

0449



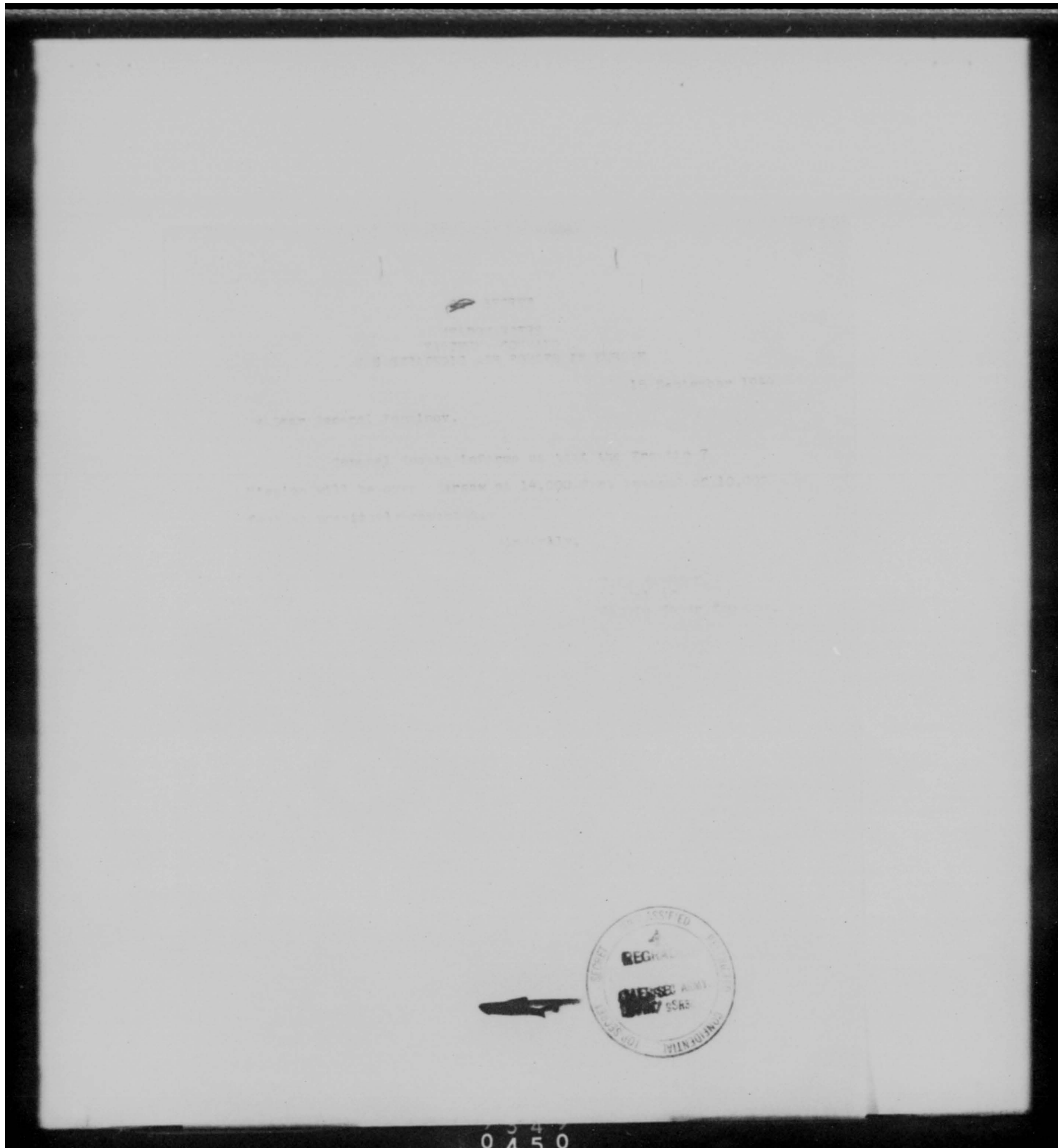

SECRET

HEADQUARTERS  
EASTERN COMMAND  
USSTAF

14 SEPTEMBER 1944.

MY DEAR COLONEL TORGMAN:

IT IS REQUESTED THAT BEACONS NUMBER 3, NUMBER 4, NUMBER 6,  
NUMBER 7, AND NUMBER 10 BE PLACED IN OPERATION FROM 14:00 HOURS  
TO 21:00 HOURS MOSCOW TIME ON 15 SEPTEMBER 1944.

SINCERELY,

WILLIAM A. SULLIVAN JR.  
LT COLONEL, AIR CORPS,  
DEPUTY CD FOR OPERATIONS.



SECRET

0451

HEADQUARTERS EASTERN COMMAND, U.S. STRATEGIC AIR FORCES IN EUROPE  
 O U T G O I N G M E S S A G E

|                |                   |                       |
|----------------|-------------------|-----------------------|
| PRECEDENCE     | OPS PRIORITY      | DEP. CMDR'S INITIALS  |
| CLASSIFICATION | SECRET            | ORIGINATOR OPERATIONS |
| DATE           | 14 SEPTEMBER 1944 | DUTY O'S INITIALS     |
| SERIAL NR      | T                 | TIME CLRD.            |

TO: JRPD

BEACONS WILL BE IN OPERATION ONE FIVE SEPTEMBER PAREN SPAATZ FOR  
 DOOLITTLE FROM WALSH TARE \_\_\_\_\_ PAREN AS SCHEDULED  
 ONE FOUR SEPTEMBER PREVIOUSLY



REFERENCES:

THE MAKING OF AN EXACT COPY OF THIS MESSAGE IS FORBIDDEN. ONLY SUCH  
 EXTRACTS AS ARE ABSOLUTELY NECESSARY WILL BE MADE AND PROPERLY  
 CLASSIFIED

7768  
 0452

HEADQUARTERS EASTERN COMMAND, U.S. STRATEGIC AIR FORCES IN EUROPE  
 OUTGOING MESSAGE

|                           |                          |
|---------------------------|--------------------------|
| PRECEDENCE<br>URGENT      | DEP. CMDR'S<br>INITIALS  |
| CLASSIFICATION            | ORIGINATOR<br>OPERATIONS |
| DATE<br>14 SEPTEMBER 1954 | DUTY O'S<br>INITIALS     |
| SERIAL NR<br>T            | TIME CLRD.               |

TO: JSPD

FLIGHT PLAN FOR TRANSIC SEVEN PAREN SPATE FOR DOOLITTLE FROM WALSH  
 TOPSEC TARE \_\_\_\_\_ PAREN AS SUBMITTED FOR ONE FIVE  
 SEPTEMBER HAS SOVIET APPROVAL

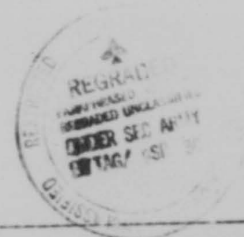

REFERENCES:

THE MAKING OF AN EXACT COPY OF THIS MESSAGE IS FORBIDDEN. ONLY SUCH  
 EXTRACTS AS ARE ABSOLUTELY NECESSARY WILL BE MADE AND PROPERLY  
 CLASSIFIED

0453

~~SECRET~~

SEPT 14 1944

ASSIGNED TO SEPT ONE FIVE WAS PRATICED UNDER POWER TO DEANE  
FROM WALKY TOPS C TURE  
HAVE REQUESTED SOVIET APPROVAL SAID PLAN



0 4 5 4

~~SECRET~~  
HEADQUARTERS  
EASTERN COMMAND  
U S STRATEGIC AIR FORCES IN EUROPE

14 September 1944.

My Dear General Perminov.

We have just been informed by General Spatz that the Mission expected in here to-day , 14 September , will not come in. General Spatz requests that the same Flight Plan be cleared for to-morrow, 15 September.

Sincerely ,

WILLIAM A. SULLIVAN, Jr.  
Lt. Colonel, A.C.,  
Deputy Commander for Ops.



0 4 5 5



~~TOP SECRET~~  
 U.S. AIR FORCE  
 EASTERN COMMAND  
 US STRATEGIC AIR FORCE IN EUROPE

14 September 1944.

My Dear General Terminov.

The following plans for mission to Italy 16 September 1944 are submitted for your information.

PLAN A

|                       |                         |            |
|-----------------------|-------------------------|------------|
| Take off Poltava      | 1030 hours Moscow time. |            |
| Gate out 48°31' N     | 1421 hours Moscow time. | 20,000 ft. |
| KOLONKA 25°12' E      |                         |            |
| Target 48°40' N       | 1528 hours Moscow time. | 20,000 ft. |
| ROMA/CAPRAVA 12°15' E |                         |            |
| Italian bases         | 1830 hours Moscow time. |            |

PLAN B

|                       |                         |            |
|-----------------------|-------------------------|------------|
| Take off Poltava      | 1130 hours Moscow time. |            |
| Gate out 48°33' N     | 1506 hours Moscow time. | 20,000 ft. |
| KOLONKA 25°03' E      |                         |            |
| Target 48°32' N       | 1507 hours Moscow time. | 20,000 ft. |
| ROMA/CAPRAVA 12°15' E |                         |            |
| Italian bases         | 1830 hours Moscow time. |            |

|                       |                         |            |
|-----------------------|-------------------------|------------|
| Take off Poltava      | 1045 hours Moscow time. |            |
| Gate out 48°33' N     | 1416 hours Moscow time. | 20,000 ft. |
| KOLONKA 25°03' E      |                         |            |
| Target 48°32' N       | 1507 hours Moscow time. | 20,000 ft. |
| ROMA/CAPRAVA 12°15' E |                         |            |
| Italian bases         | 1830 hours Moscow time. |            |

Sincerely,



WILLIAM J. ...  
 Major General, Air Corps,  
 Chief of Staff

"A"

Pefferen Mik  
 Date at 4981 - 2312 Janbor 1145 M -  
 4900 - 2114  
 437 - 1846 I.P.  
 4440 - 1815 Ten. MOR/OSTRAVA 1028  
 4433 - 1744 R.P.  
 4307 - 1605 coast y.  
 fuggien - 1830 M

B

Mik.  
 4833 - 2033 gate out. Katosmyja 1249 - 1230  
 4704 - 2212 1506 - 1150  
 4113 - 2132 T.P.  
 4732 - 2138 Ten. VEDRELEN 1607 M -  
 4741 - 2130 R.P.  
 4312 - 1633 coast y.  
 fuggien - 1830

C.

Mik.  
 4833 - 2003 gate out 1201  
 4643 - 1717 1418  
 4637 - 1635 I.P.  
 4716 - 1638 Ten. SZOMBATHELV 1620  
 4717 - 1612 R.P.  
 4301 - 1605 coast y -  
 fuggien 1830

HEADQUARTERS EASTERN COMMAND, U.S. STRATEGIC AIR FORCES IN EUROPE  
 ROUTING MESSAGE

|                          |                                       |
|--------------------------|---------------------------------------|
| PRECEDENCE               | DEP. CMDR'S INITIALS                  |
| CLASSIFICATION<br>SECRET | ORIGINATOR                            |
| DATE<br>14 Sept 44       | DEPUTY CMDR FOR OUR DUTY O'S INITIALS |
| SERIAL NR                | TIME CLRD.                            |

TO:

NO INFORMATION RECEIVED BY THIS HEADQUARTERS OR RUSSIAN AUTHORITIES  
 REHRAD XRAY KASY DASH TWO ZERO ONE ONE PAREN BAKER FOR TRAINING FROM  
 WALSH TARE \_\_\_\_\_ PAREN SOVIETS ARE CHECKING ALL POSSIBLE  
 SOURCES OF INFORMATION PD YOU WILL BE ADVISED IF ANYTHING IS LEARNED



REFERENCES:

THE MAKING OF AN EXACT COPY OF THIS MESSAGE IS FORBIDDEN. ONLY SUCH  
 EXTRACTS AS ARE ABSOLUTELY NECESSARY WILL BE MADE AND PROPERLY

CLASSIFIED  
 0 4 5 8

PRIORITY  
CONFIDENTIAL  
14 SEPT 1944

OPERATIONS

BOM

FOLLOWING FIGHTER CALL SIGNS WILL BE USED BY FRANTIC SEVEN:

FIGHTER COMMANDER - UNCLE  
FIGHTER SQUADRONS - FALCON  
CUSTARD  
BENTLY  
BORAX

PLEASE ACKNOWLEDGE

WALSH

T-758



0459

PRIORITY  
CONFIDENTIAL NEEDS

OPERATIONS

14 SEPT 1944

REV ALO

THIS PAGE CONTAINS THE CALL SIGN WHICH HAS NOT YET BEEN

ACKNOWLEDGE

14 SEP

T-751



0460

SEPT 13, 1944

CONFIDENTIAL - THIS MESSAGE IS BEING TRANSMITTED IN PLAIN  
TEXT AND SHOULD BE KEPT SECRET. IT CONTAINS INFORMATION OF  
A LIMITED NUMBER OF PERSONS ONLY. YOU SHOULD NOT DISCLOSE IT  
TO ANY OTHER PERSONS UNLESS YOU ARE SPECIFICALLY INSTRUCTED  
TO DO SO. IF YOU ARE NOT SURE OF THE INSTRUCTIONS TO BE  
FOLLOWED, YOU SHOULD CONTACT THE OFFICE OF THE DIRECTOR OF  
COMMUNICATIONS.

ASSUME

0 4 6 1

PRIORITY

~~SECRET~~  
13 SEPTEMBER 1944

DEPUTY COMDR FOR OPS

SPECIAL MISSION HAS BEEN APPROVED BY LOCAL SOVIETS FOR ONE FOUR SEPTEMBER  
PD TO DEANE FROM WALSH TOPSEC TARE SEVEN ONE SEVEN PD  
SPAATZ HAS BEEN NOTIFIED PD I UNDERSTAND FLIGHT PLANS HAVE BEEN SUBMITTED  
TO GENERAL KOROLENKO CMA IF FOR ANY REASON YOU URGENTLY REQUIRE FLIGHT  
PLAN SUGGEST CONTACT HIM OR IF STILL DESIRED CAN SEND



0 4 6 2



HEADQUARTERS EASTERN COMMAND, U.S. STRATEGIC AIR FORCES IN EUROPE  
 MIGRATING MESSAGE

|                |                   |                      |
|----------------|-------------------|----------------------|
| PRECEDENCE     | SECRET            | DEP. CMDR'S INITIALS |
| CLASSIFICATION | <del>SECRET</del> | ORIGINATOR           |
| DATE           | SEPT 15           | DUTY O'S INITIALS    |
| SERIAL NR      | 8-715             | TIME CLRD.           |
| TO:            | JARR              |                      |

NEURAD MIKE TWO ZERO NINE FOUR FIVE  
 SEND FROM SPARTZ PAREN/TO DEANE FROM WALSH TAKE SEVEN ONE THREE PAREN INDICATES  
 SPECIAL MISSION UNTIL FOURTEENTH SEPTEMBER POSTPONED

~~SECRET~~



REFERENCES:

THE MAKING OF AN EXACT COPY OF THIS MESSAGE IS FORBIDDEN. ONLY SUCH  
 EXTRACTS AS ARE ABSOLUTELY NECESSARY WILL BE MADE AND PROPERLY  
 CLASSIFIED

0463

HEADQUARTERS EASTERN COMMAND, U.S. STRATEGIC AIR FORCES IN EUROPE  
 ( ) URGENT MESSAGE

|                                |                      |
|--------------------------------|----------------------|
| PRECEDENCE                     | DEP. CMDR'S INITIALS |
| CLASSIFICATION<br>OPS PRIORITY | ORIGINATOR           |
| DATE<br>13 SEPTEMBER 1944      | DELEGATIONS          |
| SERIAL NR<br>1                 | DUTY O'S INITIALS    |
|                                | TIME CLRD.           |

TO:

CLEARANCE FOR FRANTIC SEVEN FLIGHT PLAN AS SUBMITTED BY EIGHTH AIR  
 FORCE PRN TO SPAATZ FROM WALSH TOP SECRET TARE \_\_\_\_\_ PDM  
 HAS BEEN APPROVED BY SOVIETS FOR ONE FOUR SEPTEMBER 40 EASTCOM READY  
 OKAY

T 712

R  
 13 SEP 1944  
 1000H  
 BY

REFERENCES:

THE MAKING OF AN EXACT COPY OF THIS MESSAGE IS FORBIDDEN. ONLY SUCH  
 EXTRACTS AS ARE ABSOLUTELY NECESSARY WILL BE MADE AND PROPERLY  
 CLASSIFIED

0464

~~SECRET~~  
HEADQUARTERS  
EASTERN COMMAND  
USSTAF

12 SEPTEMBER 1944.

MY DEAR GENERAL PERMINOV:

FRANTIC SEVEN (7) HAS BEEN POSTPONED. FLIGHT PLAN PREVIOUSLY  
SUBMITTED TO YOU WILL BE EXECUTED ON 14 SEPTEMBER 1944.

ALL DETAILS OF FLIGHT PLAN WILL REMAIN THE SAME.

THOMAS K. HAMPTON,  
LT COLONEL, AIR CORPS,  
DEPUTY CMDR FOR OPERATIONS.



~~SECRET~~  
0 4 6 5

URGENT

WELSH

CONFERENCE WITH BRIGADE ARMY AIR SEVEN NINE ONE TWO THREE FOUR FROM  
EIGHT AIR FORCE HAS BEEN SUBMITTED FOR SOVIET CLEARANCE THIS MISSION  
AND IF NOT OBTAINED BY ROSSIA. NEGATIVE POSSIBILITY NO DIRECT ANSWER WILL  
BE GIVEN TO WARRIOR TO DEPART FROM WALKER TANK  
WARRIOR YOU WILL BE NOTIFIED WITH INFORMATION AS TO CLEARANCE  
IS AVAILABLE AND PRAGUE AIR DEPARTS SEPTEMBER ONE THREE FOR ITALY  
BTZ ZERO FIVE ONE FIVE TWO



0 4 6 6

~~SECRET~~  
HEADQUARTERS  
EASTERN COMMAND  
U S STRATEGIC AIR FORCES IN EUROPE

12 September 1944.

My Dear General Perminov.

The following schedule for Prantic 7, which will  
depart England 13 September, is as follows:

The force will consist of 100 B-17s and 64 P-51s,  
which will depart the English Coast at 0900 hours Moscow time.

|               |          |          |          |             |           |
|---------------|----------|----------|----------|-------------|-----------|
| Target        | WARSAW   |          | 1355 hrs | Moscow time | 10,000 ft |
| Russian Front | 52°27' N | 21°19' E | 1405 hrs | " "         | 10,000 ft |
| Poltava       |          |          | 1720 hrs | " "         |           |

Sincerely,

T.E. HAMPTON,  
Lt Col., A.C.,  
Deputy Comdr for Ops.



~~SECRET~~  
HEADQUARTERS  
EASTERN COMMAND, USSTAF

12 September 1944

General Perminov  
VVS headquarters  
Soltava

Dear General Perminov:

I have just received a radiogram from General Spaatz indicating that mission designated as Frantic 7 and consisting of 100 bombers is planned to arrive here September 13. The flight plan is being plotted now and will be submitted formally as soon as information is available.

The advance notice received just ahead of the flight plan stated that the purpose of the mission was to drop supplies at Warsaw.

B. L. WALSH,  
Major General, USA  
Commanding



~~SECRET~~  
0 4 6 8

22 August 1944  
1730 Hours

Subject: Generalessler's Office

Generalessler  
Generalessler  
Jr., Lt. Colonel

Intercom: Lt. Colonel

Part I

Generalessler came to Generalessler's office to give information about results of, given to him by Colonel Miller. He reported on all the targets and gave the following information: (a) South of Generalessler, (b) West of Generalessler, (c) East of Generalessler - the lines were to be passed at five o'clock (DWD) for the morning. After that reaction was called Generalessler had a little time to go, but of which he gave some targets that would like us to look out later than 24 August. The targets Generalessler mentioned were railroad junctions at Volots - Volots, shipping on the river at the same point, also he mentioned railroad line for the Volots. Generalessler said that they have information that the Germans have a lot of military equipment at these junctions, with which they are trying to transport and stock of equipment up to the river started by the Volots - Volots front. Generalessler said he thought the most important as the latest data he to be ahead of the Russian river. Generalessler agreed on the importance of the targets and he will get in touch with Generalessler, but he thought that it would be possible to accomplish the mission by 24 August. Generalessler asked Generalessler to get in touch with Generalessler and to look with the map to give us the latest data possible for the mission.

Part II

Generalessler came with Generalessler was called by Generalessler at 1730 - at which Generalessler pointed out the advantages of having certain areas along the river given by Generalessler or Generalessler. Generalessler went to Generalessler at the air station and was told to get in touch with Generalessler and to look with the map to give us the latest data possible for the mission. Generalessler said that he would get in touch with Generalessler and to look with the map to give us the latest data possible for the mission.



0469



conference, Oct. 11....Cont'd.

General Leaker and I have come to a final decision that the target at Salotti would be the northern part of the marshalling yards marked (2) on Target Chart # 11-51-7A, that the target at Salotti to be the port area and the northern end of marshalling yards. The target at Caserta marshalling yards is on the southern side of the city. General Leaker said that he would radio immediately to General Speiss and said he thought it would be a perfect job for our Air Force in Italy. General Leaker expressed his opinion that this target might be more important than Target #6. General Leaker again asked General Speiss to keep in touch with him as to how late we could reach the above targets.

0 4 7 0

HEADQUARTERS  
EASTERN COMMAND  
USSTAF  
OUTGOING MESSAGES

PRECEDENCE ROUTINE  
CLASSIFICATION ~~SECRET~~

*[Handwritten signature]*

GEN KERRILL  
ORIGINAL  
*[Handwritten initials]*  
APPROVED, ASSISTANT.

DATE 23 AUGUST 64

SRL NR  
JE 2065 TO: JESS

*OUTGOING*

(RELAY THE FOLLOWING TO MESSAGES WITH THE ADDED INFORMATION)

ONLY FOR YOUR INFORMATION FORWARD TO HQS. SENT TO YOU BY PAPER BOARD  
FOR THE BUREAU AND THE 1ST AIR FORCE HQS. L.A. SIGN. S. WALKER CITY. T.P. ROBERT J. KING  
TO HQS. AIR FORCE BOARD HQS. CIVIL AIR BOARD HQS. AIR FORCE BOARD HQS. AIR FORCE BOARD HQS. AIR FORCE BOARD  
TO HQS. AIR FORCE BOARD HQS. CIVIL AIR BOARD HQS. AIR FORCE BOARD HQS. AIR FORCE BOARD HQS. AIR FORCE BOARD  
TO HQS. AIR FORCE BOARD HQS. CIVIL AIR BOARD HQS. AIR FORCE BOARD HQS. AIR FORCE BOARD HQS. AIR FORCE BOARD

*[Handwritten mark]*



THE MAKING OF AN EXACT COPY OF THIS MESSAGE IS FORBIDDEN. ONLY SUCH EXTRACTS AS ARE ABSOLUTELY NECESSARY WILL BE MADE AND PROPERLY CLASSIFIED.

0471

HEADQUARTERS  
EASTERN COMMAND  
USSTAF  
OUTGOING MESSAGES

PRECEDENCE URGENT  
CLASSIFICATION

COLONEL HAMPTON  
OPERATIONS  
ORIGINATOR

DATE 22 AUGUST 1944

APPROVED, ADJUTANT.

SRL NR  
T-204 TO: JJHL JJCQ

FROM SOVIETS FOLLOWING TARGETS HAVE BEEN REQUESTED FOR ATTACK ON OR BEFORE TWO FOUR AUGUST PD TARGET ONE COLON GALATZ CMA CHART NUMBER ONE ONE DASH FIVE ONE DASH NAN ABLE CMA MARSHALLING YARD NUMBER TWO REPEAT TWO TO RECEIVE MAXIMUM EFFORT WITH PREFERENCE TO NORTHERN PORTION OF TARGET PD TARGET TWO COLON BRAILA CMA CHART NUMBER ONE ONE DASH FIVE TWO DASH NAN ABLE CMA MAIN EFFORT IN MARSHALLING YARD AND PORT AREA WITH PREFERENCE TO NORTH PART OF MARSHALLING YARD PD TARGET THREE COLON BUZAN CMA CHART NUMBER ONE ONE DASH ONE TWO NAN ABLE CMA TO HIT MARSHALLING YARDS ON SOUTH OF TOWN PD ROUTE FROM ABOVE TARGETS TO CROSS FRONT LINE SOUTH OF ODESSA OVER SEA AT OVER FIVE THOUSAND XXXX ALTITUDE PD RUSSIANS ADVISE DUE TO THEIR ADVANCE IN THIS AREA THAT RAILS AND PBRTS ARE CARRYING HEAVY LOADS OF EVACUATING ENEMY PD IF PLAN TO STRIKE THE ABOVE TARGETS CAN NOT BE LAID ON BY TWO FOUR AUGUST REQUEST THAT EASTERN COMMAND BE ADVISED DAILY AS TO WHEN THESE XAR TARGETS CAN BE HIT PD SOVIET ADVANCE IN THIS AREA MAKES CLOSE COORDINATION NECESSARY PD PAREN SPAATZ EAKER AND THINING FROM KESSLER SIGNED WALSH TOP SECRET TARE TWO NINE FOUR PAREN NEW SUBJECT PD PLANS CONTEMPLATED IN YOUR CHARLIE SUGAR ONE TWO FIVE EIGHT NAN TARE ARE APPROVED BY SOVIETS WITH NO PREFERENCE SHOWN PD THEY REQUEST FRONT LINE BE CROSSED ABOVE FIVE THOUSAND FEET AT THE FOLLOWING PLACES COLON NORTHERN ROUTE CROSS AT JAROSLAV CMA CENTRAL ROUTE CROSS AT BOTOSANI CMA SOUTHERN ROUTE CROSS SOUTH OF ODESSA OVER SEA PD SINCE WEATHER CONDITIONS MAY NOT ALLOW FRANTIC SIX THE MAKING OF AN EXACT COPY OF THIS MESSAGE IS FORBIDDEN. ONLY SUCH EXTRACTS AS ARE ABSOLUTELY NECESSARY WILL BE MADE AND PROPERLY CLASSIFIED.

0472

HEADQUARTERS  
EASTERN COMMAND  
USSTAF  
OUTGOING MESSAGES

|                |                   |                     |
|----------------|-------------------|---------------------|
| PRECEDENCE     |                   |                     |
| CLASSIFICATION | <del>SECRET</del> | ORIGINATOR          |
| DATE           |                   | APPROVED, ADJUTANT. |
| SRL NR         | TO:               | PAGE TWO T-294      |

SUGGEST FRANTIC SEVEN FROM ITALY COME NEXT AND THAT THE TARGETS REQUESTED  
BY SOVIETS BE USED BY THEM ON TWO FOUR AUGUST PD REQUEST WE BE IMMEDIATE  
ADVISED OF ACTION TAKEN

~~SECRET~~

THE MAKING OF AN EXACT COPY OF THIS MESSAGE IS FORBIDDEN. ONLY  
SUCH EXTRACTS AS ARE ABSOLUTELY NECESSARY WILL BE MADE AND PROPERLY  
CLASSIFIED.

7 3 0 2  
0 4 7 3

HEADQUARTERS  
EASTERN COMMAND  
USSTAF

21 AUGUST 1944

MY DEAR GENERAL PERMINOV:

1. THE FOLLOWING TARGETS ARE BEING CONSIDERED FOR ATTACK BY FRANTIC SEVEN ON THEIR WAY FROM ITALY.

PLAN A: DOMUMIN AND MORAVSKA OSTRAVA/PRINOST OIL REFINERIES.

PLAN B: DEJ OIL REFINERIES.

PLAN C: MOINESTI AND RANVICULSARAT OIL REFINERIES.

2. MOSCOW SHOULD BE INFORMED THAT WHEREAS THESE ALTERNATE PLANS ARE PREPARED IN EVENT OF POOR WEATHER OVER ONE TARGET, GENERAL EAKER **ALSO** DESIRES TO KNOW SOVIET PREFERENCE OF TARGETS.

SINCERELY

P. T. CULLEN,  
COLONEL, AIR CORPS,  
DEPUTY COMMANDER FOR OPS.



0474

HEADQUARTERS  
EASTERN COMMAND  
USSTAF  
OUTGOING MESSAGES

|                |        |
|----------------|--------|
| PRECEDENCE     | URGENT |
| CLASSIFICATION | SECRET |

P. T. CULLEN, COL., A.C.  
OPERATIONS  
INITIATOR

DATE 20 AUGUST 1964

APPROVED, ASSISTANT.

SRL NR TO: JJHL JDCQ

T-276

DOPE IN YOUR ITEM EASY ONE FIVE EIGHT FIVE NAN TARE CORRECT EXCEPT OUR  
SUPPLY SITUATION INDEFINITE UNTIL AFTER FRANTIC SIX OPERATES PD EAKER  
AND XNRK TWING FROM CULLEN SIGGED WALSH TOP SECRET TARE TWO SEVEN  
SIX PAREN YOU WILL BE INFORMED PRIOR TO FRANTIC SEVEN IF NECESSARY TO  
SEND SUPPLIES FROM ITALY

*Handwritten signature*



THE MAKING OF AN EXACT COPY OF THIS MESSAGE IS FORBIDDEN. ONLY  
SUCH EXTRACTS AS ARE ABSOLUTELY NECESSARY WILL BE MADE AND PROPERLY  
CLASSIFIED.

0 4 7 5



0 4 7 6





0477



0 4 7 8



0 4 7 9

506.963-1  
45/06/24-  
45/07/07

Copy No.

RETURN TO  
AFSHIC  
MAXWELL AFB AL

~~SECRET~~

DECLASSIFIED  
EO 11652

SUPREME HEADQUARTERS

ALLIED EXPEDITIONARY FORCE

MISSION (DENMARK)

<sup>press</sup>  
FORTNIGHTLY REPORT

No. 19

5-993

For Fortnight Ending 7 JULI 1945

~~SECRET~~

1029155

0480

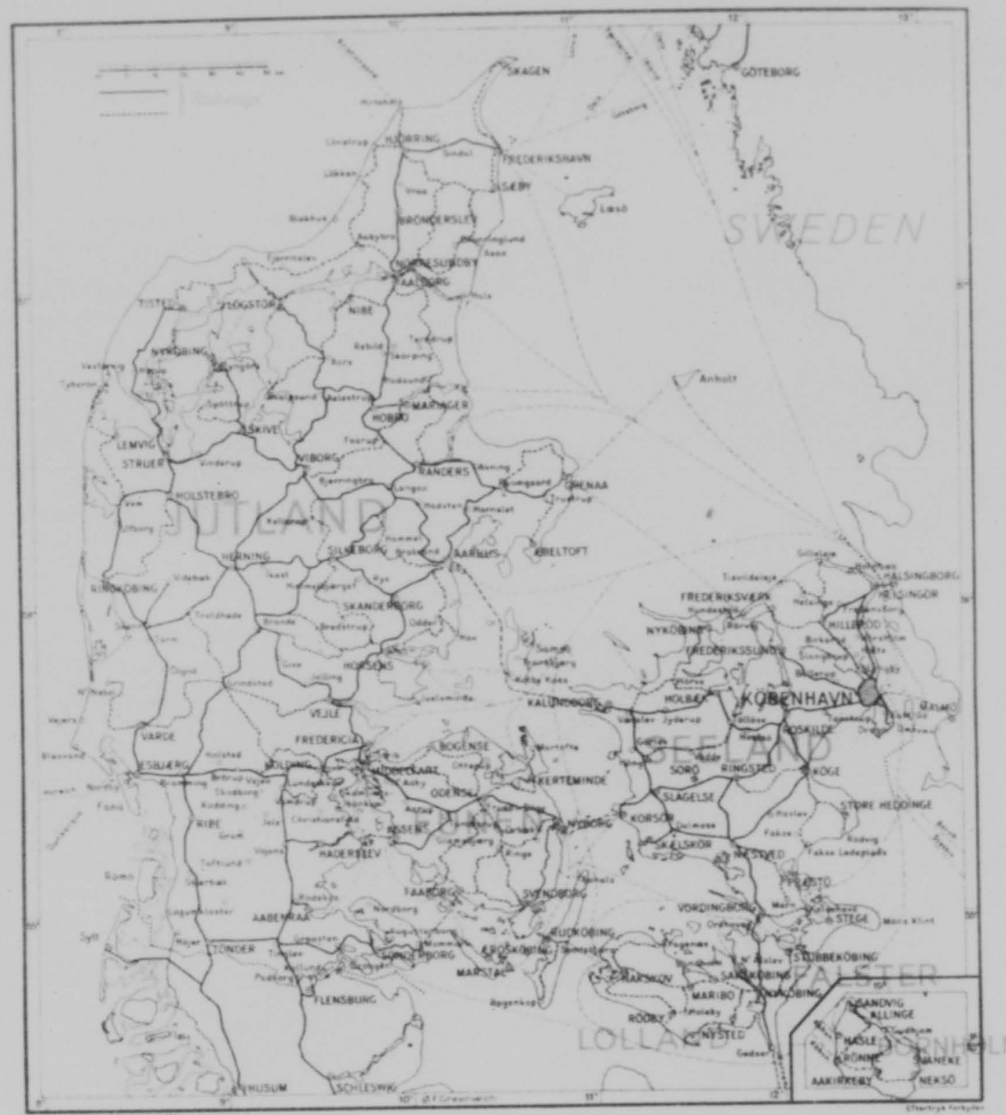

0481

|                   |           |
|-------------------|-----------|
| AFSIRC            | RETURN TO |
| MAXWELL AFB TEXAS |           |
| 506.963-1         |           |
| 45/02/24 -        |           |
| 45/07/07          |           |

~~SECRET~~

DISTRIBUTION

|  | <u>No. of Copies</u> |
|--|----------------------|
| Supreme Headquarters AEF (Main)                |                      |
| Adjutant General                               | 1 - 3                |
| Secretary General Staff                        | 4 - 6                |
| AC of S, G-1 Division                          | 7                    |
| AC of S, G-2 Division                          | 8                    |
| AC of S, G-3 Division                          | 9 - 10               |
| AC of S, G-4 Division                          | 11 - 13              |
| AC of S, G-5 Division                          | 14 - 16              |
| Psychological Warfare Division                 | 17                   |
| Public Relations Division                      | 18                   |
| Signal Division                                | 19                   |
| Engineer Division                              | 20                   |
| Medical Division                               | 21                   |
| Air Staff (Main)                               | 22 - 26              |
| Air Staff (Rear)                               | 27                   |
| Air Defence Division                           | 28                   |
| AWCP (Main)                                    | 29                   |
| AWCP (Rear)                                    | 30                   |
| Political Officer (United States)              | 31                   |
| Political Officer (British)                    | 32                   |
| Supreme Headquarters AEF (Rear)                |                      |
| G-5 Division                                   | 33                   |
| 21 Army Group                                  | 34 - 36              |
| Supreme Headquarters AEF Mission (FRANCE)      | 37                   |
| Supreme Headquarters AEF Mission (NETHERLANDS) | 38                   |
| Supreme Headquarters AEF Mission (BELGIUM)     | 39                   |
| Supreme Headquarters AEF Mission (LUXEMBOURG)  | 40                   |
| Air Ministry                                   | 41                   |
| U.S.S.T.A.F.                                   | 42 - 46              |
| U.S. Strategic Air Forces in Europe            | 47 - 48              |
| Headquarters, 1 Parachute Brigade              | 49                   |
| Supreme Headquarters AEF Mission (DEMARK)      |                      |
| Head of Mission                                | 50                   |
| G1/G2 Division                                 | 51                   |
| G2/G3 Division                                 | 52                   |
| G-5 Division                                   | 53                   |
| IR/TW Division                                 | 54                   |
| Naval Component                                | 55                   |
| Air Component                                  | 56                   |
| Military Attache's Staff                       | 57                   |



506.963-1  
5/22/24 -  
45/07/07

RETURN TO  
THIRD  
AWELL AVENUE

~~SECRET~~

DISTRIBUTION

|  | <u>No. of Copies</u> |
|--|----------------------|
| Supreme Headquarters AEF (Main)                |                      |
| Adjutant General                               | 1 - 3                |
| Secretary General Staff                        | 4 - 6                |
| AC of S, C-1 Division                          | 7                    |
| AC of S, C-2 Division                          | 8                    |
| AC of S, C-3 Division                          | 9 - 10               |
| AC of S, C-4 Division                          | 11 - 13              |
| AC of S, C-5 Division                          | 14 - 16              |
| Psychological Warfare Division                 | 17                   |
| Public Relations Division                      | 18                   |
| Signal Division                                | 19                   |
| Engineer Division                              | 20                   |
| Medical Division                               | 21                   |
| Air Staff (Main)                               | 22 - 26              |
| Air Staff (Rear)                               | 27                   |
| Air Defence Division                           | 28                   |
| AWCP (Main)                                    | 29                   |
| AWCP (Rear)                                    | 30                   |
| Political Officer (United States)              | 31                   |
| Political Officer (British)                    | 32                   |
| Supreme Headquarters AEF (Rear)                |                      |
| C-5 Division                                   | 33                   |
| 21 Army Group                                  | 34 - 38              |
| Supreme Headquarters AEF Mission (FRANCE)      | 39                   |
| Supreme Headquarters AEF Mission (BELGIUM)     | 40                   |
| Supreme Headquarters AEF Mission (NETHERLANDS) | 41                   |
| Supreme Headquarters AEF Mission (DENMARK)     | 42                   |
| Air Ministry                                   | 43                   |
| U.S.S.C.A.F.                                   | 44 - 46              |
| U.S. Strategic Air Forces in Europe            | 47 - 48              |
| Headquarters, 1 Parachute Brigade              | 49                   |
| Supreme Headquarters AEF Mission (DENMARK)     |                      |
| Head of Mission                                | 50                   |
| G1/G2 Division                                 | 51                   |
| G2/G3 Division                                 | 52                   |
| C-5 Division                                   | 53                   |
| FP/W Division                                  | 54                   |
| Naval Component                                | 55                   |
| Air Component                                  | 56                   |
| Military Attache's Staff                       | 57                   |

1029155

0483



SUPREME HEADQUARTERS  
ALLIED EXPEDITIONARY FORCE  
MISSION (DEBARK)

OCS/13.

7 July, 1945.

SUBJECT : Fortnightly Progress Report No. 12

In accordance with Supreme Headquarters AEF letter AGO91  
112-2 OCS-45 dated 29 October, 1944, I submit Fortnightly Progress  
Reports for the period 24 June, 1945 - 7 July, 1945.

This report is intended for the use and information of the  
person, office or headquarters to which addressed. By direction of  
the Supreme Commander it will not be passed or circulated, in whole  
or in part, outside the staff or headquarters of the addressee unless  
special permission has been received from Supreme Headquarters AEF.

*R. H. Dewing*

/eh.

R H DEWING,  
Major General,  
Head of Mission.

I N D E X

|  | <u>Page</u> |
|--|-------------|
| GENERAL SUMMARY  | 1           |
| By Major General R H DENING, CG, BSO, MC.                          |             |
| APPENDIX 'A' - G-1 SECTION   | 3           |
| G-1 Section  | 3           |
| EWX  |             |
| APPENDIX 'B' - G-2 SECTION   |             |
| Operational Intelligence   | 4           |
| Travel Control   | 4           |
| Frontier Control   | 4           |
| Counter Intelligence   | 5           |
| Censorship   | 6           |
| Public Safety  | 6           |
| APPENDIX 'C' - G-3 SECTION   |             |
| Part I - General   | 8           |
| Part II - Advanced Warfare   | 8           |
| Part III - General Warfare and Evacuation<br>(1 Parachute Brigade) | 9           |
| APPENDIX 'D' - G-4 SECTION   |             |
| G-4 Section  | 11          |
| Movement and Transportation  | 12          |
| APPENDIX 'E' - G-5 DIVISION  |             |
| General  | 13          |
| Supply and Economics   | 13          |
| Finance Section  | 17          |
| Public Health Section  | 19          |
| Refugees and Displaced Persons                                     | 19          |
| Legal Section  | 20          |
| APPENDIX 'F' - PR/PW DIVISION                                      |             |
| Public Relations Section   | 21          |
| Psychological Warfare Section                                      | 21          |
| APPENDIX 'G' - AIR COMPONENT                                       |             |
| R.A.F. Exhibition  | 24          |
| Air Display at Kastrup   | 24          |
| Repatriation of Luftwaffe Personnel                                | 24          |
| Air Transport  | 24          |
| Move to Norway of A.T.I.   | 24          |
| Danish Airfields   | 25          |
| Repatriation of invalid Danish Displaced Persons                   | 25          |
| Visits   | 25          |
| Public Relations   | 25          |
| Unveiling of Memorial  | 25          |
| Air Intelligence   | 25          |
| Personnel  | 25          |
| APPENDIX 'H' - NAVAL COMPONENT                                     |             |
| General  | 26          |
| Disarmament  | 26          |
| Minesweeping   | 27          |
| Supply   | 27          |

SECRET  
 (SECRET)

Program Report No. 19  
 31 Jan 45 - 7 Jul 45.

GENERAL SITUATION.

1. Disolution of SHARP.

As reported a fortnight ago an appreciable reduction in the officers employed with this Mission should now be possible as we are well past the peak of our work. I am however still awaiting instructions as to the future of the Mission when the Combined Command ceases, and can not effect reductions until I know whether the organization which has been recommended from here is approved. Mouth-to-mouth speculations and rumors are rife among the Danish population and an official announcement is overdue.

2. British Troops in Denmark.

The 2nd, K.R. B.C. are due to leave Denmark shortly. The squadrons of the Royals, the only remaining British Army unit, will then each have a very large area in which to supervise and assist in the work which remains to be done.

Brigadier Souright has arrived. His Sub-Area Headquarters personnel are due here shortly. He will then take over from H.Q. 1st Para Brigade, which will leave the country.

3. Evacuation of German Forces.

A appreciable numbers of G.A.F. personnel have been moved out of Denmark during the past fortnight. Their numbers will be further reduced during the coming fortnight.

242,108 German troops have now left Denmark and 51,440 still remain in the country.

The number of German patients remaining in hospitals is 26,000. In addition, there are 3,500 in convalescent camps. During the past week, evacuation of sick and wounded by train and ship has been unavoidably suspended by 21 Army Group, but an early re-opening of evacuation has been promised. The evacuation of medical staff is continuing, 800 being due to leave immediately.

4. Coordination with R.A.F.

Disposal of enemy war material under R.A.F. control needs coordinating with disposal of enemy war material under Army control and with local conditions. This has been put to 2nd T.A.F. and I hope will soon be effected.

5. German Refugees.

The clearing of German refugees from Danish schools etc. all over the country into accommodation in large camps, which is in the hands of Danish authorities, is progressing slowly. The Danish public are becoming increasingly resentful and critical of the number of refugees still occupying buildings needed by the Danes.

6. Enemy War Material.

The Danish Government has been given comprehensive instructions on the destruction of German arms, ammunition and equipment, not required by the Allies and for which no civil use exists. A number of officers and men of the Danish army are being trained in destruction and demolition.

....2

0 4 8 6

- 2 -

At my suggestion, but only after several weeks dallying, the Danish Government has issued an order that all German arms, ammunition and equipment in the hands of the Danish public are to be handed in to the Police and that, after 12th. July, to be in possession of such war material will be a punishable offence. From conversations with several Chiefs of Police in Northern Jutland the amount of material being handed in seems to be small. It remains to be seen whether the Danish Government will allow their order to be disobeyed or whether they will make an effort to clear the country of illicit arms.

#### 7. Danish Army.

British Training teams have now arrived and Danish cadres are forming on 10th. July for the training of units to be formed from the call-up on 18th. July.

The British equipment for the 10,000 men of this call-up has been sent up to Denmark as rapidly as possible after a late start. The difficulties in effecting delivery have been overcome by 'Q' of 21 Army Group sufficiently to avoid our holding up training, which at first seemed likely.

#### 8. Food Report.

During the fortnight ending 4th. July 4,426 tons of butter and 534 tons of eggs were despatched to the U.K. An additional 816 tons of butter and 475 tons of eggs were loaded ready for shipment on 5th. July.

The Wrapper situation is still serious.

Supply of fish to 21 Army Group by road is proceeding satisfactorily.

#### 9. Danish Public Opinion.

During the past fortnight indications of impatience with and criticism of the Allied "control" in Denmark have increased. This has been more apparent in conversation and in letters than in the Press. A number of totally untrue rumours, generally in criticism of the S.M.E.F. Mission, have become current. The background of these stories is "Germany put her heel on Denmark but the Allies sit on her". Some of these tales are conceivably being put about by agencies sympathetic to Germany, though no concrete evidence of this has been obtained.

#### 10. Rest Camps.

No instructions have yet been received as to whether leave camps for British Troops in Germany are to be opened in Denmark. There are many rumours from British sources that camps are to be opened.

*R H Lewing*  
R H LEWING,  
Major General,  
Head of Mission.

APPENDIX 'A'

- 3 -

SECRETSUPREME HEADQUARTERS  
AFM MISSION (DENMARK)Progress Report No. 19  
24 Jun 45 - 7 Jul 45  
G-1 Section  
-----1. Denish Civilians For Conscription in GERMANY

Reference Fortnightly Report Number 18, Appendix 'A', paragraph 1. Agreement in principle to recruitment has been obtained from the Danish Government. Representatives of 21 Army Group have been to DENMARK to gain further information so that a concrete scheme can be drawn up and discussed in detail with the Danish authorities. Meanwhile, Supreme Headquarters AFM G-4 Division has suggested to 21 Army Group that the same system of recruitment in force in HOLLAND and BELGIUM be set up in DENMARK. It is expected that recruiting will begin in the near future and no difficulty is expected in obtaining the numbers required.

2. Welfare

There has been no further progress in regard to Short Leave Centres in DENMARK. Action by 21 Army Group is expected in the near future. Representatives of US Forces have visited DENMARK to explore possibilities of opening leave centres. They have been referred to 21 Army Group, who must be the co-ordinating agency.

3. Demobilization of Danes serving in German Forces

21 Army Group have been addressed on this subject. Only persons of proved Danish nationality should be sent to DENMARK. Cases of doubt should be referred to the Danish Consul at FLORBERG.

FWX4. Russians

Their evacuation is likely to take place within the next week, except for 354 hospital cases which are at present being surveyed and reported upon.

5. Hospital Cases

A full list of other Allied Nations prisoners of war in Danish hospitals is being prepared, showing if:

- (a) Fit to move by normal transportation.
- (b) Fit to move by ambulance train or ship.
- (c) Fit to move by air ambulance.
- (d) Unfit to move.

6. Polen, Baltic States, etc

No action is being taken by FWX in this matter, as they are dealt with by G-5 Displaced Persons Branch and no immediate evacuation is possible.

7. Postings

Major RAYMOND MCKEE (OS13649) and 37617148 Sgt R V HERRERT proceeded to Supreme Headquarters AFM (Main) FWX on 2 July for reassignment and cease to be attached to Supreme Headquarters AFM Mission (DENMARK).

0488

4

SWEDESBOROUGH HEADQUARTERS  
AFS MISSION (DENMARK)

APPENDIX "B"

Progress Report No. 19  
24 Jan 45 - 7 Jul 45.  
G-2 Section  
-----

OPERATIONAL INTELLIGENCEDocuments

1. Orders have been received for SHAEF Document Centre (COPENHAGEN) to leave for GERMANY on 7 July 1945. Their work will be taken care of by Lt FLECK, at present here on duty from 21 Army Group.
2. Plans of Dead End post, telephone and telegraph lines used by the Germans in DENMARK have been received from SHAEF Document Centre for transmittal to the Danish authority.

Technical Intelligence

3. Sqr/Ldr DEVONS of CIOS 21 was assigned on 29 June 45 to discuss with representatives of the Wehrmacht the developments in technical intelligence which have been reported since the start of the war.

Maps

4. Lt ROBERTS, representing the Army Map Service, WASHINGTON, arrived 6 Jul to collect Danish maps which previously had been ordered by Capt HYEMAN, Army Map Service.

T-Targets

5. A total of 127 T targets have been examined to date, of which 56 were opportunity targets. German T-Targets uncovered total 140. Of the total number of targets 104 were of exceptional intelligence value.

TRAVEL CONTROL

6. As a result of instructions from SHAEF the Danish Government have been informed that it is proposed on the termination of Cassin's Command to hand over to the Danish authorities the responsibility for all civilian travel into and out of DENMARK, with the exception of GERMANY, AUSTRIA and Allied Force Headquarters territory, but that an Allied Counter Intelligence check would still be necessary. A subsequent cable from SHAEF has stated that security control of travel into and out of DENMARK will also become a Danish responsibility. SHAEF have been asked to confirm that this means that the only check on persons travelling into and out of DENMARK is that which the Danish authorities may wish to make from the point of view of their own interests. A check from the Allied point of view seems essential.

7. The various Legations in COPENHAGEN are to give visas for travel to their countries. The Norwegian, Swedish and Finnish Legations are granting visas and a small number have already been granted by the Belgian and French Legations. The British Legation is expected to begin granting visas by the middle of July.

8. On the disintegration of SHAEF, AFS Travel Permits will be granted only to civilians travelling on AFS business.

9. AFS Permits have been issued for the period under review as follows:

|                |    |         |   |             |    |
|----------------|----|---------|---|-------------|----|
| UNITED KINGDOM | 22 | BELGIUM | 5 | GERMANY     |    |
| FRANCE         | 5  | HOLLAND | 2 | SWITZERLAND | 30 |

FRONTIER CONTROL

10. As 2 WEC are leaving DENMARK on or about 12 Jul 45 the following arrangements have been made with the Danish authorities reference to the control of the Danish-German Frontier:



- 5 -

- (c) The battalions of the Danish Army with elements of a third battalion, together totalling approximately 1,100 men will take over from Danfors. These battalions are to be under command of Colonel Hove. Their function will be to patrol the frontier and canalise all traffic through the control posts.
- The Frontier Guard (Grense Gendarmet), at present totalling approximately 300 men will also assist in patrolling the frontier. The Danes are endeavouring to increase this force and it is hoped that a figure of 800 frontier guards may be reached by early 1946.
- (c) Detachments of the Volkspoliti (916 men), will assist the Allied Field Security personnel on the crossing posts. It is probable that the Volkspoliti will shortly be transferred back to the National Police (Rigspoliti). The same personnel will, however, remain on the frontier and the change is merely a change of uniform.
- (d) Detachments of the National Police (Rigspoliti) are also present at the crossing posts.
- (e) Customs Officials.

11. Colonel Hove, in addition to commanding the battalions of the Danish Army will also have overall command over all the detachments mentioned in paragraph 10 above. There is therefore one unified command on the Danish side with whom all questions concerning the frontier can be discussed.

#### OTHER MATTERS

12. No major problems have arisen during the period necessitating treatment at a high level. The Danish Security Police has overcome its outstanding difficulties of coordinating the arrest procedure throughout the country and of transferring persons wanted at the Interrogation Centre to DENMARK. A tour of the province by a representative of 21 Army Group on temporary attachment and a representative of the Chief of the Security Police lasted 43 days and revealed several problems, mostly administrative, which are now being dealt with. It is apparent that local police chiefs have had some difficulty in handling and disposing of a number of persons originally arrested by Resistance and named as Allied prisoners of war. Disposal instructions have now been sent out.

13. There are now 14 interrogators working at the Interrogation Centre and some 40 cases have been under investigation during the period. 12 of these have been completed as far as present information allows. The inexperience of a number of the interrogators continues to restrict progress and the disposal of cases. Instruction and training continues.

14. There are at present some 240 persons detained in the Interrogation Centre, of which approximately half are German. The Chief of the Danish State Police and the Chief of the Security Police have inspected the Centre and expressed complete satisfaction with the detention arrangements and the methods of handling detainees.

15. Following the investigation of the activities of the German Red Cross in DENMARK the Danish ARP organisation is now co-operating fully with the Counter Intelligence Sub-section of the Mission and a number of undesirable camp leaders have been removed from German refugee camps. A list of all persons in possession of Red Cross cards is being submitted to the Sub-section and arrangements have been made for all holders to complete the CI Fragebogen. 10 further cards will be issued without reference to the Sub-section.

0 4 9 0



- 6 -

GENERAL

16. On 22 Jan 51, further postal services were restored to DENMARK by the authorization of 20 grams letters to the entire world excluding GERMANY, AUSTRIA, HUNGARY, JAPAN and ITALIAN occupied territory. This has not so far resulted in a large increase in the volume of correspondence, but the proportion of letters to postcards has increased.

- (a) Postal volume averaged 26,500 pieces daily in the fortnight under review, only 4,500 of these being postcards.
- (b) Telegram volume has averaged 4,270 pieces daily being a slight decrease.
- (c) Telephone volume was 1,300 calls daily. NORWEGIAN calls are no longer concerned.
- (d) Owing to the small amount of civilian travellers the Post-Conservancy section still has few customers.

17. The organization of the Conservancy establishment continues to improve. A specialised Section comprising Liaison Languages and Technical Experts has been formed. The Laboratory is still not functioning through lack of trained personnel but permission has just been received for the chief of the Laboratory, Dr. HANSEN to proceed to DENMARK where he will have the work's specialised transfer with British Civil Conservancy. Danish Conservancy work is on a par with the flow of mail which is censored and passed on after the wishes of policy.

18. Table of employment is as follows:

|                    |    |
|--------------------|----|
| Postmaster         | 1  |
| Administrative     | 1  |
| Post 1             | 11 |
| Telecommunications | 11 |
|                    | 24 |

This shows an increase in the Post 1 and Telecommunications staffs.

19. Subdivision Post Conservancy continues to provide material of interest, and there has been an increase in the number of applications from Postal Conservancy corresponding with the increase in the number of letters. Telegram applications have decreased slightly.

SECURITYPolice

20. The Police is slowly but surely returning to its former efficiency. Patrol supplies are now ordered from the Liaison to the Danish Government for Civil Administration and the Liaison is now on restricted and irregular. Reconstruction of the Security Police continues but is not yet satisfactory. Investigation of war crimes is now well under way. The first death penalty was passed on 4 July. Some thousands of records cards of names who have served in the German armed forces have been received from Denmark and will be of material assistance to the Police.

21. The study of war time captured enemy stocks is not yet complete.

22. The third period is characterised by liaison with the, although still not known, tends to increase but the relations between Police and Service Provost Section is excellent and has had good results.

0491

- 7 -

Prison

23. Accommodation is still causing concern. HONGKONG Camp has unfortunately not yet been made entirely available. Further accommodation can however be made available near HONGKONG if water piping can be obtained. A request for this is being examined.

Internal Security

24. No estimate is yet available of the number of arms held by the civil population. An appeal has been made for the surrender of pistols for Allied use. The response to this appeal may give some indication of civilian attitudes.

25. Special internment camps for suspected D.P.'s have not yet been allocated.

0 4 9 2

- 2 -

STAFF HEADQUARTERS  
AIR FORCE (GENERAL)

APPENDIX "A"

Progress Report No. 19  
A. Jul 19 - 7 Jul 45  
C-3 Section  
-----PART IGENERALAttached Troops

1. 21 Army Group have been asked urgently to replace Detachment 200 Lt Coy BASS attached to 1 Parachute Brigade and 1 Airborne Division and make for its release and dispatch to ITALY.

Area for British Police

2. The General Command was requested to ensure that German areas on loan to the British Police were returned by 31 August 1945.

Coastal Batteries

3. As a result of a report from COMNA arrangements were made for the investigation of German coastal batteries although present reports indicate that little important information will be found.

Commanding Staff for GERMANY

4. Conferences were held with 21 Army Group regarding the provision of a Commanding Staff for GERMANY and civilian emergency personnel. The report will be sent to the British authorities as soon as a final official report is received from 21 Army Group.

PART IIINTERPRETER POOLSOrganizationInterpreter Pools

5. In addition to the units it was agreed should be formed (see part 7 Annex C, Report No. 19) a first request has now been made by 21 Army Group to form 2 Interpreter Pools of 100 all ranks each.

U.S. Army

6. The original US on which these units to be formed has now been changed to the US for a U.S. Army as used in other liberated countries.

Equipment

7. It was agreed at the 20th meeting on equipment of liberated newspaper units held in GERMANY on 4 Jul that the personnel of the Allied Interrogation Centre, COMBRIDGE, would be equipped from the allotment of Allied equipment to GERMANY.

8. The position of regards arrival of equipment in GERMANY will be found in Annex D (C-3 Section).

Training of English Light Infantry Battalions

9. 6 Training Teams arrived from 21 Army Group on 4 Jul.

10. Code courses for 300 junior officers and NCOs at COMBRIDGE and for 150 junior officers and NCOs at FREDERICK are to start on 10 Jul and to run for seven days.

0 4 9 3

- 9 -

11. Short courses for 50 Company Commanders and above are to start at COPENHAGEN on 13 Jul and to run for four days.
12. A Mechanical Transport course for Danish Battalion M.T. Sergeants is to start at COPENHAGEN on 10 Jul.
13. Three Training Teams were despatched to FREDERICIA on 7 Jul.
14. Five Training Teams will remain in COPENHAGEN.
15. Training Teams will join garrisons of newly formed battalions on 19 Jul.

#### Mines and Booby Traps

16. All East and Central JUTLAND is now cleared of mines. Approximately 750,000 mines are left in DENMARK. Work is progressing most satisfactorily.
17. Casualties to date - 64 killed, 78 seriously wounded, 108 lightly wounded.
18. All original minefield records have been checked with a duplicate set found in another theatre.
19. Instructions have been given for lifted mines to be exploded where it will not interfere with operations of taking the mines out of the ground.
20. At the Mine School, COPENHAGEN, a number of courses have been run for controllers and about 250 men have been trained during the past three weeks.
21. Over 300 Danish troops have been trained in mine clearance at the Engineer School, DENMARK. These are now working in the WEST Coast of JUTLAND.

#### PART III - GERMAN PERSONNEL AND MATERIAL EVACUATION (1. DEGREE BELIEF)

##### Evacuation of German forces

22. The evacuation of GEF personnel by train still continues.
23. Totals of all forces evacuated up to 6 Jul are given below:

|     |                       |     |     |       |         |
|-----|-----------------------|-----|-----|-------|---------|
| (a) | By road...            | ... | ... | ...   | 204,849 |
| (b) | Wounded by rail       | ... | ... | ...   | 4,390   |
| (c) | Convalescents by rail | ... | ... | ...   | 6,700   |
| (d) | Wounded by sea        | ... | ... | ...   | 7,700   |
| (e) | Convalescents by sea  | ... | ... | ...   | 10,000  |
| (f) | Ex hospital by sea    | ... | ... | ...   | 300     |
| (g) | Infantry by sea       | ... | ... | ...   | 1,000   |
| (h) | Infantry by rail      | ... | ... | ...   | 2,000   |
|     |                       |     |     | Total | 242,108 |

24. Total German forces remaining in DENMARK:

|     |                  |     |     |       |        |
|-----|------------------|-----|-----|-------|--------|
| (a) | Army personnel   | ... | ... | ...   | 10,290 |
| (b) | Wounded...       | ... | ... | ...   | 26,200 |
| (c) | Convalescent     | ... | ... | ...   | 3,000  |
| (d) | Army on land     | ... | ... | ...   | 1,950  |
| (e) | G.A.F. personnel | ... | ... | ...   | 10,300 |
|     |                  |     |     | Total | 51,740 |

0 4 9 4

- 10 -

Security

25. From 1200 hrs to 10 Jan all Germans not in possession of an authorized pass were liable to immediate arrest. This order did not in fact lead to any arrests which indicated that the pass system had been working reasonably well.

Hospitals and Refugee Camps

26. A further extensive search of hospitals in GERMANY has been carried out by units during the last fortnight. A large number of refugee camps have also been visited. No important incidents have been reported. Small amounts of money and arms have been found in a few hospitals which have been previously searched.

Medical

27. The latest medical report is given below:

(a) The number of patients in hospital is now approximately 27,000.

(b) The sailing of all hospital ships and the running of hospital trains has been cancelled as a result of instructions from 21 Army Group to stop the evacuation of all sick and wounded Germans from GERMANY to GERMANY.

(c) The ship "HESPERUS" is being loaded with about 900 ex hospital personnel for KIEL and about 900 medical personnel for HAMBURG. The vessel is expected to sail 7 Jul.

(d) The withdrawal of German-protected personnel who are treating civilian refugees has not yet been achieved and will take some time. The British Civil Air Defence are working on the task of setting up refugee hospitals. When these are working it should be possible to transfer about 1,000 sick refugees who are at present in military hospitals.

The problem is complicated by the occurrence of a minor epidemic of typhoid fever among the refugees.

(e) The closing of German Medical Units continues - during the fortnight a complete hospital unit left by train, a field hospital left by road and 300 unsorted personnel went to HAMBURG by sea, giving a total evacuation of over 1,000 protected personnel for the fortnight.

(f) A store depot for the collection of medical stores and apparatus required for the Allied Air Fleet has been established in GERMANY and already contains a useful amount of material.

(g) Control of British Hospitals has now been established and the Luftwaffe Hospital in GERMANY has been closed.

0495

APPENDIX 'E'

- 11 -

SECRETDEFENSE HEADQUARTERS  
JAP MISSION (DENMARK)Progress Report No. 19  
24 Jul 45 - 7 Jul 45  
G-4 Section  
-----1. Equipment for Danish Army(a) Clothing

Clothing and necessaries have been arriving by air since 26 June. Arrivals have been irregular, for instance on 2 July sixteen half-boxes and five full-boxes arrived, while on 5 July only two D-7s. Total issue is scheduled to be completed by 12 July. Difficulty is being experienced by non-receipt of copies of the issue vouchers, No. 6 copies, until several days after arrival of stores, and then not entirely complete.

(b) Other Equipment

Five railway wagons containing part of the arms and ammunition issue have arrived. Here again, no issue voucher copies have been received and therefore it is not possible to check. Two of the trucks contained .303 ammunition, one of which was an open truck, but fortunately only one box was broken into and only a small quantity stolen. The axle of the other ammunition truck was broken but here again one box of ammunition broken into.

(c) Courses

As the Danish Army will carry out their own maintenance, instruction is being arranged for the QMs on method of commanding stores. This course will start when the various documents asked for have been received.

(d) Vehicles

Fifty 3-ton lorries and 60 motor-cycles were collected from WAGONS.

2. Issue of Arms for Danish Police

The required arms have been collected, with the exception of sub-machine guns, and issue is taking place, on temporary loan, which is being called in on 31 August.

3. Newspapers for Allied Troops in DENMARK

21 Army Group were requested to hasten the delivery of LONDON newspapers for Allied troops in DENMARK, where newspapers can be bought in civil shops on the day of printing. 21 Army Group have replied that this cannot be arranged for British troops at present, which means that they will continue to get their papers two or three days after the Danish civilians get them. However, 21 Army Group have stated that delivery on day of issue may be arranged at a later date when they are able to alter the method of despatch from UK. No estimate of when this is likely to occur has been given.

0 4 9 6

- 12 -

4. Empty War Material

(a) Arrangements have been concluded by the Royal Navy to form an ammunition dumping ground at sea. Surplus Army ammunition is being concentrated near ports to facilitate shipment.

(b) A week's course is being held, starting 8 July, to train Danish officers and men in method of destruction of ammunition.

5. Procurement

(a) Danish Government has increased ration of duty-free beer for Allied troops in DENMARK to scale of one bottle per man per day. Issue is still made through WAFI channels.

(b) Ministry of Foreign Affairs (Office for Special Commercial Affairs) has now agreed to publishing a decree giving wider publicity to system whereby urgent local purchases up to Kr. 100 may be made from Deprest.

MOVEMENT AND TRANSPORTATION6. Rail

Instructions have been received from Supreme Headquarters ABE for the disposal of empty rail stock and two train loads of empty wagons have already been collected from the frontier. After further signals had been exchanged it was agreed that the 115 empty tank wagons should be retained in DENMARK.

Agreement has been reached with 21 Army Group to accept two hospital trains weekly, but this has now been held up temporarily as all hospitals appear to be full in SCHLESWIG-HOLSTEIN.

Arrangements had been made to have some 6,000 Russians to LUBEK, but this has also had to be cancelled due to lack of accommodation.

7. Shipping

The "ATLANTIC COAST" arrived from UK with 950 tons of POL.

The "HESTER" sailed to HAMBURG with 1,000 German protected personnel and the "HERCULES" is due to sail shortly with 1,000 German convalescents for KIEL and 1,000 protected personnel for HAMBURG.

Arrangements had been made with 21 Army Group to sail two hospital ships weekly to COPENHAGEN, but this is held up temporarily for lack of hospital accommodation in the COPENHAGEN area.

8. Movement by Air

The following displaced persons have been moved to BRUSSELS/PARIS:

|         |     |
|---------|-----|
| French  | 430 |
| Belgian | 500 |
| Dutch   | 50  |

and 80 Norwegians to OSLO.

0497



- 13 -

APPENDIX 11  
11/11/11REPORT HEADQUARTERS  
AFS MISSION (DENMARK)Progress Report No. 13  
Data from 24 June to 7 July 1945  
G-5 DivisionGENERAL.Press Conference.

On 28th June 1945, Brigadier W. L. F. Crowe M.C., Head G-5 Division, held a Press conference with representatives of the Danish press, at which they were invited to submit questions. Heads of sections of G-5 Division were also in attendance.

1. Brig Crowe made a statement to the press in which information was given on the following subjects:

(a) Imports and Exports

Discussions have been held with the Danish Government as to what commodities should be imported under authority of DAFS, and on the export of Danish Agricultural surpluses. Statistics were given of imports and exports already made to date.

(b) Finance

Statistics were given on the recovery of Kroner from Germans and of captured German stores and supplies, a considerable volume of which have been turned over to the Danish authorities.

(c) Refugees and Displaced Persons

Figures were given of the numbers of displaced persons already re-registered and details of the registration and concentration of German refugees.

(d) Public Health

All German refugees in Denmark have now been inoculated against typhoid, para-typhoid, dysentery, and diphtheria. In a week's time the whole programme of inoculation will be completed.

REPORT TO ECONOMIC SECTION1. General

The Mission is continuing its attempts to educate the DANISH public on the subject of government controls as exercised in the United Kingdom, in order to demonstrate that Denmark is not the object of a discriminatory policy.

On 22 June, a meeting was held of representatives of DANISH Trade Associations, who were addressed by the British and U.S. Economic Advisers on the subject of export and other controls in their respective countries. In the discussion which followed, it developed that many erroneous ideas of procedure existed in consequence of commercial firms in those countries offering goods to DANISH concerns without proper stress on the necessity of export licenses.

The press conferences held by Head, G-5 Division, also stressed the present impracticability of securing materials and commodities from GERMANY, so that comprehensive newspaper dissemination of this information was secured. An immediate

0 4 9 8

- 14 -

result was a cessation in the stream of orders and telephone messages requesting the Mission to secure items from GERMANY, demonstrating that the commercial public had read and understood the interview. The subject, however, is still a very live one, as substantial amounts of goods were on order at the time of the capitulation, and a considerable number of items had been paid for in advance.

It is hoped that a means may soon be found of securing especially manufactured items which exist in GERMANY. Requests for machinery made to fit special installations, gasoven linings, etc., are very live items to DANES who must otherwise close down their plants or who cannot put almost completed plants into operation.

Other items of general interest are that the rate of exchange is still undetermined, so that food prices have not yet been set for international exchange; that industrial activity remains about the same, with unemployment practically stationary; and that unofficial reports continue to indicate that full use is not being made of food surpluses because of transportation lacks, although it is believed that most of the surpluses are in types of food which are not capable of transport to other areas.

The DANISH Government has decided against requesting any GERMANY Prisoners of War for rehabilitation work, notifying the Mission accordingly.

### 2. Labour/Unemployment

A small amount of labour unrest is coming to the front, and the Royal Danish Government has found it necessary to impose some fines on violators of the non-strike laws. So far, comparatively small numbers of workers have been involved.

Employment figures as of 31 May indicate that totally unemployed persons increased in number from 49,069 to 49,237. Workers receiving assistance because of short working hours are practically unchanged in number. The greatest changes within classifications are:

Labourers - decrease in unemployment from 33,756 to 29,793.  
Metalworkers - unemployment rose from 9,556 to 10,795.

### 3. Transportation

(See report on Transportation under C-4 Division)

### 4. Price Control & Rationing

Nil.

### 5. Local Procurement

(See report under "Food & Agriculture" - para 6)-

### 6. P. O. L.

Stocks of POL as of 15 June amounted to 3651 tons, of which about half were lubricants. The stocks amounted to 58% of stocks on hand as of 1 May 45.

Receipts of POL to the end of the period covered by this report have been 13,907 long tons. CRAC Copenhagen is turning over to the Mission, for transfer to the DANISH Government, the lubricating oil cargo of SS "Benjamin Shastard" which was assigned to him, amounting to about 1,100 tons. Loading notices has been received of the SS "France Guste", which will bring 12,000 tons. These actual and anticipated receipts, plus early delivery of petroleum special oils, will meet the first three months' requirements.

0499

- 15 -

500 tons of German Navy Fuel oil were released by Property Control for kerosene purposes. Further stocks of captured benzine and oil are expected to be released to the DANISH Government in the near future.

August requirements, plus estimated five months' requirements, have been forwarded for allocation. These include oil to replace coal in electricity production.

The Cement Industry is being studied with a view to converting Coal-fired Kilns to oil-burners, the object being to supply 21 Army Group with Cement.

#### 7. Solid Fuels

Allocations of Coal to DENMARK for July now amount to 61,000 tons, including some 3,000 tons of badly-needed Foundry Coke.

The peat-cutting season is in full swing in all parts of DENMARK. Transport of peat, however, is offering many difficulties due to lack of tyres, spare parts, and petrol. It is hoped that receipt of these supplies will permit free movement before cold weather, as householders and many industries will be dependant upon peat during the coming winter.

#### 8. Food & Agriculture

Representatives of the Dutch Government, interested in DANISH surplus seeds, have arrived in Copenhagen to discuss this and other economic matters.

A revision of the list of foodstuffs shipped to NORWAY for the period 18 May to 1 June brings the total to 19,330 tons instead of 15,546.4 tons reported in the last fortnightly Report. In addition, substantial quantities have been collected and shipped as gifts. Information is now being sought on shipments to NORWAY for the balance of June.

#### 9. SHARP Supply Program

The situation is as follows, amounts in MET:

| ITEM          | AMOUNT          |                           | TOTAL RECEIVED TO DATE |
|---------------|-----------------|---------------------------|------------------------|
|               | ORDERED FORWARD | RECEIVED 21 JUNE - 4 JULY |                        |
| Coal          | 13,961          | 654.0                     | 7,561.0                |
| POL           |                 |                           |                        |
| Petrol        | 6,450           | 3,010.2                   | 3,840.9                |
| Diesel Oil    | 12,500          | 4,693.4                   | 5,651.6                |
| Kerosene      | 6,100           | 3,411.9                   | 3,766.7                |
| Lubricants    | 3,775           | 39.1                      | 645.2                  |
| Petrol Spirit | 950             | -                         | 67.0                   |
| Other         | 800             | -                         | -                      |
| Binder Twine  | 3,000           | -                         | 470.7                  |
| Salt          | 18,000          | 6,500.0                   | 13,798.0               |

Spot Demands for the following items have been forwarded:

Calcined Soda  
 Railway Repair Material  
 Lantern Glasses and Lenses for Mercantile Fleet  
 Silicate Bricks for Gas Works  
 5 tons DDT or 50 tons 10% DDT or 100 tons 5% DDT

The following items allocated to DENMARK are now not required and cancellation of allocation has been requested:

|                                 |       |     |
|---------------------------------|-------|-----|
| Coffee.....                     | 2121. | MET |
| Soap.....                       | 1385. | "   |
| Telecomm stores.....            | 159.2 | "   |
| Veterinary supplies.....        | 34.8  | "   |
| Medical Supplies.....           | 142.8 | "   |
| Soap for September/November ... | 1385. | "   |

0500

10. Food Surpluses

- 16 -

(a) General.

Over the 4-week period ending 4 July 45 a total of 15,311 metric tons of Foodstuffs have been shipped, of which 77% went to Ministry of Food and 23% to U.S. Army. This apparent unequal distribution between the two agencies is explained by the lack of refrigerated shipping space to enable U.S. Army shipments to go direct to inventory.

The latest system of allocation discussed in London by War Office and Ministry of Food and U.S. Army Representatives is that, during the military period, there will be a three way split of the food surpluses, i.e.

One third to British Army  
One third to U.S. Army  
One third to Civil Affairs.

Adjustments are being made over the next few weeks so that overall tonnages shipped during the whole period approximate this distribution.

(b) 21 Army Group

Plans are being made to ship certain foodstuffs every week to 21 AG direct. 90 tons of fresh fish left KOBLENZ on 30 June for Hanover and Hamburg. During the next two weeks, the quantity will be increased to 261 tons in two deliveries, this rate to be maintained over the subsequent weeks. Butter cannot be sent until arrangements can be made for packaging. Pork can be sent only if the Danish Government can release fresh pork in lieu of brine cured bacon. Eggs will be delivered regularly (about 80 tons weekly).

(c) Holland

Through COMEF Mission Netherlands the Danish Government are sending 40 tons fresh fish weekly to ROTTERDAM, Holland, during the month of July. Prices and payment will be agreed later as between the Danish and Dutch Governments.

A shipment consisting of

250 tons butter  
200 " bacon  
150 " eggs

will leave for Holland next week in the Dutch ship "Pezma". This shipment will be regarded as a normal export, and the quantities will be taken from the Ministry of Food's allocation.

(4) The steamer "Corryvreckan" is now due, and will load 2,000 tons of bacon. A second ship has been called for by the Ministry of Food representative here, also sufficient wrappers for the remaining 1,500 tons bacon.

(e) Shipping

Foodstuffs now proceed to U.K. independently.

11. Civil Import Programme.

In response to COMEF cable B-92604, of 21 June, the Danish Government were asked verbally by letter dated 28 June 45 to request the termination of COMEF chairmanship of the Four-Party Committee. A reply is wanted. The British Economic Adviser has just returned from Oslo, and the fifth and last meeting of the Four-Party Committee (OSLO) will be held shortly. Suitable military

4 7 0  
0 5 0 1

- 17 -

representation on the new Three-Party Committee will be arranged to cover the transition period.

12. Postal, Seafarers and Railroads.

Extensions in the communications services have been authorized to include the following:

POSTAL

20 grams letter service between Denmark and the entire world except Germany, Austria, Hungary, Japan and Japanese Occupied Territory.

Letters will be restricted to personal, family or commercial non-transactional matters.

Parcel post between Denmark - Norway/Sweden.

TELEPHONE

Radio Telephone service between Denmark and the U.K. has been authorized but is not yet in operation owing to frequencies not yet having been allotted. Calls to be limited to personal, family and non-transactional matters.

Telephone service between Denmark and Finland limited to personal and non-transactional calls.

13. Public Utilities.

Consumption of Electricity and the continuation of a very limited scale.

FINANCIAL SECTION

1. Financial Administration

(a) Blocklisting and Freezing of Enemy and Collaborator Assets.

Under the Danish law which authorized the blocking and freezing of enemy and collaborator bank accounts, such accounts are being frozen throughout Denmark, and lists of frozen accounts published in the official Gazette Daily. It is notable to us, however, that some of the more important collaborator firms have not yet been included. Meanwhile, we have pointed out to the Danish Government that they still require a law directing the acquisition of enemy interests in Danish companies, and such a law appears to be in process of enactment.

(b) Recovery of Danish currency from Germany.

Krazer currency continues to be collected from Germans in Denmark, and the total recovery of Krazer currency now amounts to about 30 billion.

(c) Transactional Demands/Requests.

No reply having been received from UNRIF regarding authority to lift the restrictions on transactional communications, we have requested of UNRIF immediate authority to permit transactional communications between Danish firms approved by the Danish Government and Swedish firms not on the British statutory or United States prohibited list.

2. Property Control

(a) British/U.S. Property Interests.

Information has now been obtained covering the majority of British/U.S. properties on which information was

0 5 0 2

- 11 -

requested. This information has been forwarded through channels to SHAEF.

(N) German Merchant Shipping.

We continue to unload German cargo ships into custody of Chief Property Control Officer, and dispose of the cargoes in the same manner as any other enemy war material.

(O) Supply of German Troops, and other detained German Personnel.

Financial and property problems connected with this subject are cleared, in common with other financial matters, at two weekly conferences: 1000 hrs each Tuesday at Aarhus, and 1000 hrs each Friday at Bagaarhus, Copenhagen.

(d) Disposal of captured Enemy War Material.

The progress of turnover of enemy war material to the Danish Government on quantitative receipt is proceeding at accelerated pace, although a considerable and thus far increasing demand is being met from the military for enemy such supplies. The system of operation and co-operation with the Danish authorities is now well established and functioning smoothly.

(e) Custody and Inventory of Enemy War Material.

The custody of enemy war material may now be regarded as substantially complete. Inventories are well under way as although, due to the vast dispersal and large quantity of materials left in Denmark by the Germans, it is impossible at this time to estimate the percentage of completion of the task.

(f) Liaison with Danish Authorities, etc., para 11.

The regular weekly meetings reported in the last fortnightly report are continued save that the Saturday meeting at the Foreign Ministry has been discontinued, since the actual work of turn over is handled through a special Danish organization, the Supply Directorate, with whose officials meetings are held much more frequently to work out co-operation and detail of turnover of supplies.

3. Accounting.

(a) Work proceeds on recording of foreign currencies and enquiries incidental thereto.

(b) No expenditure has been incurred out of Civil AF Airs funds.

(c) One quantitative receipt has been received in the fortnightly period making a total of six receipts received to date.

4. Currency

(a) An officer of the Currency Section escorted a consignment of regular Kroner 250,000 to the War Office, London, in accordance with instructions received from SHAEF. This currency was handed over to London District Paymaster on orders of War Office.

(b) Whilst in London this officer took the opportunity of clearing up a number of outstanding points with PS at War Office, especially those relating to the issues of currency made in U.K. after departure of Currency Section, and the ultimate disposal of reserve stocks of Allied Military Kroner held in U.K.

7 4 7 2  
0 5 0 3



- 17 -

(e) A complete audit of Currency Section books, vouchers and stores of Allied Military Order has been carried out by Chief Accountant, ERMAF Mission (Denmark).

#### HEALTH SERVICE

During the last half of June there has been a marked increase in the number of cases of typhoid fever among German displaced persons. The peak was reached during the week ending June 26, when 478 cases were reported. Since that date there has been a decrease in the weekly incidence which may be expected to continue. Precaution against typhoid fever has been completed for the whole displaced persons population, numbering approximately 220,000. Special hospitals have been established for the segregation and medical care of active cases. These cases will be kept in hospital until bacteriological examinations are negative.

Since the Chief of the German Red Cross together with several of his assistants were taken into custody as Nazi sympathizers, the German doctors formerly serving with the German Red Cross have been organized under Danish authority. The organization has been set up to divide the hospital care of German displaced persons into two categories. Hospital wards attached to the larger displaced persons centres will be staffed by German civilian doctors, who will serve under the authority of local Danish health officers. The hospital care for displaced persons in the smaller centres will be provided by hospital wards established in proximity to Danish hospitals wherever needed. These hospital wards will be staffed by Danish doctors, and served by the Danish hospital to which they are attached.

Additional shipments of food from the Danish Red Cross to Belgium, Bulgaria and Greece have been approved and authorized.

Colonel WOOD, U.S. Army Corps, and Colonel SCHWELB, U.S. Public Health Service, Supreme Headquarters, AF, visited Copenhagen to investigate the nutritional status in Denmark.

An additional 29 cases of typhoid fever were reported to Supreme Headquarters, AF, 6-5 Division, Public Health Branch, on 27 June 45, making a total of 93 cases since 1 May 45.

#### REFUGEE AND DISPLACED PERSONS SERVICE

Registration of German Displaced Persons is continuing. It is estimated that 40,000 have now been registered.

60 Norwegians have been repatriated to OSLO by air.

560 French Displaced Persons have come from SWEDEN to DENMARK and have been repatriated to FRANCE by air. Most of them were former concentration camp prisoners who had been taken from GERMANY to SWEDEN by the Danish Red Cross. 50 additional French Displaced Persons have been repatriated from DENMARK to FRANCE by air. 350 Belgian Displaced Persons have also come from SWEDEN and been repatriated to BRUSSELS by air.

6649 Russian Displaced Persons have been uncovered in DENMARK. Arrangements had been completed to repatriate them to RUSSIA, through GERMANY, when word was received from 21 Army Group that they would have to be held up until further notice, due to a bottleneck in the Russian receiving area.

A visit was received from Captain HILS, Chief Czechoslovakian Liaison Officer of 21 Army Group.

The Danish Ministry of the Interior's engineers are supervising the taking down of section huts in various parts of JUTLAND pending reconstruction on new sites, particularly airfields, for the use of Displaced Persons.

0 5 0 4



- 21 -

APPENDIX "F"

SECRETSUPREME HEADQUARTERS  
AFM MISSION (DENMARK)Progress Report No. 19  
24 June 45 - 8 July 45  
PR/PT DivisionPUBLIC RELATIONS SECTION

(a) A torchlight relay race from Copenhagen to Frederiksbund was held by Dansk Ungdoms Samvirke on 23 June 45 in celebration of the Mid-summer Festival. The torch was jointly lit at Dagmarhus by Lt Col Bevan, MC (Br) and Lt Col Markham (US).

(b) PRO returned from conducting party of 12 to Bornholm. They were the guests of the Amtmand and were received in the Hq of the Division General.

(c) Danish Press Correspondent and 1 Danish Radio reporter have been sent in own transport to 21 AG to join PR convoy to Berlin.

(d) Lt Com Stephens spoke, as principal speaker at meeting of Danish Society of Dentists, 27 June 45.

(e) Brigadier Crowe held his Press Conference on 27 June 45 at 1030 hours, it was very well received.

(f) Colonel Gibbs of PRD SHAEP visited on 28 June 45 to investigate PR facilities in Denmark.

(g) A party has left for Jutland to go to the Danish-American meeting at Rebild on occasion of the celebration of Fourth July.

(h) Major John W. Streeter, PRO, leaves the Mission for UK on 7 July. His place has been taken by Major Basil Gray (KOSS).

PSYCHOLOGICAL WARFARE SECTION1. Press

(a) Work in this department has increased materially during the past 2 weeks, apparently as the result of a greater awareness on the part of SHAEP department and Section Chiefs of the importance of news to Danish Newspapers and other news spreading agencies.

(b) During this period a total of 50 releases was issued, almost double the number sent out by the Section during the preceding fortnight. Of course the amount of background material sent out accounted for some of the increase in volume of work, and this was due to certain events of world interest. Releases from the British Occupation zone also have increased, resulting in some increase in the number of releases.

(c) During the past 2 weeks the bi-weekly report sent to the Danish Foreign Office has shown marked improvement because more and more pertinent figures are being sent to the Section by various G-5 Section Chiefs. The Royal Navy also has been supplying us with interesting figures. It may be interesting to note that our releases to the Foreign Minister are being reprinted almost word for word by the local press.

(d) The RAF Air Show and Exhibition required much of this Section's time during the period. It was necessary to handle all the publicity, as well as necessitating the exclusive use of one man on public relations work in connection with the 2 shows.

(e) Perhaps the most important work of the Section, although intangible, was the preparation of the San Francisco summary and interim agreement and circulation of the 2 documents to the press. The full Charter text is now in process of preparation.

0505

SECRET

- 22 -

2. Publications

(a) Since the start of operations 25 publications with a total of 500,000 copies have been received and put on sale at bookstalls and kiosks in Denmark.

(b) Representatives of the Danish book-trade are still awaiting transportation in order to proceed to London to arrange for the import of American and British books.

(c) As the limited number of posters received has not permitted a very widespread distribution, authorization has been received to print some of these locally in postcard form.

(d) On 30 June Mr. Murray left Publications Section and returned to London.

(e) JORDEN RUNDT I BILLEDER. Weekly pictorial news bulletin of this name is being produced locally. Distribution is as follows:

Danish Armed Forces  
Danish Resistance Movement  
Joint Cooperative Chain Stores  
Post Offices  
Railway Stations  
Signboards  
DANSKE BOGHANDLERES KOMMISSIONARSTAT

(f) Authority has been received to distribute the US Insignia Booklet free of charge.

(g) Displays. A large corner window at the Department Store ILLUM is now showing a USAF display. Series of other displays have been planned.

3. Exhibition

(a) Some confusion has developed regarding the photographic material to be displayed in the Copenhagen Exhibition.

After Mr. Larsen's visit to Belgium on 14 - 16 June to view the current exhibition in Antwerp and for conversations with FWD architect, Mr. O'Clara, a series of requests for photographs were sent to FWD Rear between 21 - 23 June. These photographs were to supplement the so-called documentary series of pictures of the war. The documentary series were supposed to arrive in Copenhagen via Stockholm. Latest information is that they were to be carried to Copenhagen on 30 June. However, they have not yet arrived.

(b) Major Bremer will, during his visit in London, discuss the matter of the above additional requests with FWD Rear and MOI and OWI.

(c) Requests have been made to Q(AE) 1 HQ 21 AG for British Army Stores. Small items have been requested for delivery by air as soon as possible. Larger vehicles and weapons to come in by road, arriving in Copenhagen not later than 20 July 49.

(d) We hope to obtain American Army equipment from Germany. Col Trumble has offered to contact the proper source for this.

(e) Air Component has been invited to participate in the Exhibition with one British and one American aircraft besides smaller items.

(f) Naval Component has made available one-man submarine and a "Hummel-Torpedo", captured in Denmark. US Navy photographs, handed over to us, are mounted and ready for the exhibition. Supplementary Royal Navy photographs have been requested from MOI.

(g) Carpentry work is progressing on the exhibition premises. Display work is also under way.

(h) The Resistance Battalion stationed at Vesterport, has on several occasions made difficulties for the architect and carpenters working on the exhibition. While they are not actually obstructing progress it is hoped that our full and unobstructed access to and use of the localities for the exhibition will be obtained as soon as possible.

0 5 0 6

- 23 -

SECRET

4. Films

(a) Arranged for second booking at the Scala Cinema of the Frank Capra documentary DAVIDE AND CONQUER, also for the Dagmar Cinema of PRELUDE TO WAR.

(b) A private screening of the production THE WAY AHEAD has been shown at the Palladium Cinema for Her Majesty the Queen of Denmark.

(c) The Danish Minister to Russia saw a private screening of the production BATTLE OF RUSSIA and gave his impressions to the press.

(d) The Dagmar Cinema opened with MEMPHIS BELLE and I MARRIED A WITCH; both features were given good reports in the newspapers.

(e) Arrangements were made for a continuous transfer of Norwegian films to Oslo.

(f) We had a special screening of the production THE WAY AHEAD for General Dewing.

(g) We received from the laboratory in London the German atrocity films consisting of a tape negative and a sound track. The positive printing on this subject will be done here in Copenhagen. This subject is scheduled to play at the first run cinemas in Copenhagen starting Monday 9 July 45.

0 5 0 7

- 24 -

ANNEX 'G'.

SUPREME HEADQUARTERS  
AEP MISSION (BERGARK)

Progress Report No. 19  
24 June 45 - 7 July 45  
Air Component  
-----

R.A.F. EXHIBITION.

1. The Royal Air Force Static Exhibition at the Magasin du Nord was opened by His Royal Highness Prince Axel and Air Marshal Sir Arthur Coningham on Saturday, 23rd June, 1945. The Exhibition, which has attracted a great deal of interest and publicity, has been heavily attended by large crowds from the first day of its being open to the general public, Monday, 25th June. A conservative estimate shows 156,000 have attended the Exhibition since its opening, to date. The exhibit which has attracted most attention is the Link Trainer; the Spitfire Fighter also evoked considerable interest.

AIR DISPLAY AT KASTRUP.

2. The Air Display at Kastrup, which had previously been postponed until Sunday, July 1st, was again officially postponed on the evening of July 1st by order from Headquarters 81 Group, due to bad weather conditions obtaining in Norway. As, however, vast crowds had already collected at the Airport by the time the announcement of the cancellation was made, and as permission was later obtained for limited flying according to local weather conditions, it was decided to stage a small display with what aircraft was available. The Queen of Denmark, identified her destination to attend this unofficial display and arrived at the airfield at 14.50 hours accompanied by Prince Axel, Princess Margrethe and other members of the Royal House. An R.A.F. Regiment Guard of Honour was drawn up and the R.A.F. Band played the national honours for the occasion. The meeting proved a success and it is estimated that well over 200,000 people saw the display from the airfield and its immediate vicinity.

REPRODUCTION OF GERMAN AIRCRAFT PERSONNEL.

3. The reproduction of German Luftwaffe personnel continues in a satisfactory manner, although "borrowing" of certain grades of personnel, and the decision to evacuate by units has slowed down the rate of evacuation. Up to July 5th, a total of 3,841 Luftwaffe personnel had been evacuated from Norway.

AIR TRANSPORT.

4. The question of providing refuelling facilities at Kastrup for the Danish Air Transport Company's Catalina has now been thoroughly examined, and the Danish Ministry for Foreign Affairs has been informed that the Catalina can be refuelled provided 72 hours warning of the arrival of the aircraft is given. The Ministry has also been asked to supply, for purposes of security control, an advance list of passengers to be carried on each of the three journeys.

5. Air Transport arrangements for service personnel proceeding on leave to U.S. from Bergark were discussed on 5th July, 1945, with Wing Commander Andrews of 81 Group Headquarters, and an interim allocation of five seats per day to Bergark Group was decided for such purposes.

6. The American A.T.S. daily service from Paris-Brussels-Brno-Copenhagen-Stockholm was opened on 25th June, 1945. This will be extended to include Oslo in the near future.

MOVE TO MERRY OF A.T.S.

7. Arrangements were completed during the period under review for the movement to Merry of 5/Lt. Rugeoth and the 2nd T.A.F. A.T.S. team which had been based on Vaerfoss. The necessary movement order was issued by 2nd T.A.F. M.O. 4  
0 5 0 8

- 25 -

DANISH AIRFIELDS.

8. Agreement was obtained for the use of Aalborg/Århus for the use of civil air services by the Danish authorities.
9. Arrangements are being made for a small Danish Mission to inspect the existing airfields with a view to determining which will be earmarked by Danish authorities for future use.
10. Preliminary arrangements are in hand to make adequate provision for the guarding of airfields by Danish personnel on the withdrawal of German personnel.

REPATRIATION OF INVALED DANISH DISPLACED PERSON.

11. Arrangements were made for a Danish Ambulance Plane to proceed to Paris to return with a Danish Displaced Person lying seriously ill at Le Mans.

VISITS.

12. Air Marshal Sir Richard Peck, Air Vice Marshals Sir Victor Tait, E.S. Addison, R.C. Hurlston and H. Broadhurst paid short visits to Copenhagen during the period under review.
13. Group Captain Dowling and the WAAF Band arrived in Copenhagen on July 1st, in time for the band to play at the R.A.F. Display at Kastrup.
14. Group Captain Burgess arrived on June 29th to discuss preliminary arrangements for a Missing Personnel Research team to be set up in Denmark.
15. Squadron Leader Fowler of 2nd TAF visited Copenhagen and a useful discussion took place on problems outstanding in connection with common user items of enemy war material.

PUBLIC RELATIONS.

16. Arrangements were made for 60 students of the Pyram Technological Institute to visit Kastrup airfield on Monday, 9th July, 1945.
17. The Deputy Head of the Air Component, Colonel Robert F. Harris, attended the Danish/American celebration of July 4th, at Aarhuus.

UNVEILING OF MONUMENT.

18. Arrangements were completed for unveiling of memorial at Mønster (Grigstov) by Danish 2nd regiment honourary to two Douglas aircraft killed in September, 1944.

AIR INTELLIGENCE.

19. SHAF Mission Norway was visited and discussions took place there on the interchange of air intelligence for Scandinavia.
20. The German Liaison Staff was alerted to furnish certain air technical intelligence required by the A.C. of S. U.S.A.A.F.

PERSONNEL.

21. Wing Commander H.M. Barr, A.F.C., and Major C.J. Yodman reported for duty as British/American A-4, respectively, during the period under review.  
and

0509

- 25 -

SUPREME HEADQUARTERS      APPENDIX H.  
 ACF MISSION (DENMARK)

Progress Report No. 19  
 23rd June-7th July  
 Naval Component.

GENERAL:

1. The Allied Naval Commander-in Chief visited Copenhagen 26-27 June.
2. German Cruiser LIPZIG was finally sailed from Aabenraa to Wilhelmshaven on the 13th June.
3. Coastal Force Maintenance Unit No. 2 in Taastrup was sailed from Naeskov to Flensburg on the 13th June to join the Kiel Command.

There remain in Danish waters:  
 3 British Minesweeping Flotillas  
 189th Aux. M/S Group  
 2 Motor Launch Flotillas.  
 3 Trainers.

DISARMAMENT:

1. Sailing of German Naval Vessels to Germany continues, and a further 80 have been sailed in addition to those mentioned in the last report.
2. A detailed programme has been prepared for the disposal of all remaining surplus German vessels including civilians, fishing craft of which there are large numbers.
3. Fort Tordis was handed over to the Danish Naval Authorities on 7th July. In this Fort are stored the most part of the ammunition outfit for the German destroyers RAIBER, UGEL and HANSEBO. These have to be retained, and the Danish authorities are holding them for safe custody.
4. Details of the disarmament situation in the British zone in Germany (EXFOR Mainz Signal VII in 1945) removal of surplus personnel has been considered, and some shore arrangements can be made well in advance.
5. Loading of explosives to be shipped to Kiel for 21st Army Group is progressing and 2 S. S. ships with 200 tons is due to complete 13th July.
6. Arrangements have now been completed for the shipping of surplus naval ammunition in the case of a large volume from agreed with the Danish Authority at the end of July. Loading is due to commence on the 14th commencing 9th July. German ships and working parties are to be used. Quantity of surplus naval ammunition amounts to about 2,000 tons, but the organization should be available to deal with certain quantities of surplus ammunition for the Army and R.A.F. in due course.

0510



- 17 -

MINESWEEPING.

1. Steady progress has been made during the period under review, and considerable progress towards the completion of the first part of the clearance of the main channels and ways to the Sava, Sound, and Great Belt has resulted.
2. Channels previously swept by German minesweeping forces are being checked, and it is expected that it will be possible to commence widening the channels within the next few days. An increase in the mines swept is to be expected as soon as this widening starts.
3. It is unlikely that any further British minesweepers will be allocated to Danish waters; the 159th Aux. M/S Group has been ordered to return to U.K. and will be leaving during the night.
4. 100 German minesweeping vessels are now in operation. The German vessels are extremely uneconomical and insurance is very small compared with the British. The operative state is dependent on the work of various civilian repair yards, and up to the moment it is disappointing.
5. The Danish M/S Forces have not yet come into being and progress is somewhat slow. It is realized, however, that in addition to making good the defects and fitting out with German gear the training of the personnel presents many difficulties and cannot be accelerated as is desirable.

SUPPLY.

1. Victualling of German M/S personnel. Arrangements have now been completed for the Danish authorities to take over all stores of German food in Denmark, and for the feeding of German Naval personnel employed in Danish Waters.
2. Very large stores of flour and sugar brought to Copenhagen from East Baltic Ports before the capitulation were dumped in the food stores in the Freshwater, and these will be used not only for victualling Naval personnel but also for other German workers. The administration is in the hands of the Civil Air Defence, who has undertaken the rationing of foodstuffs in accordance with local scales.
3. At a meeting in Flensburg on 3rd July proposals were discussed by A.N.C.P.X. (O.K.M.) regarding the pay victualling of German minesweeping personnel, and there will be brought up at a meeting on Monday, the 9th July at SHARP HEADQUARTERS.
4. The muster of German Naval stores and clothing is proceeding according to plan.

0511





0 5 1 2



0 5 1 3



0514



0 5 1 5

**OUTGOING**

~~SECRET~~  
EX. FILE IN  
CLASSIFIED FILES

|              |          |           |
|--------------|----------|-----------|
| DECLASSIFIED | 44/07/15 | 519.312-1 |
| EXEMPT TO    | 44/08/31 |           |

**15 JULY - 31 AUGUST**

**JK 1257- JK 2432**

**T453-T294**

EX. FILE IN  
CLASSIFIED FILES

*ESC  
USSTAF, Europe  
Comm Sec  
Refile in Box AF 1483*

*5-997*

DECLASSIFIED  
EO 11652

1029156

~~SECRET~~  
0516

21 AUG JK-2047 SUPPLY CONVOY DUE MURMANSK-CASERTA <sup>MEETING</sup> CG JBPD  
 22 AUG T-294 FRANTIC-TARGETS DESIRED BY SOVIETS. WPS  
 23 AUG JK 2063 FRANTIC- SOV. CANCEL FRANTIC X T-294 ↑ CG JSHL  
 23 AUG JK 2063 FRANTIC- SUGGEST OBTAIN MESSAGE RECONSTRUCTION CG USAFME  
 23 AUG JK 2065 RELAY TO MOSCOW OF JK 2063 AND JK 2063 CG JMR  
 " JK 2069 FRANTIC 7- FUTURE RECOMMENDATION CG JBPD JSCA  
 25 AUGUST  
 26 AUGUST  
 27 AUGUST  
 JK 2356 SUPPLIES TO BE STALLED-EVACUATION <sup>PREPARATION FOR</sup> CG JSHL  
 JK 2357 RELAY OF MSG (2912) JW 931E CG JMR  
 JK 2358 PROPOSAL FOR NEW BOMB LINE-SUBMITTED TO <sup>PERMINDU</sup> CG JSHL  
 JK 2359 PROPOSAL TO ATTACK AIRFIELDS IN ROMANIA TO <sup>PERMINDU</sup> CG JSHL  
 28 AUG JK 2360 ROMANIAN AIRFIELDS CAPTURED-NEW BOMB LINE CG JMR  
 28 AUGUST  
 JK 2361 FERRY CRAWLS FOR B-17S CG JSHL  
 29 AUGUST  
 JK 2384 SHIPMENT OF SUPPLY RECOMMENDED TO BE <sup>HELD UP</sup> CG JBPD  
 JK 2391 MARKING OF MATERIAL AT TEHRAN: <sup>TO R 0667</sup> ADM JFZA  
 JK 2396 NO INFORMATION FROM MOSCOW OF NEW BOMB LINE CG JSHL  
 30 AUGUST 1944  
 JK 2402 MOSCOW OBTAIN RTT-DIRECT EQUIPMENT CG JMR  
 31 AUGUST  
 JK 2432 BOMB LINE-HELP TO GET SOV. PROPOSAL CG  
 1 SEPTEMBER  
 2 SEPTEMBER  
 3 SEPTEMBER

0517



| Date      | E.C. Nr | SUBJECT                                     | From | To  |
|-----------|---------|---|------|-----|
| 14 AUG    |         |   |      |     |
| 15 August | T-197   | FRANTIC 6 - REPAIRS                         | CG   | JBR |
|           | T-197   | FRANTIC 6 - REPAIRS                         | CG   | JBR |
|           | T-202   | B-24 - STATUS                               | CG   | JBR |
|           | T-201   | FRANTIC 6 - Flight Plans                    | CG   | JBR |
| 16 August | NK-113  | FRANTIC 6 - Disapproval of Plans            | CG   | JBR |
|           | T-194   | East Com - Plans - Supplies + Missions      | CG   | JBR |
|           | T-216   | HIGHBALL - 7 - CLEARANCE                    | CG   | JBR |
|           | T-196   | Mission - 16 - PFC to hold all shipments    | CG   | JBR |
|           | T-197   | Mission - 16 - PFC to hold all shipments    | CG   | JBR |
| 17 August | T-224   | FRANTIC 6 - PARTS                           | CG   | JBR |
|           | T-225   | FRANTIC 6 - PARTS                           | CG   | JBR |
| 18 August | T-237   | HIGHBALL - CRANE, FRANTIC 6                 | CG   | JBR |
|           | T-238   | HIGHBALL - DESIRED COVERAGE DAILY           | CG   | JBR |
| 19 August | T-243   | FRANTIC Six - POSTPONED 20 AUG              | CG   | JBR |
| 19 AUG    | T-244   | FRANTIC Six - Query                         | CG   | JBR |
| "         | T-256   | FRANTIC Six - PENDING OF CLEARANCE          | CG   | JBR |
| "         | T-257   | FRANTIC Six - SCHEDULED FOR 20 AUG          | CG   | JBR |
| "         | T-259   | FRANTIC Six - SCHEDULED FOR 20 AUG          | CG   | JBR |
| "         | T-260   | FRANTIC Six - SCHEDULED FOR 20 AUG          | CG   | JBR |
| "         | T-272   | HIGHBALL - 7 - CLEARANCE                    | CG   | JBR |
| 20 AUG    | T-275   | FRANTIC 6 - MEETING ORDERS                  | CG   | JBR |
| 20 AUG    | T-276   | FRANTIC 6 - Supplies from ITALY             | CG   | JBR |
| 21 AUG    | JK-2043 | REASON FOR FRANTIC 6 DISAPPROVAL            | CG   | JBR |
| 21 AUG    | JK-2044 | OPINION ON SITUATION IN REGARDS TO MISSIONS | CG   | JBR |





LOCAL DELIVERY LIST

DELIVERED TO ~~XXXXXXXXXX~~

DATE Beginning 7/14

OUT ~~XXXXXXXXXX~~

| M. C. # | UNIT      | SIGNATURE       | TIME DEL'D. |
|---------|-----------|-----------------|-------------|
| 1812    | OWS       | A. A. [unclear] | 1722        |
| 7/16    | ASS       | N. A.           | 1705        |
| 1816    | OPS       | [unclear]       | 1912        |
| 1817    | OPS       | [unclear]       | 1845        |
| 7/17    | 18194     | ORD             | 1052        |
| 1819    | OPS       | [unclear]       | 1142        |
| T-462   | OPS       | [unclear]       | 1314        |
|         | OPS       | [unclear]       | 1324        |
|         |           |                 |             |
| T-477   | OPS       | [unclear]       | 1552        |
| T-478   | OPS       | [unclear]       | 1915        |
|         |           | T. Shaw         | 1927        |
|         |           | [unclear]       | 1312        |
|         |           | [unclear]       | 1335        |
| T-499   | OPS       | [unclear]       | 1730        |
| T-500   | CG        | [unclear]       | 1152        |
| T-495   | OPS       | [unclear]       | 1152        |
| 181363  | GEN WALSH | [unclear]       | 1555        |
| 181365  | GEN WALSH | [unclear]       | 1536        |
| T-498   | OPS       | [unclear]       | 1730        |
| T-499   | OPS       | [unclear]       | 1730        |
| T-500   | OPS       | [unclear]       | 1730        |
| T-502   | OPS       | [unclear]       | 1836        |

0520

↑ LOCAL DELIVERY LIST ↑

DELIVERED TO \_\_\_\_\_

DATE 7/22

~~IN~~ - OUT

| NO.            | OFFICERS               | SIGNATURE | TIME DEL'D. |
|----------------|------------------------|-----------|-------------|
|                | ORIGIN.                |           |             |
|                | COAAF                  |           |             |
| T-517          | 7/23<br>MAYES          |           | 1755Z       |
| T-522          | TURNING                | H. Egan   | 2234Z       |
| T-523          | Exher for<br>T. Waring | H. Egan   | 1115        |
|                |                        | M. Egan   | 1130        |
|                | Exher for<br>T. Waring |           |             |
| T-529          | PM<br>T. Waring        | H. Egan   | 0930Z       |
| T-531          |                        |           | 1130Z       |
| T-536          | OPS                    |           | 1930Z       |
| 7/24           |                        |           |             |
| T-540          | OPS                    |           | 0840        |
| T-546          | COL<br>SULLIVAN        | H. Egan   | 1428Z       |
|                |                        |           | 2135Z       |
| 7/25           |                        |           |             |
| T-557          | OPS                    |           | 0955Z       |
| T-559          | OPS                    |           | 1730Z       |
| T-561          | OPS                    |           | 0955Z       |
| T-568          | OPS                    |           | 1730Z       |
| T-572          | OPS                    |           | 2130Z       |
| T-576          | OPS                    |           | 0137Z       |
| T-578          | OPS                    | H. Egan   | 0953Z       |
| T-579          | OPS                    | H. Egan   | 1405Z       |
| 7/27           |                        |           |             |
| J. W. Sullivan | CS                     | H. Egan   | 0840Z       |

0 5 2 1

↑ LOCAL DELIVERY LIST ↑

DELIVERED TO \_\_\_\_\_

DATE 7/27

**OUT**

| M. C. R. NR. | WRITERS NR. | SIGNATURE   | TIME DEL'D |
|--------------|-------------|-------------|------------|
| T-589        | OPS         |             |            |
| T-596        | DPS         | W. J. Moran | 1607Z      |
| JK1498       | OPS         | W. J. Moran | 1607Z      |
| 7/28         |             |             |            |
| T-604        | DPS         | W. J. Moran | 1607Z      |
| T-603        | OPS         | W. J. Moran | 1607Z      |
| T-603        | OPS         | W. J. Moran | 1651Z      |
| T-608        | OPS         | W. J. Moran | 1712Z      |
| 7/29         |             |             |            |
| T-610        | OPS         | W. J. Moran | 1712Z      |
| JK1536       | 1st         | W. J. Moran | 1607Z      |
| JK1538       | 1st         | W. J. Moran | 1607Z      |
| T-626        | OPS         | W. J. Moran | 1915Z      |
| T-637        | OPS         | W. J. Moran | 0909Z      |
| JK1561       | 1st         | W. J. Moran | 1130Z      |
| T-643        | OP          | W. J. Moran | 1130Z      |
| JK1562       | OP          | W. J. Moran | 1130Z      |
| T-648        | 1st         | W. J. Moran | 1130Z      |
| T-649        | OPS         | W. J. Moran | 1130Z      |
| T-650        | OPS         | W. J. Moran | 1130Z      |
| T-651        | OPS         | W. J. Moran | 1130Z      |

0 5 2 2

LOCAL DELIVERY LIST

DELIVERED TO \_\_\_\_\_

DATE 7/31

OUT

| M. C. R. NR.  | WRITER'S NR. | SIGNATURE | TIME DEL. |
|---------------|--------------|-----------|-----------|
|               | 31           | JULY 44   |           |
| T-63          | OPS          | Palton    | 1400      |
| T-64          | OPS          | Palton    | 1435      |
| T-65          | ADM          | Palton    | 1402      |
| 2 AUGUST 1944 |              |           |           |
| T-1           | OPS          | Palton    | 1105      |
| T-2           | OPS          | Palton    | 0900      |
| T-3           | OPS          | Palton    | 1102      |
| T-4           | OPS          | Palton    | 1510      |
| T-5           | OPS          | Palton    | 1510      |
| T-6           | OPS          | Palton    | 1540      |
| T-7           | OPS          | Palton    | 0840      |
| T-8           | OPS          | Palton    | 1102      |
| T-9           | OPS          | Palton    | 1142      |
| T-10          | OPS          | Palton    | 1142      |
| T-11          | OPS          | Palton    | 1142      |
| T-12          | OPS          | Palton    | 1142      |
| T-13          | OPS          | Palton    | 1142      |
| T-14          | OPS          | Palton    | 1142      |
| T-15          | OPS          | Palton    | 1142      |
| T-16          | OPS          | Palton    | 1142      |
| T-17          | OPS          | Palton    | 1142      |
| T-18          | OPS          | Palton    | 1142      |
| T-19          | OPS          | Palton    | 1142      |
| T-20          | OPS          | Palton    | 1142      |
| T-21          | OPS          | Palton    | 1142      |
| T-22          | OPS          | Palton    | 1142      |
| T-23          | OPS          | Palton    | 1142      |
| T-24          | OPS          | Palton    | 1142      |
| T-25          | OPS          | Palton    | 1142      |
| T-26          | OPS          | Palton    | 1142      |
| T-27          | OPS          | Palton    | 1142      |
| T-28          | OPS          | Palton    | 1142      |
| T-29          | OPS          | Palton    | 1142      |
| T-30          | OPS          | Palton    | 1142      |
| T-31          | OPS          | Palton    | 1142      |
| T-32          | OPS          | Palton    | 1142      |
| T-33          | OPS          | Palton    | 1142      |
| T-34          | OPS          | Palton    | 1142      |
| T-35          | OPS          | Palton    | 1142      |
| T-36          | OPS          | Palton    | 1142      |
| T-37          | OPS          | Palton    | 1142      |
| T-38          | OPS          | Palton    | 1142      |
| T-39          | OPS          | Palton    | 1142      |
| T-40          | OPS          | Palton    | 1142      |
| T-41          | OPS          | Palton    | 1142      |
| 4-1668        | INTELL       | Palton    | 1142      |

4 AUGUST 1944

Palton

LOCAL DELIVERY LIST

DELIVERED TO \_\_\_\_\_

DATE 8/5

ONT

| M. C. R. NR. | WRITERS NR. | SIGNATURE | TIME DEL'D. |
|--------------|-------------|-----------|-------------|
| T-46         | CPS.        | W. Moran  | 0720Z       |
| T-47         | OPS.        | W. Moran  | 0835Z       |
| T-50         | CPS.        | W. Moran  | 0855Z       |
| T-53         | OPS.        | W. Moran  | 0940Z       |
| T-54         | OPS.        | W. Moran  | 1300Z       |
| T-55         | OPS.        | W. Moran  | 1359Z       |
| T-57         | OPS.        | Whitman   | 1515Z       |
| S/L          |             |           |             |
| T-62         | OPS.        | W. Moran  | 0930Z       |
| YK173        | CG          | W. Moran  | 1525Z       |
| YK174        | CG          | W. Moran  | 1525Z       |
| YK175        | CG          | W. Moran  | 1525Z       |
| T-81         | OPS.        | W. Moran  | 1701Z       |
| YK172        | CG          | W. Moran  |             |
| T-82         | OPS.        | W. Moran  |             |
| S/T          |             |           |             |
| YK176        | CG          | W. Moran  | 1714Z       |
| T-77         | OPS.        | W. Moran  | 0905Z       |
| YK173        | CG          | W. Moran  | 0930Z       |
| T-92         | OPS.        | W. Moran  | 1215Z       |
| T-78         | OPS.        | W. Moran  | 1318Z       |
| T-76         | OPS.        | W. Moran  | 1605Z       |
| RELAY        | C/S         | W. Moran  | 1645Z       |

0 4 1 5  
0 5 2 4







LOCAL DELIVERY LIST

DELIVERED TO \_\_\_\_\_

DATE 13 AUGUST

OUT

| W. C. R. NR | WRITERS NR | SIGNATURE | TIME DEL'D. |
|-------------|------------|-----------|-------------|
| T173        | OPS        | Wood      | 1212        |
|             |            | A. Moran  | 1212        |
| 1448 T-180  | OPS        | A. Moran  | 1331        |
| T181        | OPS        | A. Moran  | 1823        |
| T182        | INTEL      | A. Moran  | 115         |
| T183        | OPS        | A. Moran  | 115         |
| T184        | OPS        | A. Moran  | 115         |
| T190        | OPS        | A. Moran  | 115         |
| 15 August   |            |           |             |
| T191        | CG         | A. Moran  | 115         |
| T201        | OPS        | A. Moran  | 1932        |
| T202        | OPS        | A. Moran  | 1932        |
| 16 August   |            |           |             |
| T203        | CG         | A. Moran  | 1932        |
| T204        | CG         | A. Moran  | 1932        |
| T216        | OPS        | A. Moran  | 1932        |
| T217        | CG         | A. Moran  | 1932        |
| T218        | CG         | A. Moran  | 1932        |
| T219        | CG         | A. Moran  | 1932        |
| 17 AUGUST   |            |           |             |
| T220        | OPS        | A. Moran  | 1712        |
| T-225       | OPS        | A. Moran  | 1712        |

0 4 1 5  
0 5 2 6

LOCAL DELIVERY LIST

DELIVERED TO \_\_\_\_\_

DATE 17 AUGUST 1944

*OUT*

| M. C. R. NR.     | WRITERS NR. | SIGNATURE | TIME DEL'D. |
|------------------|-------------|-----------|-------------|
| <b>18 August</b> |             |           |             |
| T-237            | OPS         | Wood      | 1510        |
| T-238            | OPS         | Wood      | 1500        |
| T-239            | OPS         | Wood      | 1500        |
| <b>19 AUGUST</b> |             |           |             |
| T-244            | OPS         | Z. Brown  | 1335        |
| T-245            | OPS         | Wood      | 1300        |
| T-246            | OPS         | Wood      | 1300        |
| T-247            | OPS         | Wood      | 1300        |
| T-248            | OPS         | Wood      | 1300        |
| <b>20 AUGUST</b> |             |           |             |
| T-249            | OPS         | Wood      | 1600        |
| T-250            | OPS         | Wood      | 1745        |
| T-251            | OPS         | Wood      | 1800        |
| <b>21 August</b> |             |           |             |
| JK203            | CG          | Bob       | 812         |
| JK204            | CG          | Bob       | 1500        |
| JK205            | CG          |           |             |
| <b>22 AUGUST</b> |             |           |             |
| T-294            | OPS         | Wood      | 1826        |
| <b>23 AUGUST</b> |             |           |             |
| K-206            | CG          | Wood      | 2320        |
| K-207            | CG          | Wood      | 2320        |

0 4 1 0  
0 5 2 7

LOCAL DELIVERY LIST

DELIVERED TO \_\_\_\_\_

CUT " " DATE 23 AUGUST 19

| M. C. R. NR. | WRITER NR. | SIGNATURE | TIME DEL'D. |
|--------------|------------|-----------|-------------|
| JK2065       | CG         | W. H. ... | 1640Z       |
|              | CG         | W. H. ... | 1730Z       |
| 27 AUGUST    |            |           |             |
| JK2356       | CG         | W. H. ... | 1800Z       |
| JK2357       | CG         | W. H. ... | 1814Z       |
| JK2358       | CG         | W. H. ... | 1850Z       |
| JK2359       | CG         | W. H. ... | 1950Z       |
| JK2360       | CG         | W. H. ... | 2110Z       |
| 28 AUGUST    |            |           |             |
| 29 AUGUST    |            |           |             |
| JK2374       | CG         | W. H. ... | 1814Z       |
| JK2391       | ADMS       | W. H. ... | 1350Z       |
| JK2370       | CG         | W. H. ... | 1530Z       |
| 30 AUGUST    |            |           |             |
| JK2402       | CG         | W. H. ... | 1930Z       |
| 31 AUGUST    |            |           |             |
| JK2437       | CG         | W. H. ... | 1405Z       |
| 1 SEPTEMBER  |            |           |             |
| 2 SEPTEMBER  |            |           |             |
| 3 SEPTEMBER  |            |           |             |

0417  
0528

OUT

| DATE | E.C. No. | SUBJECT                                    | ORGANIZATION | ADDRESS |
|------|----------|--|--------------|---------|
| 2/5  | T-47     | FRANTIC 5 - MANDOR BTWEN                   | OPS          | YBPD    |
| 2/5  | T-50     | FRANTIC 5 - MANDOR BTWEN                   | OPS          | YBPD    |
| 2/5  | T-52     | FRANTIC 5 - MECHANICS                      | OPS          | YBPD    |
| 2/5  | T-54     | FRANTIC 5 - ARRIVED                        | OPS          | YBPD    |
| 2/5  | T-55     | FRANTIC 5 - SOVIETS TOLD - ETA - RADIO OPS | OPS          | YBPD    |
| 2/5  | T-57     | HIGHBALL - CLEARANCE REQ. FROM SWIFT OPS   | OPS          | YBPD    |
| 2/5  | T-69     | FRANTIC 4 - PX HISTORY                     | OPS          | YBPD    |
| 2/5  | T-73     | DAILY - TALKS WITH RUSSIANS                | OPS          | YBPD    |
| 2/5  | T-74     | FRONTLINE INFO REACHING                    | OPS          | YBPD    |
| 2/5  | T-75     | ROUNDUP OF DAILY YEC FUTURE                | OPS          | YBPD    |
| 2/5  | T-81     | FRANTIC 5 - PLAN FOR 7 AUGUST              | OPS          | YBPD    |
| 2/5  | T-81     | CHARACTER RUSSIAN ATTITUDE                 | OPS          | YBPD    |
| 2/5  | T-82     | FRANTIC 5 - TARGETS, RETURN TO OPS         | OPS          | YBPD    |

0 5 2 9

| DATE     | J.C. No. | SUBJECT   | ORGANIZATION | ADDRESSEE         |
|----------|----------|---|--------------|-------------------|
| 30 JULY  | JK1562   | MISSION PLANS-RELAY OF 1930                                     | OPS          | DEANE FOR WALSH   |
|          | JK1561   | GAF PARTIES   | INTEL        | SPACEA SPA FOR    |
|          | T646     | GAF A/C DEST.-ENGINE SERIAL NR'S                                | INTEL        | MCQUONALD         |
|          | T650     | SOVIETS REFUSE JASLO ETC AS TARGETS                             | OPS          | EAKER DEANE FOR   |
|          | T651     | RELAY OF ABOVE TO MOSCOW  | OPS          | WALSH             |
| 31 JULY  | T649     | DOLLY PROJECT-SUMMARY OF SITUATION                              | OPS          | SPAATZ            |
|          | T664     | DOLLY PROJECT-CLASSIFY TOP SECRET                               | OPS          | SPAATZ            |
|          | T663     | FRANTIC 4-300TH MECH HELD-NO VISAS FOR 15TH GROUND ECHEL.       | OPS          | EAKER             |
| 1 AUGUST | JK1594   | VISA SETUP CRITICAL-SEND 50 B17 MECHANICS ADM FROM EC TO TEHRAN | OPS          | SPAATZ DEANE FOR  |
| 2 AUGUST | T1       | FRANTIC 4-PLANS   | OPS          | WALSH SPAATZ      |
|          | JK1618   | SANITATION SITUATION AT BASES&DISPERSAL CULLEN                  | OPS          | EAKER DEANE FOR   |
|          | JK1619   | GAF-ACTIVITY INFO RELAY TO MOSCOW                               | INTEL        | WALSH             |
| 3 AUGUST | T11      | FRANTIC 4-REQUEST INFO ON A/C TYPES                             | OPS          | SPAATZ            |
|          | T12      | FRANTIC 4-COMPLIED WITH REQUEST FOR B17 CLEARANCE               | OPS          | EAKER SPAATZ      |
|          | T13      | FRANTIC 4-PERMINOV REQUEST FOR TARGETS                          | OPS          | EAKER SPA, EA     |
|          | T20      | FRANTIC 4 & HIGHBALL CLEARANCE                                  | OPS          | TWI, POLI EA, SPA |
|          | T21      | TARGET INFO-ANSWER TO 2049                                      | INTEL        | DOOLITTLE EA FOR  |
|          | T23      | TARGET MATERIAL REQUEST   | INTEL        | TWINING EA FOR    |
|          | T26      | FRANTIC 4-SOVIETS NOTIFIED                                      | OPS          | TWINING           |
|          | T27      | FRANTIC 5-TARGET REQUEST TO RUSSIANS MADE PRO SHUTTLE           | OPS          | SPAATZ DEANE FOR  |
| 4 AUGUST | T28      | FRANTIC 4-TARGET-DATE-FORECAST                                  | OPS          | WALSH EA FOR      |
|          | T37      | FRANTIC 4-IMPRACTICAL TO ATTACK SAUGUST CULLEN                  | OPS          | TWINING EA FOR    |
|          | T38      | SEND EC PRO PRINTS BY NEXT F-5                                  | INTEL        | TWINING           |
|          | JK1668   | INTEL MESSAGES-ANSWER TO QUERY                                  | INTEL        | DEANE EA FOR      |
|          | T40      | FRANTIC 4-ADDITIONAL A/C LANDING                                | OPS          | TWINING           |
|          | T41      | ESCAPEES-LIST OF ARRIVALS AT ESCOM                              | OPS          | SPAATZ            |

0 5 3 0

| DATE   | EC NR  | SUBJECT                                    | FROM          | TO                                     |
|--------|--------|--|---------------|--|
|        | T529   | FRANTIC 3-TASKFORCE                        | STRO          | TWINING<br>EAKER                       |
|        | T530   | FRANTIC 3-TASKFORCE                        | CULLEN        | TWINING                                |
|        | T536   | MISSION 3-24 JULY PLANS                    | STRO-<br>THER | SPAATZ, EA<br>FOR TWINING<br>SPAATZ&EA |
| 24JULY | T540   | FRANTIC 3-SCRUBBED                         | CULLEN        | FOR TWIN.<br>DEANE FOR                 |
|        | T546   | FRANTIC 3-ROUNDUP OF SITUATION             | CULLEN        | WALSH<br>DEANE FOR                     |
| 25JULY | JK1414 | M20277 IS UNDERSTOOD                       | CULLEN        | WALSH<br>SPAATZ                        |
|        | T558   | HIGHBALL CLEARANCE                         | OPS           | EA TO POLIF<br>EA, SPAATZ              |
|        | T559   | FRANTIC 3-AIRBORNE                         | OPS           | TWI, DEANE<br>EAKER FOR                |
|        | T561   | FRANTIC PLANS-GORUND ECHELON               | OPS           | TWINING<br>DEANE FOR                   |
|        | T568   | RELAY OF SPAATZ-UG5287                     | OPS           | WALSH                                  |
|        | T572   | P-38 MECHANICS LEAVING                     | OPS           | SPAATZ                                 |
| 26JULY | T575   | FRANTIC 3-RETURN TO HOME BASES             | OPS           | EA FOR TWI<br>DEANE                    |
|        | T576   | FRANTIC 3-25JULY MISSION RESULT            | OPS           | DEANE                                  |
|        | T579   | FRANTIC 3-RETURN TO HOME BASES             | OPS           | EA FOR TWI<br>&STRO, SPA               |
| 27JULY | JK1479 | RELAY OF SPAATZUX61462 TO MOSCOW           | CG            | DEANE FOR<br>WALSH                     |
|        | T589   | FRANTIC-29 JULY MISSION RETURNING TO ITALY | OPS           | EA FOR TWI<br>SPA FOR                  |
|        | T596   | DROOPSNOOT-RECON RESULTS                   | OPS           | SUTTERLIN                              |
|        | JK1496 | QUERY ON UG5526 (GAF)                      | OPS           | DEANE                                  |
| 28JULY | T604   | TARGET INFO-OIL REFINERIES                 | OPS           | EAKER                                  |
|        | T605   | DROOPSNOOT-POSTPONEMENT OF PROJECT         | OPS           | DEANE                                  |
|        | T606   | TARGET-REQUEST FOR IT                      | OPS           | EAKER<br>SPAATZ, EA                    |
|        | T608   | FUTURE FRANTIC PLANS                       | OPS           | DEANE<br>EA, SPA, TWI                  |
| 29JULY | T614   | MASON MISSION ATD                          | OPS           | DEANE, WALSH                           |
|        | JK1534 | EVASION INFO-TRYING TO GET IT              | INTEL         | SPA ATT<br>WEICKER                     |
|        | JK1536 | PRISONER INTERROGATION-GAF DISPOSITION     | INTEL         |  |
|        | JK1525 | ANSWER TO RUSSIAN WASTAGE REPORT           | CULLEN        | SPAATZ                                 |
| 30JULY | T637   | TARGETS-PLANS OF LSAAF ANSWERED            | CULLEN        | EAKER                                  |
|        | JK1538 | GAF DISPOSITION-REPORT ON                  | INTEL         | EA, SPA,<br>DOOLITTLE<br>DEANE FOR     |
|        | T642   | FRANTIC PLANS-OIL REFINERIES PROPOSED      | OPS           | WALSH                                  |

0431



| DATE    | ED. NB   | SUBJECT                                | ORIG.        | TO                   |
|---------|----------|--|--------------|----------------------|
| 15 JULY | JK1257   | 50 GAL AMMO-GET TOGETHER WITH TRAINING | CWS          | TWINING              |
|         | JK1268   | NO INFO ON MECHANICS-READY FOR MISSION | CULLEN       | TWINING              |
| 16 JULY | JK1264   | SOVIETS TOLD ON 18 JULY PLANS          | CULLEN       | TWINING<br>DAENE FOR |
|         | JK1276   | PX SITUATION                           | CULLEN       | WALSH<br>SPAATZ FOR  |
| 17 JULY | JK1294   | NEEDS OF BOMBS FOR MISSIONS            | ORD          | SCHWARTZ             |
|         | T462     | ESCOM F-5 SITUATION                    | OPS          | POLIFKA              |
|         | T453     | MISSION-NONE TILL FUTURE NOTICE        | OPS          | EC BASES             |
| 18 JULY | T473     | QUERY WHAT PLAN WILL BE USED           | OPS          | TWINING              |
| 19 JULY | T477     | FRANTIC 3-NOT YET ARRIVED              | OPS          | EAKER                |
|         | T481     | FRANTIC 3-NOV TOLD OF PLAN B           | OPS          | TWINING              |
| 20 JULY | JK1344   | ROUNDUP ON RETURN BY WALSH             | CG           | SPAATZ               |
|         | T455     | SOVIETS TOLD OF IG 0330                | OPS          | TWINING              |
|         | JK1342   | EC SHOULD MOVE-STILL WANT TG SHED      | CG           | CONNOLLY             |
|         | T489     | PRU ENTRY GATES                        | OPS          | POLIFKA              |
|         | (065182) | RELAY OF MESSAGE 065182 TO MOSCOW      | CG           |                      |
|         | T495     | SOVIETS NOTIFIED-WE'RE READY           | OPS          | TWINING              |
| 21 JULY | JK1363   | RUSSIAN ADVANCE AND ESCOM              | CG           | SPAATZ               |
|         | JK1365   | WALSH ON ESCOM PLANS                   | CG           | SPAATZ<br>SPAATZ &   |
|         | T498     | SOVIETS TOLD OF CM 355                 | OPS          | POLIFKA<br>DEANE     |
|         | T499     | FRANTIC 3-DATA                         | OPS          | SPAATZ,<br>POLATRI   |
|         | T500     | 90 FRANTIC 3-SOVIETS, DEANE TOLD       | OPS          | SPAATZ<br>SPA, EAK   |
|         | T502     | DROOPSHOOT SITUATION                   | OPS          | TWINING              |
| 22 JULY | T515     | FRANTIC 3-PLANS FOR TASKFORCE          | CG           | TWINING              |
|         | T517     | FRANTIC 3-PLANS                        | OPS          | 560-561<br>EAKER     |
|         | T522     | FRANTIC 3-TASK FORCE                   | OPS          | TWINING<br>EAKER     |
| 23 JULY | T523     | FRANTIC 3-ARRIVALS                     | OPS          | TWINING              |
|         | T526     | FRANTIC 3-A/C DAYTIME ALERT            | OPS          | FTRS AT<br>560       |
|         | T527     | FRANTIC 3-TASKFORCE                    | STRO<br>THER | 560                  |

0 4 2 1  
0 5 3 2



HEADQUARTERS EASTERN COMMAND, U.S. STRATEGIC AIR FORCES IN EUROPE  
 OUTGOING MESSAGE

|                |                   |                                |
|----------------|-------------------|--------------------------------|
| PRECEDENCE     | URGENT            | DEF. CMDR'S<br>INITIALS        |
| CLASSIFICATION | <del>SECRET</del> | ORIGINATOR<br>A. A. KESSLER    |
| DATE           | 31 AUGUST 1944    | DUTY O'S<br>INITIALS <i>CF</i> |
| SERIAL NO.     | JK-2432           | TIME CLRD.                     |

TO: JHRH

BOMB LINE DESCRIBED IN OUR JIG KING TWO THREE FIVE SEVEN NO LONGER APPLICABLE  
 PD THIS MESSAGE WAS SUPERSEDED SAME DATE BY OUR JIG KING TWO THREE SIX ZERO  
 WHEN PROBING DETERMINED SOVIET TROOPS WERE ALREADY NEAR SUGGESTED LINE PD  
 SOVIETS HAVE NOW TAKEN PLOESTI WHICH WAS ON PROPOSED LINE PAREN TO DEARE FROM  
 KESSLER SIGNED WALSH TOPSEC JIG KING TWO FOUR THREE ONE PAREN BY REQUEST THAT  
 SOVIETS PROPOSE A BOMB LINE HAS NOT YET BEEN ANSWERED AND IT IS ON THIS POINT  
 THAT YOUR ASSISTANCE IS NEEDED PD NO BOMB LINE NOW EXISTS AND WALKER SUGGESTS THAT  
 ONE BE ESTABLISHED EVEN IF IT IS NECESSARY TO CHANGE IT OFTEN

JK 2432



REFERENCES:

THE MAKING OF AN EXACT COPY OF THIS MESSAGE IS FORBIDDEN. ONLY SUCH  
 EXTRACTS AS ARE ABSOLUTELY NECESSARY WILL BE MADE AND PROPERLY  
 CLASSIFIED

0 5 3 3

ROUTINE

~~SECRET~~

30 AUGUST 1944

JK-2402

95

JMRR

SUBJECT IS RADIO TELETYPE CIRCUIT BETWEEN MOSCOW AND POLTAVA PAREN TO DEANE FROM  
KESLER SIGNED WALSH TOP SEC JIG KING TWO FOUR ZERO TWO PAREN IN VIEW OF UNCERTAIN  
FUTURE THIS PROJECT BELIEVE ADVISABLE TO RECONSIDER THIS INSTALLATION PD NONE OF  
EQUIPMENT HAS ARRIVED HERE AND CONSIDER LIKELY NONE HAS LEFT STATES PD SINCE WAR  
INDICATED NEED OF EQUIPMENT IN OTHER THEATERS IT MAY BE POSSIBLE TO HAVE IT  
DIVERTED BEFORE SHIPMENT TO RUSSIA IS INITIATED PD REQUEST YOU TAKE WHATEVER ACTION  
YOU CONSIDER APPROPRIATE



clnd 0752 JK-2402

W

0 5 3 4

HEADQUARTERS EASTERN COMMAND, U.S. STRATEGIC AIR FORCES IN EUROPE  
 OUTGOING MESSAGE

|                |              |                           |
|----------------|--------------|---------------------------|
| PRECEDENCE     | PRIORITY     | DEP. CMDR'S<br>INITIALS   |
| CLASSIFICATION | SECRET       | ORIGINATOR<br>COL MUNDALL |
| DATE           | 29 AUGUST 44 | DUTY O'S<br>INITIALS      |
| SERIAL NR      | JK 2396      | TIME CLRD. 1630Z          |

TO: JJHL JARR

PERMINOV ADVISES NO RPT NO INFORMATION FROM MOSCOW YOUR PROPOSAL NEW BOMB  
 LINE PD PAREN EAKER FROM KESLER INFO DEANE SIGNED WALSH CITE TOP SECRET  
 JIG KING TWO THREE NINE SIX PAREN INQUIRY WAS MADE BY PERMINOV BY TELEPHONE  
 THIS AFTERNOON WITH NO RESULTS

JK-2396

~~SECRET~~

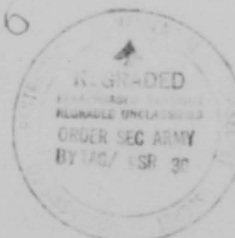

REFERENCES:

THE MAKING OF AN EXACT COPY OF THIS MESSAGE IS FORBIDDEN. ONLY SUCH  
 EXTRACTS AS ARE ABSOLUTELY NECESSARY WILL BE MADE AND PROPERLY  
 CLASSIFIED

0535

HEADQUARTERS  
EASTERN COMMAND  
USSTAF  
OUTGOING MESSAGES

|                |          |
|----------------|----------|
| PRECEDENCE     | PRIORITY |
| CLASSIFICATION | SECRET   |

COLONEL L. B. HICKAM  
ORIGINATOR  
*lh*  
APPROVED, ADJUTANT.

DATE 29 AUGUST 1944

SRL NR

TO: JY2A

MAKING RESPONSE TO YOUR PAPER ONE EIGHT SIX SIX SEVEN PAPER TO SECRET FOR  
G-ARMY FROM HICKAM SIGNED WALSH CITE JIG KING

TOP SECRET PAPER ITEM ONE CDM BULK OF MICHIGAN  
ONE SIX SUPPLIES LEFT POLTAVA BEFORE RECEIVING MINE MRAY TWO MINE FIVE  
THREE SEVEN PD LACK OF MARKING MATERIAL HERE PREVENTS MARKING WHAT LITTLE  
REMAINS PD THEREFORE CMA FORCED TO ASK THAT PRESCRIBED MARKINGS ACCOMPLISHED  
TEHRAN PD MISTER WHITMAN AND SERGEANT MCCULLOCH DEPART FOR TEHRAN WITH  
LAST OF SUPPLIES ABOUT ONE SEPTEMBER AND ARE INSTRUCTED TO ASSIST IN  
MARKING OF SUPPLIES WHILE THERE PD ITEM TWO CDM WHITMAN AND MCCULLOCH  
WILL LEAVE ON COMPASS ORDERS FROM THE HEADQUARTERS PD HAVING BEEN NO  
REPEAT NO ORDERS ASSIGNING LT MURPHY AND SERGEANT ROSSIGNO TO US CMA  
WE ARE NOT ISSUING ORDERS TRANSFERRING THEM OUT ~~OF THIS COMMAND~~

JK-2391

SECRET

JK 2071

clrd-14492

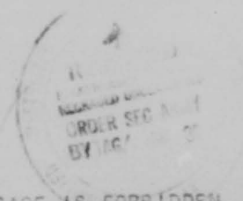

THE MAKING OF AN EXACT COPY OF THIS MESSAGE IS FORBIDDEN. ONLY  
SUCH EXTRACTS AS ARE ABSOLUTELY NECESSARY WILL BE MADE AND PROPERLY  
CLASSIFIED.

0536

HEADQUARTERS EASTERN COMMAND, U.S. STRATEGIC AIR FORCES IN EUROPE  
 O U T G O I N G M E S S A G E

|                |                       |                      |
|----------------|-----------------------|----------------------|
| PRECEDENCE     | THREE URGENT          | DEP. CMDR'S INITIALS |
| CLASSIFICATION | <del>TOP SECRET</del> | ORIGINATOR           |
| DATE           | 29 AUGUST 44          | CCL MUNDELL          |
| SERIAL NR      | JK 2384               | DUTY O'S INITIALS    |
|                |                       | TIME CLRD. 1120Z     |

TO: JBDP JARR

CANNOT RPT CANNOT AGREE WITH RECOMMENDATIONS SUBMITTED IN MILLS MIKE  
 ARAY TWO ZERO SEVEN THREE SIX CONCERNING SHIPMENT OF ITEMS OF SUPPLY  
 AT MURMANSK TO POLTAVA FOR STORAGE PD PAREN SPAATZ FOR KNEER FROM KESSLER  
 SIGNED WALSH INFO DEANE FOR MC HENRY CITE TOP SECRET JIG KING TWO THREE  
 EIGHT FOUR PAREN PRESENT STORAGE FACILITIES HERE OVER CROWDED AND ADDITIONAL  
 NOT RPT NOT AVAILABLE PD OUTSIDE STORAGE IMPRACTICAL HERE DUE TO SEVERITY  
 OF WINTERS PD MOVEMENT OF ALL THESE SUPPLIES AND EQUIPMENT OVER  
 CROWDED SOVIET RAILROAD NOT CONSIDERED POLITIC UNLESS MOVEMENT WEST  
 AND WINTER OPERATIONS ARE ASSURED



REFERENCES:

THE MAKING OF AN EXACT COPY OF THIS MESSAGE IS FORBIDDEN. ONLY SUCH  
 EXTRACTS AS ARE ABSOLUTELY NECESSARY WILL BE MADE AND PROPERLY  
 CLASSIFIED

0537

~~SECRET~~  
PARAPHRASE

ROUTINE

ORIGINATOR: A. A. KESSLER

SECRET [REDACTED]

TO: JJHL, JMRR

28 AUGUST 1944

NO: JK-2361

THE 7 B-17'S AND 1 B-24 WILL REQUIRE ONLY FERRY CREWS. THE ROUTE TO BE USED IS BY THE WAY OF TEHERAN. WE WILL LET YOU KNOW WHEN OTHER AIRCRAFT ARE OPERATIONAL. 4 P\*38 WILL ALSO RETURN TO YOU OVER THE TOP. SUFFICIENT VISAS ARE NOT AVAILABLE AT TEHERAN. DEANE HAS BEEN REQUESTED TO OBTAIN 44 ADDITIONAL VISAS.



JK 2361  
0538

HEADQUARTERS  
EASTERN COMMAND  
USSTAF  
OUTGOING MESSAGES

|            |              |                |           |            |         |
|------------|--------------|----------------|-----------|------------|---------|
| PRECEDENCE | URGENT       | CLASSIFICATION | SECRET    | ORIGINATOR | GWKK/LR |
| DATE       | 27 AUGUST 44 | APPROVED,      | ADJUTANT. |            |         |
| SRL NR     | JK 2360      | TO:            | JUL JBR   |            |         |

CONFERENCE THIS MORNING WITH PER-100V AND TELEPHONE MESSAGE IN MY PRESENCE PD  
 PAV'S WASH INFO DEAR FROM KENNER SIGNED WASH CITE TOP SECRET JIG KING  
 THE TROOP SEA BOMB ALL FOUR NOT ALL FOUR AIRBORNE PROPOSED IN YOUR SIG  
 WILLIAM NINE THREE ITEM EAST AND NOW IN SOVIET HANDS AND SHOULD NOT BE  
 ATTACKED PD WAGON APPEARED GREATLY CONCERNED THAT RUMORS ARE BEING  
 REPORTED OF YOU WITHOUT INFORMING THEM PD NOT SUBJECT TO YOUR PROPOSED  
 LINE IN SIX WILLIAM NINE THREE ITEM EAST ALSO SUBMITTED THREAT PD SOVIET  
 TROOPS AND NOW ON THE HILLS FROM PLANTI SO ITS SUGGESTED THAT SOVIET  
 SHOULD ~~XXXXXXXXXX~~ A GOOD LINE SINCE YOUR PROPOSAL OBVIOUSLY TOO CLOSE TO  
 THEIR FRONT LINE PD WILL ADVISE YOU THEIR PROPOSAL WHEN RECEIVED



THE MAKING OF AN EXACT COPY OF THIS MESSAGE IS FORBIDDEN. ONLY  
 SUCH EXTRACTS AS ARE ABSOLUTELY NECESSARY WILL BE MADE AND PROPERLY  
 CLASSIFIED.

7 4 2 8  
0 5 3 9



~~SECRET~~  
SECRET  
URGENT  
PRIORITY

COMMANDING GENERAL  
R

27 August 1944

JSHL

PROPOSAL TO ATTACK AIRFIELDS AT BILISTRA CMA FOCBANI CMA BUZAU AND SIBLEA

YOUR CABLE JIG WILLIAM NINE TWO ITEM EASY SUBMITTED TO RUSSIAN GENERAL

REBIRNOV TODAY CMA TWO SEVEN AUGUST BAREN TO BAKER FROM KESLER SIGNED WALSH

CITE JK 2359 PD NO INFORMATION HERE AVAILABLE ON AIRFIELD

AT SIBLEA PD REQUEST YOU CONFIRM SPELLING AND ADVISE THIS HEADQUARTERS PD

JK - 2359

clnd 1942

~~SECRET~~  
SECRET



JK 2359

0540

HEADQUARTERS  
EASTERN COMMAND  
USSTAF  
OUTGOING MESSAGES

|                |                       |                     |
|----------------|-----------------------|---------------------|
| PRECEDENCE     |                       |                     |
| CLASSIFICATION | PRIORITY              | GENERAL KESSLER     |
|                | <del>TOP SECRET</del> | <i>JK</i>           |
| DATE           |                       | APPROVED, ADJUTANT. |
| SRL NR         | 27 AUGUST 44          |                     |
| JK 2358        | TO: JHL               |                     |

PROPOSAL FOR NEW BOMB LINE YOUR JIG WILLIAM NINE THREE ITEM EASY  
GIVEN PERMINOV TODAY PD PAREN ~~0178~~ EAKER FROM KESSLER SIGNED WALSH  
SITE TOP SECRET JIG KING THREE TWO FIVE EIGHT PAREN ALSO FORWARDED  
DEANE FOR ACTION THAT END PD WILL ADVISE SOVIET REACTION AS SOON AS  
RECEIVED

JK-2358



22nd 19212

THE MAKING OF AN EXACT COPY OF THIS MESSAGE IS FORBIDDEN. ONLY  
SUCH EXTRACTS AS ARE ABSOLUTELY NECESSARY WILL BE MADE AND PROPERLY  
CLASSIFIED.

7430  
0541

HEADQUARTERS  
EASTERN COMMAND  
USSTAF  
OUTGOING MESSAGES

|                |                   |                     |
|----------------|-------------------|---------------------|
| PRECEDENCE     | PRIORITY          | ORIGINATOR          |
| CLASSIFICATION | <del>SECRET</del> | ORIGINATOR          |
| DATE 27 AUG 44 |                   | APPROVED, ADJUTANT. |
| SRL NR         | TO:               |                     |
| JK 2357        | JERR              |                     |

REPLY OF MESSAGE PAGES DEARS FBI KESSLER CITY TOP SECRET JIG KING TWO  
THREE FIVE SEVEN EIGHT NINE (MESSAGE)  
UNQUOTE PROPOSAL BEING FURNISHED PERMITS IN WRITING TOMORROW.

JK-2357

~~SECRET~~  
SECRET



THE MAKING OF AN EXACT COPY OF THIS MESSAGE IS FORBIDDEN. ONLY  
SUCH EXTRACTS AS ARE ABSOLUTELY NECESSARY WILL BE MADE AND PROPERLY  
CLASSIFIED.

7451  
0542

HEADQUARTERS  
EASTERN COMMAND  
USSTAF  
OUTGOING MESSAGES

|                |              |                     |
|----------------|--------------|---------------------|
| PRECEDENCE     | PRIORITY     | GEN KESSLER         |
| CLASSIFICATION | SECRET       | ORIGINATOR          |
| DATE           | 27 AUGUST 44 | APPROVED, ADJUTANT. |
| SRL NR         | TO:          |                     |
| 2356           | JJHL JMRR    |                     |

EXCESS SUPPLIES OF ALL BRANCHES BEING PREPARED FOR GRADUAL EVACUATION IMMEDIATELY BY AIR AND RAIL PD REQUEST AUTHORITY TO REDUCE PERMANENT STRENGTH TO LESS THAN ONE TWO ZERO ZERO BY GRADUAL AIR EVACUATION PD PAPER ORDER FOR WALSH INFO DEARE FROM KESSLER SIGNED WALSH CITE JIG KING TWO THREE FIVE SIX PAPER IF THIS IS DONE STRENGTH OF ANY INCOMING MISSION MUST BE COVERED BY EFFECTIVE PERSONNEL REMAINING HERE PD REQUEST THAT CONSIDERATION BE GIVEN TO AIR TANK CHARLIE PLACING ADDITIONAL AIRCRAFT ON THIS NON PD THIS ACTION WILL SPEED UP EVACUATION OF EXCESS SUPPLIES ETCETERA PD HAS CONSIDERATION BEING GIVEN TO HELPING SUPPLIES AND EQUIPMENT AT BOTHEN PORTS PD INFORMATION HERE INDICATES THAT ABOUT ONE EIGHT SEVEN NINE TONS ARE EMBARKED CMA AIR CORPS SUPPLIES CMA SIGNAL SUPPLIES AND EQUIPMENT PHOTO SUPPLIES CMA ORGANIZATION EQUIPMENT FOR ENGINEER BATTALION CMA NIGHT FIGHTER CONTROL EQUIPMENT CMA THREE NINE PREFABRICATED BARRACKS AND MISCELLANEOUS SUPPLIES PD ALSO ONE FOUR CMA FOUR ZERO ZERO TONS STEEL WAITING PD BELIEVE THAT IF IT CAN BE ARRANGED THAT IT IS ADVISABLE TO HOLD EVERY THING AT BOTHEN PORTS EXCEPT THE BARRACKS UNTIL DECISION ON FRANTIC FUTURE IS GIVEN

JK 2356



THE MAKING OF AN EXACT COPY OF THIS MESSAGE IS FORBIDDEN. ONLY SUCH EXTRACTS AS ARE ABSOLUTELY NECESSARY WILL BE MADE AND PROPERLY CLASSIFIED.

0543

HEADQUARTERS  
EASTERN COMMAND  
USSTAF  
OUTGOING MESSAGES

|                |                    |                     |
|----------------|--------------------|---------------------|
| PRECEDENCE     | PRIORITY           | COL MUNDELL         |
| CLASSIFICATION | SECRET             | ORIGINATOR          |
| DATE           | 23 AUGUST 44       | APPROVED, ASSJYANT. |
| SRL NR         | TO: JBPD JJHL JJCQ |                     |
| JK 2069        |                    |                     |

RESTRICTION TO ONLY ONE RPT ONE CORRIDOR SOUTH OF ODESSA AS STATED JIG KING  
TWO ZERO SIX THREE OF TWO THREE AUGUST PRECLUDES ANY BOMBER OR RECON SHUTTLE  
OPERATIONS FROM UNCLE KING UNTIL FURTHER SOVIET NOTICE PD.PAREN SPAATZ CMA  
EAKER CMA WALSH CMA DOOLITTLE AND TWINING FROM KESSLER CITE TOP SECRET JIG  
KING TWO ZERO SIX NINE PAREN ALSO RESTRICTS ONE FIVE AIR FORCE SHUTTLE OPERATIONS  
AND RECON ACTIVITY TO BALKANS PD APPARENTLY WE ARE NOT RPT NOT WELCOME OVER POLAND  
PD RECOMMEND THAT PRU CONTINUE FROM ITALY USING ODESSA CORRIDOR AND THAT A NEW  
FRANTIC SEVEN BE SET UP AND PROPOSED TO SOVIET PD SUCH MISSION TO UTILIZE  
ODESSA CORRIDOR AND RETURNING TO ITALY THE FOLLOWING DAY PD HARRIMAN HAS BEEN  
ADVISED THESE DEVELOPMENTS

JK-2069



THE MAKING OF AN EXACT COPY OF THIS MESSAGE IS FORBIDDEN. ONLY  
SUCH EXTRACTS AS ARE ABSOLUTELY NECESSARY WILL BE MADE AND PROPERLY  
CLASSIFIED.

0544

HEADQUARTERS  
EASTERN COMMAND  
USSTAF  
OUTGOING MESSAGES

|                |              |                     |
|----------------|--------------|---------------------|
| PRECEDENCE     | URGENT       | GEN KESLER          |
| CLASSIFICATION | SECRET       | OFFICIAL FOR        |
| DATE           | 23 AUGUST 64 | APPROVED, ADJUTANT. |
| SRL NR         | TO:          |                     |
| JK 2065        | JRRR         |                     |

(RELAY THE FOLLOWING TWO MESSAGES WITH THE ADDED INFORMATION)

ONLY FOR YOUR INFORMATION FOLLOWING TWO MESSAGES SENT TO YOU PD PAGE DEARS  
FOR MC HENRY AND HARRISON FROM KESLER SIGNED WALSH CITE TOP SECRET JIG KING  
TWO ZERO SIX FIVE PAREN ONE SEVEN ZERO ZERO HOURS ZEBRA TWENTY TWO AUGUST TARE  
TWO NINE FOUR MESSAGE NUMBER ONE PD MESSAGE TWO CMA JIG KING TWO ZERO SIX THREE  
TWENTY TWO AUGUST CMA TWO THREE ZERO ZERO HOURS ZEBRA

JK-2065



THE MAKING OF AN EXACT COPY OF THIS MESSAGE IS FORBIDDEN. ONLY  
SUCH EXTRACTS AS ARE ABSOLUTELY NECESSARY WILL BE MADE AND PROPERLY  
CLASSIFIED.

0545

~~SECRET~~ CP PRIORITY

SECRET

A. A. KESSLER

JK

23 AUGUST

JK-2064

USAF ME (CAIRO)

THE AT THE IMPORTANT MESSAGE CONCERNING FRANTIC SERVICE AND OTHER FRANTIC OPERATIONS  
SENT UNDER YOUR NOTICE AND YOUR INFORMATION PD PARANT TO GIL'S FOR WALKER FROM ASSUME  
SIGNED WALKER CITY JIG KING TWO ZERO SIX FOUR TWO SECRET FARM RESEARCH WALKER  
TARE TWO NINE FOUR OF TWO TWO AUGUST AND JIG KING TWO ZERO SIX THREE OF TWO THREE  
AUGUST PD AUGUST YOU OBTAIN COPIES UPON ARRIVAL AT CASERTA.

JK-2064

~~TOP~~

REGRADED  
ORDER SEC ARMY  
BY 107 51 31

0546



~~SECRET~~

GSH KESSLER

23 AUGUST 1944

*JK*

JK 2063

JRFD JBAP JJHL JJCM

DISREGARD RPT DISREGARD OUR TANK TWO NINE FOUR OF TWO TWO AUGUST PD NOTICE RECEIVED  
 ZERO ONE THREE ZERO TWO THREE AUGUST FROM MOSCOW THAT APPROVAL OF PROPOSED PRACTIC  
 SEVEN WITHIN PD THEIR REQUEST FOR US TO ATTACK TARGETS GELATI ETC ALSO RPT ALSO  
 KITCHEN PD PARKS TO SPATZ CDR DOOLITTLE CMA BAKER AND TRAINING FROM KESSLER SIGNED  
 WALSH CITE JIG KING TWO ZERO SIX THREE TOP SECRET PAGE REASON GIVEN WAS THAT SOVIET  
 SUCCESSES IN THE SOUTH MADE THESE ATTACKS UNNECESSARY AND THAT WE MIGHT EXPECT  
 GREAT THINGS IN A FEW DAYS PD TWO FOUR AUGUST AND THEREAFTER THE ONLY RPT ONLY  
 CORRIDOR OVER SOVIET FRONT LINES FOR BOTH BOMBERS AND PETER ROGER UNCLE WILL BE SOUTH  
 OF ODESSA RPT SOUTH OF ODESSA PD THIS WILL BE THE ONLY RPT ONLY CORRIDOR OVER THE  
 ENTIRE RPT ENTIRE SOVIET FRONT LINES UNTIL FURTHER NOTICE FROM SOVIETS PD REASON PER  
 RADICAL CHANGE OTHER THAN THAT GIVEN ABOVE UNKNOWN PD PERMINOV STATED THAT PLOESTII  
 AND OTHER BALKAN TARGETS COULD BE PROPOSED AND ATTACKED PROVIDED CLEARANCE THERE FOR WAS  
 OBTAINED FROM SOVIET AND THE ABOVE CORRIDOR WAS USED

JK-2063



0547

one  
 HEADQUARTERS  
 EASTERN COMMAND  
 USSTAF  
 OUTGOING MESSAGES

|                |                |                     |
|----------------|----------------|---------------------|
| PRECEDENCE     | AUGUST         | COLONEL HAMPTON     |
| CLASSIFICATION | SECRET         | ORIG. JATER         |
| DATE           | 20 AUGUST 1944 | APPROVED, ADJUTANT. |

SRL NR  
 T-294

TO: JAIL JCCQ YBPD

FROM SOVIETS FOLLOWING TARGETS HAVE BEEN REQUESTED FOR ATTACK ON OR BEFORE TWO FOUR AUGUST PD TARGET ONE COLON GALATZ CMA CHART NUMBER ONE ONE DASH FIVE ONE DASH NAN ABLE CMA MARSHALLING YARD NUMBER TWO REPEAT TWO TO RECEIVE MAXIMUM EFFORT WITH PREFERENCE TO NORTHERN PORTION OF TARGET PD TARGET TWO COLON BRILA CMA CHART NUMBER ONE ONE DASH FIVE TWO DASH NAN ABLE CMA MAIN EFFORT IN MARSHALLING YARD AND PORT AREA WITH PREFERENCE TO NORTH PART OF MARSHALLING YARD PD TARGET THREE COLON RUZAN CMA CHART NUMBER ONE ONE DASH ONE TWO NAN ABLE CMA TO HIT MARSHALLING YARDS BY SOUTH OF TOWN PD ROUTE FROM ABOVE TARGETS TO CROSS FRONT LINE SOUTH OF ODESSA OVER SEA AT OVER FIVE THOUSAND FEET ALTITUDE PD RUSSIANS ADVISE DUE TO THEIR ADVANCE IN THIS AREA THAT BARRS AND PORTS ARE CARRYING HEAVY LOADS OF EVACUATING ENEMY PD IT PLAS TO STRIKE THE ABOVE TARGETS CAN NOT BE LAID ON BY TWO FOUR AUGUST REQUEST THAT EASTERN COMMAND BE ADVISED DAILY AS TO WHEN THESE EAR TARGETS CAN BE HIT PD SOVIET ADVANCE IN THIS AREA MAKES CLOSE COORDINATION NECESSARY PD PAREN SPATZ TAKER AND THINKING FROM KESSLER SIGNED SALON TOP SECRET TAKE TWO NINE FOUR PAREN SET SUBJECT PD PLAN CONTEMPLATED IN YOUR CHARLIE SUGAR ONE TWO FIVE EIGHT NAN TAKE ARE APPLIED BY SOVIETS WITH NO PREFERENCE SHOWN PD THEY REQUEST FRONT LINE TO BE MAINTAINED AT FIVE THOUSAND FEET AT THE FOLLOWING PLACES COLON NORTHERN ROUTE OF JAROSLAV CMA CENTRAL ROUTE CROSS AT BOTOSANI CMA SOUTHERN ROUTE CROSS SOUTH OF ODESSA OVER SEA PD SINCE WEATHER CONDITIONS MAY NOT ALLOW FRANTIC SIX THE MAKING OF AN EXACT COPY OF THIS MESSAGE IS FORBIDDEN. ONLY SUCH EXTRACTS AS ARE ABSOLUTELY NECESSARY WILL BE MADE AND PROPERLY

REGRADED  
 ORDER SEC ARMY  
 BYTAG/USP 30

T 294  
 0 5 4 8

HEADQUARTERS  
EASTERN COMMAND  
USSTAF  
OUTGOING MESSAGES

|                |                    |  |                       |
|----------------|--------------------|--|-----------------------|
| PRECEDENCE     |                    |  | ORIGINATOR <i>JOK</i> |
| CLASSIFICATION | <del>SECRET</del>  |  | APPROVED, ADJUTANT.   |
| DATE           |                    |  |                       |
| SRL NR         | TO: PAGE TWO T-294 |  |                       |

SUGGEST FRAUDIC SEVEN FROM ITALY COME NEXT AND THAT THE TARGETS REQUESTED  
 BY SOVIETS BE USED BY THEM ON TWO FOUR AUGUST PD REQUEST BE BE IMMEDIATELY  
 ADVISED OF ACTION TAKEN

~~SECRET~~

*3-21-50 3:40 PM 1950*

T-294 (PAGE 2)

THE MAKING OF AN EXACT COPY OF THIS MESSAGE IS FORBIDDEN. ONLY  
 SUCH EXTRACTS AS ARE ABSOLUTELY NECESSARY WILL BE MADE AND PROPERLY  
 CLASSIFIED.

7 4 3 8  
 0 5 4 9

HEADQUARTERS  
EASTERN COMMAND  
USSTAF  
OUTGOING MESSAGES

|                 |                |                      |
|-----------------|----------------|----------------------|
| PRECEDENCE      | TIME           | DATE OF DELIVERY     |
| CLASSIFICATION  | ROUTE          | ORIGINATOR           |
| DATE OF ARRIVAL | CLASSIFICATION | APPROVED, ASSISTANT. |
| SRL NR          | TO:            |                      |

JK-2047

TO: JSPD

URGENT 0800Z 04 APR 68  
FM JCRC  
TO JSPD  
INFO JCS  
SUBJ: [Illegible]

BAKER

TWO ZERO  
FOUR SEVEN

TYPE MATERIAL

ING

JK-2047



THE MAKING OF AN EXACT COPY OF THIS MESSAGE IS FORBIDDEN. ONLY SUCH EXTRACTS AS ARE ABSOLUTELY NECESSARY WILL BE MADE AND PROPERLY CLASSIFIED.

0550

HEADQUARTERS  
EASTERN COMMAND  
USSTAF  
OUTGOING MESSAGES

|                |                   |                     |
|----------------|-------------------|---------------------|
| PRECEDENCE     | PRIORITY          | GOE MINNELL         |
| CLASSIFICATION | <del>SECRET</del> | ORIGINAL            |
| DATE           | 21 AUGUST         | APPROVED, ADJUTANT. |
| SRL NR         | TO:               |                     |
| JK 2044        | JWD               |                     |

WANT TO WARN YOU THAT UNTIL GANDAM POLITICAL SITUATION IS ADJUSTED CIA  
BY OPINION IS THAT OTHER MISSIONS MAY ALSO BE DISAPPROVED FOR SPATE  
PERSONAL FROM WASH DC: JIG KING TO: JWD FOUR FOUR PAGE BELIEVE HA  
EVER WE SHOULD CONTINUE TO MAKE REQUESTS FOR MISSIONS

JK-2044



THE MAKING OF AN EXACT COPY OF THIS MESSAGE IS FORBIDDEN. ONLY  
SUCH EXTRACTS AS ARE ABSOLUTELY NECESSARY WILL BE MADE AND PROPERLY  
CLASSIFIED.

0551

HEADQUARTERS  
EASTERN COMMAND  
USSTAF  
OUTGOING MESSAGES

|                |                   |
|----------------|-------------------|
| PRECEDENCE     | PRIORITY          |
| CLASSIFICATION | <del>SECRET</del> |

COL. MURPHY

ORIGINATOR

DATE 22 AUGUST 44

APPROVED, ASJUTANT.

SRL NR

JK 2043

TO:

JMR

TALK WITH PERLINOV REVEALED THAT PROPOSALS FOR FURTHER SIX WERE ENTIRELY  
IN ORDER AND THAT NOTICES AND INFORMATION WERE GIVEN TO SOVIETS IN AMPL  
THIS PD PARK H TO DEMO FOR HAWAIIAN ONLY SIGNED WALTER CITE JIG KING TWO  
~~FROM FOUR 7/11/44~~ FROM THE DISAPPROVAL WAS IN DISCOY AND PERLINOV  
INDICATED THAT PROBABLY FOREIGN OFFICE WOULD ANSWER PD BY INFO 3/18/44 IS  
THAT THE DISAPPROVAL WAS TO BE ASSURED SOME OF THE AIRPLANES COULD PARTICIPATE  
IN ASSISTANCE TO HAWAIIAN PD THERE WAS A DEFINITE INDICATION THAT THERE WOULD  
BE OTHER MISSIONS AND THEREFORE TO BE THIS SITUATION IS TEMPORARY DEPENDING  
ON HAWAIIAN

JK-2043



THE MAKING OF AN EXACT COPY OF THIS MESSAGE IS FORBIDDEN. ONLY  
SUCH EXTRACTS AS ARE ABSOLUTELY NECESSARY WILL BE MADE AND PROPERLY  
CLASSIFIED.

0552

HEADQUARTERS  
EASTERN COMMAND  
USSTAF  
OUTGOING MESSAGES

|                |        |
|----------------|--------|
| PRECEDENCE     | URGENT |
| CLASSIFICATION | SECRET |

P. T. CULLEN, COL., A.C.  
OPERATIONS  
ON/ST. AYOR

DATE 20 AUGUST 1944

APPROVED, WJUYANY.

SRL NR  
T-276

TO: JJHL JJGQ

DOPE IN YOUR ITEM EASY ONE FIVE EIGHT FIVE NAN TARE CORRECT EXCEPT OUR  
SUPPLY SITUATION INDEFINITE UNTIL AFTER FRANTIC SIX OPERATES PD EAKER  
AND ~~XXXX~~ TRAINING FROM CULLEN SINGED WALSH TOP SECRET TARE TWO SEVEN  
SIX PAREN YOU WILL BE INFORMED PRIOR TO FRANTIC SEVEN IF NECESSARY TO  
SEND SUPPLIES FROM ITALY



T-276

THE MAKING OF AN EXACT COPY OF THIS MESSAGE IS FORBIDDEN. ONLY  
SUCH EXTRACTS AS ARE ABSOLUTELY NECESSARY WILL BE MADE AND PROPERLY  
CLASSIFIED.

0553



HEADQUARTERS  
EASTERN COMMAND  
USSTAF  
OUTGOING MESSAGES

|                |                        |  |
|----------------|------------------------|--|
| PRECEDENCE     | URGENT                 | FIT. CULLEN, COL., A.C.<br>OPERATIONS<br>INITIATOR |
| CLASSIFICATION | TOP SECRET             |  |
| DATE           | 20 AUGUST 1944         | APPROVED, ADJUTANT.                                |
| SRL NR         | TO: JSPD JBAF (SOURCE) |  |
| T-275          |                        |  |

LOCAL SOVIETS STATE MOSCOW ORDERS THAT THERE BE NO REPEAT NO SHUTTLE MISSION  
ON TWO ONE AUGUST PD SPAATZ AND DOOLITTLE FROM KESSLER SINGED WALSH TOP SECR  
TARE TWO SEVEN FIVE PAREN ACKNOWLEDGE QUICKLY



THE MAKING OF AN EXACT COPY OF THIS MESSAGE IS FORBIDDEN. ONLY  
SUCH EXTRACTS AS ARE ABSOLUTELY NECESSARY WILL BE MADE AND PROPERLY  
CLASSIFIED.

0554

HEADQUARTERS  
EASTERN COMMAND  
USSTAF  
OUTGOING MESSAGES

PRECEDENCE URGENT  
CLASSIFICATION SECRET

P. T. CULLEN, COL., A.C.  
OPERATIONS  
ORIG. (ATCH)

DATE 20 AUGUST 1944

APPROVED, ASJYATT.

SRL NR TO: JBPD JBAF (BOUNCE)  
T-274

NOTIFIED BY SOVIETS THAT STARTING XXXX TWO ONE AUGUST ONLY PHOT RECON  
UNIT GATES CLEARED ARE PAREN SPAATZ FOR DOOLITTLE EAKER AND TRAINING FOR  
POLIFKA FROM CULLEN SIGNED WALSH TARE TWO SEVEN FOUR PAREN KOLOMYJA XXXX  
PRN FOUR EIGHT DEGREES THREE ZERO MINUTES NORTH TWO FIVE DEGREES ZERO ZERO  
MINUTES EAST PRN CMA JASSY AND TIRASPOL SUBMIT SPECIFIC PLANS FOR ALL

OTHER FLIGHTS



THE MAKING OF AN EXACT COPY OF THIS MESSAGE IS FORBIDDEN. ONLY  
SUCH EXTRACTS AS ARE ABSOLUTELY NECESSARY WILL BE MADE AND PROPERLY  
CLASSIFIED.

0555

URGENT  
SECRET

19 AUGUST 1944

F. T. CULLEN, COL., A. C.  
OPERATIONS  
*JEL*

T-260

JJHL

ALL BASES EASTERN COMMAND HOLD SUGAR DOG <sup>ZERO</sup> TWO TWO ZERO PD PAREN EAKER  
FROM KESSLER SIGNED WALSH TOP SECRET TARE TWO SIX ZERO PAREN SUGAR PETER  
ZERO TWO FOUR FOUR Z RO PAREN TWO PAREN HELD ONLY BY HEADQUARTERS CMA BASES  
ADVISE OF COLORS OF DAY AS NECESSARY PD NO REKOH CARDS HELD PD SUPPLY  
ADEQUATE TO FURNISH ALL TASK FORCES DEPARTING ESCOM NEEDED PD AIR DASH  
GROUND STATION XRAY EIGHT ROGER WILL ALWAYS OPERATE ON FIVE FOUR NINE  
FIVE KILOCYCLES WHEN MISSION ARRIVING OR DEPARTING PD RUSSIAN BEACONS WILL  
BE AVAILABLE ONLY AS ADVISED BY THIS HEADQUARTERS PD AIRDROME CONTROL  
AT ALL BASES GUARD SIX FOUR FOUR ZERO KILOCYCLES PD PIRYATIN VICTOR HOW  
FOX DOG SLANT FOX AND RADIO RANGE SERVICABLE AS PREVIOUSLY INDICATED PD  
RUSSIAN RECOGNITION SIGNALS ARE EXACTLY AS INDICATED BY ESCOM PD SIGNALS  
FOR PERIOD TWO ONE TO THREE ONE AUGUST WILL FOLLOW PD ESCOM BASES OF  
NECESSITY ONLY HOLD VICTOR HOW FOX CRYSTALS ONE TWO SIX POINT ONE EIGHT  
MEGACYLES.

*Answer to #2651*

*T-260*



0556

URGENT  
~~TOP~~ SECRET

P.T. CULLEN, COL., A.C.  
OPERATIONS

19 AUGUST 1944

JBPD JBAF

T-259.

NO REPEAT NO WORD RECEIVED FROM SOVIETS ON TWO ZERO AUGUST MISSIONS PB  
PAREN SPAATZ AND DOOLITTLE FROM KESSLER SIGNED WALSH TOP SECRET TARE TWO  
FIVE NINE PAREN RECOMMEND FRANTIC SIX BE POSTPONED TWO FOUR HOURS PD SAY  
FLIGHT PLANS WILL BE SUBMITTED FOR CLEARANCE UNLESS OTHERWISE NOTIFIED

T-259



0 4 4 0  
0 5 5 7

URGENT  
~~SECRET~~

P.T. CULLEN, COL., A.C.  
OPERATIONS

19 AUGUST 1944

*gkr*

JMRR

T-257

UNDOUBTELY WILL HAVE TO SCRUB FRANTIC SIX FOR TWO ZERO AUGUST BECAUSE  
NEITHER PERMINOV NOR THIS HEADQUARTERS HAVE RECEIVED EITHER YES OR NO  
FROM SOVIET MOSCOW PD PAREN DEANE FOR WALSH FROM KESSLER SIGNED WALSH TOP  
SECRET TARE TWO FIVE SEVEN PAREN THAT IS STUMBLING BLOCK QUERY ACKNOWLEDGE  
RECEIPT WITH TIME

*T-257*



0558

~~TOP SECRET~~  
URGENT

P.T. CULLEN, COL., A.C.  
OPERATIONS

19 AUGUST 1944

JBDP JBAF

T-256

CLEARANCE FOR PLANS ADLE CMA BAKER AND CHARLIE FOR FRANTIC SIX WERE  
SUBMITTED TO SOVIET AUGUST ONE SEVEN BUT HAVE NOT REPEAT NOT BEEN APPROVED  
PD PAREN SPAATZ AND DOOLITTLE FROM KESSLER SIGNED WALSH TOP SECRET TARE  
TWO FIVE SIX PAREN WILL ADVISE YOU AT TWO ZERO ZERO ZERO GEORGE MIKE TARE  
STATUS OF SOVIET CLEARANCE PD MISSION SHOULD BE SCRUBBED IF POSTIVE  
CLEARANCE IS NOT REPEAT NOT RECEIVED

T-256



0 4 4 0  
1 5 5 2

HEADQUARTERS  
EASTERN COMMAND  
USSTW  
OUTGOING MESSAGES COL CULLEN

|                |                   |                     |
|----------------|-------------------|---------------------|
| PRIORITY       | URGENT            | ORIGINATOR          |
| CLASSIFICATION | <del>SECRET</del> | APPROVED, ADJUTANT. |
| DATE AUG 19    |                   |                     |
| SRL NR         | TO: JBPD, JBAP    |                     |
| T-244          |                   |                     |

WHAT IS DATE PAGE TO SPAATZ FOR DOOLITTLE SGT WALSH CITE TIME TWO FOUR FOUR  
PAGE FRONTIER SIX IS SCHEDULED JULY ACKNOWLEDGE URGENT

ADJUTANT GENERAL (244) [unclear]

col cul



T-244

THE MAKING OF AN EXACT COPY OF THIS MESSAGE IS FORBIDDEN. ONLY SUCH EXTRACTS AS ARE ABSOLUTELY NECESSARY WILL BE MADE AND PROPERLY CLASSIFIED.

0560





HEADQUARTERS  
EASTERN COMMAND  
USSTAF  
OUTGOING MESSAGES

|                |          |                      |
|----------------|----------|----------------------|
| PRECEDENCE     | PRIORITY | DEPUTY COMDT FOR OPS |
| CLASSIFICATION | SECRET   | ORIGINATOR           |
| DATE 18 Aug 44 |          | APPROVED, ASJUYATF.  |
| SRL NR         | TO: JJHL |                      |
| T 238          |          |                      |

PHOTO SHUTTLE FROM ITALY DESIRED TO BRING COVER OF ALL TARGETS IN  
THE KRAKOW DASH BRESLAU DASH LODZ AREA AND TO DEVELOP TREND OF  
GERMAN MOVEMENT FROM SOVIET FRONT PD EAKER FROM CULLEN SGD WALSH  
TOPSEC TARE TWO THREE EIGHT PD RECOMMEND IN LINE WITH SPAATZ  
UNCLE KRAY SIX SIX ONE THREE ZERO THAT EMPHASIS BE PLACED ON DAILY  
REPEAT DAILY SHUTTLES FOR DIPLOMATIC REASONS

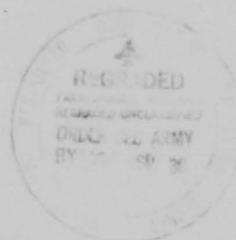

T-238

THE MAKING OF AN EXACT COPY OF THIS MESSAGE IS FORBIDDEN. ONLY  
SUCH EXTRACTS AS ARE ABSOLUTELY NECESSARY WILL BE MADE AND PROPERLY  
CLASSIFIED.

4 5 1  
0 5 6 2

HEADQUARTERS  
EASTERN COMMAND  
USSTAF  
OUTGOING MESSAGES

|                                  |                      |
|----------------------------------|----------------------|
| PRIORITY                         | DEPUTY COMDR FOR OPS |
| CLASSIFICATION <del>SECRET</del> | ORIGINATOR           |
| DATE 18 Aug 44                   | APPROVED, ASSJYANT.  |
| SRL NR<br>T 237                  | TO: JBPD JJHL        |

CRANE DEPARTED FOR ITALY WITH CARNEY NEGATIVES TODAY PD HE HAS BEEN BRIEFED ON CERTAIN TARGETS IN NORTH EASTERN GERMANY FOR WHICH COVER IS NEEDED HERE PD SPANZ FOR DOOLITTLE FOR SHOOP FROM CULLEN SGT WALSH TOP SEC TARE TWO THREE SEVEN PD IS SCHEDULED TO PROCEED TO MOUNT PARK AUGUST ONE NINE PD CRANE SHOULD BE DISPATCHED TO THIS COMMAND ON FIRST SUITABLE WEATHER PD SEE YOUR UNCLE KRAY SIX SIX ONE THREE ZERO AUGUST NINE RECOMMEND SENDING PREVIOUS VISITOR THROUGH ON BOMB DAMAGE ASSESSMENT COVER FOR PRANTIC SIX SHUTTLE



T-237

THE MAKING OF AN EXACT COPY OF THIS MESSAGE IS FORBIDDEN. ONLY SUCH EXTRACTS AS ARE ABSOLUTELY NECESSARY WILL BE MADE AND PROPERLY CLASSIFIED.

7 4 5 2  
0 5 6 3

HEADQUARTERS  
EASTERN COMMAND  
USDAF  
OUTGOING MESSAGES

|                |                |                         |
|----------------|----------------|-------------------------|
| PRECEDENCE     | URGENT         | P. T. CULLEN, COL, A.C. |
| CLASSIFICATION | SECRET         | ORIGINATOR              |
| DATE           | 17 AUGUST 1944 | APPROVED, ASSJ. STAFF.  |
| SGT NR<br>T225 | TO: JRPD       |                         |

ADMITTING THAT FRANTIC SIX UNTIL PAREN SPAATZ FOR DOOLITTLE FROM CULLEN  
SGD WALSH TOP SEC TARE TWO TWO FIVE PAREN ONE NINE AUGUST IS POSTPONED.

ANSWER TO # 2597 (RW 4730)



T-225

THE MAKING OF AN EXACT COPY OF THIS MESSAGE IS FORBIDDEN. ONLY  
SUCH EXTRACTS AS ARE ABSOLUTELY NECESSARY WILL BE MADE AND PROPERLY  
CLASSIFIED.

0564

URGENT  
SECRET

P.T. CULLEN, COL., A.D.  
OPERATIONS

18 AUGUST 1944

JBPD AND JBAF (BOUNCE)

T-220

DELAYED BY GARBLED TRANSMISSION CMA FRANTIC SIX PLANS ABLE CMA  
BAKER CMA CHARLIE HAVE BEEN GIVEN TO SOVIET PD PAREN SPAATZ FOR  
DOOLITTLE FROM CULLEN SIGNED WALSH TOP SECRET TARE TWO TWO ZERO  
PAREN ASSUME PREVIOUS CALL SIGNS SAME PD COME AHEAD JNEKLS

NOTIFIED OTHERWISE



T-220

0565

Q.7

PRIORITY

GEN WALSH

16 AUGUST 1944

USSTAF

HAVE REQUESTED PGO TO HOLD ALL SHIPMENTS FOR MISSION ONE SIX PENDING  
CLARIFICATION THIS PROJECT PAREN FOR SPAATZ FROM WALSH

PAREN EQUIPMENT IN LARGE QUANTITIES IS ARRIVING HYRE BY AIR  
AND ACTION TAKEN BECAUSE OF POSSIBILITY IT MAY HAVE TO BE RETURNED THERE

JK 1944



0566

OP PRIORITY  
~~TOP SECRET~~

GEN WALSH

16 August 1944

POC

NOW REQUEST ALL SUPPLIES FOR MISSION ONE SIX BE RETAINED POC PAREN TO SWEET  
FROM WALSH PAREN PENDING CLARIFICATION THIS PROJECT PD  
HAVE NOTIFIED USSTAF THIS ACTION CONSIDERED NECESSARY AND REQUEST IF ANY SPECIAL  
CONDITIONS INVOLVED TO NOTIFY ME HERE



0567



*W*  
DEFERRED

GEN WALSH

~~TOP SECRET~~  
16 August 1944

USSTAF

DEPARTING ON PRU MISSION TO ITALY ABOUT AUG TWO ZERO IS COL CULLEN PAREN  
TO SPAATZ FROM WALSH TOPSECRET PAREN  
PLANNED HE WILL REMAIN ITALY APPROXIMATELY TEN DAYS



0 5 6 8

URGENT

~~SECRET~~

~~CONFIDENTIAL~~  
CULLEN

AUG 16 1944

JJHL BOUNCE POLIFKA

HIGHBALL SIX AND HIGHBALL SEVEN PAREN EAKER FOR POLIFKA FROM CULLEN SIGNED  
WALSH TOPSECRET TARE TWO ONE SIX PAREN CLEARANCE IN THE MILL.

98



0 4 5 8  
0 5 6 9

~~SECRET~~  
Routine  
SEC

GEN WALSH

USSTAF

IN VIEW OF PRESENT SITUATION WITH REFERENCE TO YOUR UNIT SIX FIVE NINE TWO  
ONE AND OURAD NINE TWO ZERO FOUR ONE ZERO IT IS RECOMMENDED THAT NUMBER OF  
MISSIONS TO UTILIZE THESE BASES FOR PERIOD OF TIME BE DETERMINED TO GIVE  
BASE FOR SUPPLY PLANNING PAREN FOR SPAATE FROM WALSH  
PAREN IT IS SUGGESTED THAT FIVE MISSIONS BE PLANNED BETWEEN NOW AND SEPT ONE  
FIVE AND FIVE MISSIONS AS RESERVE FOR AFTER SEPT ONE FIVE THEN TERMINATE  
SUPPLY TO ELIMINATE ACCUMULATION OF SUPPLIES THAT MAY HAVE TO BE ABANDONED CMA  
CONSEQUENTLY EASING BURDEN ON OVERTAXED RUSSIAN TRANSPORT AND MANUFACTURING  
REQUIREMENTS

~~SECRET~~  
REGRADED  
ORDER SEC ARMY  
17167 (SE 3)

JK 1944

7487  
0570

*78*  
PARAPHRASE

PRECEDENCE:

ORIGINATOR: GENERAL WALSH

CLASSIFICATION: ~~SECRET~~

*16 August*

ONE COPY OF THIS MESSAGE MADE AND IT IS IN THE CG'S SAFE.

JK-1933



0571

PRIORITY  
~~SECRET~~ TOP

P.T. CULLEN, COL, A.C.

15 AUGUST 1944

T203

JJHL, JJCQ(~~SECRET~~), JBPD, JHRR

LIBERATOR REPORTED IN OUR TARE ONE SEVEN EIGHT OF AUGUST ONE FOUR NOW  
REPORTED AS SOUTH AFRICAN FROM MAAF PAREN DEANE CMA EAKER CMA TRINING  
~~AND~~ AND SPAATZ FROM CULLEN SQD WALSH TOP SECRET TARE TWO ZERO THREE  
PAREN CREW SAFE IN SOVIET HANDS LIEUT BURRIS CMA COPILOT PD LIEUT SLEED  
CMA NAVIGATOR AND SERGTS KROSS CMA APPLARD CMA LEWIS GUNNERS PD SGT  
BEITS CMA BOMBARDIER PD SGT PAYNE CMA RADIOMAN PD NOTIFY MR HARRIMAN



*WJ*  
 HEADQUARTERS  
 EASTERN COMMAND,  
 USCAF  
 OUTGOING MESSAGES

|                 |             |                      |
|-----------------|-------------|----------------------|
| PRECEDENCE      | URGENT      | DEPUTY COMDR FOR OPS |
| CLASSIFICATION  | SECRET      | ORIGINATOR           |
| DATE            | 15 AUG 44   | APPROVED, ASSISTANT. |
| SRL NR<br>T 201 | TO: JBD JHL |                      |

BOTH FLIGHT PLANS FOR FRANTIC SIX PAREN SPAATZ AND DOOLITTLE  
 FROM WALSH TARE TWO ZERO ONE TOPSEC PAREN HAVE BEEN DISAPPROVED  
 REPEAT NOT APPROVED BY SOVIETS PD AWAITING NEW FLIGHT PLAN AND  
 NEW TARGET

*REF TO T-201 (FLIGHT PLAN)  
 T-184  
 JK 1947*



*TOP  
 T-201*

THE MAKING OF AN EXACT COPY OF THIS MESSAGE IS FORBIDDEN. ONLY  
 SUCH EXTRACTS AS ARE ABSOLUTELY NECESSARY WILL BE MADE AND PROPERLY  
 CLASSIFIED.

7 4 0 2  
 0 5 7 3

URGENT

GEN WALSH

██████████  
15 August 1944

JBP

BEFORE LEAVING MOSCOW AMBASSADOR HAD WORD FROM FOREIGN OFFICE INDICATING THAT  
PLAN BAKER WOULD NOT REPEAT NOT HAVE SOVIET APPROVAL PAREN SPAATZ FROM WALSH  
██████████ PAREN WE HAVE NO DEFINITE INFORMATION  
HERE AND ARE PUSHING FOR DIRECT OPERATIONAL ANSWER

SEE 2481 (D-60517) - FRANTIC FLIGHT PLAN



0574



HEADQUARTERS  
EASTERN OCEANIC  
US5141  
OUTGOING MESSAGES

|                |   |                       |
|----------------|---|-----------------------|
| PRECEDENCE     | DE PRIORITY                               | DEPUTY COMDR FOR OPS  |
| CLASSIFICATION | <del>SECRET</del> CLEAR                   | ORIGINATOR            |
| DATE           | 15 AUG 44                                 | APPROVED, [Signature] |
| SRL NR         | TO: <del>XXXX</del> SIGNAL MESSAGE CENTER |                       |
| T 107          |   |                       |

REQUEST TRANSMITTAL OF T 145 11 AUG 44 TO JJQQ

FRANTIC 6 DEVELOPMENTS



THE MAKING OF AN EXACT COPY OF THIS MESSAGE IS FORBIDDEN. ONLY SUCH EXTRACTS AS ARE ABSOLUTELY NECESSARY WILL BE MADE AND PROPERLY CLASSIFIED.

7404  
0575

OPS PRIORITY  
SECRET

P. T. CULLEN, COL, A.C.

14 AUGUST 1944

T 100

JCPD JBAF (BOUNCE)

OPERATING FROM ONE ONE ZERO ZERO ZEBRA TO ONE EIGHT ZERO ZERO ZEBRA  
AUGUST ONE SIX PAREN SPAATZ AND DOOLITTLE FROM WALSH TARE ONE NINE  
ZERO TOP SECRET PRN WILL BE RUSSIAN RADIO BEACONS NUMBERS THREE CMA  
FOUR CMA FIVE CMA SIX CMA SEVEN CMA EIGHT AND NINE AT MIRGOROD



4 8 5  
0 5 7 6



OPS PRIORITY  
~~SECRET~~ SECRET

P. T. CULLEN, COL, A.C.

14 AUGUST 1944

T189

JBPD JBAF (SOURCE)

FLIGHT PLAN FOR SIX FRANTIC PRN TO SPAATZ AND DOOLITTLE FROM WALSH  
TOP SECRET TARE ONE EIGHT NINE PRN HAS BEEN TO SOVIETS SUBMITTED

**NI**



T 189  
7400  
0577

PARAPHRASE

Priority ~~Secret~~ ~~SECRET~~

Originator-  
Deputy Commander

14 August 1944

JK 1902

TO: Deane JMRR

Frantic 6 is set up for 16 August. Two flight plans being submitted. Plan A-usual bombing mission, plan B-apparently the unusual mission now under discussion with Soviets. No answer yet on the letter from the Russians. I inspected Roltava base today. base not satisfactory although some improvements.

Kessler (signed Walsh)

REFER TO 2481 (D60513) - FLIGHT PLAN



~~TOP~~  
JK 1902

0578

PRIORITY  
~~SECRET~~

P.T. CULLEN, COL, A.C  
INTELLIGENCE

14 AUGUST 1944

T188

JBPD JBAF (SOURCE)  
JJHL JJCO (SOURCE)

ROMANIA ROMAN AERODROME DASH ONE SMALL AIRCRAFT PRESENT PROBABLY  
 INACTIVE PD TO SPAATZ AND DOOLITTLE CMA EAKER AND THINING FROM WALSH  
 TARE ONE EIGHT EIGHT PRN POLAND TRZEBINJA OIL REFINERY BDA DASH PARTIALLY  
 CLOUD OBSCURED CMA THREE LARGE # ONE ZERO MEDIUM STORAGE TANKS DESTROYED  
 CMA SEVERE DAMAGE TO WAX EXTRACTION OIL COMPOUNDING OIL PURIFICATION  
 AND DISPATCH BUILDINGS CMA SLIGHT DAMAGE TO PETROL TREATMENT BUILDING  
 AND ONE DISTILLATION UNIT PD KRAKOW AERODROME DASH ONE TWO TWO AIRCRAFT  
~~PRESENT CMA ONE JU FIVE TWO ONE CO TWO FOUR FOUR TWO~~  
 PRESENT CMA COLON ONE JU FIVE TWO CMA ONE GO TWO FOUR FOUR CMA TWO HE  
 ONE ONE ONE CMA TWO FW FIVE EIGHT CMA ONE DORNIER TYPE THREE WILLIAM  
 THREE FOUR CMA # ONE ZERO FI ONE FIVE SIX CMA ONE THREE JU EIGHT SEVEN  
 CMA ONE TWO MEDIUM CMA SEVEN SIX SEF CMA ONE SMALL BIPLANE

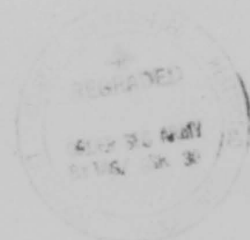

T188

0579

PARAPHRASE

URGENT ~~SECRET~~

14 AUGUST 1944  
P.T.CULLEN

T 184 JMRR

WORKING ON FARNTIC 6 THROUGH GENERAL PERMINOV, AS YOU ASSUME.  
WE HAVE ADVISED HIM AND ROVALEV OF THE MISSION'S UNUSUAL NATURE  
AND ASKED TO DESIGNATE THE AIRFIELDS WHICH SOVIETS WANT HIT.  
POSSIBLE POLITICAL COMPLICATIONS WERE ANTICIPATED.

KESSLER SIGNED WALSH



T-184

0 5 8 0

~~TOP SECRET~~  
URGENT

P.T. CULLEN, COL., A.C.  
OPERATIONS

14 AUGUST 1944

JBPD AND JBAF (BOUNCE)

T-180

SOVIETS REFUSE RPT REFUSE CLEARANCE FOR CAPTAIN CARNEY CMA HIGHBALL TWO  
OVER SUIVALKI PD PRN SPAATZ FOR DOOLITTLE FOR MOUNT FROM CULLEN SGD WALSH  
~~TOP SECRET~~ TARE ONE EIGHT ZERO PRN HAVE RESUBMITTED FOR BIALYSTOK SA  
TIME AND ALTITUDE HOWEVER HOLD CARNEY UNTIL SOVIETS GIVE ASSURANCE OF  
SAFETY





HEADQUARTERS  
EASTERN COMMAND  
USSTAF  
OUTGOING MESSAGES

|                |                      |                       |
|----------------|----------------------|-----------------------|
| PRECEDENCE     | OPS PRIORITY         | DEPUTY COMOP FOR OPS  |
| CLASSIFICATION | SECRET               | ORIGINATOR            |
| DATE           | 14 AUG 1964          | APPROVED, AGENT/ATTY. |
| SRL NR         | TO: JSD JRAF(BOUNCY) |                       |
| 177            |                      |                       |

SAFELY LANDED AT PIYATIN MUSTARDS NUMBER ZERO NINE FOUR AND NINE THREE SEVEN  
PILOTED BY FIRST LIEUT CHARLIE CHARLIE GERRMAN ONE TWO FOUR NINE SIX THREE AND  
SECOND LIEUT DOG FOX JEWELL ONE SEVEN SIX THREE TWO ONE THREE OF THE THREE  
EIGHT SQ AND THE FIVE FIVE GROUP PD SPARE FOR EXCELLENCE FROM CULLEN SIGNED  
WALSH TOPSEC TAKE ONE SEVEN SEVEN PD THESE AIRPLANE AND CREWS ARE BEING HELD  
HERE FOR FRANTIC SIX AS IS FIRST LIEUT DAVIS OF THE THREE FIVE SEVEN FIGHTER  
GROUP WHO HAS MADE FOUR FALSE DEPARTURES PD ALSO HELD IS FIRST LIEUT SHERIDAN  
OF THREE NINE ZERO BOLD OF OMA CREW AND AIRPLANE WHO TURNED BACK FROM TEHRAN  
FOR FRANTIC SIX  
YESTERDAY PD AIRPLANES AND CREWS WILL BE MADE OPERATIONAL



T-177

THE MAKING OF AN EXACT COPY OF THIS MESSAGE IS FORBIDDEN. ONLY  
SUCH EXTRACTS AS ARE ABSOLUTELY NECESSARY WILL BE MADE AND PROPERLY  
CLASSIFIED.

0582

HEADQUARTERS  
EASTERN COMMAND  
USSTAF  
OUTGOING MESSAGES

|                |                       |                       |
|----------------|-----------------------|-----------------------|
| PRECEDENCE     | URGENT                | P.T.CULLEN, COL, A.C. |
| CLASSIFICATION | <del>TOP SECRET</del> | ORIGINATOR            |
| DATE           | 13 AUGUST 1944        | APPROVED, ADJUTANT.   |
| SRL NR         | T171                  | TO: JJHL, JBPD        |

THIS RETURNED TO POLTVA AT ZERO NINE ZERO ZERO ZERRA PD [ ] EAKER  
FOR POLIFKA INFO TO SPATZ FROM CULLEN SIGNED WALSH TOP SECRET TARE  
ONE SEVEN ONE [ ] BIALYSTOK PROPOSED FOR ENGLISH SHUTTLES ~~TOP SECRET~~ ONLY  
REPEAT ONLY PD HIGHBALL SEVEN IS CLEARED DESIRED COVERAGE ON KRAKOW  
AIRDROME AND MARSHALLING YARD



THE MAKING OF AN EXACT COPY OF THIS MESSAGE IS FORBIDDEN. ONLY  
SUCH EXTRACTS AS ARE ABSOLUTELY NECESSARY WILL BE MADE AND PROPERLY  
CLASSIFIED.

0583

HEADQUARTERS  
EASTERN COMMAND  
USSTAF  
OUTGOING MESSAGES

PRECEDENCE  
CLASSIFICATION ~~SECRET~~

DEF CDR FOR OPS  
ORIGINATOR

DATE 13 AUGUST 1964

APPROVED, ADJUTANT.

SRL NR

TO: JBPD

T-173

CLEARANCE HAS BEEN FILED WITH DOWDITS FOR HIGHBALL FIVE PD PAREN SPATZ FOR DOOLITTLE  
FROM CULLER SIGNED WALSH CITE TARE ONE SEVEN THREE TWO SEC PAREN LET HIM COME

ANSWER TO 2462 (D-60454)



THE MAKING OF AN EXACT COPY OF THIS MESSAGE IS FORBIDDEN. ONLY  
SUCH EXTRACTS AS ARE ABSOLUTELY NECESSARY WILL BE MADE AND PROPERLY  
CLASSIFIED.

0584

HEADQUARTERS  
EASTERN COMMAND  
USSTAF  
OUTGOING MESSAGES

|                |         |                     |       |
|----------------|---------|---------------------|-------|
| PRECEDENCE     | _____   | ORIGINATOR          | _____ |
| CLASSIFICATION | _____   | APPROVED, ADJUTANT. | _____ |
| DATE           | _____   |                     |       |
| SRL NR         | _____   |                     |       |
|                | TO: JMW |                     |       |

ALL INFORMATION CONTAINED HEREIN IS UNCLASSIFIED  
DATE 08-08-2001 BY 60322 UCBAW/STP



THE MAKING OF AN EXACT COPY OF THIS MESSAGE IS FORBIDDEN. ONLY  
SUCH EXTRACTS AS ARE ABSOLUTELY NECESSARY WILL BE MADE AND PROPERLY  
CLASSIFIED.

0585

HEADQUARTERS  
EASTERN COMMAND  
USSTAF  
OUTGOING MESSAGES

|                |                |                       |
|----------------|----------------|-----------------------|
| PRECEDENCE     |                | ROSSER                |
| CLASSIFICATION | SECRET         | ORIGINATOR <i>WLS</i> |
| DATE           | 12 AUGUST      | APPROVED, ADJUTANT.   |
| SRL NR         | TO:            |                       |
| JK-1846        | MESSAGE CENTER |                       |

RELAY MESSAGE TO MOSCOW. SER NO. U66204. XMF MCR 119 AUGUST 11.

*2396- Dalk Project - Sparta evidence  
Auburnville report to Hqs. Dept.*



THE MAKING OF AN EXACT COPY OF THIS MESSAGE IS FORBIDDEN. ONLY SUCH EXTRACTS AS ARE ABSOLUTELY NECESSARY WILL BE MADE AND PROPERLY CLASSIFIED.

0 5 8 6

HEADQUARTERS  
EASTERN COMMAND  
USSTAF  
OUTGOING MESSAGES

|                |                            |                      |
|----------------|----------------------------|----------------------|
| PRECEDENCE     | OP PRIORITY                | DEPUTY COMDR FOR OPS |
| CLASSIFICATION | <del>SECRET</del><br>CLEAR | ORIGINATOR           |
| DATE 11 Aug 44 |                            | APPROVED, ADJUTANT.  |
| SRL NR         | TO: Message Center         |                      |
| T 146          |                            |                      |

Request relay of UX 66238 (Red # 2375) to Deane for Walsh

(FRANTIC 6 PLANS)



THE MAKING OF AN EXACT COPY OF THIS MESSAGE IS FORBIDDEN. ONLY SUCH EXTRACTS AS ARE ABSOLUTELY NECESSARY WILL BE MADE AND PROPERLY CLASSIFIED.

7 4 7 0  
0 5 8 7

PARAPHRASE

OP PRIORITY ~~SECRET~~  
TO: SPAATZ AND DEANE

11 AUGUST 1944  
DEP CMDR FOR OPS

T 145 JBPD JMRR

EASTERN COMMAND IS ABLE TO SERVICE FIVE MISSIONS, ASSUMING THAT FRANTIC 6 IS COMPOSED OF 70 B-17'S AND 70 MUSTANGS, AND PROVIDING THAT 75 MUSTANG 108 DROP TANKS ARE SENT PRIOR TO THE FOURTH MISSION HERE. FRANTIC 6 SHOULD LAST FROM 10 TO 7 DAYS, DEPENDING ON METEOROLOGICAL CONDITIONS. WE HAVE IN MIND SUFFICIENT TARGETS FOR THESE MISSIONS. NEW COVERAGE BY PHOTO OF KRAKOW HAS BEEN REQUESTED BY THE RUSSIANS, WHICH WAS OBTAINED ON 10 AUGUST. IT REVEALED 3 TO 4 GOOD TARGETS. TWO ARE A/C REPAIR FACILITIES, TWO ARE MARSHALLING YARDS. PHOTOS HAVE BEEN DESPATCHED TO MOSCOW FOR DESIGNATION OF TARGETS RUSSIANS DESIRE TO BE HIT. SOVIETS WERE TOLD OF FRANTIC 6 ~~PLAN~~ ON 9 AUGUST, PLAN TO HIT JEASU AIRFIELD NEAR KOENIGSBERG ON 10 AUGUST. THEY EXPRESSED DISAPPOINTMENT WHEN PLAN WAS NOT REALIZED. NO DIFFICULTIES ARE ANTICIPATED IN GETTING OK FOR ANY TASK FORCE'S FLIGHT PLAN. PROVIDED PHOTO RECON SHUTTLE MISSIONS WILL BE OK'D PROVIDED THEY ARE NOT CONSTANTLY POSTPONED AND ALSO THAT ALL ENTER THRU THE SAME POINT. BIALYSTOCK IS RECOMMENDED.

WALSH

RELAYED TO JCCG -  
15 AUG (T-145)



T-145

0 4 7 7  
0 5 8 8



HEADQUARTERS  
EASTERN COMMAND  
USSTAF  
OUTGOING MESSAGES

|                   |          |                     |
|-------------------|----------|---------------------|
| PRECEDENCE        | PRIORITY | _____               |
| CLASSIFICATION    | SECRET   | _____               |
| DATE 11 AUGUST    |          | ORIGINATOR          |
|                   |          | APPROVED, ADJUTANT. |
| SRL NR<br>JK-1822 | TO:      | JRFD                |

ALL OF YOUR ORIGINAL ORDERS BEING IMPLICITLY COMPLIED WITH WITHOUT EXCEPTION PD PAREN  
TO SPAATZ FOR MC DONALD SIGNED O'HARA TOP SEC JIG KING ONE EIGHT TWO TWO P HEN THE  
MOVE OF AMERICAN MEMBERS TO POLTAVA WAS IN NO WAY AN ATTEMPT TO SEPARATE THE PARTY  
BUT WAS CONSIDERED THE ONLY ~~XXXXX~~ POSSIBLE MEANS TO ADVANCE THE VISA SITUATION PD  
IT HAS MADE POSSIBLE THE ASSEMBLING OF FOOD SUPPLIES, <sup>CMP</sup> TOOLS AND TEST EQUIPMENT FOR  
THE WHOLE PARTY PD THIS MOVE MADE ONLY AFTER CONFERENCE WITH AND APPROVAL OF HEADS OF  
THE BRITISH CONTINGENT COL SANDERS AND COL MERRIMAN PARA UNDERSTAND BRITISH VISAS NOW  
SIGNED PD MEETING WITH LOCAL RUSSIANS TODAY INDICATES OURS WILL BE SIGNED BY  
TONIGHT PD GENERAL WALSH AND AIR COMMODORE ROBERTS HAVE WORKED CONTINUOUSLY TO SECURE  
THE NECESSARY SANCTIONS FOR THE COMBINED PARTY TO EXAMINE THE DESIRED AREAS WHICH ARE  
BEING ROPED OFF AND DEMARKED BY THE RUSSIANS WITH THE UNDERSTANDING OUR PARTY  
WILL BE THE FIRST TO COME THE AREA SPECIALLY SET ASIDE PARA COL SANDERS OF BRITISH  
PARTY ON 18 AUGUST TO URGE MORE SPEED IN OPENING SITES TO PARTY AND BE STAND READY  
WITH OUR PLANS TO COLLECT ENTIRE PARTY THE INUTE PERMISSION TO MOVE FORWARD HAS BEEN  
GRANTED BY THE RUSSIANS



THE MAKING OF AN EXACT COPY OF THIS MESSAGE IS FORBIDDEN. ONLY  
SUCH EXTRACTS AS ARE ABSOLUTELY NECESSARY WILL BE MADE AND PROPERLY  
CLASSIFIED.

4 7 8  
0 5 8 9

HEADQUARTERS  
EASTERN COMMAND  
USSTAF  
OUTGOING MESSAGES

|                |                       |                                 |
|----------------|-----------------------|---------------------------------|
| PRECEDENCE     | URGENT                | P. T. CULLEN, COL., A.C.        |
| CLASSIFICATION | SEE <del>SECRET</del> | DEPUTY CO FOR OPS<br>ORIGINATOR |
| DATE           | AUG 11                | APPROVED, ADJUTANT.             |
| SRL NR         |                       |                                 |
| T-138          | TO: JJHL              |                                 |

DAILY CLEARANCES ARE SUBMITTED ~~MESSAGE~~ TO SOVIETS FOR TWO LIGHTNING TO CROSS IN AT  
JANOSLAV AT ZERO EIGHT THREE ZERO PD BAKER FOR POLIFKA FROM CULLEN SGT WALSH TOPSEC  
TARE ONE THREE EIGHT PD THIS TIME CAN BE CHANGED IF UNSATISFACTORY TO YOU PD WILL  
CONTINUE TO FILE CLEARANCES BUT DESIRE TO HAVE HIGHBALL NUMBER AND ACTUAL DEPARTURE  
NOTICE PD CLEARANCES ARE ALSO FILED FOR JASSY AT ZERO NINE THIRTY EACH DAY PD ASSURE  
DAILY FLIGHTS AND SUSPEND FOUR EIGHT HOUR NOTICE PD AN INCREASE IN SHUTTLE WILL  
STRENGTHEN OUR POSITION

*anewies PWA 824-C (2307)*



THE MAKING OF AN EXACT COPY OF THIS MESSAGE IS FORBIDDEN. ONLY  
SUCH EXTRACTS AS ARE ABSOLUTELY NECESSARY WILL BE MADE AND PROPERLY  
~~CLASSIFIED.~~

487  
0590

PARAPHRASE

ROUTINE ~~TOP SECRET~~

10 AUGUST  
KESSLER

TO: DEANE  
JK 1817 JMRR

ABOUT KNERR PARTY NO FURTHER NEWS. OMARA PARTY IS BEING HELD AWAITING INSTRUCTIONS FROM YOU. FRANTIC 6 IS POSTPONED INDEFINITELY, WITH NO REASONS GIVEN. SHOWN TONIGHT WAS THE MOVIE "MISSIONS FOR MOSCOW", RUSSIANS WERE ENTHUSIASTIC. 15 AF B-24 RETURNED TO POLTAVA TONIGHT FROM LWOW. SO WERE X 2 PARACHUTISTS FROM FRANTIC 5. ALL WERE TREATED VERY WELL BY THE SOVIETS. THEY WILL BE RETURNED BY ATC TO HOME STATIONS. SHALL WE DETAIN POLISH EVACUEES? ALSOP AND PEMBERTON ARE DEPARTING TOMORROW FOR TEHRAN WELL SATISFIED WITH VISIT AND LOCAL CONDITIONS. PROGRESSING SATISFACTORY IS RECOVERY OF A/C FORCED DOWN ~~SM~~ BEFORE REACHING THE BASES.

KESSLER SIGNED WALSH



~~TOP SECRET~~  
JK-1817

0591

HEADQUARTERS  
EASTERN COMMAND  
USSTAF  
OUTGOING MESSAGES

|            |                |                     |
|------------|----------------|---------------------|
| PRECEDENCE | CLASSIFICATION | COL MURDELL         |
|            | SECRET         | ORIGINATOR          |
| DATE       | 10 AUGUST 44   | APPROVED, AUTHORITY |
| SRL NR     | TO:            | JEPD                |
| 3K 1514    |                |                     |

CLARK GARA ROCKET INVESTIGATING PARTY AT POLTAVA AWAITING  
SOLUTION OF VISA DIFFICULTY PD PAREN SPATZ FROM KOSLER  
SIGNED WALSH CITE JIG KING [1814] TOP SECRET PAREN  
WE ARE AWAITING INSTRUCTIONS FROM MOSCOW PD USED R TAND BRITISH  
MEMBERS HAVE BEEN CLEARED FROM TIRANAN WITH DESTINATION EITHER  
POLTVA OR MOSCOW PD APPARENTLY SOVIET ARE NOT IN A POSITION TO  
TAKE THEM TO THE SITE

ANSWER TO 2344 (UX 66186)

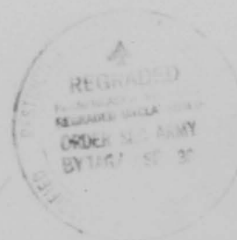

THE MAKING OF AN EXACT COPY OF THIS MESSAGE IS FORBIDDEN. ONLY  
SUCH EXTRACTS AS ARE ABSOLUTELY NECESSARY WILL BE MADE AND PROPERLY  
CLASSIFIED.

0592

HEADQUARTERS  
EASTERN COMMAND  
USSTAF  
OUTGOING MESSAGES

T-CIM/JD

|                |                                  |                     |
|----------------|----------------------------------|---------------------|
| PRECEDENCE     | URGENT                           | OPERATIONS          |
| CLASSIFICATION | <del>TOP SECRET</del>            | ORIGINATOR          |
| DATE           | 9 AUGUST 1944                    | APPROVED, ADJUTANT. |
| SRL NR         | TO: JHL JJC 9 <del>(PUNIC)</del> |                     |
| T/21           |                                  |                     |

LIEUTENANT CHARLES WILLIAM ELBERTY, FLYING LIGHTNING  
THREE TWO EIGHT SIX FIVE THREE WHO IS ONLY THREE ZERO SIX  
RING PILOT AT EASTERN COMMAND LEAVES FOR ITALY AUGUST TEN  
PD ALSO SENDING LIGHTNING SEVEN TWO ONE TO YOU PD ESCORTED  
BY EIGHTH AIR FORCE MUSTANG EIGHT ONE SEVEN WHO ABORTED  
THIS MORNING PD PAREN TO EAKER FOR TWINING FOR STROTHER  
INFORMATION SPAATZ FROM CULLEN SIGNED WALSH TOP SECRET  
TARE ONE TWO ONE PAREN FOLLOWING AIRCRAFT BEING REPAIRED  
AT THIS STATION CLN SIX SEVEN THREE OMA SEVEN ONE FIVE OMA  
NINE FIVE ZERO AND ONE SIX TWO PD THERE ARE THREE TO FOUR STILL  
ELSEWHERE IN SOVIET TERRITORY WHICH WILL SOON BE BROUGHT HERE  
AND THEN NUMBERS WILL BE SENT YOU

~~TOP SECRET~~

THE MAKING OF AN EXACT COPY OF THIS MESSAGE IS FORBIDDEN. ONLY  
SUCH EXTRACTS AS ARE ABSOLUTELY NECESSARY WILL BE MADE AND PROPERLY  
CLASSIFIED.

7 4 8 2  
0 5 9 3  
1 2 0 4

PARAPHRASE

~~T~~ SECRET ROUTINE

TO: DEANE  
T 117

JMRR

9 AUGUST  
KESSLER

HIGHLY SUCCESSFUL WAS THE MISSION YESTERDAY TO ITALY. BOMBING RESULTS GOOD. LOSSES NONE. 13 P-51 AND 3 P-38 THIS MORNING AIRBORNE FOR ITALY.

KESSLER SIGNED WALSH.

~~T~~

T-117

0594

HEADQUARTERS  
EASTERN COMMAND  
USSTAF  
OUTGOING MESSAGES

|                |  |                        |
|----------------|--|------------------------|
| PRECEDENCE     | URGENT                                       | P.T. CULLEN, COL, A.C. |
| CLASSIFICATION | TOP SECRET                                   | ONISTAYOR              |
| DATE           | 9 AUGUST 1944                                | APPROVED, ASJUTANT.    |
| SRL NR         | TO: JJHL, JJCQ (BOUNCE), JBPD, JBAF (BOUNCE) |                        |

OVER THE HUMP TO ITALIAN BASES ARE GOING PRN EAKER CMA TWINING CMA  
SPAATZ AND DOOLITTLE FROM WALSH TOP SECRET URGENT ONE THREE MUSTANGS  
AND THREE LIGHTNINGS AT ZERO FIVE FOUR EIGHT ZEBRA TOOK OFF



THE MAKING OF AN EXACT COPY OF THIS MESSAGE IS FORBIDDEN. ONLY  
SUCH EXTRACTS AS ARE ABSOLUTELY NECESSARY WILL BE MADE AND PROPERLY  
CLASSIFIED.

0595



HEADQUARTERS  
EASTERN COMMAND  
USSTAF  
OUTGOING MESSAGES

PRECEDENCE URGENT  
CLASSIFICATION ~~SECRET~~

DEPUTY CHIEF FOR OPS

0111111111

DATE 8 AUG 44

APPROVED, [Signature]

SRL NR  
T 108

TO: JJH.

CLEARANCE WITH TAKER FOR POLIFEA TOPSUG TARD ONE ZERO EIGHT PAREN  
FOR HIRBALL OIK HAS BEEN SUBMITTED TO WASHINGTON TO BE PROMPT  
DISAPPROVED YOU WILL BE ADVISED



THE MAKING OF AN EXACT COPY OF THIS MESSAGE IS FORBIDDEN. ONLY  
SUCH EXTRACTS AS ARE ABSOLUTELY NECESSARY WILL BE MADE AND PROPERLY  
CLASSIFIED.

0596

PARAPHRASE

8 AUGUST 1944  
KESSLER

ROUTINE ~~TOP SECRET~~

TO: SPAATZ AND DOOLITTLE INFO DEANE  
T 106

JBPD, JJHL, JMPR

74 FORTRESSES AND 64 MUSTANGS ARRIVED AT EASTERN COMMAND. 72 FORTRESSES AND 67 MUSTANGS AIRBORNE FOR ITALY THIS MORNING. MISSION ON REFINERY IN DREZBINIA YESTERDAY HIGHLY SUCCESSFUL APPARENTLY. NO A/C LOSSES. 1 GUNNER KILLED BY AA FIRE. RECOMMEND THAT ON OR ABOUT 12 AUGUST FORCE OF ABOUT THE SAME COMPOSITION AND NUMBER BE SENT. DISPATCH OF FIGHTER-BOMBER FORCE IS NOT RECOMMENDED SINCE PROFITABLE TARGETS SINCE FROM OUR EXISTING BASES PROFITABLE TARGETS ARE NOT AVAILABLE. STRAFING ATTACKS ARE MADE TOO COSTLY BY BATTLE DAMAGE AND LOSSES.

KESSLER SIGNED WALSH



0597

PARAPHRASE

URGENT ~~SECRET~~

8 AUGUST 1944  
COL P T CULLEN

TO: EAKER AND TWINING, INFO SPAATZ, DOOLITTLE, DEANE  
T 100

73 FORTERSSES AT 0515 ZEBRA AND 63 MUSTANGS AT 0600 ZEBRA DEPARTED  
FOR FOGGIA BASES SUCCESSFULLY.



HEADQUARTERS  
EASTERN COMMAND  
USSTAF  
OUTGOING MESSAGES

|                |                         |                         |
|----------------|-------------------------|-------------------------|
| PRECEDENCE     | URGENT                  | Lt Fischer Duty Officer |
| CLASSIFICATION | SEC                     | ORIGINATOR              |
| DATE           | 7 August 1944           | APPROVED, ADJUTANT:     |
| SRL NR         | TO: Signal Duty Officer |                         |

Query JMB to Deane for which whether WAR 7562A has been received there.

*Expansion - Movement of Personnel*



*QUERY*

THE MAKING OF AN EXACT COPY OF THIS MESSAGE IS FORBIDDEN. ONLY SUCH EXTRACTS AS ARE ABSOLUTELY NECESSARY WILL BE MADE AND PROPERLY CLASSIFIED.

7480  
0599

HEADQUARTERS  
EASTERN COMMAND  
USSTAF  
OUTGOING MESSAGES

|                 |                         |                     |
|-----------------|-------------------------|---------------------|
| PRECEDENCE      | [REDACTED]              | Lt Fischer          |
| CLASSIFICATION  | [REDACTED]              | ORIGINATOR          |
| DATE            |                         | APPROVED, ADJUTANT. |
| SRL NR<br>RELAY | TO: Signal Duty Officer |                     |

Relay U 66030 and U 66032 to AIRR (Moscow)

*Signal Duty Officer*  
*Shawto. to Berlin*

RELAY



THE MAKING OF AN EXACT COPY OF THIS MESSAGE IS FORBIDDEN. ONLY SUCH EXTRACTS AS ARE ABSOLUTELY NECESSARY WILL BE MADE AND PROPERLY CLASSIFIED.

0600

HEADQUARTERS  
EASTERN COMMAND  
USBTAF  
OUTGOING MESSAGES

|                |            |                     |
|----------------|------------|---------------------|
| PRECEDENCE     | URGENT     | DEF. CODE FOR CDS   |
| CLASSIFICATION | SECRET     | ORIGINATOR          |
| DATE           |            | APPROVED, AUTHORITY |
| SRL NR         | TO:        |                     |
| 193            | JHH<br>JJC | 1350                |

PARITY FIVE HITTING ELIZABETH AND B BAW AT ZERO SEVEN ZERO ZERO ZEBRA PD  
FOUR FOUR ZERO FIVE NORTH TWO SIX TWO ZERO EAST AT ZERO EIGHT FOUR TWO  
ALPHA DASH POLAR DASH TO FOUR THREE FIVE TWO NORTH TWO TWO FIVE ZERO  
EAST AT ZERO NINE THREE FIVE ZEBRA DASH FOUR TWO TWO NINE NORTH ONE EIGHT  
TWO TWO EAST PD REFERENCE CHARLIE SUGAR ONE ONE - VEE THREE COLON  
ABOVE FLIGHT PLAN ALSO IN COORDINATION WITH SOVIETS ON TARGETS SELECTED PER  
INSTRUCTIONS R C IV. THIS DATE EARLY FROM SPAATZ TO REPHRASE TARGETS  
HELPFUL TO HIS LANS <sup>PAREN</sup> ~~FOR~~ BAKER AND TALKING FROM HIS HER NIGHT WALSH  
TAM NINTHOUR PAREN V

↓  
INFO SPAATZ



THE MAKING OF AN EXACT COPY OF THIS MESSAGE IS FORBIDDEN. ONLY  
SUCH EXTRACTS AS ARE ABSOLUTELY NECESSARY WILL BE MADE AND PROPERLY  
CLASSIFIED.

0601

C. L. P. T. CULLEN

INTELLIGENCE

ROUTINE  
~~TOP SECRET~~

7 AUGUST

JEPD  
JJHL

INTERROGATION OF AMERICAN CREWS EVADING THROUGH POLAND [PARTIAL TOP SECRET TO SPAATZ  
AND HAKER SIGNED WALSH JIG KING \_\_\_\_\_] PARTIAL TO  
RUSSIA REVEALS FINE ASSISTANCE FROM POLISH PARTISANS AND INDICATES ANY AMERICAN  
HAS GOOD CHANCES TO MAKE CONTACT WITH THE PARTISANS PD SUGGEST ESCAPE AND EVASION  
BRIEFING EMPHASIZE DESIRABILITY OF BEING PICKED UP BY PARTISANS IN POLAND AND  
SUGGEST ANY ONE REASONABLY NEAR BORDER IN EASTERN GERMANY OR SLOVAKIA OR  
NORTHERN HUNGARY OR NORTHERN ROMANIA WORK TOWARD THAT OBJECTIVE PD MEN SHOULD  
NOT ATTEMPT TO CROSS GERMAN DASH RUSSIAN FRONTIER ALONE OR UNAIDED





HEADQUARTERS  
EASTERN COMMAND  
USSTAF  
OUTGOING MESSAGES

|                |        |
|----------------|--------|
| PRECEDENCE     | URGENT |
| CLASSIFICATION | SECRET |

P.T. CULLEN, COL, A.C.  
ORIGINATOR  
APPROVED, ASSISTANT.

DATE 7 AUGUST 1944

|                |                |
|----------------|----------------|
| SRL NR<br>T 92 | TO: JBPD, JJHL |
|----------------|----------------|

COMPLYING WITH SUGGESTION YOUR UNCLE XRAY SIX SIX ZERO THREE FOUR  
OIL MISSION ON TARGET GEORGE QUEEN ONE SIX FOUR SEVEN TODAY PD  
PAREN TOP SECRET SPAATZ FOR DOOLITTLE FOR PARTRIDGE INFO EAKER  
FROM KISSNER SIGNED WALSH TARE NINE TWO PAREN ~~PERVINDY~~ PRIMARY  
ATTACKED AT ONE ZERO ZERO ZERO ZEBRA WITH GOOD RESULTS WITH/SIXTY  
OF FORTRESSES AND THREE SIX MUSTANGS PD PLAN TO ATTACK WITH ALL  
AIRCRAFT TWO IMPORTANT AIRFIELDS CMA ~~HELPFUL~~ HELPFUL TO AND COORDINATED  
WITH SOVIETS ON AUGUST EIGHT PROCEEDING TO ITALY BASES PD IN VIEW  
OF INABILITY TO DEPLOY AT NIGHT AND RUN DAILY MISSIONS AND GIVING  
CONSIDERATION TO MAINTENANCE AND CREW FATIGUE RETURN SHUTTLE FROM  
ITALY BASES INADVISABLE PD WALSH CONCURS PD STRIKE PHOTOS SHOW  
EXCELLENT RESULTS ON TARGET ATTACKED SIX AUGUST



THE MAKING OF AN EXACT COPY OF THIS MESSAGE IS FORBIDDEN. ONLY  
SUCH EXTRACTS AS ARE ABSOLUTELY NECESSARY WILL BE MADE AND PROPERLY  
CLASSIFIED.

7 5 9 2  
0 6 0 3

HEADQUARTERS  
EASTERN COMMAND  
USSTAF  
OUTGOING MESSAGES

|                |          |
|----------------|----------|
| PRECEDENCE     | PRIORITY |
| CLASSIFICATION |          |

\_\_\_\_\_ KESSLER \_\_\_\_\_

\_\_\_\_\_ ORIGINATOR \_\_\_\_\_

DATE 7 JUNE 1954

\_\_\_\_\_ APPROVED, ASJUTANT. \_\_\_\_\_

SRL NR  
JK 1735

TO: AFZA

SUGGEST SANDERS AND PARTY REMAIN AT THERAN UNIL CONTROVERSY IS SETTLED PD FARE  
TO CONSULE FOR PARTIS FROM KESSLER WOULD WALK INFO DEASE JIG KING AND VER  
THIR FIVE TOP SEC PAUL SOVIET VERY CONCERNED ABOUT ENTRY OF AMERICAN CONTINGENT  
US GROUP VIA PD AMBASSADOR AND WOULD CONSIDERING RETURN OF AMERICAN CONTINGENT TO  
THERAN PD STATE REQUESTED DESIRE TO HAVE STING UP AT ENTIRE PARTY BE HOLD INTACT  
PD WALKER NOW IN MOSCOW TO DISCUSS WITH AMBASSADOR PD INSTRUCTION WILL ISSUE FROM  
THERAN



PX 17394

THE MAKING OF AN EXACT COPY OF THIS MESSAGE IS FORBIDDEN. ONLY  
SUCH EXTRACTS AS ARE ABSOLUTELY NECESSARY WILL BE MADE AND PROPERLY  
CLASSIFIED.

0604

HEADQUARTERS  
EASTERN COMMAND  
USSTAF  
OUTGOING MESSAGES

|                    |                         |                        |
|--------------------|-------------------------|------------------------|
| PRECEDENCE         | OPS PRIORITY            | P.T. CULLEN, COL, A.C. |
| CLASSIFICATION     | <del>SECRET</del>       | ORIGINATOR             |
| DATE 7 AUGUST 1944 |                         | APPROVED, ASSIGNED     |
| SRL NR<br>T87      | TO: JBPD, JBAF (BOUNCE) |                        |

AIRBORNE ARE FIVE FIVE FORTRESSES AND THREE NINE MUSTANGS FROM FRANTIC  
FIVE PAREN SPAATZ AND DOOLITTLE FROM WALSH TOP SECRET TARE EIGHT SEVEN  
PAREN ~~AVEFACE FIVE~~ MISSION



THE MAKING OF AN EXACT COPY OF THIS MESSAGE IS FORBIDDEN. ONLY  
SUCH EXTRACTS AS ARE ABSOLUTELY NECESSARY WILL BE MADE AND PROPERLY  
CLASSIFIED.

0605

SECRET  
ROUTINE

GEN WALSH

6 August 1944

USSTAF

DURING CONFERENCE WITH PERMINOV TODAY SUBJECT OF PHOTO RECONNAISSANCE CLEARANCES TO THE NORTHWEST DISCUSSED PD THESE HAVE BEEN CONSISTENTLY REFUSED PD HE STATED THAT REASONS FOR REFUSAL WERE PROBABLY TWOFOLD PD FIRST ~~XXXX~~ NUMBER OF CLEARANCES WE REQUESTED CMA SOME OF THEM WITH ONLY POSSIBILITY OF GOOD WEATHER AND CHANGES IN NUMBER OF PLANES BOTH WITH REGARD TO PWY OPERATIONS CMA STRADCLERS RETURNING DIRECT TO ITALY AND BOMBING MISSION OPERATIONS, AND THE CHANGES WE CONSTANTLY MADE LEAD TO A GREAT DEAL OF CONFUSION PD PAREN TO SPEAK FROM WALSH

PAREN HE ALSO STATED THAT NORTHWEST WAS VERY ACTIVE FRONT NOW AND SOVIETS DID NOT WANT TO PUT ANY FURTHER BURDEN ON THEIR ALREADY OVERTAXED COMMUNICATIONS IN NORTHWEST AREA PD THEREFORE THERE EXISTED DIFFICULTY OF GIVING SECURITY TO FLIGHT. PD PERMINOV ALSO STATED THIS GAVE HIM OPPORTUNITY TO BRING UP DEFICIENCIES IN OUR CLEARANCES PD SOVIET MANNER OF CONDUCTING BATTLE REQUIRES THAT REQUESTS GO TO MOSCOW AND BACK OUT BY TELEPHONE TO SMALL SCHEDULES ON FRONT PD EACH FLIGHT PLAN AND EACH CHANGE REQUIRES TENDENTIOUS STAFF WORK TO GET INFORMATION TO INDIVIDUAL BATTERY PD AS PREVIOUSLY STATED SOVIETS REQUIRE THAT FOLLOWING INFORMATION BE IN THEIR HANDS TWENTY FOUR HOURS BEFORE FLIGHTS COLON PLACE CMA ALTITUDE CMA TIME OF CROSSING FRONT CMA TIME AT BASES AND GENERAL ROUTE PD WITH REFERENCE TO TARGET INFORMATION I EM STATED THIS WAS WITHHELD PRIMARILY FOR SECURITY REASONS AND PERMINOV UNDERSTOOD PD FLIGHT PLANS FROM EIGHTH

JK-1729

PAGE ONE OF 2 Pages

0606

ROUTINE  
SECRET

GEN WALSH

USSTAF (PAGE 2 of 2 Pages.

AND FIFTEENTH HAVE OMITTED ONE OR MORE OF THESE REQUIREMENTS PD RECOMMEND THAT POINT  
AND TIME OF CROSSING FRONT AND TIME AT POLTAVA BE DETERMINED EARLY AND THAT  
TAKEOFF TIMES OR TARGETS BE ADJUSTED TO MEET PD IMPRESSION IS GAINED THAT  
SMALL CHANGES IN TIME DO NOT REPEAT NOT AFFECT THEM AS MUCH AS CHANGE OF ROUTE  
AND POINT OF CROSSING PD NEW SUBJECT PERMINOV HAS BEEN INFORMED OF OUR SPECIAL  
EFFORTS TO ATTACK TARGETS IN HUMANIA AREA AND PRESUME SOVIETS HOPE THIS WILL  
HAVE A DIVERSIONARY EFFECT ON GERMAN AIR FORCES ORA FORCING WITHDRAWAL FROM  
THEIR OTHER FRONTS PD RECENT INFORMATION INDICATES THAT COUNTRY AIR FORCE  
TARGETS THERE ARE NOW NOT REPEAT NOT ESPECIALLY PROFITABLE PD HOWEVER SOVIETS  
STATE SEVERAL RECENT VERY DAMAGING ATTACKS TO THEM HAVE COME FROM THAT  
AREA AND OUR CONCENTRATION OF EFFORT THERE MAY HAVE SOME EFFECT

JK-1729

0607

HEADQUARTERS  
EASTERN COMMAND  
USCJAF  
OUTGOING MESSAGES

|                |              |                      |
|----------------|--------------|----------------------|
| PRECEDENCE     | URGENT       | DEPUTY COMDR FOR OPS |
| CLASSIFICATION | SECRET       | ORIGINATOR           |
| DATE           | 6 AUG 44     | APPROVED, ASSJYANT.  |
| SRL NR         |              |                      |
| T 32           | TO: JBPD JML |                      |

FRANTIC FIVE FOR AUGUST SEVEN PRIMARY IS GEORGE QUEEN ONE, SIX FOUR  
SEVEN PD SPATZ AND EAKER FROM WALSH TOPSEC TAKE EIGHT TWO PD  
SECONDARY IS GEORGE QUEEN FIVE SIX ONE TWO PD TARGET TIME IS ONE  
ZERO ZERO ZERO X ZEBRA PD RETURNING TO EASTERN COMMAND



THE MAKING OF AN EXACT COPY OF THIS MESSAGE IS FORBIDDEN. ONLY  
SUCH EXTRACTS AS ARE ABSOLUTELY NECESSARY WILL BE MADE AND PROPERLY  
CLASSIFIED.

0608

URGENT  
SECRET

GEN WALSH

6 AUGUST 1944

USSTAF

RADIO FROM MOSCOW INDICATES SOVIETS RESIST OMARA PARTY ENTERING ON  
GROUP VISA AND STATES OMARA REMAINING POLTAVA MAY COMPLICATE OBTAINING  
OBJECTIVE PD ALSO UNDERSTAND THAT PROJECTED INVESTIGATION IS NOT TO BE  
APPROVED UNTIL AREA DEFINITELY IN RED HANDS CMA NEEDS LOCATE ESTABLISHMENT  
CMA AND AREA IS DETERMINED PD BAKEN TO SPAATE FROM WALSH

PARER LEAVING FOR MOSCOW TOMORROW AND POSSIBLE PROPOSAL  
WILL BE TO RETURN OMARA PARTY TO TEHRAN AND THEY AWAIT REGULAR VISAS  
THESE PD BRITISH NOW INSTRUCTED TO AWAIT TEHRAN UNTIL PROJECT APPROVED  
PD WILL TALK TO HARRIMAN AND IF ANY SPECIAL INSTRUCTIONS REQUEST YOU  
RADIO DIRECT MOSCOW TO AVOID DELAY

UNGRADED

ARMY  
BY/

JK 1721

0609



HEADQUARTERS  
EASTERN COMMAND  
USCIB  
OUTGOING MESSAGES

|                |          |                      |
|----------------|----------|----------------------|
| PRECEDENCE     | URGENT   | DEPUTY COMDR FOR OPS |
| CLASSIFICATION | SECRET   | ORIGINATOR           |
| DATE           | 6 AUG 44 | APPROVED, ASSYATT.   |
| SRL NR         | TO: JHHL |                      |
| T B1           |          |                      |

FRANTIC FIVE HITS REFINERIES AT ONE ZERO ZERO ZERO ZEBRA AUGUST  
SEVEN PD EAKER FOR POLIFKA FROM WALSH TOPSEC TARE EIGHT ONE PD  
WAAF NUMBERS ONE SIX DASH SIX DASH NA AND ONE SIX DASH THREE DASH  
NA PD RMXRY ACKNOWLEDGE PD QUERY CAN YOU SECURE ASSESSMENT  
PHOTOGRAPHS EITHER ON SHUTTLE OR FROM ITALY



THE MAKING OF AN EXACT COPY OF THIS MESSAGE IS FORBIDDEN. ONLY  
SUCH EXTRACTS AS ARE ABSOLUTELY NECESSARY WILL BE MADE AND PROPERLY  
CLASSIFIED.

0610

ROUTINE  
~~SECRET~~ SECRET

GEN WALSH

6 August 1944

WD

HAVE SENT SPAATE RADIO REFERENCE BALL HEARING PROJECT PD HAVE RECEIVED NO  
 WORD OF SOVIET APPROVAL THE PROJECT PAREN TO OPERATIONS DIVISION ATTN  
 COL CHAFFEE FOR DELIVERY TO GEN DEANE PAREN  
 INFORMAL TALK WITH LEVANDOVICH GAVE ME IMPRESSION SOVIETS WAITING FOR  
 PROGRESS OF FRONT SO AS TO ELIMINATE NECESSITY CROSSING FRONT LINE AND  
 INTO THEIR TERRITORY AT NIGHT PD HAVE HAD NO RESULTS FROM TALK WITH  
 ANTONOV PAR AGAIN PUSHING FOR DECISION ON NIGHT FIGHTER AND EXPANSION  
 PROGRAM BUT AS YET NO INFORMATION WHATSOEVER FROM SOVIETS ON THIS SUBJECT  
 NOR WILL ANYONE TALK PD WIRE FROM SPAATE INDICATES DEADLINE IS ONE FOUR  
 AUGUST AND SPECIAL REQUEST IS BEING MADE FOR DECISION PRIOR TO THAT DATE  
 PD MESSAGE ALSO SAYS THAT IF DECISION NOT REACHED PRIOR TO ONE FOUR THAT  
 IT WILL POSTPONE PROJECT FOR AT LEAST THIRTY DAYS

AKS TO: 2180 (M20447) 3/6

JK 1715



0611

Routine  
~~SECRET~~

GEN WALSH

6 August 1944

USSTAF

PRESENT INDICATIONS REFERENCE YOUR UNCLE SIX FIVE FOUR THREE SEVEN ARE  
THAT FIRST INFO REFERENCE ADVANCE OF RUSSIAN FRONT COMES FROM GERMAN  
BROADCAST ONA NEXT COMES FROM ESCOM AND NEXT FROM PBO AND USMILMIS  
PD DOES THIS CHECK WITH YOUR RECORDS PAREN FOR SPAAZE <sup>info Collier</sup> FROM WALSH

PAREN THIS INDICATES DANGER OF ESTABLISHING BOMB  
LINE TOO CLOSE TO FRONT AND NEED FOR CLEARING INDIVIDUAL TARGETS AS  
YOU ARE NOW DOING PD APPARENTLY RUSSIANS DO NOT ANNOUNCE THEIR GAINS  
UNTIL THEY ARE POSITIVE THEY ARE GOING TO ~~XXXXXXXXXX~~ HOLD GROUND AND  
FOR THAT REASON SOME OF THEIR ADVANCES ARE PROBABLY <sup>at least</sup> TWO FOUR HOURS  
AHEAD OF INFORMATION GIVEN OUT

REFERS TO: 1179 (U65437)-7/26



0612

ROUTINE

Gen Walsh

~~SECRET~~

6 August 1944

USSTAF

AT MEETING WITH GEN LEVANDOVICH IN MOSCOW TECHNICALITIES REFERENCE DOLLY  
PROJECT DISCUSSED PAREN FOR SPAATZ FROM WALSH PAREN  
BELIEVE POSSIBLY SOVIETS WILL WITHHOLD APPROVAL FOR FLIGHTS IN ANTICIPATION  
OR HOPE ENEMY TERRITORY <sup>FRONT</sup> WILL BE ELIMINATED FROM AREA OF PROPOSED CROSSING  
MAKING NIGHT FLIGHTS UNNECESSARY PD THIS SENT FOR YOUR INFO ONLY AS  
NO COMMITMENT OR SPECIAL INDICATION TO THIS EFFECT BUT ONLY IMPRESSION  
GATHERED FROM GENERAL CONVERSATION



0613

HEADQUARTERS  
EASTERN COMMAND  
USSTAF  
OUTGOING MESSAGES

P. I. CULLEN, COL., A.C.

PRECEDENCE ~~URGENT~~  
CLASSIFICATION ~~SECRET~~  
DATE 6 AUGUST 1944

INITIATOR  
APPROVED, ASJUTANT.

TEL NR TO: JJHL, JJCC (BOUNCE), JMRR, JRPD

WINGING TO FOGGIA FROM ESCOM ARE TWO NINE EIGHT NINE AND TWO NINE  
MUSTANGS [ PD PAREN TO EAKER CMA TWING CMA DEANE AND SPAATZ TOP  
SECRET FROM WALSH TARE SIX TWO PAREN ] AT ZERO SIX THREE ZERO ZEBRA  
THEY WERE AWAY



THE MAKING OF AN EXACT COPY OF THIS MESSAGE IS FORBIDDEN. ONLY  
SUCH EXTRACTS AS ARE ABSOLUTELY NECESSARY WILL BE MADE AND PROPERLY  
CLASSIFIED.

0614

HEADQUARTERS  
EASTERN COMMAND  
USSTAF  
OUTGOING MESSAGES

|                |                   |                      |
|----------------|-------------------|----------------------|
| PRECEDENCE     | URGENT            | DEPUTY COMDR FOR OPS |
| CLASSIFICATION | <del>SECRET</del> | ORIGINATOR           |
| DATE           | 5 AUG 1944        | APPROVED, ADJUTANT.  |
| SRL NR         | TO: JJHL JSFD     |                      |
| T 57           |                   |                      |

CLEARANCE REQUESTED IN YOUR PWR SEVEN NINE NINE DASH CHARLIE  
SUBMITTED TO RUSSIANS [FD PAREN BAKER FOR POLIFKA INTO SPAATZ  
FROM WALSH TOPSEC TARK FIVE SEVEN PAREN] YOU WILL BE NOTIFIED  
IF FLIGHT IS REFUSED

ANS TO 2141 (PWR 799-C)



THE MAKING OF AN EXACT COPY OF THIS MESSAGE IS FORBIDDEN. ONLY  
SUCH EXTRACTS AS ARE ABSOLUTELY NECESSARY WILL BE MADE AND PROPERLY  
CLASSIFIED.

0615

1700 HEADQUARTERS  
 EASTERN COMMAND  
 USSTAF  
 OUTGOING MESSAGES

PRECEDENCE URGENT  
 CLASSIFICATION ~~SECRET~~

R. J. GILLEN  
 ORIGINATOR

DATE 5 AUGUST 44

APPROVED, ADJUTANT.

SRL NR  
 T 55

TO: JRPD JJHL

FRANTIC FIVE PLANS SUBMITTED TO SOVIETS PD SPAATZ AND DOOLITTLE  
 FROM WALSH TOPPED TARE FIVE FIVE PD LAND THREE SIX BAKER ONE SEVENS  
 AT FOLTAVA OMA THREE SIX BAKER ONE SEVENS AT MIRGOROD OMA SIX FIVE  
 PEPER FIVE ONES AT FRYATIN PD RUSSIAN RADIO FACILITIES IN ADDITION  
 TO THOSE LISTED IN SOP FOLLOW IN FROM ONE THREE ZERO ZERO ZBRA  
 TO ONE EIGHT ZERO ZERO ZBRA SEAGONS THREE OMA FIVE OMA SIX OMA  
 EIGHT OMA NINE OMA WILL OPERATE ~~PLANS~~ STAY ON PLANNING

ANS. TO: 2138 (U65931)



THE MAKING OF AN EXACT COPY OF THIS MESSAGE IS FORBIDDEN. ONLY  
 SUCH EXTRACTS AS ARE ABSOLUTELY NECESSARY WILL BE MADE AND PROPERLY  
 CLASSIFIED.

0616



HEADQUARTERS  
EASTERN COMMAND  
USSTAF  
OUTGOING MESSAGES

|                |          |          |                      |
|----------------|----------|----------|----------------------|
| PRECEDENCE     | URGENT   | OF       | DEPUTY COMDR FOR OPS |
| CLASSIFICATION | SECRET   |          | ORIGINATOR           |
| DATE           | 5 AUG 44 |          | APPROVED, ASSISTANT. |
| SRL NR         |          | TO: JJIL |                      |
| T 5A           |          |          |                      |

GLIDED IN TO ESCON BEFORE ZERO FOUR THREE EIGHT ZEBRA TWO  
 FORTRESSES [FD] BAKER FOR TWINING FROM WALSH TOPSEC TARE FIVE FOUR PD  
 BY XME TARE TWO NINE THIS INFORMATION ON FOUR AUGUST SENT YOUR WAY

ANSWER TO: 2136 (W 57 IE)



THE MAKING OF AN EXACT COPY OF THIS MESSAGE IS FORBIDDEN. ONLY  
 SUCH EXTRACTS AS ARE ABSOLUTELY NECESSARY WILL BE MADE AND PROPERLY  
 CLASSIFIED.

0617

HEADQUARTERS  
EASTERN COMMAND  
USSTAF  
OUTGOING MESSAGES

|                |                   |                      |
|----------------|-------------------|----------------------|
| PRECEDENCE     | GP PRIORITY       | DEPUTY CHIEF FOR OPS |
| CLASSIFICATION | <del>SECRET</del> | ORIGINATOR           |
| DATE           | 5 August 1944     | APPROVED, AGENCY.    |
| TO: 58R        | JSPD J J H L      |                      |

AMPLE MUSTANG MECHANICS TO MAINTAIN EIGHTH AIR FORCE MUSTANGS  
 ARE AT FIRYATIN PD DO NOT REPEAT NOT SEND ADDITIONAL MECHANICS  
 PD SPANZ, FROM WALSH POPING TARE FIVE TWO PD SUPPLY SITUATION  
 GOOD EXCEPT THAT WE HAVE NO REPEAT NO ARMOR PIERCING INCENDIARY  
 FIFTY CALIBER ORA OTHER CATEGORIES ALRIGHT PD SENDING FORTY  
 LIGHTNING MECHANICS BACK TO ITALY AUGUST SEVEN PD YOUR UNCLE  
 SIX FIVE NINE TWO TWO IS ANSWERED

ANS TO: 2115 (U65922)

ANS BY: 2158 (UX 65960)

REFER TO: 2155 (UX 65989) - SECRET



THE MAKING OF AN EXACT COPY OF THIS MESSAGE IS FORBIDDEN. ONLY  
 SUCH EXTRACTS AS ARE ABSOLUTELY NECESSARY WILL BE MADE AND PROPERLY  
 CLASSIFIED.

0618

HEADQUARTERS  
EASTERN COMMAND  
USSTAF  
OUTGOING MESSAGES

|                |                        |                                    |
|----------------|------------------------|------------------------------------|
| PRECEDENCE     | URGENT                 | DEPUTY COMDR FOR OPS<br>ORIGINATOR |
| CLASSIFICATION | <del>SECRET</del>      | APPROVED, ASSISTANT.               |
| DATE           | 5 August 1944          |                                    |
| SRL NR         | TO: JBPD JBAF (BOUNCE) |                                    |

LOCAL TIME OF ARRIVAL OF PRANTIC FIVE ESTIMATED TO BE TWO ZERO  
ZERO ZERO HOURS AUGUST SIX PD SPATZ FOR DOOLITTLE FROM WALSH  
TOPSEC PART Five ZCYO PD THIS IS TOO LATE FOR DISPERAL  
TO OTHER FIELDS PD RECOMMEND ARRIVAL TIME BE SET AHEAD AT LEAST THREE  
HOURS



THE MAKING OF AN EXACT COPY OF THIS MESSAGE IS FORBIDDEN. ONLY  
SUCH EXTRACTS AS ARE ABSOLUTELY NECESSARY WILL BE MADE AND PROPERLY  
CLASSIFIED.

0619

HEADQUARTERS  
EASTERN COMMAND  
USSTAF  
OUTGOING MESSAGES

|                |                             |                      |
|----------------|-----------------------------|----------------------|
| PRECEDENCE     | URGENT                      | DEPUTY COMDR FOR OPS |
| CLASSIFICATION | <del>SECRET</del>           | ORIGINATOR           |
| DATE           |                             | APPROVED, ASSISTANT. |
| SRL NR         | TO: JJUL JJCQ (BOUNCE) JBPD |                      |
| 7-47           |                             |                      |

RETURNING FIFTEENTH AIR FORCE FIGHTERS OF FRANTIC FOUR INTEND TO  
SWEEP AREA NORTH OF BUCHAREST PD ACKNOWLEDGE PD TO BAKER FOR  
TWINING INFORMATION STATE FROM WALSH TOPSEC TARE FOR SEVEN PD  
TAKE OFF SIX AUGUST ZERO SIX ONE FIVE ZEBRA OMA ESTIMATE TARGET  
AREA ZERO NINE ZERO ZERO ZEBRA THENCE TO ITALIAN BASES

ACKNOWLEDGED BY 2153 (W591E)



THE MAKING OF AN EXACT COPY OF THIS MESSAGE IS FORBIDDEN. ONLY  
SUCH EXTRACTS AS ARE ABSOLUTELY NECESSARY WILL BE MADE AND PROPERLY  
CLASSIFIED.

0 6 2 0

HEADQUARTERS  
EASTERN COMMAND  
USSTAF  
OUTGOING MESSAGES

|                |                        |                     |
|----------------|------------------------|---------------------|
| PRECEDENCE     | URGENT                 | DEPUTY CMDR FOR OPS |
| CLASSIFICATION | SECRET                 | ORIGINATOR          |
| DATE           | 5 AUG 44               | APPROVED, ADJUTANT. |
| SRL NR         | TO: JBPD JBAF (BOUNCE) |                     |
| T 44           |                        |                     |

PLANSABLE BAKER AND CHARLIE FOR FRANTIC FIVE GIVE SOVIET CROSSING  
TIME AS EARLIER REPEAT EARLIER THAN TARGET TIME (PD SPAATZ FOR  
DOOLITTLE FROM WALSH TOPSEC TARE FOUR FOUR PD) RECHECK YOUR RW THREE  
FIVE JD AND ADVISE IMMEDIATELY PD SOVIET INSIST ON EARLY FLIGHT PLAN PD  
NO ARRIVAL TIME SHOWN



THE MAKING OF AN EXACT COPY OF THIS MESSAGE IS FORBIDDEN. ONLY  
SUCH EXTRACTS AS ARE ABSOLUTELY NECESSARY WILL BE MADE AND PROPERLY  
CLASSIFIED.

0 6 2 1

HEADQUARTERS  
EASTERN COMMAND  
USSTAF  
OUTGOING MESSAGES

|                |          |                     |
|----------------|----------|---------------------|
| PRECEDENCE     | PRIORITY | DEPUTY CMDR FOR OPS |
| CLASSIFICATION | SECRET   | ORIGINATOR          |
| DATE           | 4 AUG 44 | APPROVED, ADJUTANT. |
| SRL NR         | TO: JBPD |                     |

FOLLOWING EIGHTH AIR FORCE PERSONNEL MISSING SINCE JUNE TWO ONE  
ARRIVED POLONA THIS AFTERNOON PD SPAATZ FROM CULLEN SIGNED WALSH  
TOPSEC TARE \_\_\_\_\_ SEE YOUR UNCLE SIX FIVE SEVEN EIGHT  
TWO PD SECOND LIEUTS LOUIS ROGER HERNANDEZ OBOE SEVEN FIVE FIVE THREE  
FOUR THREE PILOT CMA ALFRED ROGER LEA OBOE SEVEN ZERO EIGHT THREE  
SIX NINE NAVIGATOR CMA TECH SGT ANTHONY ROGER HUTCHINSON THREE FOUR  
SIX EIGHT FOUR FOUR SIX TWO ENGINEER CMA STAFF SGT ROBERT LOVE SILBERT  
ONE SIX ZERO FOUR FIVE EIGHT EIGHT THREE MUSTANG MECHANIC CMA STAFF  
SGT HERSCHEL LOVE WISE THREE NINE EIGHT FIVE FIVE EIGHT SEVEN SIX  
GUNNER ARE DEPARTING AUGUST <sup>five</sup> SIX VIA TEHRAN FOR ENGLAND PD SECOND  
LIEUT THOMAS JIG MADDEN OBOE EIGHT ONE EIGHT ONE EIGHT TWO COPILOT  
AND SECOND LIEUT JOSEPH CHARLIE BAKER OBOE SEVEN ZERO SIX SIX SIX  
SEVEN BOMBARDIER ARE LEAVING SEVEN AUGUST FOR MOSCOW WITH WALSH PD  
THIS CREW HAS BEEN GIVEN SECURITY INSTRUCTIONS



THE MAKING OF AN EXACT COPY OF THIS MESSAGE IS FORBIDDEN. ONLY  
SUCH EXTRACTS AS ARE ABSOLUTELY NECESSARY WILL BE MADE AND PROPERLY  
CLASSIFIED.

0 6 2 2

Paraphrase of message dated 4 August 1944

Routine

Secret

To: Deane

For: McHenry

Sgd: Walsh

REURAD M20429, WE ANSWERED CITED MESSAGES BY JK 1615

~~SECRET~~

In reply to M20429  
JK 1668 Aed No. 2108

REURAD  
M20429  
BY 1668 JK 30

0623



HEADQUARTERS  
EASTERN COMMAND  
USSTAF  
OUTGOING MESSAGES

|                |                          |                     |
|----------------|--------------------------|---------------------|
| PRECEDENCE     | URGENT                   | DEPUTY CMDR FOR OPS |
| CLASSIFICATION | SECRET                   | ORIGINATOR          |
| DATE           | 4 AUG 44                 | APPROVED, ADJUTANT. |
| SRL NR         | TO: JJHL JJQ(BOUNCE) JBD |                     |

ADDITIONAL AIRCRAFT FROM PRANTIC FOUR HAVE LANDED AT EASTERN  
COMMAND PD THREE ONE LIGHTNINGS AND TEN MUSTANGS AT LOCAL BASES PD  
TWELVE MUSTANGS AND SIX LIGHTNINGS ARE SAFELY DOWN ~~XXX~~ ELSEWHERE  
IN RUSSIA PD LIEUTENANT RICHARD EASY WILLISIE CRASH LANDED IN ROUMANIA  
WITH BOTH ENGINES SHOT OUT CMA FLIGHT OFFICER RICHARD TARE ANDREWS  
LANDED ALONGSIDE AND BY DISCARDING PARACHUTES BOTH PILOTS FLEW TO  
PALTAVA IN ANDREWS AIRPLANE PD BAKER FOR TWINING INFO SPAATE FROM  
CULLER SIGNED WALSH KOSSEC TARE \_\_\_\_\_ PD ANTICIPATE  
ADDITIONAL INFORMATION RE PRANTIC FOUR AIRCRAFT FROM THE SOVIETS  
THIS EVENING



THE MAKING OF AN EXACT COPY OF THIS MESSAGE IS FORBIDDEN. ONLY  
SUCH EXTRACTS AS ARE ABSOLUTELY NECESSARY WILL BE MADE AND PROPERLY  
CLASSIFIED.

0624

HEADQUARTERS  
EASTERN COMMAND  
USSTAF  
OUTGOING MESSAGE

|                |                       |                     |
|----------------|-----------------------|---------------------|
| PRECEDENCE     |                       |                     |
| CLASSIFICATION | URGENT                | DEPUTY CMDR FOR OPS |
|                | SECRET                | APPROVED, ADJUTANT. |
| DATE           | 4 AUGUST 44           |                     |
| SRL NR         | TO: JJHL JJCR( ) JRPD |                     |

HEAVY RAINSTORMS IN RUSSIA HAVE SCATTERED FRANTIC FOUR PD AS OF  
ONE FOUR ZERO ZERO ZEBRA THREE ONE LIGHTNINGS HAVE LANDED AT  
EASTERN COMMAND NO REPEAT NO MUSTANGS PD BAKER FOR TWINING INFO SPREZ  
FROM WALSH TOPSEC TARE \_\_\_\_\_ PD HEAVY BATTLE  
DAMAGE TO LIGHTNINGS AND UNINTENDED DISPERSION MAKE IT IMPRACTICABLE  
TO COMPLY WITH YOUR IE ONE FOUR FIVE ONE NT FOR MISSION ON FIVE  
AUGUST PD ACKNOWLEDGE

ANSWER TO T-37

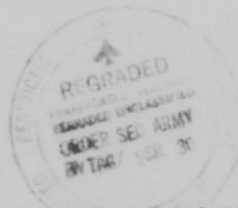

THE MAKING OF AN EXACT COPY OF THIS MESSAGE IS FORBIDDEN. ONLY  
SUCH EXTRACTS AS ARE ABSOLUTELY NECESSARY WILL BE MADE AND PROPERLY  
CLASSIFIED.

0625

HEADQUARTERS  
EASTERN COMMAND  
USSTAF  
OUTGOING MESSAGES

|                |               |                        |
|----------------|---------------|------------------------|
| PRECEDENCE     | URGENT        | P.T. CULLEN, COL, A.C. |
| CLASSIFICATION | SECRET        | ORIGINATOR             |
| DATE           | 3 AUGUST 1944 | APPROVED, ADJUTANT.    |

SRL NR  
T-28 TO: JMR

FRANTIC FOUR IS LAID ON PRN TO DEANE FROM WALSH TOP SECRET TARE  
PRN FOCSANI FOUR AUGUST HOPEFULLY

RE-2070

S

T 28



THE MAKING OF AN EXACT COPY OF THIS MESSAGE IS FORBIDDEN. ONLY SUCH EXTRACTS AS ARE ABSOLUTELY NECESSARY WILL BE MADE AND PROPERLY CLASSIFIED.

0626

HEADQUARTERS  
EASTERN COMMAND  
USSTAF  
OUTGOING MESSAGES

|                |             |                        |
|----------------|-------------|------------------------|
| PRECEDENCE     | URGENT      | P.T. CULLEN, COL, A.C. |
| CLASSIFICATION | SECRET      | ORIGINATOR             |
| DATE           | AUGUST 1944 | APPROVED, ADJUTANT.    |
| SRL NR         | TO: JBPD    |                        |

PLANS ABL CMA BAKER AND CHARLIE FOR FRANTIC FIVE HAVE BEEN SUBMITTED TO SOVIETS WITH SPECIFIC REQUEST FOR DETAILED INFORMATION REGARDING SUITABLE AIRFIELDS FOR STRAFING ATTACK PD [PRN] SPAATZ FROM WALSH TOP SECRET TARE [PRN] OUR REQUEST FOR PHOTO RECONNAISSANCE FLIGHTS TO THE NORTHWEST HAVE BEEN REFUSED EACH DAY FOR THE PAST WEEK PD RECOMMEND PHOTO SHUTTLE FROM ENGLAND TO PICK UP AIRFRAME COVERAGE NORTH WEST OF WARSAW



THE MAKING OF AN EXACT COPY OF THIS MESSAGE IS FORBIDDEN. ONLY SUCH EXTRACTS AS ARE ABSOLUTELY NECESSARY WILL BE MADE AND PROPERLY CLASSIFIED.

0627

HEADQUARTERS  
EASTERN COMMAND  
USSTAF  
OUTGOING MESSAGES

PRECEDENCE URGENT  
CLASSIFICATION ~~SECRET~~ SECRET

F.T. CULLEN, COL, A.C.

DATE 3 AUGUST 1944

ORIGINATOR

APPROVED, ADJUTANT.

SRL NR TO: JJHL, JJCQ (BOUNCE)

SOVIETS NOTIFIED OF FLIGHT PLAN FOR FOUR AUGUST DD TO EAKER AND  
TWINING TOP SECRET FROM WALSH TARE \_\_\_\_\_ PRI WHERE WILL THE  
TWELVE ADDITIONAL LIGHTNINGS LAND QUERY



THE MAKING OF AN EXACT COPY OF THIS MESSAGE IS FORBIDDEN. ONLY  
SUCH EXTRACTS AS ARE ABSOLUTELY NECESSARY WILL BE MADE AND PROPERLY  
CLASSIFIED.

0628

HEADQUARTERS  
EASTERN COMMAND  
USSTAF  
OUTGOING MESSAGES

PRECEDENCE URGENT  
CLASSIFICATION SECRET

F. T. GILLEN,  
COLONEL, AIR CORPS,  
DEPUTY COMMANDER FOR OPS.,  
ORIGINATOR

DATE 3 AUGUST 1944

APPROVED, ADJUTANT.

SRL NR T-23 TO: JJHL

PLEASE FORWARD IMMEDIATELY BULK TARGET MATERIAL AS LISTED PD PAGEN TO BAKER FOR  
TWINING FROM WALSH TOP SEC TAKE TWO THREE PAGEN QUANTITY NEEDED SIX TWO TARGETS CHARTS  
EIGHT BRIEFING CHARTS PD MAAP TARGET NUMBERS ONE SIX DASH SIX DASH NA CIA ONE SIX  
DASH FOUR DASH NA PD IF TARGET CHARTS ARE AVAILABLE FOR BOHEMIA CIA NOR SLANT OSTRAVA  
CIA OPEIN CIA MYJAVA CIA KRAKOW CIA GLEWITZ CIA HINDENBURG CIA HEUTHER CIA  
KATOWICE CIA SHIP LIKE QUANTITIES PD SUGGEST THAT THIS MATERIAL BE  
SHIPPED PIECEMEAL IN SHUTTLE PHOTO RECONN



THE MAKING OF AN EXACT COPY OF THIS MESSAGE IS FORBIDDEN. ONLY  
SUCH EXTRACTS AS ARE ABSOLUTELY NECESSARY WILL BE MADE AND PROPERLY  
CLASSIFIED.

0 6 2 9

HEADQUARTERS  
EASTERN COMMAND  
USSTAF  
OUTGOING MESSAGES

|                |                   |
|----------------|-------------------|
| PRECEDENCE     | URGENT            |
| CLASSIFICATION | <del>SECRET</del> |

P. T. GULLEN,  
COLONEL, AIR CORPS,  
DEPUTY COMMANDER FOR OPS.

DATE 3 AUGUST 1944

APPROVED, ADJUTANT.

SRL NR  
T-21

TO: JHPD, JBAF AND JHHL

NO SPECIFIC INFORMATION HERE ON UPPER SILESIA, OR KRAKOW AREA WHICH IS NOT AVAILABLE  
TO YOU <sup>PAKEN</sup> TO SPAATZ FOR DO LITTLE AND BAKER TOP SEC TAKE TWO ONE <sup>SIGNED WALSH</sup> PAKEN POOR  
WEATHER HAS LIMITED COVERAGE THESE AREAS SINCE JUNE EARLY PD SOVIETS HAVE  
BEEN REQUESTED TO FURNISH TARGET INFORMATION PD SOVIETS ASSERT THAT  
KRAKOW IS AN OIL CENTER PD REURAD UNCLE XRAY SIX FIVE EIGHT THREE  
BELIEVE ENOUGH MUSTANG PARTS FOR FRANTIC FIVE ON HAND



THE MAKING OF AN EXACT COPY OF THIS MESSAGE IS FORBIDDEN. ONLY  
SUCH EXTRACTS AS ARE ABSOLUTELY NECESSARY WILL BE MADE AND PROPERLY  
CLASSIFIED.

0 6 3 0



HEADQUARTERS  
EASTERN COMMAND  
USSTAF  
OUTGOING MESSAGES

PRECEDENCE  
CLASSIFICATION ~~SECRET~~ ~~SECRET~~

P. T. DILLON  
COLONEL, AIR CORPS,  
DEPUTY COMMANDER FOR OF  
ORIGINATOR

DATE 3 AUGUST 1944

APPROVED, ADJUTANT.

SRL NR

7-20

TO: JJHL JJCL (BOUNCE) MAPN (BOUNCE) JEPD

FLIGHT PLANS ON FRANTIC FOUR CMA ON TWO FORTRESSES AND FOR TWO  
FOX FIVES FOR AUGUST FOUR, PD PAREN TAKER FOR THIRING AND POLIFKA  
INFO SPAATZ FROM KESSLER SIGNED WALSH TARE TWO ZERO

PAREN UNLESS NOTIFIED OTHERWISE LET THEM COME



7-20

THE MAKING OF AN EXACT COPY OF THIS MESSAGE IS FORBIDDEN. ONLY  
SUCH EXTRACTS AS ARE ABSOLUTELY NECESSARY WILL BE MADE AND PROPERLY  
CLASSIFIED.

0631

**SECRET**HEADQUARTERS  
EASTERN COMMAND  
USSTAF

## OUTGOING MESSAGES

PRECEDENCE  
CLASSIFICATION

ORIGINATOR

DATE 5 AUGUST 1966

APPROVED, ASSJAIT.

SRL NR  
7-13

TO: 3020 0401

CONFERENCE WITH MEMBERS WAS HELD TODAY AT WHICH THE SOVIETS  
 IS REPORTED THAT THE OPERATIONS UNIT ATTACK 2 OF THE FOLLOWING ARE  
 ONLY NEW RESEARCH UNIT UNIT IN THE LINE DATA APPROXIMATELY 20  
 MINUTE AND DURING THIS PERIOD THERE WAS NO THREAT TO  
 VICTORY AS REPORTED IN THE LATEST DATA QUARTERS WITH THE  
 UNIT AND THAT NEW RESEARCH UNIT IS BEING FORMED WITH THE  
 THIRD IN COMMAND OF THE UNIT BEING REPORTED AS HAVING IN THE  
 LINEUP IN THIS REGARD TO THE USE OF AIRCRAFT OPERATIONS WHICH WOULD  
 BE IN THE LINE OF DATA AS THIS IS THE NEXT STAGE IN THE  
 DEVELOPMENT OF THE OPERATIONS UNIT WHICH IS BEING FORMED  
 IN ORDER TO BE ABLE TO OPERATE IN THE LINE OF DATA AS  
 THE USE OF THIS RESEARCH UNIT WILL BE ABLE TO BE USED  
 IN ORDER TO BE ABLE TO OPERATE IN THE LINE OF DATA AS  
 IN ORDER TO BE ABLE TO OPERATE IN THE LINE OF DATA AS  
 IN ORDER TO BE ABLE TO OPERATE IN THE LINE OF DATA AS  
 IN ORDER TO BE ABLE TO OPERATE IN THE LINE OF DATA AS



THE MAKING OF AN EXACT COPY OF THIS MESSAGE IS FORBIDDEN. ONLY  
 SUCH EXTRACTS AS ARE ABSOLUTELY NECESSARY WILL BE MADE AND PROPERLY  
 CLASSIFIED.

COPY

0 6 3 2  
1 6 4 7

HEADQUARTERS  
EASTERN COMMAND  
USSTAF  
OUTGOING MESSAGES

P.T. CULLEN, COL, A.C.  
DEPUTY CO-OPNS

|                |                         |                     |
|----------------|-------------------------|---------------------|
| PRECEDENCE     | OPS PRIORITY            | ORIGINATOR          |
| CLASSIFICATION | <del>SECRET</del>       | APPROVED, ASJUTANT. |
| DATE           | 2 AUGUST 1944           |                     |
| SRL NR         | TO: JJHL, (BOUNCE) JJCG |                     |

CLEARANCE REQUESTED BY YOUR WILLIAM FOUR SIX NAB TARE. SUBMITTED  
TO RUSSIANS PD TO EAKER AND TRAINING FROM WALSH TOP SECRET TARE  
ONE TWO PRN TIME GIVEN OVER CITED CHECKPOINT IS ZERO FIVE  
TWO ONE ZEDRA RPT ZEDRA **ALRIGHT**

TOP SECRET

RE: W 46 1E

T-12

THE MAKING OF AN EXACT COPY OF THIS MESSAGE IS FORBIDDEN. ONLY  
SUCH EXTRACTS AS ARE ABSOLUTELY NECESSARY WILL BE MADE AND PROPERLY  
CLASSIFIED.

0633

HEADQUARTERS  
EASTERN COMMAND  
USSTAF

OUTGOING MESSAGES

P.T. CULLEN, COL AC  
DEPUTY CHIEF FOR OPS

PRECEDENCE PRIORITY

CLASSIFICATION SECRET

DATE 2 AUGUST 1944

ORIGINATOR \_\_\_\_\_

APPROVED, AUTHORITY \_\_\_\_\_

SRL NR T-11 TO: JSPD

PLANNING PURPOSES REQUIRE INFORMATION REGARDING TYPE OF  
FIGHTER MENTIONED IN YOUR UNCLE XRAY SIX FIVE SEVEN NINE  
FOUR PD SPAATZ FROM KESSLER SIGNED WALSH TOPSEC TARE ONE  
ONE PD WILL RETURN THREE ZERO SIX WING LIGHTNING  
MECHANICS BY ATC AFTER FRANTIC FOUR IMMEDIATELY

ANSWERED BY 2115 (U65922)

RE: UY 65794

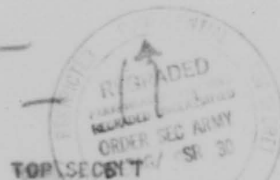

THE MAKING OF AN EXACT COPY OF THIS MESSAGE IS FORBIDDEN. ONLY  
SUCH EXTRACTS AS ARE ABSOLUTELY NECESSARY WILL BE MADE AND PROPERLY  
CLASSIFIED.

0634

HEADQUARTERS  
EASTERN COMMAND  
USSTAF  
OUTGOING MESSAGES

|                     |                   |                       |
|---------------------|-------------------|-----------------------|
| PRECEDENCE          | PRIORITY          | By: <del>SECRET</del> |
| CLASSIFICATION      | <del>SECRET</del> | ORIGINATOR            |
| DATE: 2 AUGUST 1944 |                   | APPROVED, ASSYDATT.   |
| SRL NR<br>JK-1619   | TO:               | MESSAGE CENTER        |

RELAY MESSAGE NUMBER U-65785 to MOSCOW

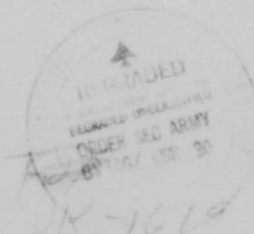

THE MAKING OF AN EXACT COPY OF THIS MESSAGE IS FORBIDDEN. ONLY SUCH EXTRACTS AS ARE ABSOLUTELY NECESSARY WILL BE MADE AND PROPERLY CLASSIFIED.

0 6 3 5

HEADQUARTERS  
EASTERN COMMAND  
USCJAF

OUTGOING MESSAGES

P.T. CULLEN, COL AC

DEPUTY CMDR FOR OPS

|                |         |
|----------------|---------|
| PRECEDENCE     | ROUTINE |
| CLASSIFICATION | SECRET  |

ORIGINATOR

DATE 2 AUG 1954

APPROVED, ASSISTANT

SRL NR

TO: JBPD JJHL

CONDITIONS REPORTED IN UNCLE SIX FIVE SEVEN ONE TWO HAVE BEEN THE SUBJECT OF STRINGENT MEDICAL INVESTIGATION AND ACTION PD ADEQUATE MESS PERSONNEL WERE NEVER PROVIDED THIS COMMAND PD ONE MESS SGT AND TWO COOKS WERE BORROWED FROM PGC TO GIVE A TOTAL OF FIVE MESS SGTs AND ELEVEN COOKS TO FEED TWO THOUSAND MEN IN SEVEN SEPARATE MESSes INCLUDING HOSPITALS PD CONDITIONS REPORTED BROKE OUT IN THREE DIFFERENT LOCATIONS SIMULTANEOUSLY THE FIRST INSTANCES IN THE HISTORY OF THIS COMMAND PD INDICATIONS ARE THAT THE MAJOR SOURCES OF INFECTION WERE DISPERSAL AIRDROMES CMA POOR WATER DISCIPLINE AND FRESH LOCAL FRUIT PD IF DISPERSAL FIELDS ARE USED THEN RUSSIAN ACCOMMODATIONS ARE ALL THAT ARE AVAILABLE CMA REPEATED UNSUCCESSFUL EFFORTS HAVE BEEN MADE TO HAVE MOSCOW DESIGNATE DEFINITE DISPERSAL AIRDROMES FOR THIS COMMAND PD DISPERSAL AIRDROMES WERE DESIGNATED JUST PRIOR TO THE MISSION AND VARY FOR EACH MISSION PD ADEQUATE PRELIMINARY ARRANGEMENTS CANNOT BE MADE UNDER THESE CIRCUMSTANCES PD YOU ARE FAMILIAR WITH THE DIPLOMATIC DIFFICULTIES BEING ENCOUNTERED REGARDING A FOURTH BASE PD FURTHER NEITHER AMERICAN PERSONNEL NOR EQUIPMENT ARE AVAILABLE TO AMERICANIZE DISPERSAL FIELDS WHEN IT IS REALIZED THAT IN Bases ARE FORCED TO RELY UPON SOVIET ASSISTANCE FOR ALL PERSONNEL EXCEPT A MINIMUM OF SUPERVISORY PD SUFFICIENT SOVIET PERSONNEL APPARENTLY CANNOT BE MADE AVAILABLE LOCALLY PD FURTHERMORE VISAS ARE NOT REPEAT NOT PRESENTLY

THE MAKING OF AN EXACT COPY OF THIS MESSAGE IS FORBIDDEN. ONLY SUCH EXTRACTS AS ARE ABSOLUTELY NECESSARY WILL BE MADE AND PROPERLY CLASSIFIED.

- OVER -

0636

~~SECRET~~ SECRET

P.T. CULLEN, COL, A.C.  
DEPUTY CO FOR OPS

OPS PRIORITY

~~SECRET~~ SECRET

2 AUGUST 1944

JJHL Bouice JJCQ

DISTRIBUTE AIRCRAFT FOR FRANTIC FOUR AS FOLLOWS COLON THREE SIX  
MUSTANGS AT PIRYATIN CMA TWO FOUR LIGHTNINGS AT MIRGOROD CMA  
TWO FOUR LIGHTNINGS AT POLTAVA PD PRN TOP SECRET TO EAKER FOR  
TWINING FROM WALSH TARE \_\_\_\_\_ PRN RUSSIANS HAVE BEEN  
NOTIFIED PD REQUEST WE BE NOTIFIED PROMPTLY OF UNITS CMA DISTRIBUTIO  
AND CALL SIGNS PD NO REPEAT NO INFORMATION RECEIVED HERE  
REGARDING SHIPMENT OF TWENTY MILLIMETER OR ARMOR PIERCING  
INCENDIARY AMMUNITION.



0637



SECRET  
HEADQUARTERS  
EASTERN COMMAND  
USSTAF

OUTGOING MESSAGES

PRECEDENCE URGENT  
CLASSIFICATION TOP SECRET  
DATE 2 AUGUST 1944

P. T. CULLEN, COL, A.C.  
DEPUTY CO FOR OPS

ORIGINATOR

APPROVED, ADJUTANT.

SRL NR

TO: JMRR

ANTICIPATE FRANTIC FOUR ON OR AFTER AUGUST THREE PD PRN TOP SECRET  
DEANE FOR WALSH FROM CULLEN SIGNED WALSH TARE \_\_\_\_\_ PRN  
CHARLIE FOUR SEVEN COMING YOUR WAY ON ~~SCHEDULE~~ SCHEDULE.



*Answered by [signature]*  
*local copies + etc [unclear] [unclear] [unclear]*  
*to see [unclear] [unclear] for [unclear]*  
*7-1*

THE MAKING OF AN EXACT COPY OF THIS MESSAGE IS FORBIDDEN. ONLY SUCH EXTRACTS AS ARE ABSOLUTELY NECESSARY WILL BE MADE AND PROPERLY CLASSIFIED.

0638

HEADQUARTERS  
EASTERN COMMAND  
USSTAF  
OUTGOING MESSAGES

|                   |                   |  |                      |
|-------------------|-------------------|--|----------------------|
| PRECEDENCE        | PRIORITY          |  | COLONEL L. B. NICKAM |
| CLASSIFICATION    | <del>SECRET</del> |  | ORIGINATOR           |
| DATE 31 JULY 1944 |                   |  | APPROVED, ADJUTANT.  |
| SRL NR<br>JK 1594 | TO: SPAATZ        |  |                      |

VISA SITUATION IS CRITICAL AND SHOWS NO SIGN OF IMPROVEMENT PD SPAATZ IS  
INFO CONNOLLY ~~WALSH~~ SIGNED WALSH *JK KWC ONE FIVE NINE FOUR*  
TO ALLEVIATE THIS CONDITION ~~WALSH~~ <sup>HAVE</sup> <sup>OUT</sup> DECIDED TO SEND FIFTY BODIES PD  
IT IS PROPOSED THESE BE SENT TO TIRHAN AND HELD THERE PD TO ACCOMPLISH  
THIS WE PROPOSE TO SEND SELECTED LEAST NEEDED BAKER SEVENTEENS MECHANICS  
PD THIS DECISION BASED ON THE FACT THAT WE ARE SET UP TO RECEIVE MISSIONS  
OF ONE FOUR ZERO BAKER SEVENTEENS WHEREAS IT HAS BEEN RECOMMENDED THAT  
FUTURE MISSIONS BE ON BASIS OF SIXTY TO SEVENTY OF THIS TYPE AIRCRAFT PD  
REQUEST YOUR CONCURRENCE THIS REDUCTION NUMBERS OF BAKER SEVENTEENS SO  
THAT PLAN CAN BE CARRIED OUT WITHOUT JEOPARDIZING PROJECT

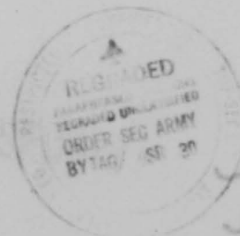

THE MAKING OF AN EXACT COPY OF THIS MESSAGE IS FORBIDDEN. ONLY  
SUCH EXTRACTS AS ARE ABSOLUTELY NECESSARY WILL BE MADE AND PROPERLY  
CLASSIFIED.

0639

HEADQUARTERS  
EASTERN COMMAND  
USSTAF

OUTGOING MESSAGES

P.T. CULLEN, COL AG  
DEPUTY CO FOR OPS

|                |                          |
|----------------|--------------------------|
| PRECEDENCE     | ROUTINE                  |
| CLASSIFICATION | <del>SECRET</del> SECRET |

DATE 31 JULY 1944

ORIGINATOR \_\_\_\_\_  
APPROVED, ADJUTANT. \_\_\_\_\_

SRL NR T 664 TO: JBDP

UP GRADING OF TARE SIX FOUR NINE JULY THREE ZERO NOT NECESSARY HERE  
BECAUSE MESSAGE WAS PREPARED AND HANDLED AS TOP SECRET IN THIS  
TOPSEC  
HEADQUARTERS PD/SPAATZ FROM WALSH TARE SIX SIX FOUR PD  
REFERENCE YOUR UNCLE SIX FIVE SEVEN ZERO FIVE CMA ALL MATERIAL PERTAINING  
TO THIS PROJECT HAS BEEN CLASSIFIED TOPSEC AND HANDLED ACCORDINGLY PD  
ERROR IN THIS CASE WAS IN TRANSMISSION OF MESSAGE IN QUESTION

ANSWER TO  
U 65705- (1968)

Re "Dalle" project



664

THE MAKING OF AN EXACT COPY OF THIS MESSAGE IS FORBIDDEN. ONLY  
SUCH EXTRACTS AS ARE ABSOLUTELY NECESSARY WILL BE MADE AND PROPERLY  
CLASSIFIED.

0640

HEADQUARTERS  
EASTERN COMMAND  
USSTAF  
OUTGOING MESSAGES

|                |                         |                             |
|----------------|-------------------------|-----------------------------|
| PRECEDENCE     | OPS PRIORITY <i>777</i> | P.T. CULLEN                 |
| CLASSIFICATION | <del>TOP SECRET</del>   | COL AC<br>DEPUTY CO FOR OPS |
| DATE           | 31 JULY 1944            | ORIGIATOR                   |
| SRL NR         | TO: JHNL                | APPROVED, ADJUTANT.         |
| <i>T-663</i>   |                         |                             |

CONNECTION WITH FRANTIC FOUR CLN MECHANICS OF GROUND ECHELON THREE  
ZERO SIX WING ARE BEING RETAINED FOR FRANTIC FOUR OPERATION PD EAKER  
FROM CULLEN SIGNED WALSH TARE SIX SIX THREE TOP SEC PD  
NO RPT NO VISAS ARE AVAILABLE FOR INCOMING PERSONNEL AT TEHRAN PD  
ANY ADDITIONAL PERSONNEL REQUIRED AT ESCOM BY THE FIFTEENTH AIR  
FORCE FOR FRANTIC FOUR SHOULD BE BROUGHT IN COMBAT AIRCRAFT WITH  
THE MISSION



THE MAKING OF AN EXACT COPY OF THIS MESSAGE IS FORBIDDEN. ONLY  
SUCH EXTRACTS AS ARE ABSOLUTELY NECESSARY WILL BE MADE AND PROPERLY  
CLASSIFIED.

0641

HEADQUARTERS  
EASTERN COMMAND  
USSTAF  
OUTGOING MESSAGES

F. T. CHILLEN, COL., A.D.

|                |          |
|----------------|----------|
| PRECEDENCE     | PRIORITY |
| CLASSIFICATION | SECRET   |

DEPUTY CO FOR OPS  
ORIGINATOR

APPROVED, ASSJUTANT.

DATE JULY 30

SRL NR

TO:

T-651

TO : DEANE  
FOR : WALSH  
FROM : REISLER

JEDLICEZ, JASLO AND GILRICK, SINCE RED ASY IS DEAR, ARE NOT TARGETS ADD REISS  
TO SCOPLET INFO.  
THIS WAS RE A RELATED TO EARL

Re 1931

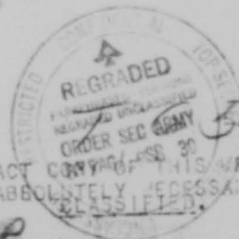

THE MAKING OF AN EXACT COPY OF THIS MESSAGE IS FORBIDDEN. ONLY  
SUCH EXTRACTS AS ARE ABSOLUTELY NECESSARY WILL BE MADE AND PROPERLY  
CLASSIFIED.

TOP

0642

HEADQUARTERS  
EASTERN COMMAND  
USSTAF  
OUTGOING MESSAGE

PRECEDENCE  
CLASSIFICATION URGENT  
SECRET  
DATE 30 JULY 1944

F. T. CULLEN,  
COLONEL, AIR CORPS,  
DEPUTY COMMANDER FOR OPS.  
ORIGINATOR

APPROVED, ADJUTANT.

SRL NR  
T-650 TO: JJHL

SOVIETS HAVE JUST STATED THAT THE OIL REFINERIES AT JASLO OMA JEDLIZE  
AND GLINIK ARE NO REPEAT NO LONGER TARGETS PAREN EASER FROM CULLEN SIGNED  
WALSH TARE SIX FIVE ZERO FOR SEC PAREN F R USSTAF BECAUSE OF THE  
APPROACH OF THE ADVANCE ELEMENTS OF THE RED ARMY

Approved 1981  
T 650

R. [unclear]  
ORDER SEC ARMY  
BY [unclear] [unclear]

THE MAKING OF AN EXACT COPY OF THIS MESSAGE IS FORBIDDEN. ONLY  
SUCH EXTRACTS AS ARE ABSOLUTELY NECESSARY WILL BE MADE AND PROPERLY  
CLASSIFIED.

0643



HEADQUARTERS  
EASTERN COMMAND  
USSTAF  
OUTGOING MESSAGES

|                |                   |                     |
|----------------|-------------------|---------------------|
| PRECEDENCE     | ROUTINE           | COL P. T. GILLEN    |
| CLASSIFICATION | <del>SECRET</del> | DEF ORDER FOR OPS   |
| DATE           |                   | ORIGINATOR          |
| SERIAL NR      | TO: JPB           | APPROVED, ASJUTANT. |
| 7-619          |                   |                     |

ROUND UP OF DULLY RPT DULLY PROJECT PD AMBASSADOR HAS CONTACTED FOREIGN OFFICE  
STATING CONDITIONS AND WILLINGNESS TO TRANSPORT PD NO ACTION FROM SOVIETS TO  
DATE PD POLTAVA INFORMED OF REQUIREMENTS PD/SPAATZ FROM OUL IN SIGNATURE ~~WALLEN~~  
CITE TAKE SIX FOUR NINE PAREN ARRANGEMENTS WITH R.D AIR FORCE WILL BE MADE  
IMMEDIATELY ON APPROVAL BY FOREIGN OFFICE PD

RELAY OF MESSAGE FROM MOSCOW VIA TEHRAN TO BUL  
(14)



THE MAKING OF AN EXACT COPY OF THIS MESSAGE IS FORBIDDEN. ONLY  
SUCH EXTRACTS AS ARE ABSOLUTELY NECESSARY WILL BE MADE AND PROPERLY  
CLASSIFIED.



HEADQUARTERS  
EASTERN COMMAND  
USSTAF  
OUTGOING MESSAGES

|                |          |                     |
|----------------|----------|---------------------|
| PRECEDENCE     | PRIORITY | ORIGINATOR          |
| CLASSIFICATION |          | APPROVED, ADJUTANT. |
| DATE           | JULY 30  |                     |
| SRL NR         |          |                     |
| T-646          | TO:      | MESSAGE CENTER      |

RELAY MOSCOW 20931 to Spaatz for McDonald for info.

Red #1915 - CAT A/c test record - Engine Serial numbers



THE MAKING OF AN EXACT COPY OF THIS MESSAGE IS FORBIDDEN. ONLY SUCH EXTRACTS AS ARE ABSOLUTELY NECESSARY WILL BE MADE AND PROPERLY CLASSIFIED.

0645

HEADQUARTERS  
EASTERN COMMAND  
USSTAF  
OUTGOING MESSAGES

|                |               |   |
|----------------|---------------|---|
| PRECEDENCE     | OPS. PRIORITY | J. T. GULISH,   |
| CLASSIFICATION | SEC           | COLONEL, AIR CORPS,<br>DEPUTY CHIEF OF STAFF FOR OPS.<br>ORIGINATOR |
| DATE           | 30 JULY 1944  | APPROVED, ADJUTANT.   |
| SRL NR         | TO:           |   |
| UK-1562        | MESSAGE ENTER |   |

RELAY TOP SIG MESSAGE TO HONCON FOR GENERAL WALSH. MESSAGE NUMBER ~~UK~~ UK-65659.

(1936)

Re Mission Plans (1936)

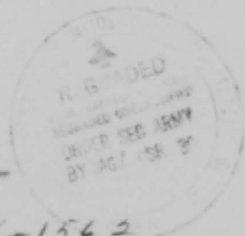

UK-1562

THE MAKING OF AN EXACT COPY OF THIS MESSAGE IS FORBIDDEN. ONLY SUCH EXTRACTS AS ARE ABSOLUTELY NECESSARY WILL BE MADE AND PROPERLY CLASSIFIED.

0646

COL. F. T. CULLEN,  
INTELLIGENCE

ROUTINE  
~~SECRET~~

30 JULY 1944

JJPD JJHL

*PART ONE OF THREE*

~~THREE PARTS~~ PART ONE PD FOLLOWING FIGURES HAVE BEEN SUPPLIED  
 BY RUSSIANS PD PARTS TO SPANZ AND KAZER SIGNED WALSH JIG KING  
ONE FIVE SIX 916 PARTS HEADING FOR ITEM ONE CLN NUMBER OF  
 SORTIES OF THE LUFTWAFFE ON RUSSIAN FRONT FOR MONTH OF JUNE OMA  
 ONE NINE FOUR FOUR PD LIST IN TWO COLUMNS PD COLUMN ONE OMA TYPE  
 OF AIRCRAFT PD COLUMN TWO OMA NUMBER OF SORTIES PD ~~PART TWO PD~~  
 NINE OMA TWO SEVEN EIGHT EIGHT PD FV DASH ONE NINE ZERO OMA FOUR NINE  
 ZERO NINE PD HE DASH ONE ONE ZERO OMA FOUR ZERO EIGHT PD JU DASH  
 EIGHT SEVEN OMA THREE THREE NINE SIX PD JU DASH EIGHT EIGHT OMA FOUR  
 ZERO SEVEN SIX PD HE DASH ONE ONE ONE OMA TWO TWO EIGHT ZERO PD HE  
 DASH ONE SEVEN SEVEN OMA ONE FIVE PD DO DASH TWO ONE FIVE DASH TWO  
 ONE SEVEN OMA ONE FIVE FIVE PD HESCH DASH ONE TWO THREE DASH ONE TWO  
 FIVE OMA SIX EIGHT SIX PD HESCH DASH ONE TWO SIX OMA SIX ZERO TWO  
 PD FV DASH ONE EIGHT NINE OMA ONE FOUR FIVE THREE PD UNIDENTIFIED  
 TYPES OMA SEVEN ONE ZERO PD TOTAL OMA TWO ONE FOUR SEVEN EIGHT PD  
 PART THREE PD HEADING FOR ITEM TWO CLN enemy AIRFORCE LOSSES ON  
 SOVIET FRONT FOR MONTH OF JUNE ONE NINE FOUR FOUR PD LIST IN TWO  
 COLUMNS SAME AS ABOVE PD COLUMN ONE OMA TYPE OF AIRCRAFT PD COLUMN  
 TWO OMA NUMBER OF AIRCRAFT PD JU DASH EIGHT SEVEN ONE ONE ONE SEVEN  
 PD JU DASH EIGHT EIGHT OMA SEVEN FIVE PD HE DASH ONE ONE ONE OMA  
 ONE ONE PD DO DASH TWO ONE FIVE OMA ONE PD HE DASH ONE ONE SEVEN

*L/K 1561*



0647

ROUTINE  
SECRET

30 JULY 1944

PAGE 2

JJPD JJPL

DIA ONE PD TO DASH TWO ONE FIVE DIA ONE PD HE DASH ONE KKK SEVEN  
 SEVEN DIA ONE PD DO DASH TWO ONE SEVEN DIA THREE PD DO DASH TWO  
 FOUR DIA TWO PD ALBERT DIA THREE PD PW DASH ONE EIGHT SEVEN DIA TWO  
 PD HE ONE ONE ZERO PD HE DASH ONE ZERO NINE DIA THREE FIVE THREE PD  
 PW DASH ONE NINE ZERO DIA THREE SIX FOUR PD CURTIS DASH THREE SIX  
 DIA ONE TWO PD MORAN DASH FOUR ZERO SIX DIA ONE PD FLAT DASH FIVE  
 ZERO DIA ONE SEVEN PD SPENCER DIA FOUR SEVEN PD PD DASH TWO ONE DIA  
 ONE PD GLADIATOR DIA TWO PD TEL DASH TWO FOUR DIA ONE PD WEST DASH  
 ONE TWO NINE DIA THREE PD PW DASH ONE EIGHT NINE DIA ONE ONE PD RESCH  
 DASH ONE TWO SIX DIA ONE SIX PD JU DASH FIVE TWO DIA ONE ZERO PD GA  
 DASH ONE THREE EIGHT DIA THREE PD DAS ONE FIVE SIX DIA ONE PD GO DASH  
 EIGHT FIVE DIA THREE PD UNIDENTIFIED YEARS DIA ONE THREE FOUR PD  
 TOTAL DIA ONE TWO THREE FIVE AIRMAIL PD

UK 1561



0648

HEADQUARTERS  
EASTERN COMMAND  
USSTAF  
OUTGOING MESSAGES

PRECEDENCE OPV. PRIORITY

CLASSIFICATION SECRET

DATE 30 JULY 1964

P. T. CULLEN,  
COL INF, AIRCORPS,  
DEPUTY COMMANDER FOR OPS.  
ORIGINATOR

APPROVED, ASSISTANT.

SRL NR

T-637

TO:

JJHL

CONTENTS OF YOUR THREE EIGHT ITEM EASY CHARLIE SUGAR NINE ONE BLANK ITEM EASY NINE TAKE  
FOUR ONE ZERO ITEM EASY TRANSMITTED TO SOVIET WITH FOLLOWING REACTION PAREN WAKER  
FROM CULLEN SIGNED WALSH TAKE SIX THREE SEVEN TOP SEC PAREN ANTICIPATE MAIN DRIVE  
WILL BE WESTWARD BETWEEN WARSAW AND KRAKOW BY PASSING THE HILLY COUNTRY CONTAINING  
THE REFINERIES AND CHEMICALS SILEZIA FROM THE NORTH WEST PD HOWEVER THIS IS  
CORROBORATED AND DISCOM IS BEING QUESTIONED PD IT IS DOUBTFUL IF THE COMMANDER OF THE  
FRONT WILL GIVE HIS INTENTIONS PD AT PRESENT THE FRONT IS SIX ZERO MILES FROM JEDLICE  
AND THE SOVIETS WILL APPRECIATE AIR ATTACK ON SUITABLE TARGETS IN HUNGARY COUNTRY  
BEING SOUTH OF THEIR SPREAD PD VERY DIFFICULT TO GET DEADLINE DATE

T-637

Relayed to Moscow

RECEIVED  
JUL 31 1964  
OFFICE OF THE  
DEPUTY CHIEF OF STAFF  
USSTAF  
T-642

Answers 38 IE  
410 IE

589 IE

THE MAKING OF AN EXACT COPY OF THIS MESSAGE IS FORBIDDEN. ONLY  
SUCH EXTRACTS AS ARE ABSOLUTELY NECESSARY WILL BE MADE AND PROPERLY  
CLASSIFIED.

0649

HEADQUARTERS  
EASTERN COMMAND  
USSTAF  
OUTGOING MESSAGES

|                |          |                                 |
|----------------|----------|---------------------------------|
| PRECEDENCE     | PRIORITY | F. T. GILLEN, COL., A.C.        |
| CLASSIFICATION | CLEAR    | DEPUTY CO FOR QCS<br>ORIGINATOR |
| DATE JULY 29   |          | APPROVED, ASSISTANT.            |
| SRL NR         | TO:      |                                 |
| JK 1545        | JNJK     | message center                  |

RELAY BOARD TEXT OF TORONTO MESSAGE U-65526 FROM JNPK JULY 27 to JNRR.

(1338)

*RAF - [unclear] - [unclear]*



THE MAKING OF AN EXACT COPY OF THIS MESSAGE IS FORBIDDEN. ONLY SUCH EXTRACTS AS ARE ABSOLUTELY NECESSARY WILL BE MADE AND PROPERLY CLASSIFIED.

0 6 5 0

~~SECRET~~  
ROUTINE

COL. P. T. CULLEN,  
INTELLIGENCE.

29 JULY 1944

JBFD JJHL

HEREWITH OUR BEST ESTIMATE OF GEORGE ABLE FOX DISPOSITION BY RUSSIAN  
FRONTS:CLN KARELIAN 95 CMA LENINGRAD 71 CMA THIRD BALTIC 80 CMA SECOND  
BALTIC 139 CMA FIRST BALTIC 273 CMA THIRD WHITE RUSSIAN 308 CMA SECOND  
WHITE RUSSIAN 130 CMA FIRST WHITE RUSSIAN 365 CMA FIRST UKRANIAN 288  
CMA SECOND UKRANIAN 340 CMA THIRD UKRANIAN 546 PD PAREN TO ZAKER -  
SPAATZ - DOOLITTLE FROM WALSH JIG KING \_\_\_\_\_ PAREN  
REPORT INCLUDES ONE TWO SEVEN GERMAN HELD AIRDROMES ON WHICH WE HAVE  
RECEIVED COVERAGE FIGURES DURING JULY PD IN SOME INSTANCES ONLY COVER-  
AGE WAS EARLY IN JULY MAKING RELIABILITY OF COUNT QUESTIONABLE BUT  
MAJORITY OF COVERAGE JULY ONE FIVE AND LATER PD WE NOTE TOTAL EXCEEDS  
USSTAF ESTIMATE PD PARTIAL EXPLANATION IS SOME NON OPERATIONAL AIRCRAFT  
INCLUDED IN THESE FIGURES CMA ALL OF WHICH ARE COMPILED FROM RUSSIAN  
SOURCES OF INFORMATION WHICH FAIL TO DESCRIBE TYPE AIRCRAFT IN MOST  
INSTANCES PD IMPOSSIBLE TO ESTIMATE DUPLICATION OF COUNT CAUSED BY  
MOVEMENT OF GEORGE ABLE FOX AMONG THEIR AIRDROMES PD CONCLUSION CLN  
FIGURES ONLY RELIABLE IN GIVING GENERAL PICTURE OF RELATIVE CONCEN-  
TRATION OF AIRCRAFT BY FRONTS PD WE CAN FORWARD ENTIRE LIST OF AIR-  
DROMES CMA DATE OF LATEST COVERAGE AND AIRCRAFT OBSERVED IF DESIRED PD  
U.S. PHOTO INTERPRETATION REPORTS NOT INCLUDED HEREWITH BUT IS BEING SENT YOU AS  
~~YOUR COMMENTS ON INFORMATION IS REQUESTED FOR OUR GUIDANCE PD~~  
COVERAGE IS OBTAINED BY OUR PRJ

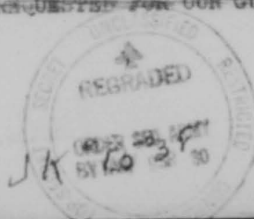

0651



COL. P. T. CULLEN

INTELLIGENCE

ROUTINE  
SECRET

29 JULY 1944

SECRET

JK 1535 JPBD

SOVIET METHOD OF DETERMINING ESTIMATES OF RUSSIAN FRONT  
WASTAGE NOT KNOWN RPT NOT KNOWN BY THIS HEADQUARTERS PD  
WILL ENDEAVOR TO ASCERTAIN PD PAREN TO SPAATZ FROM WALSH  
JIG KING 1535 PAREN UNCLE I-RAY  
SIX FIVE ONE EIGHT SEVEN IS MESSAGE REFERRED TO PD



JK 1535  
Answer to UX 65187  
ref no. 1604

0652

COL. P. T. CULLEN

INTELLIGENCE

ROUTINE  
SECRET

LAB

29 JULY 1944

JBPD

PERTAINING TO YOUR MESSAGE UNCLE X-RAY SIX FIVE FIVE TWO SIX  
HAVE REQUESTED INFORMATION ON PRISONER OF WAR REPORTS AS OUT-  
LINED BY YOU PD PAREN TO SPAATE SIGNED WALSH JIG WING 1536

\_\_\_\_\_ PAREN NEW SUBJECT PD OUR OWN PHOTO RECON  
REPORTS GIVE TYPE AIRCRAFT IN DETAIL PD MAY BE SOME DIFFICULTY  
IN PROCURING SAME INFORMATION ON PHOTO RECON REPORTS FROM  
RUSSIAN SOURCES PD NEW SUBJECT PD WILL BEGIN SPECIAL REPORT ON  
DISPOSITION OF GAF AS SOON AS POSSIBLE BUT OUR MAJOR SOURCE OF  
INFORMATION WILL BE RUSSIAN INFORMATION BULLETIN WHICH IS CUR-  
RENTLY BEING SENT YOU DAILY.

Answers 1536

JK 1536



0653

COL. P. T. CULLEN

INTELLIGENCE

ROUTINE

~~SECRET~~

29 JULY 1944

WE HAVE RECEIVED YOUR LETTER DATED ONE FOUR JULY DISCUSSING  
ESCAPE AND EVASION INFORMATION PD PAREN TO SPAATZ ATTENTION  
WEICKER SIGNED WALSH TOP SECRET JIG KING 15-34  
PAREN USING McDONALD'S LETTER TO WEICKER AS GUIDE WILL AT-  
TEMPT TO PROCURE INFORMATION PD



JK 1534

0654

HEADQUARTERS  
EASTERN COMMAND  
USSTAF  
OUTGOING MESSAGE

|                |                   |
|----------------|-------------------|
| PRECEDENCE     | URGENT            |
| CLASSIFICATION | <del>SECRET</del> |
| DATE           | 29 JULY 1944      |

P. T. GILLEN,  
COLONEL, AIR CORPS,  
DEPUTY COMMANDER FOR OPS.  
ORIGINATOR  
APPROVED, ASSISTANT.

TO: JEPD, JNHL, JCC (SOURCE), JNHR

MAJOR MISSION TOOK OFF AT ZERO EIGHT TWO ONE ZENRA PAREN BAKER AND T IRING INFO  
SPANT: GHA DEARE AND WALSH TOP SEC TARE SIN ONE FOUR PAREN ONE FOUR FIVE THREE  
ALIGHTS AIRBORNE



THE MAKING OF AN EXACT COPY OF THIS MESSAGE IS FORBIDDEN. ONLY  
SUCH EXTRACTS AS ARE ABSOLUTELY NECESSARY WILL BE MADE AND PROPERLY  
CLASSIFIED.

0655

HEADQUARTERS  
EASTERN COMMAND  
USSTAF  
OUTGOING MESSAGES

|                |        |
|----------------|--------|
| PRECEDENCE     | URGENT |
| CLASSIFICATION | SECRET |

P. T. CULLEN,  
COLONEL, AIR CORPS,  
DEPUTY COMMANDER FOR OPS.

DATE 28 JULY 1944

APPROVED, ASJIVATT.

SRL NR T-606 TO: JJHL, JJCQ (BOUNCE)

PLEASE ADVISE BY RETURN ~~GAME~~ TARGETS ~~XX~~ PAREN TO BAKER FOR TWINING SIGNED WALSH  
TARE SIX ZERO SIX TOP SEC PAREN ATTACKED ~~XXXXXX~~ BY BOMBERS TWO EIGHT JULY RECON  
PLANE WILL LEAVE FOR ITALY ON BAKER DOG ABLE ~~XXXXXXXX~~ TWO NINE JULY MORNING



THE MAKING OF AN EXACT COPY OF THIS MESSAGE IS FORBIDDEN. ONLY  
SUCH EXTRACTS AS ARE ABSOLUTELY NECESSARY WILL BE MADE AND PROPERLY  
CLASSIFIED.

0 6 5 6

HEADQUARTERS  
EASTERN COMMAND  
USSTAF  
OUTGOING MESSAGE

|                |            |
|----------------|------------|
| PRECEDENCE     |            |
| CLASSIFICATION | SECRET     |
| DATE           | 26 JULY 44 |
| SRL NR         | T-604      |
| TO:            | JJHL       |

F.T. CULLEN  
COL, AG.  
ORIGINATOR FOR OPS  
APPROVED, ADJUTANT.

SOVIETS ADVISE THAT THE OIL REFINERIES AT DRONOBYZ PAREN SEE YOUR  
ROGER SUGAR TWO SIX ONE EIGHT CS NINE NINE FIVE IS CIA THREE THREE  
IN T HT FOUR ZERO THREE PAREN ARE ABOUT TO BE ENCIRCLED AND ARE NOT  
REPEAT NOT TARGETS PAREN RAKER FROM CULLEN SIGNED WALSH TOP SEC  
TARE \_\_\_\_\_ PAREN WE HAVE BEEN UNSUCCESSFUL  
IN SECURING PHOTO COVER ON MAJOR REFINERIES BETWEEN KRAKOW AND  
DRONOBYZ BECAUSE OF WEATHER BUT THESE ARE STILL HIGH PRIORITY FOR  
PHOTO RECON

Approved  
1807  
JUL 28 1944

THE MAKING OF AN EXACT COPY OF THIS MESSAGE IS FORBIDDEN. ONLY  
SUCH EXTRACTS AS ARE ABSOLUTELY NECESSARY WILL BE MADE AND PROPERLY  
CLASSIFIED.

0657

HEADQUARTERS  
EASTERN COMMAND  
USSTAF

OUTGOING MESSAGES

PRECEDENCE URGENT  
CLASSIFICATION

P.T. CULLEN, COL. AS

ORIGIATOR  
DEPUTY CH. WFO.

APPROVED, ASJUTANT.

DATE 27 JULY 64

SRL NR

7 36

TO: JMD WPAATE FOR ATTORNEY

VERY URGENT  
FROM: [Faded]  
SUBJECT: [Faded]  
[Faded text follows, including "FIFTEEN" and "EIGHTY ONE"]



processed by 065576

THE MAKING OF AN EXACT COPY OF THIS MESSAGE IS FORBIDDEN. ONLY SUCH EXTRACTS AS ARE ABSOLUTELY NECESSARY WILL BE MADE AND PROPERLY CLASSIFIED.

0658



HEADQUARTERS  
EASTERN COMMAND  
USSTAF  
OUTGOING MESSAGES

|                |                   |                      |
|----------------|-------------------|----------------------|
| PRECEDENCE     | URGENT            | F.T. CULLEN, COL. AC |
| CLASSIFICATION | <del>SECRET</del> | COMINFUTY CO. OPS.   |
| DATE           | 28 JULY 44        | APPROVED, ASJYANT.   |
| SRL NR         | TO:               |                      |
| T 605          | JMR               |                      |

DEANE FROM CULLEN SGD WALSH PD STARE SIX ZERO FIVE TOP SEC PAREN  
DROOPSNOOT LIGHTNING PROJECT HAS BEEN POSTPONED INDEFINITELY

*Forwards inf. in 1863*



THE MAKING OF AN EXACT COPY OF THIS MESSAGE IS FORBIDDEN. ONLY  
SUCH EXTRACTS AS ARE ABSOLUTELY NECESSARY WILL BE MADE AND PROPERLY  
CLASSIFIED.

7 3 4 8  
0 6 5 9

HEADQUARTERS  
EASTERN COMMAND  
USSTAF

OUTGOING MESSAGES

(5/1/71)  
F.T. GILES, DL. AC

|                |                   |
|----------------|-------------------|
| PRECEDENCE     | PRIORITY          |
| CLASSIFICATION | <del>SECRET</del> |

DATE 27 JULY 44

APPROVED, ASJUTANT.

SRL NR  
JR 1496

TO: ~~SEC~~ MESSAGE CENTER

DID YOU RECEIVE YOUR MESSAGE FROM WASH DC? WASH DC WOULD BE THE BEST PLACE TO CHECK.  
PLEASE ADVISE ME BY AIR MAIL TODAY



THE MAKING OF AN EXACT COPY OF THIS MESSAGE IS FORBIDDEN. ONLY SUCH EXTRACTS AS ARE ABSOLUTELY NECESSARY WILL BE MADE AND PROPERLY CLASSIFIED.

0660

HEADQUARTERS  
EASTERN COMMAND  
USSTAF  
OUTGOING MESSAGES

|                |                   |
|----------------|-------------------|
| PRECEDENCE     | PRIORITY          |
| CLASSIFICATION | <del>SECRET</del> |

General Kessler  
ORIGINATOR

DATE 27 JULY 44

APPROVED, ASJYATY.

SRL NR  
JK 1479

TO: ~~SECRET~~ MESSAGE CENTER

RELAY WIDENING MESSAGE NUMBER UX 61462 TO DEANE FOR WALSH USS MILITARY MISSION  
MOECOM FOR INFORMATION

GROUPED  
MESSAGE CENTER  
EASTERN COMMAND  
U.S. AIR FORCE

JK 1479

THE MAKING OF AN EXACT COPY OF THIS MESSAGE IS FORBIDDEN. ONLY  
SUCH EXTRACTS AS ARE ABSOLUTELY NECESSARY WILL BE MADE AND PROPERLY  
CLASSIFIED.

0661

HEADQUARTERS  
EASTERN COMMAND  
USSTAF  
OUTGOING MESSAGES

|                |                             |
|----------------|-----------------------------|
| PRECEDENCE     |                             |
| CLASSIFICATION | URGENT<br><del>SECRET</del> |

F. T. CULLER  
COL, AC.  
DEPUTY CO FOR OPS  
ORIGINATOR  
APPROVED, ADJUTANT.

DATE 27 July 44

SRL NR TO: JJHL - JJOQ (BOUNCE)

7-589

MASON INTENDS DEPARTING EASTERN COMMAND TWO NINE JULY AT ~~NINE~~ EIGHT ~~NINE~~ ZERO  
ZEBRA CROSSING OUT SOUTH OF CERNAUTI AT ONE ZERO ZERO ZERO ZEBRA WITH APPROXIMATELY  
TWELVE LIGHTNING AND SWEEPING DEBRECZEN DASH KECS KEMET AT ABOUT ONE ONE TWO ZERO  
ENROUTE YOUR BASE PD BAKER FOR TWINING FOR STROTHER FROM WALSH CITE TAKE FIVE  
EIGHT NINE PD REQUEST AISHER

RECORDED  
INDEXED  
JUL 28 1944  
BY 10 10 7

THE MAKING OF AN EXACT COPY OF THIS MESSAGE IS FORBIDDEN. ONLY  
SUCH EXTRACTS AS ARE ABSOLUTELY NECESSARY WILL BE MADE AND PROPERLY  
CLASSIFIED.

0662

*Old*  
 HEADQUARTERS  
 EASTERN COMMAND  
 USSTAF  
 OUTGOING MESSAGES

|                |                   |
|----------------|-------------------|
| PRECEDENCE     | URGENT            |
| CLASSIFICATION | <del>SECRET</del> |

*30000 1400. 1400*  
 P. T. CULLEN,  
 COLONEL, AIR CORPS,  
 DEPUTY COMMANDER FOR OPS.  
 ONSTAF  
 APPROVED, ADJUTANT.

DATE 26 JULY 1944

SRL NR  
 T-579 TO: JJHL, JJC (BOUNCE), JHPD

TAKING OFF FROM EC FOUR SEVEN MUSTANGS PAREN TO RAGER FOR TWING AND STROTHERS  
 INFO SPAATZ FROM WALSH TAKE FIVE SEVEN NINE TOP SECRET PAREN FIVE FIVE LIGHTNING  
 PD EARLY RETURNS EIGHT TWO GROUP NBR NINE FIVE ZERO CMA THREE NIN EIGHT CMA FOUR  
 THREE FIVE PD ONE LIGHTNING LANDED KIROVOGRAD REPORTED SAFE PD LIGHTNING REMAINING  
 SIXTEEN INCLUDING ONE CRASHED SALVAGE AND ONE ROSEUP OVER FIVE DAYS PD NO MUSTANGS  
 REMAINING PD NEW SUBJECT PERLINOV REQUESTS DETAILS OF TODAY'S SUCCESS BY STROTHERS  
 AS SOON AS POSSIBLE PD YOU SHOULD RECEIVE FIVE ONE LIGHTNING AND FOUR SEVEN MUSTANGS  
 HOPEFULLY

RECEIVED  
 AIR CORPS  
 JUNE 27 1944

THE MAKING OF AN EXACT COPY OF THIS MESSAGE IS FORBIDDEN. ONLY  
 SUCH EXTRACTS AS ARE ABSOLUTELY NECESSARY WILL BE MADE AND PROPERLY  
 CLASSIFIED.

0663

HEADQUARTERS  
EASTERN COMMAND  
USSTAF

OUTGOING MESSAGES

|                |        |
|----------------|--------|
| PRECEDENCE     | URGENT |
| CLASSIFICATION | SECRET |

F. T. CULLEN  
COLONEL, AIR STAFF  
DEPUTY CO FOR OPS  
ORIGINATOR

DATE 26 July 1944

APPROVED, ADJUTANT.

SRL NR

TO: JBPD, JJHL (BOUNCE), JMRR

STROTHER ON HIS WAY AT 0823 PD PRN SPAATZ CMA TAKEN BOUNCE TWINING  
#898

CMA DEANE FROM WALSH TARE \_\_\_\_\_ PRN

AIRBORNE WERE FIVE FIVE LIGHTNINGS AND FOUR SEVEN MUSTANGS

UNRECORDED  
CLASSIFIED UNDER EXEC. ORDER 11652  
EXCERPTS SEE 11652  
BY 11/1/54

7-376

THE MAKING OF AN EXACT COPY OF THIS MESSAGE IS FORBIDDEN. ONLY  
SUCH EXTRACTS AS ARE ABSOLUTELY NECESSARY WILL BE MADE AND PROPERLY  
CLASSIFIED.

0664

HEADQUARTERS  
EASTERN COMMAND  
USSTAF

OUTGOING MESSAGES

|                |        |
|----------------|--------|
| PRECEDENCE     | URGENT |
| CLASSIFICATION | SECRET |

F. T. CULLEN  
COLONEL, AIR CORPS  
DEPUTY CO FOR OPS  
ORIGINATOR

DATE 26 July 1944

APPROVED, ASSISTANT.

SRL NR

TO: JBPD, JJHL (BOUNCE), JMRR

STROTHER ON HIS WAY AT 0823 PD PRN SPAATE CMA TAKEN BOUNCE TWINING  
~~#888~~

CMA DEANE FROM WALSH TARE \_\_\_\_\_ PRN

AIRBORNE WERE FIVE FIVE LIGHTNINGS AND FOUR SEVEN MUSTANGS

RECEIVED  
7-26-44  
EXTRACTED UNDER 13526  
EXEMPT SEE 13526

7-376

THE MAKING OF AN EXACT COPY OF THIS MESSAGE IS FORBIDDEN. ONLY  
SUCH EXTRACTS AS ARE ABSOLUTELY NECESSARY WILL BE MADE AND PROPERLY  
CLASSIFIED.

0665



Relay to Moscow and  
 consents on 1779

HEADQUARTERS  
 EASTERN COMMAND  
 USSTAF

OUTGOING MESSAGE

|                |  |
|----------------|--|
| PRECEDENCE     |  |
| CLASSIFICATION |  |

ORIGINATOR *LAP*

DATE

APPROVED, ASJYATY.

SRL NR

TO:

Relay Spoutz - U-15427

THE MAKING OF AN EXACT COPY OF THIS MESSAGE IS FORBIDDEN. ONLY  
 SUCH EXTRACTS AS ARE ABSOLUTELY NECESSARY WILL BE MADE AND PROPERLY  
 CLASSIFIED.

0666

HEADQUARTERS  
EASTERN COMMAND  
USSTAF  
OUTGOING MESSAGES

|                |                   |
|----------------|-------------------|
| PRECEDENCE     | IMMEDIATE         |
| CLASSIFICATION | <del>SECRET</del> |
| DATE           | 25 JULY 1944      |

P. T. GILLEN,  
COLONEL, AIR CORPS,  
DEPUTY COMMANDER FOR OPS,  
ORIGINATOR

APPROVED, ADJUTANT.

|                                     |         |
|-------------------------------------|---------|
| SRL NR<br>7-372<br><del>7-452</del> | TO: JRD |
|-------------------------------------|---------|

STROTHER CLEARING FOR ITALY JULY TWO SIX AFTER TWO VERY SUCCESSFUL MESSAGES TO BEURAD  
UNCLE SIX FIVE TWO EIGHT SEVEN INFORMATION IS DESIRED CONCERNING THE TWO FIGHTER  
GROUPS MENTIONED AS STROTHER FAWN SPAATZ FROM GILLEN SIGNED WALSH TAG ~~FORM-FIVE~~  
TWO TOP SECRET FAWN LIGHTNING MECHANICS LEAVING FOR ITALY JULY TWO SEVEN BY VIA  
THERAN

THE MAKING OF AN EXACT COPY OF THIS MESSAGE IS FORBIDDEN. ONLY  
SUCH EXTRACTS AS ARE ABSOLUTELY NECESSARY WILL BE MADE AND PROPERLY  
CLASSIFIED.

7 5 5 0  
0 6 6 7

~~SECRET~~  
(PARAPHRASE)

PRIORITY: URGENT

ORIGINATOR: . T. COLLEN

CLASSIFICATION: ~~SECRET~~

25 JULY 1964

TO: DEANE

NO. T-66

~~The first part of~~ THE FIRST PART OF THE MESSAGE IS FROM U65287 FROM SPAATZ.  
THE FEELING HERE IS THAT APPROVAL OF FUTURE PLANS WILL BE IN THE AFFIRMATIVE.  
THEY ARE PROCEEDING WITH PLANNING AND ACTION TO IMPLEMENT THE WHOLE PLAN. HE STATES  
THAT HE WILL NEED THE INCREASED SUPPLY LEVEL FOR READINESS BY THE FIRST OF OCTOBER.  
IT WILL BE NECESSARY WHEN BASES ARE TO BE MOVED, DUE TO THE DOUBLED NUMBER OF FIELDS  
SHUTTLE MISSION WILL CONTINUE TO BE EFFECTIVE AND DEPENDS ON THE WEATHER AND YOUR  
SUPPLIES. HE BELIEVES THAT A SMALL FORCE OF HEAVIES COULD BE DISPERSED ENOUGH FOR  
PROTECTION. DO YOU AGREE? HIGHLY DESIRABLE TO USE BOMBERS FOR SHUTTLE IN EARLY  
AUGUST POSSIBLY GOOD IDEA TO USE TWO FIGHTER GROUPS ONE COULD BE BOMBER PROFICIENT.

PART TWO

A SUCCESSFUL MISSION WAS COMPLETED TODAY AND THEY WILL LEAVE FROM HERE TOMORROW.  
AGREE THAT DISPERSAL IS SUFFICIENT FOR PROTECTION. ALSO MEND THAT THE NEXT MISSION  
ONE CAN. AMMUNITION MUST BE SHIPPED BY AIR. HICKAM HAS PUT IN A RADIO FOR  
FIGHTER BOMBER SUPPLIES ALREADY.



0668



*All* HEADQUARTERS  
EASTERN COMMAND  
USSTAF  
OUTGOING MESSAGES

F.T. CULLEN, COL., A.C.

|                |         |                              |
|----------------|---------|------------------------------|
| PRECEDENCE     | URGENT  | DEPUTY CO FOR OPS            |
| CLASSIFICATION | SECRET  | ORIGINATOR                   |
| DATE           | JULY 25 | APPROVED, ADJUTANT.          |
| SRL NR         |         |                              |
| T-559          | TO:     | JBD, JJHL, JJCQ(BOUNCE), JRR |

AIRBORNE FOR MIELEC STRAFING MISSION AND PAREN TO SPAATZCMA BAKER CMA TWINING CMA  
AND DEANE SGT WALSH TAKE FIVE FIVE NINE PAREN THREE EIGHT PETER THREE EIGHTS AND  
THREE FIVE PETER FIVE ONE-S AT ZERO SEVEN FIVE ZERO ZEBRA TODAY



THE MAKING OF AN EXACT COPY OF THIS MESSAGE IS FORBIDDEN. ONLY  
SUCH EXTRACTS AS ARE ABSOLUTELY NECESSARY WILL BE MADE AND PROPERLY  
CLASSIFIED.

0670

HEADQUARTERS  
EASTERN COMMAND  
USSTAF  
OUTGOING MESSAGE

|                |        |
|----------------|--------|
| PRECEDENCE     | URGENT |
| CLASSIFICATION | SECRET |

P. J. CULLEN, COL., A.C.

DEPUTY CD FOR OPS  
ORIGINATOR

DATE JULY 25

APPROVED, ASSISTANT.

SRL NR

T-558

TO:

JJHL, JHPD(INFO)

HIGHBALL ONE TWO CLEARANCE IN RUSSIAN HANDS PAREN EASER FOR POLIFKA INFO SPAATZ  
SCD WALSH TAKE FIVE FIVE EIGHT PAREN UNLESS WE NOTIFY OTHERWISE BRING HIM ON PD  
PINK GMA HIGHBALL ONE SEVEN GMA PETER THREE EIGHT NBR TWO EIGHT SIX AIRBORNE TO  
YOU AT ZERO FIVE ZERO ZERO ZEBRA PD REURAD PETER WILLIAM ROGER SEVEN FOUR FOUR  
CHARLIE GS PD BRING HIGH BALL ONE TWO IN THROUGH TIRADAPOL SAME TIMES



THE MAKING OF AN EXACT COPY OF THIS MESSAGE IS FORBIDDEN. ONLY  
SUCH EXTRACTS AS ARE ABSOLUTELY NECESSARY WILL BE MADE AND PROPERLY  
CLASSIFIED.

0671

PARAPHRASE

~~Routine~~

25 July 1944

D/C for Oper.

JK 1414 Deane for Walsh from Cullen

Your M 20277 is understood

JK 1414



0672



(PARAPHRASE)

PRECEDENCE: URGENT

CLASSIFICATION: ~~SECRET~~

TO: DEAVE FOR WALSH FROM CULLEN

~~SECRET~~

ORIGINATOR: P. T. CULLEN

24 JULY 1944

NO. T-546

~~XXXXXXXXXXXXXXXXXXXX~~ THERE WAS NO MISSION ON 23 OR 24 BECAUSE OF BAD WEATHER. THERE WERE THREE PHOTO SORTING HUGHES DID NOT RETURN BUT GOT ~~DOWN~~ DOWN AT CHERNIYV. THIS MESSAGE IS A ROUNDUP OF ACTION IN THE PAST TWO DAYS. PLANS WERE DISPATCHED TO SIX FIRMS AND ALL WERE USABLE. CHARLIE, PLANS A, B, AND C SUBMITTED TO THE SOVIETS FOR THE 25 JULY. WILL NOTIFY YOU OF MISSION SELECTED. COMMUNICATIONS WITH MOSCOW DID NOT ANSWER ALTHOUGH CALLED AT FREQUENT INTERVALS THROUGHOUT THE DAY. THE DIFFICULTY SEEMS TO BE WITH RTT NO CONTACT WITH JWHL EVEN THOUGH EQUIPMENT IS OK EXCEPT FOR A TWO HOUR PERIOD. WE HAVE AN URGENT NEED FOR RADIO PERSONNEL. THERE ARE NOW AT TEHRAN NINE MEN TO OPERATE AT THREE DISPERSAL STATIONS PARTICULARLY UNDER FAVORABLE WEATHER AND OPERATING CONDITIONS. THEY HAVE BEEN INSTRUCTED TO SHIP THEM TO POLTAVA. AN AUTHORIZATION HAS BEEN RECEIVED TO RETAIN FIVE LIGHTNING MECHANIC FOR THIRTY DAYS. VINCENT AND LORD HAVE ARRIVED. THERE ARE VACANCIES EXISTING AND NOT A SUFFICIENT NUMBER OF UNOBLIGATED VISAS FOR PERSONNEL NOW IN ROUTE. RECOMMEND FOUR SIX VISAS BE OBTAINED PRIOR TO THE FIRST OF AUGUST. LET US KNOW WHEN THE SPECIAL GROUP VISA IS OBTAINED, FOR KERR'S PARTY SO THAT OBLIGATED VISAS MAY BE USED. RECOMMEND THAT PERSONNEL BE INCREASED TO CARE FOR TWO MECHANICS THAT ARE COMING IN, THEY COME ON THE BULZ BOMB PROJECT. COL, HICRAM IS INTERESTED TO LEARN THE TYPE OF AIRCRAFT SELECTED TO USE ON DOLLY PROJECT. RECOMMEND THAT CENTRAL OFFICE MENTIONED IN WAGP 69020 BE ESTABLISHED IN POLTAVA WITHOUT DELAY. ALL REQUISITIONS FROM THE US TO THE USMILMIS SHOULD BE ROUTED THROUGH POLTAVA. RECOMMEND THAT A MINIMUM OF 30 TONS BE SET PD THE TONNAGE ALLOTTED INADEQUATE IN THE FACE OF 75 TONS NOW REQUESTED FOR MOBILE RED LINES. THIS FIGURE MAY DEPEND ON CURRENT NEGOTIATIONS.

REGRADER  
ORDER RED WORK  
BY TAG/SSM 70

T 546

0673

HEADQUARTERS  
EASTERN COMMAND  
USSTAF  
OUTGOING MESSAGES

P.T. CULLEN, COL., A.C.

PRECEDENCE URGENT  
CLASSIFICATION ~~SECRET~~

DEPUTY CO FOR OPS  
INITIATOR

DATE JULY 24

APPROVED, ADJUTANT.

SRL NR

T-540

TO:

JRFD, JJHL, JJCC (BOUNCE)

SCRUBBED BY WEATHER WAS TODAY'S MISSION PD TO SPAATZ CMA BAKER AND TWINING FROM  
OWLENN-600 WALSH TOPSEC TAKE FIVE FOUR ZERO PD INTEND TO HIT MIELEC TWO FIVE JULY  
AND ON TWO SIX JULY RETURN TO ITALY



T 540

THE MAKING OF AN EXACT COPY OF THIS MESSAGE IS FORBIDDEN. ONLY  
SUCH EXTRACTS AS ARE ABSOLUTELY NECESSARY WILL BE MADE AND PROPERLY  
CLASSIFIED.

0674

HEADQUARTERS  
EASTERN COMMAND  
USSTAF  
OUTGOING MESSAGE

PRECEDENCE URGENT  
CLASSIFICATION ~~SECRET~~

P. T. CULLEN, COLONEL, AG

DEPUTY COMMANDER FOR OPS.  
ORIGINATOR

DATE 23 JULY, 1944

APPROVED, ADJUTANT.

SRL WR  
T-536

TO: JHL JJC(BOUNCE) JPPD

INTENTIONS FOR JULY TWO FOUR COLON LOW ALTITUDE FIGHTER SWEEP OF GALATZ DASH ZILISTRA  
DASH TECUCI DASH BUZAU AREA PD PAREN BAKER FOR TRAINING FROM STROTHER SGT WALSH TOPSEC  
TAKE FIVE THREE SIX PAREN AS WEATHER FORECAST IS FAVORABLE FOR JULY TWO FIVE CMA WE  
INTEND TO STRIKE MILEAC ON THAT DATE THEN RETURN TO ITALY THE NEXT DAY



T. 536

THE MAKING OF AN EXACT COPY OF THIS MESSAGE IS FORBIDDEN. ONLY  
SUCH EXTRACTS AS ARE ABSOLUTELY NECESSARY WILL BE MADE AND PROPERLY  
CLASSIFIED.

0675

HEADQUARTERS  
EASTERN COMMAND  
USSTAF  
OUTGOING MESSAGES

|                |                   |
|----------------|-------------------|
| PRECEDENCE     | URGENT            |
| CLASSIFICATION | <del>SECRET</del> |

P. T. CHANE,  
COLONEL, AIR CORPS,  
~~DEPUTY CHIEF OF STAFF FOR OPS.~~  
OFFICER

DATE 23 JULY 1964

APPROVED, ADJUTANT.

SRL NR  
T-530

TO: JJHL, JJCQ (BO NUB)

YOUR ANSWER TO WILLIAM TWO SIX ITEM EAST FORTY SEVEN MUSTANGS CMA SIXTY SEVEN  
LIGHTNINGS SAFELY ARRIVED PD PAREN TO BAKER AND TWINING FROM WALSH TAKE FIVE THREE  
ZERO TOP SECRET PAREN TWO LIGHTNINGS LOST AND THREE LIGHTNINGS KNOWN TO BE MISSING  
HOWEVER FIGURES OF AIRCRAFT DISPATCHED CONFLICT PD REQUEST CLARIFICATION



THE MAKING OF AN EXACT COPY OF THIS MESSAGE IS FORBIDDEN. ONLY  
SUCH EXTRACTS AS ARE ABSOLUTELY NECESSARY WILL BE MADE AND PROPERLY  
CLASSIFIED.

T 530

0676

HEADQUARTERS  
EASTERN COMMAND  
USSTAF  
OUTGOING MESSAGES

|                |                   |
|----------------|-------------------|
| PRECEDENCE     | URGENT            |
| CLASSIFICATION | <del>SECRET</del> |

P. T. OLLIVY,  
COLONEL, AIR CORPS,  
DEPUTY COMMANDER FOR OPS.

DATE 23 JULY 1944

APPROVED, ADJUTANT.

SRL NR  
T-527

TO: ~~XXXX~~ JJCQ (BOUNCE)

SINCE OUR TASK FIVE TWO TWO THE SOVIETS HAVE REQUESTED THAT MIELEC BE HIT WITHIN  
THREE DAYS PD PAREN BAKER FOR TRAINING FROM STROTHER SIGNED WALSH TASK FIVE TWO  
SEVEN T P SECRET PAREN. WEATHER FORECAST FOR SAME PERIOD UNFAVORABLE AT ALL WORKING  
OUT PLAN FOR REFUELING AT FIELD BETWEEN KIEV AND FRONT LINES AND PROPOSE LOW  
ALTITUDE MISSION IF WEATHER CONDITIONS WARRANT



THE MAKING OF AN EXACT COPY OF THIS MESSAGE IS FORBIDDEN. ONLY  
SUCH EXTRACTS AS ARE ABSOLUTELY NECESSARY WILL BE MADE AND PROPERLY  
CLASSIFIED.

0677

HEADQUARTERS  
EASTERN COMMAND  
USSTAF

OUTGOING MESSAGE

*copy of file*  
P. T. CULLAN,  
COLONEL, AIR CORPS,  
DEPUTY COMMANDER FOR OPS.

|                                   |                   |                   |                     |
|-----------------------------------|-------------------|-------------------|---------------------|
| PRECEDENCE                        | <del>URGENT</del> | <del>SECRET</del> |                     |
| CLASSIFICATION                    |                   | <del>SECRET</del> | ORIGINATOR          |
| DATE                              | 23 JULY 1944      |                   | APPROVED, ADJUTANT. |
| CO 31 ST FIGHTER GROUP (PIRYATIN) |                   |                   |                     |

SRL NR  
1529

TO: BOM

NO MISSION FOR TODAY PAREN TO REEHER FOR CO THREE ONE FIGHTER GROUP FROM STROTHER  
SIGNED WALSH TAKE FIVE TWO NINE TOP SECRET PAREN SUGGEST YOU BE HERE AT ONE SEVEN  
ZERO ZERO FOR PLANNING MISSION FOR TOMORROW

~~SIGNED WALSH~~



THE MAKING OF AN EXACT COPY OF THIS MESSAGE IS FORBIDDEN. ONLY  
SUCH EXTRACTS AS ARE ABSOLUTELY NECESSARY WILL BE MADE AND PROPERLY  
CLASSIFIED.

*W* **SECRET**

(PAR 1-1.1.1)

REFERENCE: URGENT

ORIGINATOR: P. T. O'NEIL

CLASSIFICATION: ~~SECRET~~

20 JULY 1964

TO: CG 31 ST FIGHTER GROUP  
(PRIORITY)

NO. T-526

Keep for aircraft on the alert for daylight hours. Stand by also for pending mission.

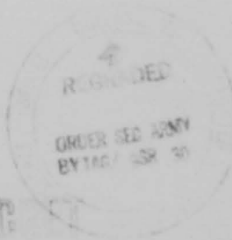

~~SECRET~~

T 526

0679



URGENT

~~SECRET~~ SECRET

23 July 1944

*Submitted by Col. Cullen*  
COL CULLEN

OPERATIONS

*let B*

JJHL, JJCR (BOUNCE)

Tt-

ANSWERING YOUR ITEM RABY ONE THREE FIVE THREE NAN TARE PAREN WAKER  
FOR TWINING FROM WALSH TOP SECRET TARE FIVE TWO THREE PAREN  
SIX SEVEN LIGHTNINGS AND FOUR SEVEN RPT FOUR SEVEN MUSTANGS  
LANDED EASTERN COMMAND BASES LOSSES ESTIMATED HERE FIVE MISSING  
LIGHTNINGS PD WHAT IS CORRECTED TOTAL OF AIRCRAFT DISPATCHED QUERY

ANSWERING ~~SECRET~~ NT

1523

0680

URGENT

GENERAL STROTHERS

~~SECRET~~

23 July 1944

TODAYS HEAVY RAINS AFTER SEVERAL DAYS OF RAIN HAVE LIMITED USEFULNESS OF  
DISPERSAL AIRDROPPES PARACH TO EAKER BOUNCE TRINING FROM STROTHERS SIGNED  
WALSH CITE TARE FIVE TWO TWO PARACH POOR  
WEATHER FORECASTED FOR MISLEAC AREA FOR THREE DAYS PD RECOMMEND TASK  
FORCE RETURN TO ITALY JULY TWO THREE COMPLETING LOW ALTITUDE SWEEP OF  
BUCAREST AREA ENROUTE PD PLEASE EXPEDITE REPLY

*answer to  
U 35610*

T 522  
RECORDED  
INDEXED  
SERIALIZED  
FILED

0681

HEADQUARTERS  
EASTERN COMMAND  
USSTAF  
OUTGOING MESSAGES

|                |                   |
|----------------|-------------------|
| PRECEDENCE     | Urgent            |
| CLASSIFICATION | <del>Secret</del> |

P. T. Cullen, Colonel, AC

Deputy Commander for Ops.  
ORIGINATOR

DATE 22 July, 1944

APPROVED, ADJUTANT.

SRL NR  
T-517

TO: COAAF 560 COAAF 561

EXPECT PLANES TO RETURN PAREN CALLAHAN AND REECHER FROM WALSH TOPSEC  
TARE FIVE ONE SEVEN PAREN ZERO SIX ZERO ZERO LOCAL FOR ONE ZERO THREE  
ZERO LOCAL TAKE OFF ON EAST DASH EAST MISSION TWO THREE JULY ROGER



T-517

THE MAKING OF AN EXACT COPY OF THIS MESSAGE IS FORBIDDEN. ONLY  
SUCH EXTRACTS AS ARE ABSOLUTELY NECESSARY WILL BE MADE AND PROPERLY  
CLASSIFIED.

0682

URGENT

P T CULLEN

COLONEL AIR CORPS

~~SECRET~~

22 July 1944

JRFD, JJHL, JJCQ (BOUNCE)

PROPOSE TO RUN MISSION TWO THREE JULY PD SPAATZ INFO BAKER CMA TWINING  
FROM SIOTHER AND WALSH CITE TAKE FIVE ONE FIVE PD PLAN ABLE STRAFE WIELEO  
AND RETURN ESCOM PD WEATHER FORECAST LOW AND MIDDLE CLOUD FOR NEXT THREE  
DAYS PD PLAN BAKER STRAFE GALATZ CMA FOSSINI AND TROUCI OR CORRESPONDING  
TARGETS THIS AREA DEPENDING INFORMATION PRU TODAY AND CONTINUE TO ITALY PD  
RECOMMEND TASK FORCE TO RETURN IN FOUR OR FIVE DAYS WHEN GENERAL WEATHER  
IMPROVES PD ALTERNATE IS TO RETURN TO RUSSIAN BASES PD HEAVY SHOWERS TODAY  
AFTER SEVERAL DAYS OF PRECIPITATION HAVE REDUCED USABILITY OF MAIN AND  
DEPLOYMENT FIELDS PD EXPEDITE REPLY

~~SECRET~~

T-515



0683

~~SECRET~~  
~~SECRET~~

COL CULLER, GFS

21 July 44

Top x

US MILITARY MISSION

RELAY MESSAGE FROM SPAATZ NBR U-65182 to Gen Deane, CG, US MILITARY  
MISSION, MOSCOW, USSR FOR ACTION



RELAY OF U-65182

0684

cc: Col. Cullen

Gen Walsh

Routine

~~SECRET~~

JULY 21, 1944

HQ USSTAF

JK-1365

SUPPLEMENTING OUR UK ONE THREE FOUR FOUR AND WITH REF YOUR UNCLE SIX FIVE ZERO  
FOUR ONE QUOTE REF OPINION AND THAT DEANE IS OPTIMISTIC AND T OTHER AGENCIES  
REACTION REQUESTED UNQUOTE MY OPINION IS DEANE IS OVER OPTIMISTIC ON MATTER  
OF SECURING IMMEDIATE REPEAT IMMEDIATE APPROVAL PD EVENTUAL APPROVAL  
PROBABLY AFFIRMATIVE PD DEANE HAS ASKED FOR DEFINITE YES OR NO DECISION  
PRIOR HIS DEPARTURE JULY TWO THREE PD IF THIS NOT FORTHCOMING THEN IT PROBABLY  
MAY BE AT LEAST THREE OR FOUR WEEKS BEFORE EVENTUAL APPROVAL GIVEN PD CRITICAL  
TIME IS NOW AND CRITICAL POINT WITH US IS MOVEMENT OF BASES WESTWARD PD DUE  
TO DELAY PLANS MAY HAVE TO BE AGAIN REVISED WITH IDEA OF USING PART OF FALL  
PERIOD FOR READJUSTMENT AND CONSTRUCTING NEW BASES TO WESTWARD OR REDUCING  
OR RESTRICTING OPERATIONS DURING FALL PERIOD BUT UNTIL THEN OPERATING AT A  
MAXIMUM PD PRIOR SEPT ONE FIVE WE SHOULD HAVE MAXIMUM OPERATION FROM PRESENT  
BASES OUR DEFENSE DEPENDING ON DEPLOYMENT AND DISPERSION PD SUPPLIES AND  
PERSONNEL DESIGNATED FRANTIC PROJECT SHOULD CONTINUE TO BE ASSEMBLED AND THEN  
CAN BE FORWARDED AS OPPORTUNITY IS AVAILABLE EITHER THROUGH WERBAUSEK OR PGC



0685

cc: Col. Cullen

Gen Walsh

PRIORITY

~~SECRET~~

21 July 1944

HQ USSTAF

AS RUSSIAN ADVANCE INDICATES CMA CLOSER COORDINATION WILL NOW BE NECESSARY TO  
AVOID RUSSIAN INTERFERENCE WITH OPERATIONS FROM <sup>ALLIED</sup> OTHER AIR FORCES PD THIS MATTER  
TAKEN UP WITH GEN PERMINOV HERE LAST NIGHT PD WE INDICATED DESIRE TO EFFECT  
THAT COORDINATION THROUGH OPERATIONS AGENCIES AT ESCOM PAREN TO SPAATE FROM  
WALSH CITY PAREN BELIEVE THIS  
PROCEDURE HAS PREVIOUSLY BEEN ACCEPTED IN MOSCOW BY RUSSIANS AND AS A  
PRELIMINARY STAGE WE SHOULD ESTABLISH A BOMB LINE ONE HUNDRED MILES WEST OF  
RUSSIAN FRONT PD ESCOM WILL SEND TO YOU AND TO EAKER AT APPROXIMATELY NOON  
EACH DAY CHANGES IN THE RUSSIAN LINE SUMMARIZING PERIODICALLY AT LEAST ONCE  
A WEEK THE ENTIRE LINE PD WHERE NO CONFLICT OCCURS UNDERSTAND OPERATIONS WILL  
PROCEED WITHOUT NOTICE PD ANY OPERATIONS CONTEMPLATED BY OUR AIR FORCES IN  
IMMEDIATE VICINITY OF THIS ONE HUNDRED LINE HOWEVER CMA WE SHOULD NOTIFY  
THE SOVIETS THROUGH ESCOM PD RUSSIAN STRATEGIC AIR FORCE OPERATES PRIMARILY AT  
NIGHT AND THIS TYPE OPERATION WILL INVOLVE CLOSE COORDINATION WHERE POSSIBILITY  
OF CONFLICT MAY EXIST

J K - 1363



0686



HEADQUARTERS  
 GAF FORM NO. 39-A  
 REVISED 7-1-42

ARMY AIRWAYS COMMUNICATIONS SYSTEM  
 MESSAGE FORM (Originator)

|   |                        |   |                                     |
|---|------------------------|---|-------------------------------------|
| The transmission of the following message is authorized.<br>By order of the C.O. (Signature of Authorized originator) |                        | P. F. GULLEN, COLONEL, AIR CORPS<br>DEPUTY COMMANDER POW OPS. |                                     |
| CRYPTO SECTION ACTION   | MESSAGE CENTER RECEIPT | ORIGINATOR  | P. F. GULLEN                        |
| SENT <input type="checkbox"/> SECRET  |                        | DATE  | 21 JULY 1944                        |
| IN <input type="checkbox"/> CONFIDENTIAL <input type="checkbox"/> CODE  |                        | CLASSIFICATION  |                                     |
| <input type="checkbox"/> RESTRICTED   | ROUTING                | TOP SECRET <input checked="" type="checkbox"/>                | RESTRICTED <input type="checkbox"/> |
| CRYPTOGRAPHY BY   |                        | CONFIDENTIAL <input type="checkbox"/>                         | CLEAR <input type="checkbox"/>      |
| DATE-TIME   |                        |   |                                     |
| MESSAGE NUMBER  | ACTION                 | PRECEDENCE  |                                     |
| T-502   | INFORMATION            | OPS. PRIORITY   |                                     |
|   | JSPD                   |   |                                     |

PERSONNALLY FAMILIAR WITH PROJECT PRIOR DEPARTURE MOSCOW RE UNCLY SIX  
 FIVE TWO THREE ZERO PD THOSE IMMEDIATELY CONCERNED ARE ALERTED PD PAREN  
 SPAATZ FROM WALSH TOP SECRET PAREN FIVE ZERO TWO PAREN ANTICIPATE NO RPT  
 NO DIFFICULTY WITH SOVIET OVER OPERATION OF DROOPSNOOT LIGHTNINGS PD  
 HOSTILE REACTION ON BOTH SIDES OF FRONT FROM ENEMY AND SOVIET MAY BE  
 EXPECTED CMA BUT SOVIET NOT RPT NOT A DETERRENT PD AS YOU KNOW ONLY RPT  
 ONLY <sup>FIVE</sup> LIGHTNING MECHANICS ARE A SIGNED EASCOM CMA WAY WE RETAIN FIVE  
 LIGHTNING MECHANICS TEMPORARILY HERE FROM FIFTEENTH AIR FORCE QUERY



THE SECURITY OF THIS MESSAGE WILL BE SAFEGUARDED ACCORDING TO AR380-5-40, 41, 42.

U. S. GOVERNMENT PRINTING OFFICE: 1943 O - 534800

0687

WAR DEPARTMENT  
 AIR FORM NO. 24-A  
 REVISED 7-1-44

ARMY AIRWAYS COMMUNICATIONS SYSTEM  
 MESSAGE FORM (Originator)

|   |  |   |
|---|--|---|
| The transmission of the following message is authorized by order of the C.O. (Signature of Authorized originator) <b>P. T. Cullen, Colonel, Air Corps<br/>Deputy Commander for Operations</b> |  | ORIGINATOR<br><b>P. T. Cullen</b>   |
| CRYPTO SECTION ACTION   | MESSAGE CENTER RECEIPT                               | DATE<br><b>21 July, 1944</b>  |
| SECRET <input type="checkbox"/><br>CONFIDENTIAL <input type="checkbox"/><br>IN RESTRICTED <input type="checkbox"/>  | ROUTING  | CLASSIFICATION<br><b>TOP SECRET</b> <input checked="" type="checkbox"/> RESTRICTED <input type="checkbox"/><br>CONFIDENTIAL <input type="checkbox"/> CLEAR <input type="checkbox"/> |
| CRYPTOGRAPHY BY   |  |   |
| DATE/TIME   |  |   |
| MESSAGE NUMBER<br><b>T-500</b>  | ADDRESSEES<br>ACTION<br><b>JBPD JJHL JJQ(Bounce)</b> | PRECEDENCE<br><b>Urgent</b>   |

NOTIFICATION HAS BEEN GIVEN TO SOVIET AND TO DEANE OF PRANTIC THREE WITH  
 HOUR AT ZERO EIGHT ONE FIVE ZEBRA PAREN TO SPAATZ AND TO EAKER FOR TWINING  
 AND POLIPKA FROM WALSH TOP SECRET TARE FIVE ZERO ZERO PAREN THIS ACKNOWLEDGES  
 CHARLIE SUGAR EIGHT SIX FIVE ITEM EASY LOVE WILLIAM TWO FOUR CMA ITEM OBOE  
 ONE THREE THREE EIGHT CMA JIG ITEM EASY ONE THREE FOUR ONE NAN TARE CHARLIE  
 SUGAR ONE ZERO SEVEN ONE NAN TARE JIG DOG YOKE ONE EIGHT NINE NAN TARE FOX  
 ABLE FOX EASY EIGHT FIVE ZERO ONE CMA JIG KING ONE FOUR FOUR ITEM EASY PD  
 IN ADDITION TO OTHER TWO SET UP IN YOUR CHARLIE SUGAR EIGHT SIX FIVE ITEM  
 EASY CMA CHAPMAN PAREN HIGHBALL FIVE FIVE PAREN WILL FLY BOMB DAMAGE PHOTO  
 AND GO TO ITALY



T 500

THE SECURITY OF THIS MESSAGE WILL BE SAFEGUARDED ACCORDING TO AR380-5-40, 41, 42.

U. S. GOVERNMENT PRINTING OFFICE: 1943 O - 539900

0688

ARMY DEPARTMENT  
 AIR FORM NO. 20-A  
 REVISED 7-1-42

ARMY AIRWAYS COMMUNICATIONS SYSTEM  
 MESSAGE FORM (Originator)

|  |  |            |
|--|--|------------|
| The transmission of the following message is authorized. P. T. Cullen, Colonel, Air Corps<br>By order of the C.O. (Signature of Authorized originator) Deputy Commander for Operations |  |            |
| CRYPTO SECTION ACTION  | MESSAGE CENTER RECEIPT   |            |
| SECRET <input type="checkbox"/>  |  |            |
| SENT IN CONFIDENTIAL <input type="checkbox"/> CODE   |  |            |
| RESTRICTED <input type="checkbox"/>  | ROUTING  |            |
| CRYPTOGRAPHY BY  | ORIGINATOR<br>P. T. Cullen   |            |
| DATE/TIME  | DATE<br>21 July, 1944  |            |
|  | CLASSIFICATION<br>Top SECRET <input checked="" type="checkbox"/> RESTRICTED <input type="checkbox"/> |            |
|  | CONFIDENTIAL <input type="checkbox"/> CLEAR <input type="checkbox"/>                                 |            |
| MESSAGE NUMBER   | ACTION   | PRECEDENCE |
| T-400  | INFORMATION  | Urgent     |
|  | JMRR   |            |

15th A. F. Frantic Three will be 22 July, 1944. Plan "B" will be used with  
 "H" hour at 0815z. This is paraphrase of JD-14-IE from Baker.



THE SECURITY OF THIS MESSAGE WILL BE SAFEGUARDED ACCORDING TO AR380-5:40, 41, 42.

U. S. GOVERNMENT PRINTING OFFICE 1243 O - 53860

0689

ARMY DEPARTMENT  
 GAT FORM NO. 29-A  
 REVISED 5-1-42

ARMY AIRWAYS COMMUNICATIONS SYSTEM  
 MESSAGE FORM (Originator)

|   |   |  |
|---|---|--|
| The transmission of the following message is authorized. <b>P. T. Cullen, Colonel, Air Corps</b><br>By order of the C.O. (Signature of Authorized originator): <b>Deputy Commander for Operations</b> |   | ORIGINATOR<br><b>P. T. Cullen</b>  |
| CRYPTO SECTION ACTION   | MESSAGE CENTER RECEIPT  | DATE<br><b>21 July, 1944</b>   |
| SECRET <input type="checkbox"/>   |  | CLASSIFICATION   |
| SENT IN CONFIDENTIAL <input type="checkbox"/> CODE  |   | SECRET <input checked="" type="checkbox"/> RESTRICTED <input type="checkbox"/> |
| RESTRICTED <input type="checkbox"/>   | ROUTING   | CONFIDENTIAL <input type="checkbox"/> CLEAR <input type="checkbox"/>           |
| CRYPTOGRAPHY BY   |   |  |
| DATE/TIME   |   |  |
| MESSAGE NUMBER  | ADDRESSEES  | PRECEDENCE   |
| T- 498  | ACTION  | Urgent   |
|   | INFORMATION   |  |
|   | JJHL JBPD   |  |

IN RUSSIAN HANDS IS YOUR PAREN TAKER FOR POLIFKA INFO SPAATZ FROM WALSH TOP  
 SECRET TARE FOUR NINE EIGHT PAREN CHARLIE MIKE THREE FIVE FIVE PD NO WORD RM  
 FROM US MEANS LET HIM COME ON



THE SECURITY OF THIS MESSAGE WILL BE SAFEGUARDED ACCORDING TO AR380-5-40, 41, 42.

U. S. GOVERNMENT PRINTING OFFICE: 1943 O - 539900

0690

HEADQUARTERS  
ARMY AIRWAYS COMMUNICATIONS SYSTEM  
MESSAGE FORM (Originator)  
REVISED 7-1-42

ARMY AIRWAYS COMMUNICATIONS SYSTEM  
MESSAGE FORM (Originator)

The transmission of the following message is authorized.   
By order of the C.O. (Signature of Authorized originator)

|   |                                       |                        |  |
|---|---------------------------------------|------------------------|--|
| CRYPTO SECTION ACTION                       |                                       | MESSAGE CENTER RECEIPT | ORIGINATOR<br>COL CULLEN   |
| SECRET <input type="checkbox"/>             | CONFIDENTIAL <input type="checkbox"/> | CODE                   | DATE<br>JULY 21  |
| SENT IN RESTRICTED <input type="checkbox"/> |                                       |                        | CLASSIFICATION   |
| CRYPTOGRAPHY BY                             |                                       | ROUTING                | SECRET <input checked="" type="checkbox"/> RESTRICTED <input type="checkbox"/> |
| DATE-TIME                                   |                                       |                        | CONFIDENTIAL <input type="checkbox"/> CLEAR <input type="checkbox"/>           |

|                |             |                  |          |
|----------------|-------------|------------------|----------|
| MESSAGE NUMBER | ADDRESSEES  |                  | PRIORITY |
|                | ACTION      | JJHL BOUNCE JJCL | IP       |
|                | INFORMATION |                  |          |

NOTIFICATION HAS BEEN GIVEN SOVIETS LEONARD ONE ZERO DASH ONE THREE THREE  
EIGHT EAKER FOR TWIRING SOD WALSH CITE TALS FOUR NINE FIVE TOPSEC EXX  
WE ARE READY



T495

THE SECURITY OF THIS MESSAGE WILL BE SAFEGUARDED ACCORDING TO AR380-5:10, 41, 42.

U. S. GOVERNMENT PRINTING OFFICE: 1942 O - 538900

0691

HEADQUARTERS  
EASTERN COMMAND  
USSTAF  
OUTGOING MESSAGE

|                |                       |
|----------------|-----------------------|
| PRECEDENCE     | URGENT                |
| CLASSIFICATION | <del>TOP SECRET</del> |

P. J. CULLEN, COLONEL, AIR COR

DEPUTY COMMANDER FOR OPERATIONS  
ORIGINATOR

DATE 20 JULY, 1944

APPROVED, ASSJYATY.

SRL NR  
T-489

TO: JJHL

WHEN COMING THIS WAY PAREN BAKER FOR POLYVA FROM WALSH TOP SECRET TAKE FOUR EIGHT  
NINE PAREN THE ENTRY GATE TO RUSSIA FOR SINGLE AIRCRAFT WILL BE AAKENMAN PAREN  
TURLACHI PAREN COORDINATES FOUR SIX DEGREES ONE TWO MINUTES NORTH THREE ZERO DEGREES  
TWO ONE MINUTES EAST STARTING ON TWO TWO JULY THIS YEAR



THE MAKING OF AN EXACT COPY OF THIS MESSAGE IS FORBIDDEN. ONLY SUCH EXTRACTS AS ARE ABSOLUTELY NECESSARY WILL BE MADE AND PROPERLY CLASSIFIED.

0692

~~SECRET~~  
PARAPHRASE OF

SECRET ROUTINE

20 July 1944

TO: CG PERSIAN GULF COMMAND

ATTN GRAHAM SIGNED WALSH

~~SECRET~~

REF YOUR RADIO P-16559 OUR PROGRAM HAS NOT YET BEEN GIVEN SOVIET  
SANCTION AND ADVANCES OF RED ARMY MAKE FORWARD MOVEMENT OF BASES NECESSARY PD  
WE STILL WANT THE TG SKEED AND REQUEST YOU HOLD SENDING IT UNTIL FURTHER  
ADVISED





~~SECRET~~

~~TOP~~ SECRET

COL GILLEN  
OPERATIONS

20 July

T 485

ITALY

HAVE INFORMED TO BAKER FOR TWINING FROM WALSH TARE FOUR EIGHT FIVE  
TOP SECRET  
SV IETS OF YOUR ITEM GEORGE ONE THREE THREE ZERO MESSAGE



0694

GEN WALSH

OPERATIONAL RADIO TELETYPE

20 July 1944

HQ USSTAF

PERSONAL FOR SPAATZ FROM WALSH PD RETURNED ESCOM JULY ONE NINE PD RUSSIAN  
 ADVANCES HAVE PRACTICALLY ELIMINATED TARGETS IN BRIST DASH LITOVSK AREA LEAVING AS  
 PRIMARY TARGETS FOR FIGHTER BOMBERS WIELEC AND RADOM IN THIS REGION PD TO AVOID  
 INTERFERENCE WITH RUSSIAN OPERATIONS WE HAVE ESTABLISHED BOMBER LINE APPROXIMATELY  
 ONE HUNDRED MILES WEST OF RUSSIAN FRONT PD FEW MORE TARGETS WILL BE DEVELOPED IN  
 WIELEC RADOM AREA BUT THESE WILL BE LIMITED PD THEN REMAINING TARGETS THOSE GALATZ  
 AREA WHICH LATEST INFORMATION INDICATES HAVE AIRPLANE CONCENTRATIONS PD  
 NEW SUBJECT DURING FIVE DAYS MOSCOW DEANE AND I EMPHASIZED TO SOVIETS IMMEDIATE  
 NECESSITY FOR DECISION PERMITTING ENTRY NIGHT FIGHTERS ANTI AIRCRAFT AND OTHER  
 UNITS IN NIGHT NINE ZERO ZERO PROGRAM PD SOVIET AIR FORCE APPEAR FAVORABLY  
 INCLINED BUT MATTER HAS TO GO TO FOREIGN OFFICE AS INVOLVES MAJOR DECISION PD HAVE  
 ASKED PERMISSION TO RIGHT NOW MAKE SURVEY VIN ITSA AREA AND EXPRESSED PREFERENCE  
 FOR VINNITSA OVER KIEV AREA PD ANY MOVE WEST APPARENTLY ALSO INVOLVED MAJOR  
 DECISION OF FOREIGN OFFICE PD  
 NEW SUBJECT DEANE EXPECTS TO LEAVE FOR UK ON MONDAY PD I INTEND TO RET RN MOSCOW  
 SUNDAY FOR CONFERENCE PRIOR HIS DEPARTURE PD ABSENCE OF DEANE WILL NECESSITATE  
 SPENDING MORE TIME MOSCOW AS PRESENT SITUATION THERE PREFERENCE OUR PROGRAM DEMANDS  
 IT BE WATCHED CLOSELY PD  
 NEW SUBJECT YOU STATED KEERR WOULD BE ESCOM HERE SOMETIME SOON PD HAS ANY DEFINITE  
 DATE BEEN ESTABLISHED QUERY

TOP  
 (page 1 of 2 pages)

0695

GEN WALSH

ROUTINE RADIO TELETYPE  
SECRET

20 JULY 1944

HQ USSTAF

(Page 2 of 2 pages)

new subject communication situation is confused as radios received in MOSCOW  
THAT PRINCIPALLY BELONG ESCOM AND VICE VERSA PD MAIN DIFFICULTY IS INEFFECTIVENESS  
OF COMMUNICATION BETWEEN MOSCOW AND POLTAVA WHICH MAKES COORDINATION DIFFICULT PD  
STILL FEEL THAT SOLUTION TO THIS PROBLEM IS RADIO TELETYPE POLTAVA AND MOSCOW PD  
SUGGEST USSTAF AND MAAF RADIOS TO MOSCOW ALSO BE SENT ESCOM.  
NEW SUBJECT FOR YOUR INFO WE ARE HAVING DIFFICULTIES REFERENCE RATE OF EXCHANGE  
SINCE WAR DEPT HAS EFFECTIVE JULY ONE REDUCED RATE TO FIVE TO ONE NATURALLY  
HAVING BAD EFFECT ON MORALE PD SUBJECT IS BEING HANDLED DIRECTLY BY HARRIMAN  
AND DEANE WITH WASHINGTON PD  
NEW SUBJECT DEANE AND I AGREED ON SUCCESSIVE STEPS FOR DEVELOPMENT FRANTIC  
PROJECT AND HE WILL TALK THIS MATTER OVER WITH YOU

0696

HEADQUARTERS  
EASTERN COMMAND  
USSTAF  
OUTGOING MESSAGES

PRECEDENCE  
CLASSIFICATION Operational Priority  
DATE ~~Secret~~

P. T. Callen, Colonel, A.C.  
ORIGINATOR  
Deputy Commander for Operations  
APPROVED, ADJUTANT.

SRL 19 July, 1944  
TO:  
1-401 JJ0a(Bounce) JJH

NOTIFICATION PAREN BAKER FOR TRAINING FROM WALSH TOP SECRET TARE FOUR EIGHT ONE PAREN  
OF PLAN BAKER FOR JULY TWO ONE HAS BEEN MADE TO SOVIETS

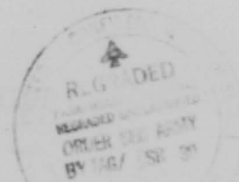

THE MAKING OF AN EXACT COPY OF THIS MESSAGE IS FORBIDDEN. ONLY  
SUCH EXTRACTS AS ARE ABSOLUTELY NECESSARY WILL BE MADE AND PROPERLY  
CLASSIFIED.

0697

HEADQUARTERS  
EASTERN COMMAND  
USSTAT  
OUTGOING MESSAGES

|                |         |                                 |
|----------------|---------|---------------------------------|
| PRECEDENCE     | URGENT  | P.T. CULLEN, COL., A.C.         |
| CLASSIFICATION | SECRET  | DEPUTY CO FOR OPS<br>ORIGINATOR |
| DATE           | JULY 19 | APPROVED, ADJUTANT.             |
| SRL NR         | TO:     |                                 |
| 7-77           | JJHL    |                                 |

FRANTIC MESSAGE HAS NOT REPEAT NOT ARRIVED PD WASH FROM WASH CITY TASK FOUR  
SEVEN SEVEN <sup>CPSE</sup> HAVE RECEIVED NO CANCELLATION PD ADVISE IMMEDIATELY



THE MAKING OF AN EXACT COPY OF THIS MESSAGE IS FORBIDDEN. ONLY  
SUCH EXTRACTS AS ARE ABSOLUTELY NECESSARY WILL BE MADE AND PROPERLY  
CLASSIFIED.

0698

HEADQUARTERS  
EASTERN COMMAND  
USSTAF  
OUTGOING MESSAGES

|                |              |  |
|----------------|--------------|--|
| PRECEDENCE     | URGENT       | P. T. CULLEN,  |
| CLASSIFICATION | SECRET       | COLONEL, AIR CORPS,<br>DEPUTY COMMANDER FOR OPS.<br>ORIGINATOR |
| DATE           | 12 JULY 1964 | APPROVED, ADJUTANT.  |
| SRL NR         | TO:          | JJHL   |
| T-473          |              |  |

WILL YOU TELL US WHICH PLAN WILL BE USED PAREN BAKER FOR TWINING FROM CULLEN  
SIGNED WALSH TAKE FOUR SEVEN THREE TOP SECRET PAREN BUT SOON



THE MAKING OF AN EXACT COPY OF THIS MESSAGE IS FORBIDDEN. ONLY  
SUCH EXTRACTS AS ARE ABSOLUTELY NECESSARY WILL BE MADE AND PROPERLY  
CLASSIFIED.

0699

Argument-automotive Office  
L-RJF/msh  
17 July 1944

48

PARAPHRASE COPY

PRECEDENCE: PRIORITY

CLASSIFICATION: ~~SECRET~~

TO: SPAATZ FOR SUGGESTIONS FROM WALSH

SHOULD WE MAKE PLANS WITH THE RUSSIANS TO GET THEIR DPMO BOMBS USING AS A  
FOUNDATION FOR CALCULATING OUR NEEDS 1600 EACH B-17 SORTIES AND 225 EACH  
P-38 FIGHTER-BOMBER SORTIES? AVAILABLE INFORMATION INDICATES P-38 FIGHTER-  
BOMBERS NOW ABLE TO CARRY 2 DROP TANKS AND 4 BOMBS. DO YOU DESIRE THE USE  
OF ANY BOMB LARGER THAN THE 250 KG



JK 1294

0700



HEADQUARTERS  
EASTERN COMMAND  
USSTAF  
OUTGOING MESSAGES

|                  |                            |   |
|------------------|----------------------------|---|
| PRECEDENCE       | PRIORITY                   | P. 1. FILED                               |
| CLASSIFICATION   | <del>SECRET</del>          | GENERAL, ED WING,<br>DISPATCHED FOR INFO. |
| DATE 17 JUL 1966 |                            | ORIGINATOR                                |
| SRL NR<br>T-462  | TO: <del>SECRET</del> CITE | APPROVED, ADJUTANT.                       |

~~SECRET~~ INFORMATION OF THE UNITED STATES IS TO BE KEPT SECRET UNLESS OTHERWISE INDICATED  
 IN THE MESSAGE OR IN THE ATTACHED DOCUMENTS. THIS MESSAGE IS TO BE KEPT SECRET UNLESS OTHERWISE  
 INDICATED. <sup>NOTE</sup> THIS MESSAGE IS TO BE KEPT SECRET UNLESS OTHERWISE INDICATED.  
 THIS MESSAGE IS TO BE KEPT SECRET UNLESS OTHERWISE INDICATED. THIS MESSAGE IS TO BE KEPT SECRET UNLESS  
 OTHERWISE INDICATED.

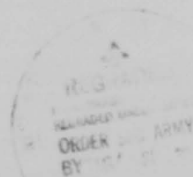

Answer M124836

T-462

THE MAKING OF AN EXACT COPY OF THIS MESSAGE IS FORBIDDEN. ONLY  
 SUCH EXTRACTS AS ARE ABSOLUTELY NECESSARY WILL BE MADE AND PROPERLY  
 CLASSIFIED.

0701

P. T. CULLEN  
COLONEL, AIR CORPS  
DEPUTY CO-POB OPS

~~SECRET~~  
17 July 44

T-453

To CO Sta 560

CO Sta 561

No mission until further notice.



0702

SECRET

P T CULLER  
COL. AIR CORPS  
DEPUTY CO FOR OPERATIONS

16 July 44

JK 1284

JK 1284

JJOC

SOVIETS HAVE BEEN NOTIFIED OF FLIGHT PLAN FOR THE EIGHTIETH PARACHUTE  
BATTALION FOR TRIP TO FREE CULLEN SIGNED WALSH CITE JIG KING ONE TWO EIGHT  
FOUR FIVE THIS ACKNOWLEDGES YOUR CHARLIE SUGAR EIGHT FOUR ONE FIVE EASY  
FOR WILL

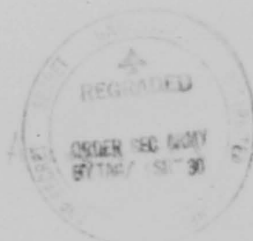

0703



44-1278  
0704

15

15 July 44

COL GULL

JF 1226

Quartermaster, Italy

NO REPORT ON INFORMATION ON MECHANICS AS CHARLIE FOUR SIXES FORGED TOOL  
BE ROUTE FIVE THREE FOR TRAINING FROM GULLER SIGNED WASH CITE SIG 1226  
ONE TWO SIX EIGHT THREE WILL ARE THIRDS PD BE ARE HEADS FOR DESIGN

Handwritten note: I E 7/15/44

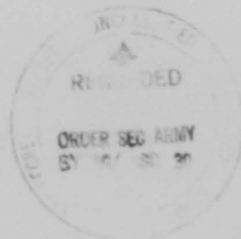

0705

PRECEDENCE: PRIORITY

CLASSIFICATION: ~~SECRET~~

TO: T-1210

FROM: SAPOV J. BOGGS, CAPT.  
CHEMICAL WARFARE DIV.

DATE: 15 JULY, 1944

UNCLAS: JK-1257

MOSCOW STATES THEY WERE TRYING TO PREPARE SO CAL. AMMUNITION IN BELTS  
1 TRACER - 2 AP - 2 API BY CASES. WE HAVE PREPARED AMMUNITION FOR  
10TH AS DIRECTED IN THEIR TAPP-718 2 AP - 2 I - 1 TRACER. GET  
TOGETHER WITH CASES AND INFORM US WHETHER INCIDENTAL OR AP INCIDENTAL  
IS TO BE USED.



JK 1257

0706

PARAPHRASED VERSION

TO : SPAATZ PERSONAL  
FROM : WALSH

JK 1340

LIM/E

C/S

*14 July*

SIMILAR ATTACK TO ONE ON MOLTAVA HAS BEEN REPEATED RECENTLY ON ANOTHER  
AIRFIELD OCCUPIED BY THE RUSSIANS ACCORDING TO INFORMATION JUST RECEIVED.  
WE ARE TAKING SPECIAL PRECAUTIONS TO PROTECT PERSONNEL AND ADDITIONAL  
FIELDS HAVE BEEN OBTAINED FOR DEPLOYMENT OF AIRPLANES DURING HOURS OF  
DARKNESS PD THIS SHOULD PLACE 24 TACTICAL AIRCRAFT ON EACH FIELD.



PARAPHRASED VERSION

0 7 0 7



HEADQUARTERS  
EASTERN COMMAND  
USSTAF  
OUTGOING MESSAGES

|                |               |                     |
|----------------|---------------|---------------------|
| PRECEDENCE     | URGENT        | P. T. CULLEN, COL.  |
| CLASSIFICATION |               | ORIGINATOR          |
| DATE           | 13 JULY, 1944 | APPROVED, ADJUTANT. |
| SRL NR         | TO: JMRR      |                     |

MONETARY SITUATION HAS BECOME ACUTE AND ALARMING PD THEREFORE HAVE  
CLOSED FINANCE AND POST OFFICES AND POST EXCHANGE PD IT IS IMPER-  
ATIVE THAT CORRECTIVE ACTION PAREN DEANE FOR WALSH FROM CULLEN  
JIG KING ONE TWO ONE SIX MARKED TOP SECRET PAREN BE ACCOMPLISHED  
IMMEDIATELY PD EITHER A SERIOUS BREACH IN SOVIET AMERICAN RELATIONS  
WILL RESULT OR THE MORALE OF THE COMMAND WILL HIT ZERO PD BARTER  
OF THE SOLDIERS PERSONAL POSSESSIONS IS RAMPANT AND BEYOND CONTROL  
OF SOVIET PD IT WILL REQUIRE A COMPANY OF MILITARY POLICE FOR EACH  
BASE IF AMERICAN CONTROL IS DESIRED PD IF THE RATE OF EXCHANGE IS  
FIXED AT ABOUT FIFTY RUBBLES FOR THE DOLLAR OR EVEN CLOSER TO ACTUAL  
RUBLE VALUE THEN PRESENT BARTER DIFFICULTIES WILL DIMINISH PARA  
THERE ARE FOUR SOLUTIONS PD ONE CMA CLOSE EASTERN COMMAND PD TWO CMA  
REFUSE TO ACCEPT ROUBLES FOR DOLLARS CMA MONEY TRANSFER OR GOVERN-  
MENT CHECK CMA HOWEVER THIS IS ILLEGAL INASMUCH AS TROOPS ARE PAID  
IN ROUBLES PD THREE CMA MAKE EXCHANGE RATE EQUAL BLACK MARKET RATE  
OF ONE HUNDRED ROUBLES TO THE DOLLAR PD FOUR CMA PAY TROOPS ONLY  
IN DOLLARS OR POUNDS AND LET SOVIET HANDLE EXCHANGE PD THIS SOLUTION  
WILL ELIMINATE BARTER AND EXCHANGE PROBLEMS PD RECOMMEND STRONGLY  
THAT SIXTY THOUSAND DOLLARS IN GOLD SEAL CURRENCY AND COINS BE  
FLOWN TO THIS COMMAND ON HIGHEST PRIORITY FOR THE IMMEDIATE PAY OF  
TROOPS AND FOR THE JULY PAYROLL PARA

THE MAKING OF AN EXACT COPY OF THIS MESSAGE IS FORBIDDEN. ONLY  
SUCH EXTRACTS AS ARE ABSOLUTELY NECESSARY WILL BE MADE AND PROPERLY  
CLASSIFIED.

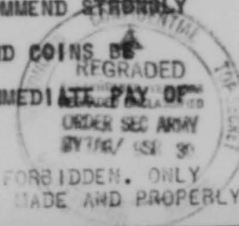

0 7 0 8

HEADQUARTERS  
EASTERN COMMAND  
USSTAF  
INCOMING MESSAGE

|                |            |
|----------------|------------|
| PRECEDENCE     | URGENT     |
| CLASSIFICATION | [REDACTED] |

P.T. CULLEN, COL.

DATE 13 JULY, 1944

SERIAL NR. \_\_\_\_\_

FROM: \_\_\_\_\_

JK-1216

TO: \_\_\_\_\_

JMRR

THIS FUND SHOULD BE IN PROPORTIONATE SMALL DENOMINATIONS FOR THE  
PAYMENT OF ONE THREE ZERO ZERO TROOPS PD PARA AS A RESULT OF  
DEANES RADIO ESTABLISHING FIVE POINT THREE ROUBLES TO THE DOLLAR  
THERE WAS CONVERTED IN THE LAST TWO DAYS FOR TRANSFER TO THE  
US TWO FOUR THOUSAND DOLLARS PD IT IS OBVIOUS THAT THE US  
TREASURY IS SUFFERING A LARGE LOSS PD TREASURY OR DIPLOMATIC  
OBJECTIONS TO THE PAYMENT OF TROOPS IN US CURRENCY MUST BE  
OVERCOME RAPIDLY PD ONCE AGAIN IT IS DESIRED TO IMPRESS WITH  
THE NECESSITY FOR IMMEDIATE ACTION ON THESE RECOMMENDATIONS PD  
AND END



THE MAKING OF AN EXACT COPY OF THIS MESSAGE IS FORBIDDEN. ONLY SUCH  
EXTRACTS AS ARE ABSOLUTELY NECESSARY WILL BE MADE AND PROPERLY  
CLASSIFIED.

0709

HEADQUARTERS  
EASTERN COMMAND  
USAF  
OUTGOING MESSAGES

|                   |              |      |                               |
|-------------------|--------------|------|-------------------------------|
| PRECEDENCE        | URGENT       |      | PTC                           |
| CLASSIFICATION    | SECRET       | COPY | Dep Cmdr for Ops<br>INITIATOR |
| DATE              | 13 July 1944 |      | APPROVED, ADJUTANT.           |
| SRL NR<br>JK 1220 | TO: JMRR     |      |                               |

JUST RECEIVED IS YOUR MIKE TWO ZERO ONE FOUR TWO ARRIVES OPPORTUNELY AFTER THE DISPATCH OF OUR JIG KING ONE TWO ONE SIX DATED ONE THREE JULY PD TO DEANE FOR WALSH FROM CULLEN PD EYE HAVE JUST RETURNED FROM A VISIT WITH KOVALEV TO ONE OF OUR SUPPLY POINTS WHICH WAS LOOTED BY THE SOVIETS PD IT IS EMPHATICALLY STATED THAT THERE CAN BE NO CONTROL BY THE SOVIETS OR OURSELVES OVER THE PROCUREMENT OF RUBLES BY AMERICAN TROOPS AS LONG AS PAYMENT IS MADE IN RUBLES AT SUCH AN UNREALISTIC RATE OF EXCHANGE PD WHEN ONE CIGARETTE RPT ONE EACH CIGARETTE BRINGS FIVE RUBLES IN A WALK THROUGH THE PARK IT IS IMPOSSIBLE RPT IMPOSSIBLE TO CONTROL THE ACQUISITION OF RUBLES UNLESS THESE RUBLES HAVE NO RPT NO DOLLAR VALUE PD THE HIGH SOUNDING SENTIMENTS OF WAR SIX TWO EIGHT SEVEN TWO ARE NOT BASED ON A PRACTICAL SOLUTION PD PLEASE REMEMBER THAT THERE ARE NO RPT NO MILITARY POLICE OR ANY MEANS UNDER AMERICAN CONTROL FOR ENFORCING ANY REGULATIONS REGARDING RESTRICTION TO CAMP OR THE POSTING OF ANY AREAS PD REGULATIONS WITHOUT FORCE ARE MEANINGLESS PD AGAIN REAFFIRM RECOMMENDATION FOR ALL PAYMENTS TO BE MADE IN DOLLARS



THE MAKING OF AN EXACT COPY OF THIS MESSAGE IS FORBIDDEN. ONLY SUCH EXTRACTS AS ARE ABSOLUTELY NECESSARY WILL BE MADE AND PROPERLY CLASSIFIED.

0710

SECRET

PARAPHRASE

PRIORITY: URGENT

ORIGINATOR: COLONEL GULLEY

CLASSIFICATION: ~~SECRET~~

12 JULY 1964

TO: JMWAVE TO BOLIFRA

NO. 7-78

ARRANGE TO FOLLOW FOR INFO APPROVED

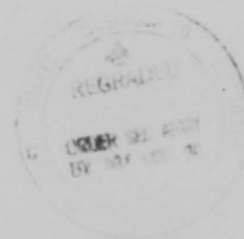

0711

~~SECRET~~ SECRET

UNCLASSIFIED

TOP SECRET

SECRET

THE ATTENTION OF THE DIRECTOR OF THE FBI IS DRAWN TO THE

TARGETS: SYLVAN, PAUL; SYLVAN, DAVID; SYLVAN, EDWARD; SYLVAN, FRANK;

AND TO THE FACT THAT THE ABOVE NAMED INDIVIDUALS ARE

ALL REGISTERED AS MEMBERS OF THE COMMUNIST PARTY, U.S.A.

IT IS REQUESTED THAT YOU BE KEPT ADVISED OF ANY

DEVELOPMENTS IN THIS MATTER.

VERY TRULY YOURS,

J. EDGAR HOOVER

DIRECTOR

ENCLOSURE



0712

(PLAIN LANGUAGE)

PRIORITY: X-15 PRIORITY

ORIGINATOR: FIFTY SEVEN

CLASSIFICATION: [REDACTED]

3 JULY 1944

TO: CAKER FOR WALSH

NO. 1-285

THE CONTENTS OF YOUR B-2000 HAVE BEEN MADE AVAILABLE TO GENERAL  
 FURNING. PHOTOGRAPHS OF WEST-LIT, VOR, GZIKOVICH, AND STALY-  
 STOK ARE BEING SENT TO YOU SEPARATELY. THEY SHOULD REACH YOU ON  
 THE FOURTH OF JULY. FROM THEN YOU CAN MAKE YOUR TARGET CHART.  
 CO OPERATIONS WILL BE CONDUCTED MAINLY WITH THE BURANOVICH,  
 SLICE, KALISTOK SLICE AND WEST-LITOVSK SLICE. WE HAVE TWO  
 MORE SLICES FOR LIGHTING. THEY ARE BEING USED BY F-50.  
 LIGHTING ARE BEING TRAINED ON F-50. WE HAVE NO LIGHTING  
 TRAPED AND WOULD THAT A COMPLETE KIT OF SLICES BE SENT US  
 IMMEDIATELY IF NOT SOON. WE WOULD LIKE THE COLLECTION IN OPER-  
 TION FOR PREPARATION AND PLANNING. ~~XXXXXXXXXXXXXXXXXXXX~~  
~~XXXXXXXXXXXXXXXXXXXX~~ AND FOR ANY ADDITIONAL REPAIRS WILL BE  
 SENT. WILL AN OPERATIONAL STATE BE MADE. FOR ANY REPAIRS  
 AND CONSIDERED. WILL THEY BEYOND THE REPAIR.



WHICH FOLLOW HAS BEEN AS THE RESULT OF A CON-  
 TACT WITH GENERAL FURNING, LT. COL. GZIKOVICH, KALISTOK  
 AND STALY-STOK. THE SLICES TO BE TRAINED ON F-50.  
 THE REPAIRS CONSIST OF 3 - 1000 AND 1000 SLICES TO THE LIST.  
 THERE ARE 10 SEARCH LIGHTS. THE SEARCH LIGHTS ARE TO BE  
 TO 10,00 FT. ALL REPAIRS OF THIS AND LIGHTS WILL BE MADE ON  
 THE 3 JULY AND A REPORT AND RECOMMENDATIONS WILL BE MADE BY WHATS.  
 HE FEELS THE REPAIRS AND SLICES ARE NECESSARY. IT IS REQUESTED BY  
 SOVIETS NO. OF SLICES ARE OUTSIDE OF RANGE. 46 OF 120 FLARES DIES.

0713



HEADQUARTERS  
EASTERN COMMAND  
USSTAF  
OUTGOING MESSAGES

General Walsh

|                |          |
|----------------|----------|
| PRECEDENCE     | PRIORITY |
| CLASSIFICATION | SECRET   |

ORIGINATOR

DATE 25 June 1944

P-A-R-A-P-H-R-A-S-E

APPROVED, ADJUTANT.  
KARL A. LANGFORD, Capt., AGD

SRL NR

TO: JMRR (Deane, for answer to WAR's X54979)

JK 840

PRECAUTIONARY MEASURES INCLUDED ADEQUATE SLIT TRENCHES FOR MEN, DISPERSAL OF BOMBS AND GASOLINE DUMPS OUTSIDE FIELD AND MAXIMUM DISPERSION OF AIRCRAFT ON HARD GROUND AVAILABLE. ONLY THREE FIELDS WERE AVAILABLE FOR DEPLOYMENT. BOMBING AND STRAFING ATTACK LASTED ALMOST TWO HOURS AND WAS MADE WITHOUT EFFECTIVE OPPOSITION. FLAK WAS INADEQUATE AND NIGHT FIGHTERS WERE NOT AVAILABLE. EACH DESTROYED AIRPLANE WAS HIT DIRECTLY OR JUST MISSED BY H.E., DEMOLITION BOMB OR STRUCK BY INCENDIARY BOMB. FIELD HAD CRATERS OR UNEXPLODED BOMB EVERY FEW YARDS OVER WHOLE AREA. RUSSIANS STATE THEY DESTROYED 9500 BOMBS ON THIRD DAY AFTER ATTACK. NOT REPORTED WAS NUMBER DESTROYED PRECEDING TWO DAYS. RUSSIANS SUFFERED MANY CASUALTIES AMONG SAPPERS. WE AND RUSSIANS BELIEVE ENEMY USED HE-111's. HE USED A FEW LARGE BOMBS UP TO 1000 LBS. BUT CONCENTRATED ON SMALL FRAGS, ANTI-PERSONNEL AND INCENDIARIES. THE LAST TYPE WERE BOTH THERMITE AND MAGNESIUM. BELIEVE PASSIVE MEASURES WILL NOT PROTECT AIRPLANES AGAINST SUCH ATTACKS. AIRPLANES NOT DESTROYED WERE WELL DAMAGED BY SHRAPNEL. AFTER WITNESSING ATTACK SOVIETS PERMITTED MOVEMENT OF FLYABLE AIRPLANES TO REAR AIRDROMES. THIS PREVENTED SIMILAR DESTRUCTION THE FOLLOWING NIGHT WHEN HUN BOMBED MIRGOROD EFFECTIVELY BUT LESS HEAVILY. HE ALSO ATTEMPTED TO BOMB PIHYATIN BUT DIDNT FIND THE FIELD. HAVE MADE REPRESENTATIONS FOR MORE AIRDROMES TO LOCAL SOVIETS FOR DEPLOYMENT AND FOR OUR OWN NIGHT FIGHTERS AND AA. TASK FORCE SIZE CONSIDERED MINIMUM FOR AERIAL SELF PROTECTION AND MAXIMUM WE COULD CARE FOR

0720Z Sent 25 Jun 44



THE MAKING OF AN EXACT COPY OF THIS MESSAGE IS FORBIDDEN. ONLY SUCH EXTRACTS AS ARE ABSOLUTELY NECESSARY WILL BE MADE AND PROPERLY CLASSIFIED.

0714







0716



0717



0718



|                     |               |
|---------------------|---------------|
| 522.162-1           | DATE TO       |
| 45/04/15 - 45/05/07 | DATE AL 36112 |
| A                   |               |
| M                   |               |

DECLASSIFIED  
TO 100

5-9-93

1029157

Chicago, E-0738, E-0740, B-056.  
with name for files 375 52. Operation Hunt.

0720



~~SECRET~~  
 HQ, US STRATEGIC AIR FORCES IN EUROPE  
**INCOMING MESSAGE**  
 EDITED LITERAL TEXT  
 PRIORITY ~~SECRET~~

RETURN TO  
 MAXWELL AFB, TX, 75702  
 45/04/14  
 45/05/07  
 Saa. 162-1  
 eJ

IN REPLY CITE: M 24207

7 MAY

FROM: USMILMIS MOSCOW 071405B

INTERNAL ADDRESS:

TO : USSTAF 072017B

TO : SPAATZ  
 FROM: DEANE

REF : MX 24203 USSTAF IN 35264

37352

Ref cited msg of 7 May, I wish to point out that on our abandonment of Poltava Soviets intend using it as a training base. For this purpose, it would be desirable from Soviet viewpoint to leave the prefabricated buildings and possibly signal communications.

My recommendation is that we take everything from Poltava that can be moved economically and profitably employed elsewhere. However, I do not recommend shipping materiel from Russia uneconomically for the sole purpose of keeping it out of Russian hands. I believe that we should leave the prefabricated huts but think you should give ESCOM instructions as to disposition of signal equipment, special purpose vehicles, and other critical items.

USSTAF DISTRIBUTION:

- ACTIC : D/OPS (5)
- INFO : D/CG C/S
- D/INT (5)
- D/PLANS (3)
- D/TERS
- ATSCE
- GEN KERR
- C/S
- USSTAF ADV
- T.S. CONTROL

|        |    |     |     |     |     |
|--------|----|-----|-----|-----|-----|
| 8/5/12 | RA | WPA | 0-3 | 0-1 | 0-1 |
|        |    |     |     |     | 0-1 |

USSTAF IN 35288

37352  
 102915

THE MAKING OF AN EXACT COPY OF THIS MESSAGE OR ANY PART THEREOF IS FORBIDDEN IF ADDITIONAL COPIES ARE NECESSARY, THEY WILL BE PARAPHRASED VERSIONS AND WILL BE MARKED WITH THE SECURITY CLASSIFICATION INDICATED HEREON THE COPY WILL BE SAFEGUARDED WITH THE GREATEST OF CARE

~~SECRET~~  
 DECLASSIFICATION CHANGED TO SECRET  
 EDD DIN 5200.9, 27 SEP 58  
 3/10/7  
 G 0138

0721



~~SECRET~~ SECRET

HQ, US STRATEGIC AIR FORCES IN EUROPE  
INCOMING MESSAGE  
EDITED LITERAL TEXT

PRIORITY ~~SECRET~~ SECRET

IN REPLY CITE: IX 24203

7 MAY

ejm

FROM: USMILMIS MOSCOW 071315B

INTERNAL ADDRESS:

TO : USSTAF INFO 071905B  
HQ MTO AF NAPLES INFO  
WAR

TO : MARSHALL  
INFO: SPAATZ, EISENHOWER AND  
MC NERNEY  
SGD : DEANS

REF : W 70140 USSTAF IN 31359 T.S.

37352

1. The Soviet authorities have agreed to proposal for the evacuation of the airbase at Poltava.
2. The Soviet authorities have given us assurances that they will repair our aircraft force landed in Russian controlled territory and evacuate the repaired aircraft and stranded aircrews.
3. Because of recent changes in the situation, the Red General Staff has asked that the details of the evacuation of planes and crews and the detailed arrangements for the evacuation of Poltava be worked out with the Red Air Staff.
4. In view of the above it is requested that General Spaatz be given instructions to direct the evacuation of Poltava and inform ESCOM and USMILMIS of his desires as to disposition of property and installations and the method of evacuation of personnel.

USSTAF DISTRIBUTION:

ACTION: WAR  
INFO : D/OPS (5)  
D/CG OPS  
D/PLANS (3)  
D/PERS  
D/INT (5)  
ATSCE  
GEN INTRR  
C/S  
USSTAF AMW  
T.S. CONTROL

|         |   |   |     |      |   |     |     |         |     |
|---------|---|---|-----|------|---|-----|-----|---------|-----|
| 8/15/45 | 3 | 1 | A-2 | OP-1 | B | C-3 | C-1 | 8/16/45 | C-2 |
|---------|---|---|-----|------|---|-----|-----|---------|-----|

37352  
USSTAF IN 36261  
TS 1319A  
PIC

THE MAKING OF AN EXACT COPY OF THIS MESSAGE, OR ANY PART THEREOF, IS FORBIDDEN IF ADDITIONAL COPIES ARE NECESSARY, THEY WILL BE PARAPHRASED VERSIONS AND WILL BE MARKED WITH THE SECURITY CLASSIFICATION INDICATED HEREON THE COPY WILL BE SAFEGUARDED WITH THE GREATEST OF CARE

CLASSIFICATION CHANGED TO SECRET  
DOD DIR 5200.9, 27 SEP 58

~~SECRET~~ SECRET

TS 1319A  
G 0720

0722

~~SECRET~~

HQ, US STRATEGIC AIR FORCES IN EUROPE

## INCOMING MESSAGE

PRIORITY ~~SECRET~~ TEXTIN REPLY CITE: ~~EX-70140~~ 19 April 1945.

FROM : War 192021z

TO : JSUR

INTERNAL ADDRESS:

TO : OLSON, EISENHOWER, SPAATZ,  
MCNARNEYFROM : Marshall  
Head-9082 has been repeated  
to all addressees.CLASSIFICATION CHANGED TO SECRET  
DDO DIR 5280.9, 27 SEP 58

Joint Chiefs of Staff have approved the following:

A. That the Soviet authorities be informed that because of the advanced stage of the European War we consider it inadvisable to take advantage of their agreement to provide United States Air Bases in the Budapest area.

B. That we abstain from Tactical Air Operations in support of Soviet ground forces except upon specific request from the Soviet authorities.

C. That we request the Soviet authorities to repair our stranded aircraft and evacuate them and our stranded air crews to a central point in the Balkans where they will be turned over to us for on shipment to Italy; and that if this is agreed, we inform the Soviet authorities that we shall no longer require the Air Base at Poltava and, at the same time, express our gratitude for the hospitality they have extended to us in connection with the Frontic bases.

D. That we abandon all efforts to introduce United States personnel into the USSR or USSR - Controlled Territory except on matters essential to the United States in the prosecution of the present war; and that all projects involving American missions to Russia be cleared by an Agency of the Joint Chiefs of Staff. Exception to the foregoing will be made for such projects as the Naval survey party for the Odyssea area, and the United States bombing survey teams."

Paragraph B above is not intended to change the limited zone agreement.

USCJAF MAIN DISTRIBUTION:

ACTION : ~~4/19/45~~ *2/1/45*  
INFO : PLANS (3), D/PLANS, GEN ENBERG,  
~~OPS~~ D/OPS, D/INT (5),  
USCJAF ADV, T.S. CONTROL, ATROC

THE MAKING OF AN EXACT COPY OF THIS MESSAGE OR ANY PART THEREOF IS NECESSARY, THEY WILL BE PREPARED SEPARATELY AND WILL BE MARKED WITH THE SECURITY CLASSIFICATION INDICATED HEREIN. THE COPY WILL BE SAFEGUARDED WITH THE GREATEST OF CARE.

~~SECRET~~

6-0360

0723



0724



0 7 2 5



0726





0 7 2 7

RETURN TO  
The Albert F. Simpson  
Historical Research Center  
Maxwell AFB, AL 36112

522. 16A-2  
45/03/04 - 49/03/07

DECLASSIFIED  
EO 13526

Messages, 772A, 771A, 753E, withdrawn  
from Files Operation Records for 1/  
# N. 11902 - see 24#

5-947

1029158

0728



~~SECRET~~  
 HQ US STRATEGIC AIR FORCES IN EUROPE  
 INCOMING MESSAGE  
 PRIORITY  
 EDITED LITERAL TEXT

IN REPLY CITE: CS 696 IE

7 MARCH

FROM: HQ MAAP 071648A  
 VIA USSTAF HEADLINE 071850A

INTERNAL ADDRESS:

TO : SPAATZ PERSONAL NO 124  
 FROM: BAKER

TO : USSTAF MAIN 071920A

FOR : GEN ANDERSON  
 (BY REQUEST OF COL ALLEN)

REF : MX 47819 NOT IDENTIFIED  
 MX 23074 USSTAF IN 21527 T.S.

Attention is invited to message received from Hill, which apparently was not relayed to you, as follows:

"Reference your MX 47819 and my MX 23074.

Arrangements have been made with Marshal Khudyakov for Reconnaissance on Shuttle Bases mentioned in above referred to cable starting on 10 March subject to securing of approval from the Foreign Office for the entry of US Representatives into Soviet controlled territory, which matter Mr. Harriman will take up with Mr. Molotov tomorrow.

I will submit Halls and your name unless I receive, prior to 0600Z additional names from you. As Marshal Khudyakov told me steel matting would be required on all airdromes in question, it would appear that an Engineer could be profitably included. Recommended, however, that size of party be kept to minimum. Our place of meeting could be Debrecen, Hungary, with exact details if meeting in the city arranged as suggested by you. The incident which you mentioned in your MX 47819 does not affect the desirability of your participating in the Reconnaissance or in negotiations with Russians in any way. General Kovalev will accompany me from Poltava to Debrecen"

I have told Hill that I am prepared to meet him with Hill and the Engineer as soon as he obtains clearance.

I do not believe the Russian insistence on command of airdromes should be allowed to interfere with the project. This worked out all right at Poltava. I have told Hill, however, that we must command all our tactical units and their operations as well as all maintenance and ground personnel which we furnish, including their activities. Unless you direct otherwise, I shall proceed on this basis and not allow the question of airdrome command to scuttle the project.

## USSTAF DISTRIBUTION:

ACTION: D/OPS (5)

D/OPS, D/C-OPS, D/INT (5), D/PERM, D/IMP GEN K. J. BAC, USSTAF ADV C/S T.S. CONTROL

CLASSIFICATION CHANGED TO SECRET  
 DOD DIR 5800.9, 27 SEP 58  
 G. H. BAKER  
 DATE

USSTAF IN 21699

~~SECRET~~

0729

522.162-2  
 45/03/01 - 45/03/07

1029158

TS777A

9311

~~SECRET~~  
 HQ US STRATEGIC AIR FORCES IN EUROPE  
 INCOMING MESSAGE  
 EDITED LITERAL TEXT

URGENT ROUTINE

~~SECRET~~*on extra copy*

37352

MARCH 6

INTERNAL ADDRESS:

TO : SPAAN PERSONAL

FROM : LAMER

MESSAGE TYPE: CS 454 19

FROM: HQ USAF (O) 34114

FROM: HQ USAF (O) 34114

TO : HQ USAF (O) 34114

For General Anderson from Allen--  
 "Which action lies with you"

The following is a message from Downe, # 42989, which it does not appear to  
 be for you, copied to you.

Comments: Hill and I met with Sedyskov on 26 February when Hill presented  
 proposals regarding Backpost bases. His proposals based on your plan include re-  
 quests for the following:

1. 2 bases not more than 20 miles apart, preferably with at least 1 runway  
 6,000 feet by 150 feet, 50 foot ~~width~~, of heavy bomber hard standings or at  
 least capable of being expanded to that extent.
2. Housing for 1000 personnel at each base.
3. Soviet responsibility for base defense both ground and anti-aircraft with  
 an adequate warning system.
4. Bases to be under complete American command with freedom of movement on  
 the area.
5. 1000 fighter and 600 bomber sorties per month.
6. An initial savings of 25,000 and monthly savings of 8,000 with reduction  
 in initial savings to 10,000 if Russians furnish labor and construction material.
7. Two radio channels, each 3 kilocycles and each with 1 or 2 alternate  
 frequencies together with direction finding, airbase control equipment, etc.
8. Operations to be under American control with Moscow notified.
9. Direct liaison with local Russian Commander regarding corridors, occupa-  
 tion, and operational procedures.

WEST F MAIN IN - 21605 ~~SECRET~~ P10

THE MAKING OF AN EXACT COPY OF THIS MESSAGE OR ANY PART THEREOF IS FORBIDDEN. IF ADDITIONAL COPIES ARE NECESSARY, THEY WILL BE PHRA-  
 SINGLED VERSIONS AND WILL BE MARKED WITH THE SECURITY CLASSIFICATION INDICATED HEREON. THE COPY WILL BE SAFEGUARDED WITH THE  
 GREATEST OF CARE.

CLASSIFICATION CHANGED TO SECRET  
 DOD FORM 5400-10, 27 SEP 58

~~SECRET~~

0730

**SECRET**

HQ US STRATEGIC AIR FORCES IN EUROPE  
**INCOMING MESSAGE**  
 EDITED LITERAL TEXT

REF: USAF-2, 2, March 6, 1945 (Page 2)

10. 5 round trips by Air Transport to Italy daily.
11. 20 visas but Soviets kept informed of arrivals and departures.
12. Sweden to fly to force landed aircraft for personnel rescue and plane salvages.
13. Soviets asked to designate available bases and authorize immediate reconstructions.
14. Soviets asked to designate supply route.

The Major said that the proposals would be studied. He indicated that extension of any existing message would require steel mat of other construction. He said construction material for housing would not be available locally. He said that the proposition of American Command was a new proposal. He promised to give answers by returning regarding available area and immediate reconstructions (not yet received). The Ambassador and I have given this project considerable thought, both from the viewpoint of benefits and from viewpoint of future operations with the Russians. Khudyakov indicated that Soviets are not sympathetic to the project as submitted, and we feel that it has been forced on the military by Stalin as a result of a direct appeal for the facilities. We believe that it should therefore be made to show profit as quickly as possible. To this end, I consider that the best procedure would be to lease 2 existing fields, move into them at once and start SECRET operations with least delay, possibly within 2 weeks after their selection. The initial equipment and supply would be started by Air Transport and operating personnel should be prepared for rugged conditions. Supply by sea and railroad should also be started at once to reduce supply by air as soon as possible. The fields should be developed as quickly as possible so as to make them suitable as bombers' havens and to improve living and operating conditions. We feel that an installation that requires from 3 to 4 months to complete before any operations can be started will appear to the Russians as not worth the cost, but more important, it may convince the Russians that we can only operate when conditions are perfect and thus jeopardize future operations with them in other directions. General Hill has not presented the full proposal according to your plan. I recommend that we be given guidance as to our subsequent negotiations.

I reported to Deane that we felt we should stick by the original last project as approved by you and which we turned over to Harrison and which was carried by Kuter to the Tils Conference. My reasons for that recommendation to Deane are as follows:

USSTAF MAIN IN - 21605

(CONT'D)

THE MAKING OF AN EXACT COPY OF THIS MESSAGE OR ANY PART THEREOF IS FORBIDDEN IF ADDITIONAL COPIES ARE NECESSARY, THEY WILL BE PARAPHRASED VERSIONS AND WILL BE MARKED WITH THE SECURITY CLASSIFICATION INDICATED HEREON. THE COPY WILL BE SAFEGUARDED WITH THE GREATEST OF CARE.

- 2 -  

**SECRET**  
 0 7 3 1

 **SECRET**  
 HQ US STRATEGIC AIR FORCES IN EUROPE  
**INCOMING MESSAGE**  
 EDITED LITERAL TEXT  
 URGENT REFERENCE  **SECRET**

REF: CG 575 AG, March 6, Cont'd (Page 3)

a. The original purpose of the revised Frontic it seems to me must be borne in mind and that is:

1. To stimulate cooperation with the Russians, looking to the future, and convince them of the efficiency and powerful effect of our Air Force methods of operation and principles of employment.
  2. To extend the range and effectiveness of the Fifteenth Air Force.
- If we go now to some new bases, as for example 1 fighter field to be operated on a shoe string, we will accomplish neither purpose.

b. It appears to me that whereas Stalin told the President we could have the bases, the Russians are now busily engaged reverting to their old tactics by saying that it is, in point of fact, not feasible logistically and not safe operationally for us to move into the house or the area with them. Deane's message is very depressing and seems to make it clear that the Russians do not in fact want to cooperate in this project. I think if we now change our bases from what we said in December was our minimum requirements to something else we will surely convince the Russians that we do not know our own minds or that we were lavish in our original logistic estimates. You have told me to handle this project but I would like your concurrence in my present plan and program to stick to the program as we gave it to Herring worked out in careful detail and as representing our minimum requirements to do an efficient job.

USSTAF LHM DISTRIBUTION:

ACTION: D/OPS (5)

INFO : C/S  
 D/CG OPS  
 GHI XREFS  
 T. S. CONTROL  
 USSTAF ADV  
 ATSCC  
 D/P.H. PLANNING (3)

USSTAF MAIL IN - 21605

THE MAKING OF AN EXACT COPY OF THIS MESSAGE OR ANY PART THEREOF IS FORBIDDEN IF ADDITIONAL COPIES ARE NECESSARY THEY WILL BE PHRASED VERSIONS AND WILL BE MARKED WITH THE SECURITY CLASSIFICATION INDICATED HEREON THE COPY WILL BE SAFEGUARDED WITH THE GREATEST OF CARE

 **SECRET**

0 7 3 2

**SECRET**  
 HQ US STRATEGIC AIR FORCES IN EUROPE  
 INCOMING MESSAGE  
 EDITED LITERAL TEXT

PRIORITY

~~SECRET~~

In reply cite: MX 23074 MARCH 6

FROM: USSTAF MOSCOW

INTERNAL ADDRESS:

TO : USSTAF  
 C. MERTZ  
 WABTO: ARNOLD, EAKER, AND SPATZ  
 FROM: HILL  
 SGT: DEANE

In meeting with Marshal Okudiyakov this date authorization was granted, pending securing of approval from the Foreign Office for the entry into Soviet-controlled territory of US members of the reconnaissance party, to start the reconnaissance on 10 March of the following airdromes: Ordiada-Mare, Bekechchaba, and Sokodor.

The latter 2 places are located 75 kilometers southwest of Ordiada-Mare.

- 2 A separate cable is being sent General Eaker regarding details of the reconnaissance.
- 3 Marshal Okudiyakov stated that the Red General Staff had decided on a mixed command, as at Poltava, and would not authorize the bases to be completely under US control.

General Kovalev, who is now in command at Poltava, has been designated as the Soviet commander

## USSTAF DISTRIBUTION:

ACTION: D/PEP (3)

INFO: D/CG OPS  
 D/INTEL (5)  
 D/PERS  
 D/SGENERAL KNERR  
 USSTAF ADV  
 AC RECORDS  
 D/OPS (5)  
 USBS

USSTAF IN 21527

THE MAKING OF AN EXACT COPY OF THIS MESSAGE OR ANY PART THEREOF IS FORBIDDEN IF ADDITIONAL COPIES ARE UNNECESSARILY THEY WILL BE PARAPHRASED VERSIONS AND WILL BE MARKED WITH THE SECURITY CLASSIFICATION INDICATED HEREON (EXCEPT WHERE SHOWN OTHERWISE) AND WILL BE MARKED WITH THE GREATEST OF CARE

~~SECRET~~

0733



0 7 3 4





0735





0736



0 7 3 7

DECLASSIFIED  
EO 11652

|                                  |                           |
|----------------------------------|---------------------------|
| 522.162-3<br>45/04/03 - 45/04/04 | RETURN TO<br>AFB AL 86112 |
|----------------------------------|---------------------------|

*Revised, withdrawn from operation - further  
info in 211511 - in file*

1029159

5-993

0738

DECLASSIFIED  
 HQ, US STRATEGIC AIR FORCES IN EUROPE  
**INCOMING MESSAGE**  
 EDITED LITERAL TEXT

PRIORITY

|       |                     |
|-------|---------------------|
| AFSIR |                     |
| MAVW  |                     |
| TO    |                     |
| FROM  |                     |
| DATE  | 45/04/03 - 45/04/04 |
| TIME  | 522.162-3           |

April 4th

In reply cite: WAR 63339

From : WAR

Internal Address:  
 Repeated to all addressees  
 To Deane for Hill  
 Info Spatz and Cannon  
 From Arnold

To : Hq USSTAF  
 Hq MAAF Caserta  
 Hq AF Naples Adv

Ref. : M-23625 is USSTAF Main in 27651

Do not make any further attempt to press for new Frantic bases, reference your MX 23625 dated 3 April 1945. This project is included amongst others now under study and must not be handled as a separate matter. Do not advise Soviets officially of abandonment of this project.

USSTAF DISTRIBUTION:

Action : Deane

Info : D/Ops (5)  
 D/CG Ops  
 D/Intel (5)  
 D/Plans (3)  
 Gen Knerr  
 ATSCB  
 C/S  
 USSTAF Adv  
 T.S. Control

USSTAF Main in 27874



373.54

|         |
|---------|
| 5/4     |
| 3       |
| 1/4-0   |
| 4-0     |
| 8-0     |
| 4-0     |
| 1029159 |

THE MAKING OF AN EXACT COPY OF THIS MESSAGE OR ANY PART THEREOF IS FORBIDDEN. IF ADDITIONAL COPIES ARE NECESSARY, THEY WILL BE PARAPHRASED VERSIONS AND WILL BE MARKED WITH THE SECURITY CLASSIFICATION INDICATED HEREON. THE COPY WILL BE SAFEGUARDED WITH THE GREATEST OF CARE.

~~SECRET~~

0739







URGENT

~~TOP SECRET~~

D/Ops

BC/FPB/ryl

ALFRED R. MAXWELL

Colonel, Air Corps  
Director of Operations

Approved by DCG/Ops \_\_\_\_\_

30 March 1945

- (1) MAAF (Action)  
(2) US EMBASSY MOSCOW (3) USMILMIS MOSCOW (4) WAR  
(All Info)

UAX 66696

MULTIPLE MESSAGE

REVIEW OF THE CURRENT DESIRABILITY OF CONDUCTING FRANTIC OPERATIONS FROM THE BUDAPEST AREA INDICATES PAREN TO EAKER FROM SPAATZ PAREN THAT OUR REQUIREMENTS FOR THESE BASES ARE CONTINUOUSLY DIMINISHING IN DIRECT PROPORTION TO THE SHRINKING OF THE GERMAN BOUNDARIES THUS DECREASING THE OPERATIONAL DESIRABILITY OF THE BASES PD IT NOW APPEARS THAT NO EFFICIENT EMPLOYMENT OF THE BUDAPEST BASES CAN BE REALIZED CMA SINCE FIGHTER ESCORT AND THE STRAFING CMA BOMBING AND HARASSING OF TRANSPORT AND OTHER PROFITABLE TARGETS IN CENTRAL AND SOUTHERN GERMANY CAN BE ACCOMPLISHED FROM ITALIAN BASES PD THE SUPPORT OF ALLIED OFFENSIVES CMA IT IS BELIEVED CMA CAN ALSO BE ACCOMPLISHED EQUALLY AS WELL FROM PRESENT BASES IN ITALY PD BASED ON THE INCREASED TEMPO OF PRESENT GROUND OPERATIONS CMA TIME ELEMENT IS OF MAJOR CONSEQUENCE AND THEREFORE IT IS MANDATORY THAT OPERATIONS BE MAINTAINED AT FULL SCALE AT THIS TIME CMA RATHER THAN THE USE OF THIS VALUABLE TIME IN OVERCOMING LOGISTICAL PROBLEMS ASSOCIATED WITH SUCH A MOVE PD THE OPINION OF YOUR HEADQUARTERS CMA BASED ON DEVELOPMENTS AS OUTLINED IS DESIRED PD IF IN ACCORD WITH OPINIONS OF THIS HEADQUARTERS IMMEDIATE STEPS WILL BE TAKEN TO INFORM THE RUSSIANS THAT THE BUDAPEST AREA BASES NO LONGER CONSTITUTE AN OPERATIONAL REQUIREMENT

378.52  
328.

~~TOP SECRET~~

TS-C 3019

RECORDED  
INDEXED  
MAR 31 1945

0742

TS 1004





0 7 4 3



0 7 4 4



0 7 4 5



0 7 4 6

522.162-4  
44/10/00-45/02/00

RETURN TO  
A-SHRC  
MAXWELL AFB AL 36112

DECLASSIFIED  
1998

5-8-97

Train with Amain Force

1029160

0747

PAGE NO. 2

| NO | TO                                       | FROM             | DATE   |  |
|----|--|------------------|--|--|
| 3  | Col Lee,<br>P&L Sec,<br>D/PH<br>Planning | D/PH<br>Planning | 25 Oct                                       | <p>Request you follow up this matter to determine:</p> <p>(a) If proposed cable attached as inclosure 2 was sent by SHAEF</p> <p>(b) What action Combined Chiefs of Staff took on this cable</p> <p>(c) If direct liaison by SHAEF with Moscow is approved by Combined Chiefs of Staff, what SHAEF personnel are representing that Headquarters.</p> <p style="text-align: right;"><i>Millard Lewis</i><br/>MILLARD LEWIS<br/>Colonel, Air Corps<br/>Deputy Director, Post<br/>Hostilities Planning</p>  |
|    | APSRING<br>MAXWELL AFB AL 36112          | RETURN TO        | 582.102-4<br>44/10/00 - 44/11/00<br>45/02/00 |  |
| 4  | DD/PH                                    | Chief,<br>P&L    | 12 Dec<br>44                                 | <p>In compliance with request in Serial No. 3 above:</p> <p>(a) Proposed cable was sent by SHAEF as 3-64550 SCAP 116, 29 October 1944, General Eisenhower to Combined Chiefs of Staff.</p> <p>(b) Reply of Combined Chiefs of Staff was 41-69563, PACS 111, 28 November 1944, attached to our Top Secret Carrier Sheet to DD/PH, 7 December 1944, subject: "Liaison with Russian Forces."</p> <p>(c) SHAEF Air Staff is scheduled to detail six (6) officers to the proposed SHAEF Liaison Mission. Further discussion of this mission was given in our Carrier Sheet cited in Para. (b) above.</p> <p style="text-align: right;">W. J. LEE, JR.,<br/>Colonel, AG,<br/>Chief, Policy &amp;<br/>Liaison Section</p> <p style="text-align: right;">1029160</p> |
|    |  |                  | 373.52                                       |  |

DO NOT USE; THIS SPACE WILL NOT BE VISIBLE WHEN PAPERS ARE FILED

0748



## CARRIER SHEET

~~SECRET~~

HQ US STRATEGIC AIR FORCES IN

Must remain with attached papers

~~SECRET~~

NUMBER EACH MEMO OR REPLY IN LEFT BORDER DRAW LINE UNDER EACH AND INITIAL IN RIGHT BORDER  
 USE ENTIRE WIDTH OF PAGE

| No. | TO  | FROM  | DATE            | SUBJECT   |
|-----|---|---|-----------------|---|
|     |   |   |                 | Liaison with the Russians<br>Enter File Classification AG 381/016   |
| 1.  | D/PH<br>Planning  | Col.<br>Lee,<br>P&L Sec.,<br>D/PH<br>Planning | 23<br>Oct<br>44 | <p>1. Reference, Top Secret SHAEF letter, GGT 322.01-1/Plans, dated 10 October 1944, Subject: "Liaison with the Russians".</p> <p>2. The subject matter of the SHAEF letter concerns an operational requirement for liaison between SHAEF and USSR.</p> <p>a. The proposed liaison does include provision for coordination of action of tactical air forces and <del>with</del> communications.</p> <p>b. The coordination to be gained through the proposed liaison is essential to efficient operations and there would appear to be no other alternative.</p> <p>3. The subject SHAEF letter is an intra-staff SHAEF publication and the concurrence of this Headquarters is not essential. However, it is recommended that the paper be forwarded to the United States Group Control Council for General Harper's information.</p> <p style="text-align: right;"><i>W. G. Lee, Jr.</i><br/>W. G. LEE, JR.,<br/>Colonel, AC,<br/>Chief, Policy &amp;<br/>Liaison Section</p> |
| 2   | Gen Harper  | D/PH<br>Planning                              | 23 Oct          | <p>1. Attention invited to paragraph 1 above.</p> <p>2. Request return of enclosures when they have served your purpose.</p> <p style="text-align: right;"><i>Millard Lewis</i><br/>MILLARD LEWIS<br/>Colonel, AC<br/>Deputy Director, Post<br/>Hostilities Planning</p>  |
|     | 2 incls:<br>Incl 1--Ltr fr SHAEF, 10 Oct 44, subject "Liaison with the Russians," Top Secret<br>Incl 2--Revised Final Draft (Copy No. 4) SHAEF "Liaison with Russian Forces," Top Secret. PS SHAEF (44) 39. |   |                 | <p>CLASSIFICATION CHANGED TO<br/>DOD DIR 5100.9, 27 SEP 58<br/><i>W. G. Lee, Jr.</i><br/>NAME DATE</p> <p><i>noted RWH</i> ← Gen Harper</p> <p style="text-align: right;"><del>SECRET</del></p>   |

PAGE No.

LIFT HERE. USE OTHER SIDE

TS-90A

0749



SECRET

SUPREME HEADQUARTERS  
ALLIED EXPEDITIONARY FORCE  
G-3 Division (Main)

~~SECRET~~  
Copy No. 4

REF 322.01-1/Plans

10 October, 1944

SUBJECT: Liaison with the RUSSIANS

|      |  |                 |
|------|--|-----------------|
| TO : | Captain L. A. Thackray, AHEF,                  | <u>Copy No.</u> |
|      | Group Captain T.P. Cleave, ARAF,               | 1               |
|      | Lieutenant Colonel J. C. Curtis, G-2 Division, | 2 - 4           |
|      | Colonel W. Whipple, G-4 Division,              | 3               |
|      |  | 6 - 8           |

1. Since the last draft of PS SHAF (44) 39 was prepared it has been learnt that a US/BRITISH/RUSSIAN Advisory Committee is likely to be set up in MOSCOW which includes a member of the RUSSIAN General Staff. This committee, when formed, is likely to be a useful method of liaison with Supreme Headquarters, AEF, in the early stage, before closer liaison on an army group level is required. If we can get liaison on the MOACTY level now, and remove RUSSIAN suspicions, we shall have a chance of getting the lower level liaison later.

2. I have, therefore, redrafted the paper, shortened it, and attached a draft cable to Combined Chiefs of Staff.

3. Will you let us have your concurrence or comments on the new draft as soon as possible?

K. G. McLEAN,  
B35,  
Chief, Plans Section.

Copies to:-

|   |                 |
|---|-----------------|
|   | <u>Copy No.</u> |
| Brigadier K. G. McLean, G-3 Division    | 9               |
| Colonel J. K. Wilson, Jr., G-3 Division | 10              |
| Secretary, Planning Staff               | 11              |
| File                                    | 12              |

~~SECRET~~  
P10

SECRET

0750

HR-STATE (44) 39  
REVISED FINAL DRAFT

~~SECRET~~  
Copy No. \_\_\_\_\_ 4

SUPREME HEADQUARTERS  
ALLIED EXPEDITIONARY FORCE

MEMORANDUM BY PLANNING STAFF  
LIAISON WITH RUSSIAN FORCES

1. As the Russian and Allied forces approach each other in GERMANY considerable liaison will be necessary on such subjects as:-
  - a. Coordination of use of operational wireless frequencies, both ground and air.
  - b. Coordination of action of tactical air forces.
  - c. Coordination of repatriation and care of allied prisoners of war as they become uncovered by operations; and coordination of observation and handling of displaced persons. Reciprocal and mutual privilege for evacuation of P/Ws from camps in the respective zones.
  - d. Coordination of military government policies.
  - e. Coordination of local offensives, exchange of plans and of tactical intelligence.
  - f. With particular reference to 'TALISMAN', coordination of the occupation of BERLIN; and of the control of the boundary between the SHAEF and Russian zones in GERMANY.
2. Present arrangements for liaison by SHAEF with the Russian Armies are slow and cumbersome, consisting as they do of communicating with the Russian General Staff through the Combined Chiefs of Staff and the British and US Missions in MOSCOW.
3. It is understood that the Combined Chiefs of Staff are negotiating with the Russians to set up in MOSCOW a committee consisting of one Russian General Staff Officer, one US Officer and one British Officer to act in an advisory capacity. This may improve liaison but does not shorten the channels from the SHAEF point of view.
4. There are two possible lines to take:-
  - a. To set up direct liaison between Army Groups or SHAEF and the Russian equivalents of our Army Groups. This would be the ideal set up in the later stages when forces are in close contact, or under 'TALISMAN' conditions. However, the Russians are likely to be suspicious of such low level liaison - and are likely to insist on everything being referred to MOSCOW for a decision, causing endless delays. Moreover, many of the subjects in the early stages before close contact are matters which can only be decided in MOSCOW.
  - b. To establish direct liaison between SHAEF and the Russian Army Headquarters in MOSCOW. This would be sufficient during the early stages; would probably be more acceptable to the Russians; would give us a chance to allay their suspicions and pave the way for Army Group level liaison at a later stage.
  5. The simplest way to start this liaison would be to obtain authority for SHAEF to deal direct with the British/US Mission in MOSCOW or with the new committee when set up in MOSCOW, on certain specified subjects, as in paragraph 1 above. If necessary, specialists could be sent out as required to the British/US element of the Committee to assist on particular subjects under discussion.

TS-90A

~~SECRET~~ SECRET

~~EXEMPT FROM AUTOMATIC  
DECLASSIFICATION  
BY THE DATE 08/01/00~~  
PIU

0751

~~SECRET~~

~~SECRET~~

2.

6. Liaison will become essential from the time the Armies are about 300 miles apart, which is determined by the operating range of the tactical support aircraft.

RECOMMENDATION

7. The planning staff therefore recommend that the Combined Chiefs of Staff be asked to arrange direct liaison between SHAPE and MOSCOW. A draft cable is appended (Appendix 'A').

~~SECRET~~

~~SECRET~~

0 7 5 2

~~SECRET~~

APPENDIX 'A'  
To PR SHAFF (44) 34 (Final)

FROM: SHAFF  
TO: COMBINED CHIEFS OF STAFF

1. Under consideration here is method of obtaining closer liaison with RUSSIAN armies as our respective forces approach each other. Subjects on which liaison required includes coordination action of tactical air forces, and of operational wireless frequencies, local problems of prisoners of war and displaced persons, coordination of local offensives and plans, and under 'TALISMAN' conditions local problems of entry into BERLIN and coordination of action along boundary between Supreme Headquarters, AEF, and RUSSIAN zones.

2. As determined by operational range of tactical air forces, closer liaison will become essential when armies approach within some three hundred miles of each other.

3. Understand consultative committee of RUSSIAN, US and BRITISH officers may be set up in MOSCOW. Best method of initiating closer liaison might be for authority to be given to Supreme Commander, AEF, to deal direct with the BRITISH/US Mission in MOSCOW or with this new committee when set up. Specialists could be sent from Supreme Headquarters, AEF, to assist US/BRITISH elements of committee on particular subjects under discussion. At later stage, RUSSIANS might be prepared to accept small liaison missions from Supreme Headquarters, AEF, with RUSSIAN equivalents of Army Groups.

4. If you agree, request authority to initiate direct communications between Supreme Headquarters, AEF, US/BRITISH Mission in MOSCOW and with US/BRITISH elements of the committee in MOSCOW, when formed.

~~SECRET~~  
P/C

0753

## CARRIER SHEET

HQ US STRATEGIC AIR FORCES IN EUROPE

Must remain with attached papers

NUMBER EACH MEMO OR REPLY IN LEFT BORDER. DRAW LINE UNDER EACH AND INITIAL IN RIGHT BORDER.  
USE ENTIRE WIDTH OF PAGE.

| No | TO                            | FROM    | DATE      | SUBJECT  |
|----|-------------------------------|---------|-----------|--|
|    |                               |         |           | Liaison with Russian Forces<br>Enter File Classification AG  |
| 1  | D/ops<br>DC/ops<br>in<br>turn | D/PHF   | 10 Dec 44 | <p>1. For your information.</p> <p>2. Request return of inclosures for file in this Directorate.</p> <p><i>Richard L. ...</i><br/>Colonel, Air Corps<br/>Asst. Deputy Director,<br/>Post-Hostilities Planning</p> <p>3 Incls:<br/>Incl 1 - Carrier sheet sub., "Liaison with Russian Forces, dtd 7 Dec 1944."<br/>Incl 2 - Liaison with Russian Forces, dtd 3 Dec 1944.<br/>Incl 3 - Cable "Liaison with Russian Forces, dtd 28 Nov 1944."</p> |
| 2. | D/PHF                         | DCG/ops | 14 Dec 44 | <p>1. Noted.</p> <p><i>F. L. Anderson</i><br/>F. L. ANDERSON<br/>Major General, U.S.A.<br/>Deputy Commander, Operations</p> <p>3 Incls:<br/>As listed above.</p>   |
|    |                               |         |           |  |

DECLASSIFICATION CHANGED TO SECRET  
EOD DIS 2000-1, 27 SEP 98  
*Thomas* 3/11/97  
NAME DATE

SECRET

73-2 914  
15302

PAGE No. \_\_\_\_\_

LIFT HERE USE OTHER SIDE

0754

**SECRET**  
US STRATEGIC AIR FORCES IN EUROPE

RGL/c

Must remain with attached papers

NUMBER EACH MEMO OR REPLY IN LEFT BORDER    DRAW LINE UNDER EACH AND INITIAL IN RIGHT BORDER  
 USE ENTIRE WIDTH OF PAGE

| No      | TO                    | FROM                  | DATE        | SUBJECT   |
|---------|-----------------------|-----------------------|-------------|---|
|         |                       |                       |             | Liaison with Russian Forces<br>Enter File Classification AG 091/711-2 (Russia)  |
| 1       | D/D MHP<br>Col. Lewis | P & L Sec<br>Col. Lee | 7 Dec<br>44 | <p>REFERENCE:</p> <p>1. a. Top secret SHAFF letter GCT/091.711-2 (Russia) dated 3 Dec 44, subject "Liaison with Russian Forces", copies 2 to 4 inclusive.</p> <p>b. One copy top secret SHAFF incoming message from CCS, WX-69568, 28 November 44, PAGE 112.</p> <p>PROBLEM:</p> <p>2. The problem is as stated in paragraph 1 of SHAFF G-3 draft staff study, dated 3 December 44, for "Liaison with Russian Forces".</p> <p>DISCUSSION:</p> <p>3. A review and study of the SHAFF paper indicated the following comments to be made in so far as USSTAF is concerned:</p> <p>a. Re paragraph 4 a. Liaison for the Strategic Air Forces is not an appropriate consideration on the SHAFF level since it is the responsibility of CG USAF and Marshal of the Air Force. The Strategic Air Forces operate under the CCS in accordance with OUTAGON 29. Therefore, it is inappropriate to include provision for liaison for Strategic Air Operations in the proposed SHAFF Liaison Mission to Russia.</p> <p>b. Re paragraph 4 a. (Pursuant to recommendation made by P/W Section, D/MHP, Col. Robineau) Recommend paragraph be changed to read as follows:</p> <p>"Care and evacuation of allied P/W as they are uncovered by operations" and secure a clarification of the connotation of Allied P/W now that the French are in the field with the U.S. and British.</p> <p>Conference was convened as scheduled with Lt. Col. Baumer, G-3 Ops C, SHAFF, as chairman; USSTAF comments as coordinated with D/D MHP and with D/Ops for D/C Ops (Col. Eaton) as follows:</p> <p>(1) With reference to paragraph 4 a of the Planning paper, it was uniformly accepted that provision for inclusion of liaison for the Strategic Air Forces was inappropriate and this paragraph was deleted from the paper.</p> <p>(2) Re paragraph 4 b, interpolation and amendment made so as to read as follows:</p> |
| PAGE No |                       |                       |             | <p style="text-align: center;"><b>SECRET</b></p> <p style="text-align: right;">373.52</p>   |

0755

~~SECRET~~  
PAGE NO.

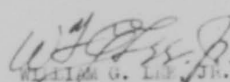
| NO. | TO  | FROM     | DATE     |        |
|-----|---|----------|----------|--------|
| 1   | Col. Lewis  | Col. Lee | 7 Dec 44 | Cont'd |
|     | <p>"Offensives, both major and local, to include exchange of current plans and intelligence on a reciprocal basis".</p> <p>(3) Re paragraph 4 g. It was uniformly agreed that it must be accepted that the French are approaching a position where they will expect, and perhaps warrant, consideration on almost a parity basis with the U.S., British and Soviet. However, at this time such recognition is not to be accorded. The term of reference with respect to P/W will be left as "Allied".</p> <p>(4) Re paragraph 6 g. The size of the missions will be as follows: 6 officers - SHAF Air, 2 officers each from G-1, 3, 5 and Signal Divisions; interpreters - 1 per division.</p> <p>4. The conference was concluded with the understanding that the chairman, Lt. Col. Baumer, G-3 Ops C, would prepare a staff paper recommending a reply from SHAF to CCS.</p> <p>5. As stated in the problem, SHAF is confronted with the necessity of providing for liaison between the field and air forces under its control and those of the USSR as they approach one another. However, as agreed in the conference, it is not appropriate that the establishment of such liaison include provision for the Strategic Air Forces since such liaison is already effected through U.S. Military Mission in Moscow.</p> <p>CONCLUSION:</p> <p>6. No further action is indicated on the part of this Hq in connection with this subject.</p> <p>An effort will be made to secure copy of the outgoing SHAF message to CCS in reply to SACB 112.</p> <p>RECOMMENDATION:</p> <p>7. Recommend that this paper be submitted to D/C Ops for information in connection with future "KANTIC" operations.</p> |          |          |        |
|     | <p style="text-align: right;"> <br/>           WILLIAM G. LEE, JR.<br/>           Colonel, Air Corps         </p>  |          |          |        |

DO NOT [REDACTED] THIS [REDACTED] WILL NOT BE VISIBLE WHEN PAGES ARE FILED

0756



~~SECRET~~~~SECRET~~

COPY NO. 1

SUPREME HEADQUARTERS  
ALLIED EXPEDITIONARY FORCE  
G-3 Division (Main)

SHLEF/17245/18/Ops(C)  
GCT/091.711-2(RUSSIA)

3rd December, 1944

SUBJECT : Liaison with Russian Forces

Copy No:

|         |   |         |
|---------|---|---------|
| TO :    | Captain L. A. Thackrey, MGP                             | 1       |
|         | Colonel G. G. Lee, MGP                                  | 2 - 4   |
| SHLEF:- |   |         |
|         | Group Captain G. F. Glove, Air Staff, (Plans Section),  | 5 - 6   |
|         | Colonel E. P. Straub, G-1 Division, (P&C),              | 7 - 8   |
|         | Lieutenant Colonel J. O. Curtis, G-2 Division, (CI),    | 9       |
|         | Colonel H. L. Twitchell, G-3 Division, (O & L),         | 10      |
|         | Lieutenant Colonel R. G. M. Phillimore, G-3 Division,   | 11      |
|         | (Plans),  |         |
|         | Colonel J. A. Minton, G-3 Division (Ops & Sub-section), | 12      |
|         | Colonel W. Hipple, G-4 Division, (Log Plans),           | 13 - 14 |
|         | Colonel W. H. Moffitt, Jr, G-5 Division, (Displaced     | 15 - 16 |
|         | Personnel),   |         |
|         | Colonel J. L. Ellis, Signal Division, (Plans & Ops)     | 17      |

Attached herewith is a skeleton draft comprising an agenda for discussion of P.03 112 (Reference Number M-69568, dated 28th November, 1944) on Liaison with the Russian Forces, SHLEF/17245/18/Ops(C) GCT/091.711-2 (RUSSIA) dated 3rd December, 1944.

A meeting will be held at 14.30, Tuesday, 5th December, 1944, in the Chief of Staff's Conference Room (Number 24), Hotel Trison, to discuss the above matter.

For the SAC of G-3:

*[Signature]*  
RUSSELL H. JONES,  
Colonel, G-3,  
Executive Officer, G-3.

Copies to:-

|  |         |
|--|---------|
| Secretary General Staff                      | 18      |
| Major A. J. E. Crick, G-2 Division,          | 19      |
| Major General H. R. Bull, G-3 Division,      | 20      |
| Major General J. P. L. Hitley, G-3 Division, | 21      |
| Brigadier H. G. McLean, G-3 Division,        | 22      |
| Brigadier P. de Val, G-3 Division,           | 23      |
| Colonel Earle H. Jones, G-3 Division         | 24      |
| Colonel J. H. Wilson, Jr, G-3 Division,      | 25      |
| Colonel T. H. Grandbrook, G-3 Division,      | 26      |
| Colonel C. R. Rutz, G-3 Division,            | 27      |
| Colonel J. H. Alms, G-3 Division,            | 28      |
| War Diary (3)                                | 29 - 31 |
| File.  | 32      |

~~SECRET~~

SECRET

0757

~~SECRET~~  
 STAFF  
 SUPREME HEADQUARTERS  
 ALLIED EXPEDITIONARY FORCE  
 G-3 Division (Liaison)

STAFF/17245/18/Cas(C)  
OCT/091.711-2(RUSLIA)

~~SECRET~~  
 COPY 12  
 3rd December, 1944

LIAISON WITH RUSSIAN FORCES

I PROBLEMS

1. To study and make recommendations on P.O. 112, a message giving the Combined Chiefs of Staff's views relative to improvement of liaison arrangements with the Russian armies in the field. The Combined Chiefs of Staff's most urgent consideration is to obtain an immediate agreement for Allied Air Liaison between SACRED and Russian armies operating in the vicinity of his command. After the appointment of the latter Allied Air Liaison, the Combined Chiefs of Staff propose to take up the question of exchange of full scale liaison missions between SACRED's and SACRED's Headquarters and the appropriate Russian Commands in the field. Accordingly SACRED has been asked to make recommendations as to the size of the mission, ranks of officers, communications, designation of headquarters, by type, which two would be liaison, and any other pertinent matters.

II DISCUSSION

2. The G-3 Planning Staff of Supreme Headquarters, AEF, wrote a memorandum (IS-CHIEF(44)39(Final)), on the subject of liaison with the Russian forces, in mid October. This paper listed the duties envisaged for the liaison mission, and mentioned two possible lines to take in the establishment of this liaison, viz: between Army Groups or Supreme Headquarters, AEF, and the Russian equivalent of our Army Groups; between Supreme Headquarters, AEF and the Russian Army Headquarters in ROCCO. The conclusions drawn were that the liaison between Supreme Headquarters, AEF and the Russian Army Headquarters in ROCCO was preferable, adding that the liaison would become essential when the armies are about 300 miles apart, which is determined by the operating range of the tactical support aircraft.

3. The question of liaison is complicated because there is believed to be no counter part of Supreme Headquarters, AEF, within the Red Army (G-2 is attempting to check this item). Direct liaison between Supreme Headquarters, AEF, and the Red Army Command in ROCCO, if that is the top Field Command, might in some measure tend to lower the prestige of the United States and British missions to ROCCO.

Liaison on the Army Group level would call for a large Supreme Headquarters, AEF Mission and might therefore be unacceptable to the Russians. The tendency is to pave the way for liaison on the Army Group level, at a later stage, by establishing a limited liaison mission direct to the Red Army Field Command at this time.

If, by some chance, the Red Army Field Command is outside ROCCO, a direct liaison from Supreme Headquarters, AEF, to that body would raise certain questions as to the Supreme Headquarters, AEF Mission's relationship with the United States and British Missions to ROCCO.

4. The duties suggested for a limited Supreme Headquarters, AEF Liaison Mission might include coordination of:-

- a. Strategic air operations between the Eastern front (Northern and Central sectors) and the Supreme Headquarters, AEF, front.
- b. Offensives, both major and local, to include exchange of plans and intelligence. *on a reciprocal basis.*

~~SECRET~~

0 7 5 8

~~SECRET~~SECRET  
2.

- c. Operational radio frequencies, ground and air.
- d. Repatriation and care of allied prisoners of war, as they are uncovered by operations.
- e. Problems raised by displaced persons other than those of Soviet nationality.
- f. Operations of Tactical Air Forces when the Allied and Soviet forces have approached within approximately 300 miles of each other.

5. It is recognized that the Allied Strategic Air Forces will require liaison with the Russian forces. However, the sending of two liaison missions, one for Strategic Air Forces and another for Supreme Headquarters, AEF, might well arouse the suspicions of the Russians. The attachment of a staff for the Strategic Air Forces to the Supreme Headquarters, AEF Liaison Mission would seem advisable.

6. In the resolution of the above factors which influence the type and scope of the Supreme Headquarters, AEF Liaison Mission, certain questions arise:-

- a. With what Russian staff will a Supreme Headquarters, AEF Liaison be established?
- b. Should the Supreme Headquarters, AEF Liaison have its own signal communications?

A signal unit would add immeasurably to the size of the Supreme Headquarters, AEF Liaison Mission. For necessary communications it might be possible for the Supreme Headquarters, AEF Liaison Mission to pass its messages through a limited Russian censorship to the United States and British Missions to Moscow.

- c. What is to be the size of the Mission?

It is felt that the Supreme Headquarters, AEF Liaison Mission might be restricted to twelve members, two each for the Air Staff, G-1, G-2, G-3, G-5 and Signal Division. There will be a large requirement for interpreters and perhaps for some sort of housekeeping detachment. Transportation will be necessary and this will require vehicles and planes with the necessary personnel to operate them.

Since the Heads of United States and British Missions to Moscow report directly to their respective Chiefs of Staff, and since they are Major Generals, it would appear that a Supreme Headquarters, AEF, Liaison Mission will have to be restricted to a ceiling of Brigadier or Brigadier General. Most of the members of the Mission will be Colonels or Lieutenant Colonels.

### III RECOMMENDATIONS

- 7. That Liaison Missions be exchanged between SCAEF and the appropriate Red Army Field Commander.
- 8. That the Mission's duties should include: (approximately those listed in paragraph 4 above).
- 9. That in order to avoid complications with the Russians, the Strategic Air Forces representation be attached to the Supreme Headquarters, AEF Liaison Mission.
- 10. That there be no inherent signal communications in the Liaison Mission.
- 11. That the size of the Supreme Headquarters, AEF, Liaison Mission be limited to officers, and that the head be of the maximum rank of Brigadier General or Brigadier.

~~SECRET~~

SECRET

0759

~~SECRET~~

~~SECRET~~

SHAEF

STAFF MESSAGE CONTROL

INCOMING MESSAGE

~~SECRET~~

THE MAKING OF AN EXACT COPY OF THIS MESSAGE IS FORBIDDEN.

0760

THIS PAGE IS DECLASSIFIED IAW EO 13526



THIS PAGE IS DECLASSIFIED IAW EO 13526

~~SECRET~~

SECRET

~~SECRET~~

SECRET

SHAEF

STAFF MESSAGE CONTROL

INCOMING MESSAGE

~~SECRET~~

~~SECRET~~

SECRET

COPY NO.

THE MAKING OF AN EXACT COPY OF THIS MESSAGE IS FORBIDDEN

0762



**SECRET**

HQ US STRATEGIC AIR FORCES IN EUROPE

HR

## INCOMING MESSAGE

EDITED LITERAL TEXT

PRIORITY ~~SECRET~~

IN REPLY CITE: MX-22807, FEB 21. INTERNAL ADDRESS:  
 FROM: USMILMIS 2201100Z TO: ARNOLD  
 TO : WAR INFO: SPAATZ  
 BAKER  
 FROM: HILL  
 INFO: HQ USSTAF 211004A SGD: DEANE  
 NAPLES

{ WAR 39958 is USSTAF IN 18589  
 REF: 45929 - USSTAF IN 17073

WARX-39958 is subject. Upon my return from Crimea request was made for conference on subject of 45929 with General Nikitin, Assistant Commander, Red Army Air Force. Two days later they informed me that he was out of town and would be back 20 February.

On 16 February a request was made for appointment with Marshal of Aviation S A Khudyakov. As no definite answer was received, a letter was sent to Marshal Khudyakov on 17 February requesting a meeting. On 19 February information was received that Marshal Khudyakov would meet me on 20 February. Am at present awaiting information from him regarding time of the appointment.

Will inform you of the results of the conference, at which I will attempt to secure from him a designation of available airdromes and arrange for reconnaissance by a representative of MAAP or Fifteenth Air Force to be designated by General Baker, the Base Commander to be who will be designated by General Baker, possibly General Baker himself, and me. Also to be discussed will be the logistical aspects of the project.

The failure of the Soviets to arrange a meeting indicates to me simply that they were not prepared to discuss the subject until studied by their Staff.

USSTAF MAIN IN 18785

(cont'd)

- 1 -

DYPH Planning  
 Master File Copy 373,52

THE MAKING OF AN EXACT COPY OF THIS MESSAGE OR ANY PART THEREOF IS FORBIDDEN IF ADDITIONAL COPIES ARE NECESSARY, THEY WILL BE PARAPHRASED VERSIONS AND WILL BE MARKED WITH THE SECURITY CLASSIFICATION INDICATED HEREON THE COPY WILL BE SAFEGUARDED WITH THE GREATEST OF CARE

CLASSIFICATION CHANGED TO SECRET

DOD DIR 5209.9, 27 SEP 58

**SECRET**

NAME DATE  
 3/1/58 TS652  
 9036

0763



REF: MX-22807, FEB 21, CONT'D. (PAGE 2).

USSTAF MAIN DISTRIBUTION:

ACTION: (WAR)

INFO : D/OPS (5)  
D/CGOPS  
~~C/P.H. PLANNING (3)~~  
GEN KERR  
ATSCE  
USSTAF ADV  
C/S  
T.S. CONTROL

USSTAF MAIN IN 19785

0 7 6 4

██████████  
 HQ US STRATEGIC AIR FORCES IN EUROPE

INCOMING MESSAGE

EDITED LITERAL TEXT

PRIORITY ██████████

IN REPLY CITY: N 39958

20 FEB

FROM: WAR 192203A

INTERNAL ADDRESS:

TO : USSAF 2000535A

TO : DEANE  
 INFO: SPAARZ, BAKER  
 FROM: ABEOLD

CASERTA  
 NAPLES ADV AF

REF : N 45929 USSTAF IN 17073

Subject: MX 45929 of 12 Feb.

Desired is present status of your negotiations with the Soviets on this subject.

USSTAF DISTRIBUTION:

ACTION: DEANE

INFO : D/OPS (5)  
 D/C OPS  
 ATSCB  
 GEN KERR  
 C/S  
 REDLINE  
 P.S. CONTROL  
 D/PH Planning (3)

REGRADED  
 ORDER SET BY  
 DTIC/STP 10

|     |
|-----|
| 2/2 |
| 3   |
| -   |
| 0/A |
| B   |
| C   |

373.54 USSTAF IN 18589

THE MAKING OF AN EXACT COPY OF THIS MESSAGE OR ANY PART THEREOF IS FORBIDDEN IF ADDITIONAL COPIES ARE NECESSARY THEY WILL BE PARAPHRASED VERSIONS AND WILL BE MARKED WITH THE SECURITY CLASSIFICATION INDICATED HEREON THE COPY WILL BE SAFEGUARDED WITH THE GREATEST OF CARE

██████████

0765

~~SECRET~~ SECRET

HQ US STRATEGIC AIR FORCES IN EUROPE  
INCOMING MESSAGE  
EDITED LITERAL TEXT

URGENT ~~SECRET~~ SECRET

IN REPLY CITE: MX-46929, FEB 12. INTERNAL ADDRESS:  
TO: DEANE MOSCOW RMT  
FROM: CASERTA 121010A INFO: AGWAR  
FOR: ARNOLD  
TO : USSTAF 121200A GILES  
WAR TO: SPAATZ USSTAF MAIN  
BAKER MAAP  
FROM: KUTER  
SGD: BAKER

Agreement has been reached at highest level for 2 air bases in Vienna-Budapest area to be made available for Allied Air Forces.

Request you arrange details with Soviets as soon as possible.

USSTAF MAIN DISTRIBUTION:

ACTION: (MOSCOW)

INFO : D/OPS (5)  
D/CG OPS  
ASC  
GEN KNERR  
C/S  
T.S. CONTROL  
D/PHPlanning (3)

USSTAF MAIN IN 17073

D/PH Planning  
Master File Copy 373.52

~~SECRET~~  
BY *[Signature]* /fio

CLASSIFICATION CHANGED TO SECRET  
DOD OR 27 SEP 58  
DATE

THE MAKING OF AN EXACT COPY OF THIS MESSAGE OR ANY PART THEREOF IS FORBIDDEN IF ADDITIONAL COPIES ARE NECESSARY, THEY WILL BE PARAPHRASED VERSIONS AND WILL BE MARKED WITH THE SECURITY CLASSIFICATION INDICATED HEREON THE COPY WILL BE SAFEGUARDED WITH THE GREATEST OF CARE.

~~SECRET~~ SECRET

0766

PRIORITY

TOP SECRET

SECRET

CHARLES W. TAYLOR  
Colonel, Air Corps  
Executive

Approved for Deputy Commander, Operations \_\_\_\_\_

17 February 1945

LIA 64406

FORM

KNOWING TO THE WELL AS I AM SURE THAT YOU ARE FURNISHING ARRANGEMENTS FOR THE DISPATCH  
BASED HEREON WITH YOU TO ADVISE THAT NIGHT DATED SIXTEEN FEBRUARY PLAIN TO LEAVE  
SEVEN SEVEN SEVEN I FEEL IT NECESSARY THAT THE COMMANDER OF THESE BASES BE AN  
OFFICER FROM THE UNITED STATES AIR FORCE WITH OPERATIONAL EXPERIENCE IN ORDER TO MAINTAIN  
CONTACT THROUGHOUT THE PERIOD AS AVAILABLE TO I HAVE DELEGATED TO GENERAL TAYLOR THE  
ADMINISTRATION OF THE OPERATIONS FOR THESE BASES AND HE WILL KEEP YOU  
ADVISED AS I HAVE ASKED HIM TO ADVISE YOU THROUGH THE CHANNELS AND WILL BE CONSIDERED  
OF THE SUBJECT AND MAKE ARRANGEMENTS FOR HIS DISPATCH TO YOU AS SOON AS  
ARRANGEMENTS ARE MADE FROM YOU

37352

DMT

37352

4308

0767

~~SECRET~~ SECRET

HQ US STRATEGIC AIR FORCES IN EUROPE  
 INCOMING MESSAGE PMC  
 EDITED LITERAL TEXT

D/P H Planning  
 Master File Copy

PRIORITY ~~SECRET~~ SECRET

In reply cite: M 22738

16 Feb. 1945

From: USMILMIS 160930Z

Internal address:

To : Hq USSTAF 161712A

To: Spantz (For his eyes  
 only)

From: Hill  
 Sgd: Deane

A conference has been requested with representatives of Red Air Staff reference shuttle bases in Budapest Area. They will be requested to furnish names of available airdromes.

The next step will be to make a reconnaissance of the airdrome sites, to determine suitability, and requirements. I recommend that reconnaissance party consist of, a representative of MAAF, the person to be designated as Commanding Officer of the project, and myself, together with such Russian representatives as they desire. Details of proposed reconnaissance will be furnished you as soon as plans can be made.

I consider that the success of this project will, to a large extent, depend upon the ability of the Officer selected as Commander. He must have tact, energy, knowledge, high standards, and patience. Colonel W. G. Lee, Jr, now with Post Hostilities Planning Section, USSTAF, has these characteristics. Furthermore he has worked with me for 2 years to my complete satisfaction. His designation would insure complete understanding between the Base Commander and this Headquarters. It is, therefore, recommended that you designate Lee for this assignment in order that he may be prepared to join reconnaissance party on short notice and return to Moscow with me upon completion of reconnaissance to assist here in the development of the project and in order that he may secure all possible background.

Provided you concur in Lee's assignment to this project, it is recommended that he be directed to make application for visa to enter Russia. This mission should be notified of date and place of application for visa, giving age, place, and date of birth.

USSTAF MAIN DISTRIBUTION:

Action: Gen. Anderson

Info: 3/6 COPY OF THIS MESSAGE OR ANY PART THEREOF IS FORBIDDEN IF ADDITIONAL COPIES ARE NECESSARY, THEY WILL BE FURNISHED SEPARATELY. THIS MESSAGE WILL BE MARKED WITH THE SECURITY CLASSIFICATION INDICATED HEREON THE COPY WILL BE CLASSIFIED UNLESS OTHERWISE INDICATED BY THE OFFICE OF ORIGIN.

D/P. H. Planning (3) USSTAF MAIN-IN 1806

~~SECRET~~ SECRET

0768



~~TOP SECRET~~ -SECRET  
 HQ US STRATEGIC AIR FORCES IN EUROPE  
 INCOMING MESSAGE  
 EDITED LITERAL TEXT

PRIORITY ~~TOP SECRET~~

IN REPLY CITE: N 46460                      FEB 17                      INTERNAL ADDRESS:  
 FROM: HQ MAAP                              170935A                      FOR : ANDERSON  
 TO : USSTAF MAIN                          171252A                      FROM: BAKER

I have a message from Hill, Moscow, indicating he desires to pick a Commander for the Frantic Bases and also indicating some changes in plan.

I understand General Spaatz is absent and that I will not see him until Monday. I am most hopeful you will make no commitments on Hill's proposals until I have an opportunity to discuss the subject with General Spaatz. I am unalterably opposed to picking any Commander for Frantic Bases who has not had operational experience. I would much prefer for the Commander to come from the Fifteenth Air Force. The liaison and close working relations between the tactical units and Base Commanders is too essential to take any chances in this regard. I also believe it is an error to start to change the plan we worked out in great detail with you with considerable care. If Hill is allowed to alter it willy nilly we will never know where we stand.

USSTAF MAIN DISTRIBUTION:

ACTION: GEN ANDERSON  
 INFO : C/S  
           T. S. CONTROL  
           D/P. H. Planning (3)

USSTAF MAIN IN -- 18106

NO MAKING OF AN EXACT COPY OF THIS MESSAGE OR ANY PART THEREOF IS FORBIDDEN IF ADDITIONAL COPIES ARE NECESSARY, THEY WILL BE MADE UNLESS OTHERWISE INDICATED AND WILL BE MARKED WITH THE SECURITY CLASSIFICATION INDICATED HEREON THE COPY WILL BE SAFEGUARDED WITH THE HIGHEST OF CARE  
 CLASSIFICATION CHANGED TO  
 DOD DIR 5200.9, 27 SEP 58

~~TOP SECRET~~ SECRET

0 7 7 0



~~SECRET~~ SECRET

1 February 1945

MEMORANDUM FOR: Colonel W. G. Lee,  
Hqs., USSTAF.

SUBJECT : U.S. Policy Military Operations - Norway.

The following represents the latest U.S. policy regarding Allied military operations in Norway available in this office. It is contained in CCS 626/2, dated 31 August 1944, which has the approval of the Combined Chiefs of Staff:

- (1) Approved message to General Deane, USMILMIS, Moscow (also sent to General Burrows, British MILMIS, Moscow) -- see enclosure 1.
- (2) Approved message to Generals Deane and Burrows for background information -- see Enclosure 2.
- (3) Approved message to SCAEF notifying him of this action -- see Enclosure 3.
- (4) U.S. and U.K. have concluded a Civil Affairs Agreement with Norway -- see CCS 274/5.

CARL J. MARTIN,  
Lt. Col., A. C.

3 Enclosures

~~SECRET~~  
PIC

873-52

CLASSIFICATION CHANGED TO SECRET  
EEO 12812-101, 21 SEP 58

NAME DATE

~~SECRET~~ SECRET

75603  
4905

0771

~~SECRET~~ SECRET

ENCLOSURE 1

Message to U.S. and British Mil. Missions in Moscow from CCS,  
dated 30 August 1944.

1. Combined Chiefs of Staff consider it advisable to open early military conversations with Soviet General Staff through you.
2. You should bear in mind that our object is to re-establish the legal Norwegian Government in full control as early as possible after the German withdrawal.
3. Plans for occupying Norway under RANKIN "B" and "C" conditions are as follows:
  - (1) RANKIN "B" (Organized German withdrawal from Norway)  
To occupy in initial stages any two of following:
    - (a) FINMARK (Hammerfest and Kirkenes).
    - (b) Tromsø or Narvik.
    - (c) Trondheim.Subsequently Stavanger and Bergen, Christiansund (s) and Oslo would be occupied as forces became available.
  - (2) RANKIN "C" (German unconditional surrender and cessation of organized resistance in northwest Europe).  
To occupy first southern Norway and then send, if required, a force with a Norwegian detachment to eastern FINMARK. Norwegians, however, are anxious for FINMARK to be reoccupied as soon as possible. It might therefore be desirable to send to FINMARK area Norwegian warships with some Norwegian troops immediately after RANKIN "C" conditions arise. SCAEF is being instructed to consider the possibility of this.
4. It should be made clear to Soviets that since above plans for RANKIN "B" depend on the method of German withdrawal they are provisional. Soviets should be informed that we appreciate that they may already have plans for following up a German withdrawal through FINMARK. You should therefore invite Soviets to concert their plans with ours using the following points as basis:
  - (a) Necessity for harassing enemy during his withdrawal;
  - (b) Advantages of stimulating Norwegian resistance by sending in Norwegian forces as early as possible;
  - (c) Desirability of establishing a naval base in northern Norway for escorts protecting convoys to Russia.
5. You should ask the Soviets if they have any objection to participation by Norwegian Military Attache in your conversations.

710

~~SECRET~~ SECRET

73603  
8905

0 7 7 2

~~SECRET~~

ENCLOSURE 2

Second Message to U.S. and British Mil. Missions in Moscow  
from CCS, dated 30 August 1944.

In connection with our immediately preceding signal, following is background for your personal information only.

1. No repeat no agreement exists with the Russians acknowledging that Norway is a British/American sphere of operations. Although it is to our advantage for the Russians to harass a German withdrawal as we have insufficient forces to do this ourselves our long term requirement is to ensure that they should not repeat not permanently occupy Norwegian territory in view of potential threat to North Atlantic trade routes, Iceland and the northern approaches to the North Sea. Our purpose must be therefore to avoid any clash with the Russians in Norway and yet to safeguard our long term interests.

2. Combined Chiefs of Staff have no evidence that the Russians intend to establish themselves in FINMARK but it is felt that it would be desirable to arrange as far as possible for a joint occupation by Russian, Norwegian and British forces rather than by a purely Russian force. Nevertheless, if the Russians enter Norway during the course of operations against the Germans it is considered undesirable for us to intervene since a Russian/Norwegian civil affairs agreement has been concluded which covers this contingency.

~~SECRET~~

75603  
9/45

0 7 7 3

~~SECRET~~

ENCLOSURE 3

Message to SCAEF from GCS, dated 30 August 1944.

1. Combined Chiefs of Staff have instructed U.S. and British Military Missions to Moscow to initiate conversations with Soviet General Staff and to invite Soviets to concert Russian plans for following up German withdrawal through Norway with your plans for occupying Norway under RANKIN conditions.
2. In view of Norwegian anxiety that FINMARK should be reoccupied as early as possible you should consider despatch of a Norwegian warship with token force of Norwegian troops, if available, to FINMARK as early as possible under RANKIN "C" conditions if situation permits.
3. In absence of prior agreement with Soviets no repeat no forces other than Norwegian should be sent to any area of Norway entered by Soviets in course of their operations against Germans.
4. You should now inform Norwegian Military Authorities of your plans for taking advantage of RANKIN "B" conditions in Norway.

~~SECRET~~

TJ 603  
8705

0774



0775



0 7 7 6









0 7 7 8

DECLASSIFIED  
EO 11652

RETURN TO  
The Albert F. Simpson  
Historical Research Center  
Maxwell AFB, AL 36112

522.142.5  
44/05/03-44/11/19

5407

1029161

5/11/19

0779



~~SECRET~~ -SECRET  
HQ US STRATEGIC AIR FORCES IN EUROPE  
INCOMING MESSAGE  
EDITED LITERAL TEXT

*5/17/46*

THE MARKING OF THIS DOCUMENT OR ANY PART THEREOF IS FORNOFFICIAL USE. IF ADDITIONAL COPIES ARE NECESSARY, THEY WILL BE REPRODUCED AND MARKED WITH THE SECURITY CLASSIFICATION INDICATED HEREIN. THE COPY WILL BE REPRODUCED WITH THE SAME SECURITY CLASSIFICATION.  
SECURITY CLASSIFICATION: SECRET  
YOU DO NOT HAVE TO MARK IT

*SECRET*

*757-6*  
*6781*

NAME

DATE

~~SECRET~~  
0781

~~SECRET~~ SECRET  
HQ US STRATEGIC AIR FORCES IN EUROPE  
INCOMING MESSAGE  
EDITED LITERAL TEXT

51352

17/11 1645  
3

|    |
|----|
| 1  |
| 2  |
| 3  |
| 4  |
| 5  |
| 6  |
| 7  |
| 8  |
| 9  |
| 10 |
| 11 |
| 12 |
| 13 |
| 14 |
| 15 |
| 16 |
| 17 |
| 18 |
| 19 |
| 20 |

~~P10~~

51352

THE INFORMATION CONTAINED HEREIN IS UNCLASSIFIED EXCEPT WHERE SHOWN OTHERWISE. WHERE NECESSARY, ADDITIONAL COPIES AND NECESSARY THEY WILL BE PERMANENTLY CLASSIFIED AND GRADUATED WITH THE SECURITY CLASSIFICATION INDICATED HEREON THE COPY WILL BE SAFEGUARDED WITH THE GREATEST CARE.  
DOD DIR 2200.9, 27 SEP 58

~~SECRET~~ SECRET

T5217 6695

0782

~~SECRET~~  
HQ US STRATEGIC AIR FORCES IN EUROPE  
INCOMING MESSAGE  
EDITED LITERAL TEXT

CLASSIFICATION CHANGED TO UNCLASSIFIED  
DOD DIR 5100.9, 27 SEP 98  
NAME \_\_\_\_\_ DATE \_\_\_\_\_

THE MAKING OF AN EXACT COPY OF THIS MESSAGE OR ANY PART THEREOF IS FORBIDDEN IF ADDITIONAL COPIES ARE NECESSARY THEY WILL BE PARAPHRASED VERSIONS AND WILL BE MARKED WITH THE SECURITY CLASSIFICATION INDICATED HEREON THE COPY WILL BE SAFEGUARDED WITH THE GREATEST OF CARE

~~SECRET~~

0783

~~TOP SECRET~~ SECRET  
HQ US STRATEGIC AIR FORCES IN EUROPE  
INCOMING MESSAGE  
EDITED LITERAL TEXT

3242

~~TOP SECRET~~ SECRET PRIORITY

In reply refer to: 3242  
25 Oct 1954  
To: SAC, COMUSMACV  
From: SAC, USAF, AFSA  
This is 3242 111

3242

1. Letterhead reference case is matter of establishing inter-United States Liaison Office on the respective bases approach with close cooperation in which Liaison will be required to take coordination of action of tactical air forces and of operations of tactical air forces. Level of coordination of operations of the air is required in level of coordination and close and active liaison conditions like the plans of major 1954 3242 and coordination of action along Liaison between approach headquarters of the respective forces and tactical bases.

2. It is intended to use Liaison Office of tactical air forces which Liaison will be required to take coordination of action of tactical air forces and of operations of tactical air forces.

3. Liaison Office will be established as Liaison Office of tactical air forces and Liaison Office will be required to take coordination of action of tactical air forces and of operations of tactical air forces.

THE MAKING OF AN EXACT COPY OF THIS MESSAGE OR ANY PART THEREOF IS FORBIDDEN IF ADDITIONAL COPIES ARE NECESSARY, THEY WILL BE MADE BY THE MESSAGE REVISION AND TRANSMISSION SECURITY CLASSIFICATION INDICATED HEREON. THE COPY WILL BE SAFEGUARDED WITH THE GREATEST CARE. (STAMP) 270

NAME: [Signature] DATE: [Signature]

~~TOP SECRET~~ SECRET

15169a 6490

0784



~~SECRET~~ SECRET

HEADQUARTERS  
UNITED STATES STRATEGIC AIR FORCES IN EUROPE  
Office of Director of Post Hostilities Planning

3735 ✓  
APO 623, U.S. Army  
17 October 1944

SUBJECT: Liaison with Russian Forces.  
TO: Deputy Commander, Operations.

1. Attached is copy of final draft, dated 17 October 1944, of SHAFF Planning Staff memorandum, subject: Liaison with Russian Forces.

2. This memorandum proposes that the Supreme Commander request authority from the Combined Chiefs of Staff to initiate direct communications between SHAFF and the "U.S./British Mission" in Moscow and the "U.S./British elements" of the tripartite military advisory committee which the Combined Chiefs have proposed be set up in Moscow.

3. The main reason given in this paper for establishing this SHAFF liaison with the Soviets is the need for coordination of action of U.S., British and Soviet tactical air forces.

4. The paper states that the "ideal set-up" would be direct liaison on the Army Group/Tactical Air Force level, but rejects this solution on the ground that "the Russians are likely to be suspicious of such low-level liaison".

5. If General Eisenhower consults General Spaatz before authorizing dispatch of the proposed cable to the Combined Chiefs, it is recommended that General Spaatz point out that:

(a) The Russians are likely to be even more suspicious of liaison with SHAFF, as a combined U.S./British headquarters, than they would be of liaison on a tripartite basis at the Tactical Air Force level.

(b) The proposal to tie in the U.S. and British representatives in Moscow with SHAFF, may jeopardize the independent position of General Beane.

CLASSIFICATION CHANGED TO SECRET  
EEOB DIA 8206A, 22 SEP 88

NAME DATE

~~SECRET~~ SECRET

0785

~~SECRET~~

(c) So far as coordination of tactical air force operations are concerned, direct contact between the air force commanders (with General Vandenberg representing the U.S. side) is likely to be a far more efficient and satisfactory method than the roundabout and cumbersome procedure of liaison through BRAP and a committee or committees in Moscow.

*General Vandenberg*  
SERGEANT J. HILL  
Brigadier General, U.S. Army  
Director, Post Hostilities  
Planning

~~SECRET~~

0786

re carrier at to D/PH from  
& L Sec, D/PH, 23 Oct '41, subje  
"Liaison with the Russians"

BE/ML/1J

3 Col Lee, D/PH  
P&L Sec, Planning  
D/PH  
Planning

28 Oct

Request you follow up this matter to  
determine:

(a) If proposed cable attached as in-  
closure 2 was sent by SH&EF

(b) What action Combined Chiefs of  
Staff took on this cable

(c) If direct liaison by SH&EF with Moscow  
is approved by Combined Chiefs of Staff, what  
SH&EF personnel are representing that Head-  
quarters.

D/PH

WILLARD LEWIS  
Colonel, Air Corps  
Deputy Director, Post  
Hostilities Planning

336,32

~~FIG~~

[Redacted]

0787

~~SECRET~~~~SECRET~~

373.52

## Liaison with the Russians

381/018

D/PH Planning

1. D/PH Col. 23  
 Planning Lee, Oct  
 P&L Sec. 44  
 D/PH  
 Planning

1. Reference, Top Secret SHAEF letter,  
 OCT NO. 01-1/Plans, dated 10 October 1944,  
 Subject: "Liaison with the Russians".

2. The subject matter of the SHAEF letter concerns an operational requirement for liaison between SHAEF and USSR.

a. The proposed liaison does include provision for coordination of action of tactical air forces and communications.

b. The coordination to be gained through the proposed liaison is essential to efficient operations and there would appear to be no other alternative.

3. The subject SHAEF letter is an intrastaff SHAEF publication and the concurrence of this Headquarters is not essential. However, it is recommended that the paper be forwarded to the United States Group Control Council for General Harper's information.

W. G. LEE, JR.,  
 Colonel, AG,  
 Chief, Policy &  
 Liaison Section

2 Gen Harper D/PH 23 Oct  
 Planning

1. Attention invited to paragraph 1 above.

2. Request return of enclosures when they have served your purpose.

EXEMPTION CHANGED TO SECRET  
 DOC ON 22 MAR 51 BY 54

NAME DATE

MILLARD LEBEL  
 Colonel, AG  
 Deputy Director, Post  
 Hostilities Planning

2 incls:

Incl 1--LTR (r SHAEF, 10 Oct 44, subject  
 "Liaison with the Russians" Top Secret  
 Incl 2--Revised Final Draft (Copy No. 4)  
 SHAEF "Liaison with Russian Forces"

Top Secret - PS SHAEF (44) 39.

FILE COPY

TS-90-

0788

~~SECRET~~Cal LeeSUPREME HEADQUARTERS  
ALLIED EXPEDITIONARY FORCE  
G-3 Division (Main)~~SECRET~~  
Copy No 4

REF. 12-01-1/Plans

16<sup>th</sup> October, 1944

SUBJECT : Liaison with the RUSSIANS

TO : Captain L.A. Shackroy, AEF,  
Group Captain T.P. Cleave, AEF,  
Lieutenant Colonel J.O. Curtis, G-3 Division,  
Colonel W. Whipple, G-4 Division,Copy No  
1  
2 - 4  
5  
6 - 8

1. Since the last draft of SS SHAEN (44) 39 was prepared it has been learnt that a G-3/EMIPUS/RUSSIAN Advisory Committee is likely to be set up in MOSCOW, which includes a member of the RUSSIAN General Staff. This committee, when formed, is likely to be a useful method of liaison with Supreme Headquarters, AEF, in the early stage, before closer liaison on an army group level is required. If we can get liaison on the MOSCOW level now, and remove RUSSIAN suspicions, we shall have a chance of getting the lower level liaison later.

2. I have, therefore, redrafted the paper, shortened it, and attached a draft cable to Combined Chiefs of Staff.

3. Will you let us have your observations or comments on the new draft as soon as possible?

~~Handwritten signature~~  
L.G. MURPHY,  
SOS,  
Chief, Plans Section.

Copies to:-

~~Handwritten signature~~  
P/O  
Brigadier L.G. Moran, G-3 Division,  
Colonel J.K. Wilson, Jr., G-3 Division,  
Secretary, Planning Staff,  
File

Copy No  
9  
10  
11  
12

TS-90

5994

0789

REVISED FINAL DRAFT

SECRET  
Copy No. 4

SUPREME HEADQUARTERS  
ALLIED EXPEDITIONARY FORCE

MEMORANDUM BY PLANNING STAFF

LIAISON WITH RUSSIAN FORCES

1. As the Russian and Allied forces approach each other in GERMANY considerable liaison will be necessary on such subjects as:-
  - a. Coordination of use of operational wireless frequencies, both ground and air.
  - b. Coordination of action of tactical air forces.
  - c. Coordination of repatriation and care of allied prisoners of war as they become uncovered by operations; and coordination of observation and handling of displaced persons. *Exchange of prisoners of war from camps in the Ruhr area.*
  - d. Coordination of military government policies.
  - e. Coordination of local offensives, exchange of plans and of tactical intelligence.
  - f. With particular reference to 'EALISIAN', coordination of the occupation of EALISIA; and of the control of the boundary between the SHAEF and Russian zones in GERMANY.
2. Present arrangements for liaison by SHAEF with the Russian Armies are slow and cumbersome, consisting as they do of communicating with the Russian General Staff through the Combined Chiefs of Staff and the British and US Missions in MOSCOW.
3. It is understood that the Combined Chiefs of Staff are negotiating with the Russians to set up in MOSCOW a committee consisting of one Russian General Staff Officer, one US Officer and one British Officer to act in an advisory capacity. This may improve liaison but does not shorten the channels from the combat point of view.
4. There are two possible lines to take:-
  - a. To set up direct liaison between Army Groups or SHAEF and the Russian equivalents of our Army Groups. This would be the ideal set up in the later stages when forces are in close contact, or under 'EALISIAN' conditions. However, the Russians are likely to be suspicious of such low level liaison - and are likely to insist on everything being referred to MOSCOW for a decision, causing serious delays. Moreover, many of the subjects in the early stages before close contact, are matters which can only be decided in MOSCOW.
  - b. To establish direct liaison between SHAEF and the Russian Army Headquarters in MOSCOW. This would be sufficient during the early stages; would probably be more acceptable to the Russians; would give us a chance to allay their suspicions and pave the way for Army Group level liaison at a later stage.
5. The simplest way to start this liaison would be to obtain authority for SHAEF to deal direct with the British/US Mission in MOSCOW or with the new committee when set up in MOSCOW, on certain specified subjects, as in paragraph 1 above. If necessary, specialists could be sent out as required to the British/US element of the Committee to assist on particular subjects under discussion.

REVISED FINAL DRAFT  
BY SHAEF STAFF

770

FILE COPY

SECRET

TS-90

0790

~~SECRET~~

2.

6. Liaison will become essential from the time the Armas are about 300 miles apart, which is determined by the operating range of the tactical support aircraft.

RECOMMENDATION

7. The planning staff therefore recommend that the Combined Chiefs of Staff be asked to arrange direct liaison between SMALF and MOSCOW. A draft cable is appended (Appendix 'A').

~~SECRET~~

0791



~~SECRET~~APPENDIX 'A'  
to PS BRANT (A) 3 (Plan)

FROM: SHAF

TO: CHIEF OF STAFF

1. Under consideration here is method of obtaining closer liaison with RUSSIAN units as our respective forces approach each other. Subjects on which liaison required include coordination routes of tactical air forces, and of operational air force operations, local problems of prisoners of war and displaced persons, coordination of local operations and plans, and under 'TALIBAN' conditions local problems of entry into BERLIN and coordination of activities along boundary between Supreme Headquarters, AEF, and RUSSIAN zones.
2. As determined by operational range of tactical air forces, closer liaison will become essential when units approach within some three hundred miles of each other.
3. Unrestricted consultative committee of RUSSIAN, US and BRITISH officers to be set up in WSCOM. Best method of initiating closer liaison might be for authority to be given to Supreme Commander, AEF, to deal direct with the BRITISH or liaison in WSCOM or with this new committee when set up. Specialists could be sent from Supreme Headquarters, AEF, to assist US/BRITISH elements of committee on particular subjects under discussion. At later stage, RUSSIANS might be prepared to accept small liaison divisions from Supreme Headquarters, AEF, with BRITISH equivalents of Army Groups.
4. If you agree, request authority to initiate direct communications between Supreme Headquarters, AEF, US/BRITISH liaison in WSCOM and with US/BRITISH elements of the committee in WSCOM, when formed.

  
P/O

0792

373.52

RE/TR/WJ

~~SECRET~~

SECRET

Transmittal of Documents.

1. DC/Ops D/PWP 15 Oct. Recommend this be brought to the attention  
1962 of General Spats.

2 Incl.

1-Ltr. to  
Capt. Thackrey  
2-Memo. by Planning  
Staff Liaison with  
Russian Forces.

EDWARD W. HILL Col  
Brigadier General, U.S.A.  
Director, Post  
Hostilities Planning.

373.52

~~SECRET~~

CLASSIFICATION CHANGED TO SECRET  
DDO DDP 82265, 22 SEP 68

NAME DATE

~~SECRET~~

SECRET

73-90A

0793

~~SECRET~~  
HQ US STRATEGIC AIR FORCES IN EUROPE  
INCOMING MESSAGE  
EDITED LITERAL TEXT

FILE  
373.52

373.52

~~SECRET~~  
710

CLASSIFICATION CHANGED TO SECRET  
DOD DIR 5200.21 SEP 18

NAME DATE

~~SECRET~~

TS-27

5574

0794

**SECRET**  
HQ US STRATEGIC AIR FORCES IN EUROPE  
INCOMING MESSAGE  
EDITED LITERAL TEXT

PRECEDENCE **SECRET**

TO : SAC, [illegible]  
FROM : [illegible]  
SUBJECT: [illegible]

Reference is made to [illegible] dated [illegible] and [illegible] dated [illegible].

30/11-1130  
1

*Reference is made to [illegible] dated [illegible]*

*07*

~~SECRET~~  
PIC

*373.577*

*TS-271*

CLASSIFICATION CHANGED TO SECRET  
DOD OIR 52009, 27 SEP 85  
NAME \_\_\_\_\_ DATE \_\_\_\_\_

THE MAKING OF AN EXACT COPY OF THIS MESSAGE OR ANY PART THEREOF IS FORBIDDEN. IF ADDITIONAL COPIES ARE NECESSARY, THEY WILL BE MADE THROUGH VERSIONS AND WILL BE MARKED WITH THE SECURITY CLASSIFICATION INDICATED HEREON. THE COPY WILL BE SAFEGUARDED WITH THE GREATEST OF CARE.

**SECRET**

6968

0795

~~TOP SECRET~~  
HQ US STRATEGIC AIR FORCES IN EUROPE  
INCOMING MESSAGE  
EDITED LITERAL TEXT

223.52

|           |
|-----------|
| 3914 1620 |
| 9 1 ✓     |
| 1         |

~~PIC~~

373.54

THE MAKING OF AN EXACT COPY OF THIS MESSAGE OR ANY PART THEREOF IS FORBIDDEN. IF ADDITIONAL COPIES ARE NECESSARY THEY WILL BE PREPARED SEPARATELY AND WILL BE MARKED WITH THE SECURITY CLASSIFICATION INDICATED HEREIN. THE COPY WILL BE SAFEGUARDED WITH THE GREATEST OF CARE.

CLASSIFICATION CHANGED TO SECRET  
ODD DIR 82005, 27 SEP 58

NAME DATE

~~TOP SECRET~~

T3-265 144

0796

~~SECRET~~ SECRET

HQ US STRATEGIC AIR FORCES IN EUROPE

INCOMING MESSAGE

EDITED LITERAL TEXT

*1/20/69*

*29/11/68*  
*3*

*0 1* ✓  
*1*

~~SECRET~~  
*PIO*

*373.52*

*1*

THE MAKING OF AN EXACT COPY OF THIS MESSAGE OR ANY PART THEREOF IS FORBIDDEN IF ADDITIONAL COPIES ARE NECESSARY THEY WILL BE MADE  
PHASED VERSIONS AND WILL BE MARKED WITH THE SECURITY CLASSIFICATION INDICATED HEREON THE COPY WILL BE SAFEGUARDED WITH THE  
GREATEST CARE FROM CHANGED TO DELUGA  
DOD DIR 52003, 27 SEP 58

NAME DATE

~~SECRET~~ SECRET

*TJ-204 6950*

0 7 9 7

~~SECRET~~ SECRET  
HQ US STRATEGIC AIR FORCES IN EUROPE  
INCOMING MESSAGE  
EDITED LITERAL TEXT

*extra copy*

|             |          |          |           |  |
|-------------|----------|----------|-----------|--|
| <i>4/11</i> | <i>1</i> | <i>1</i> | <i>91</i> |  |
|-------------|----------|----------|-----------|--|

~~SECRET~~  
*P10*

THE MARKING OF ALL INFORMATION IN THIS MESSAGE OR ANY PART THEREOF IS FORBIDDEN. IF ADDITIONAL COPIES ARE NECESSARY, THEY WILL BE PARAPHRASED VERBATIM AND MARKED WITH THE SECURITY CLASSIFICATION INDICATED HEREIN. THE COPY WILL BE SAFEGUARDED WITH THE GREATEST OF CARE.

READ AND REPORT BY SEP 58  
*4/11*  
NAME DATE

~~SECRET~~ SECRET

*1529d*

0798



~~SECRET~~  
HQ US STRATEGIC AIR FORCES IN EUROPE  
INCOMING MESSAGE  
EDITED LITERAL TEXT

413755

NO MAKING OR AKEARST COPY OF THIS MESSAGE OR ANY PART THEREOF IS FORBIDDEN IF ADDITIONAL COPIES ARE NECESSARY, THEY WILL BE PARA-  
-MATED VERSIONS AND BE MARKED WITH THE SECURITY CLASSIFICATION INDICATED HEREON THE COPY WILL BE SAFEGUARDED WITH THE  
DIR 5206.5, 27 SEP 58

NAME

DATE

~~SECRET~~

43230

0799

From No. 66. 135  
WESTERN UNION  
WESTERN UNION TELEGRAPH COMPANY  
(INCORPORATED IN THE STATE OF NEW YORK, U.S.A. WITH LIMITED LIABILITY.)  
CABLEGRAM  
ANGLO-AMERICAN TELEGRAPH CO., LD. CANADIAN NATIONAL TELEGRAPHS. *us*

---

RECEIVED AT 22 GREAT WINCHESTER STREET, LONDON, E.C.2. (TEL. LONDON WALL 1234.)

K2216 WASHINGTON DC 14 *23* 44 SEP 15 PM 11 07  
NLT EDMUND W HILL US *74*  
6770 AMFUVA LONDON=  
*file*

APPRECIATE LETTER AND CABLE TRANSFER APPROVAL PROBABLE  
AWAITING ORDERS WILL ADVISE FURTHER REGARDS=  
DAVID S KUBIE. *(S)*

Please send your Reply "Via WESTERN UNION" You may telephone us for a messenger

RESTRICTED

U. S. GROUP 2 C  
ARMED FORCES DIVISION  
APO 987

15 September 1944

MEMORANDUM

TO: All Section Chiefs, Armed Forces Division

On Wednesday, 20 September 1944, at 1600, there will be a meeting with Brigadier A. S. Gibson, room 319-A, Norfolk House for the purpose of explaining the functions of the C.S.F.S.

It is desired that all Section Chiefs, and representatives from the Navy and the Air Corps attend this meeting, and in addition, you may designate any other officers from your section to be present.

*J. A. Lewis*  
Brigadier General, U.S.A.,  
Acting Deputy

Distribution:

Ch/Intel Sec  
Ch/Disarmament Sec  
Ch/Demobilization Sec  
Ch/Pa Sec  
Capt. Loyle (USN)  
Brig. Gen. Hill

*Loyle*

RESTRICTED

0801

SECRET

*Plans/ Ops; Combined Bomber Operations,  
Russian Defenses*

1 Dir Plans D/C Ops 1-5-44

It is desired that you prepare a brief which will be a guide for discussion by either General Spaatz, General Knerr, or myself with Marshal Voroshilov in Moscow, or his representative, in regard to our operations and future plans.

If General Spaatz goes he will surely be received by Marshal Stalin, and the brief should take that into consideration.

F. L. ANDERSON,  
Major General, U.S.A.,  
Deputy Commander, Operations.

2 D/C Ops D/Plans 10-5-44

Brief has been completed and was given to General Anderson on 6-5-44.

C. P. CABELL  
Brigadier General, U. S. Army,  
Director of Plans

*Dir Ops Strength  
1-5-44 12-33000  
2-1-44 14-  
1-4-44 14-43000*

SECURITY CLASSIFICATION  
REVIEWED ACC. TO E.O. 11652  
BY 210 250 P/0

SECRET

4 1135

0 8 0 2

~~SECRET~~  
 HEADQUARTERS  
 UNITED STATES STRATEGIC AIR FORCES IN EUROPE  
 Office of Director of Plans  
 APO 633

RAF 586  
 5 May 1944

Notes for Russian Inspection

MEMORANDUM:

TO : Major General Anderson, Deputy Commanding General for Operations.

1. Aim of Combined Bomber Offensive.
  - A. The overall aim of the Combined Bomber Offensive is:
    - (1) Destruction of German Air Force.
    - (2) Destruction of German capacity to resist.
    - (3) Destruction of German will to resist.
  - B. How Proposed Operations Carry Out Aim of Combined Bomber Offensive.
    - A. Necessity of attack against all of Germany.

In order to carry out the above aim most effectively, it is necessary that the entire German economic and war production system be subject to attack by heavy bombers in order that their systematic disruption, disorganization, and destruction be achieved.

B. Establishing a Third Front.

At the present time, operating from two fronts from the west and south, heavy bombers can reach all of the German Reich with the exception of the far eastern and northeastern sections. By establishing a "third front" from Russia, no part of Germany will be immune from attack by the USSTAF and important complementary targets in several general "target systems" could be attacked and destroyed. Appendix A. This selection of targets might well be supplemented by a list which the Russians select as most helpful to them and priority should be given to them in the early missions.

C. Dispersing of German Factories.

Germany, as shown above, still has industrial areas out of reach of heavy bombers from England or Italy. The uninterrupted production from these factories is a vital factor in her power of resistance. If Germany is permitted production in this "safe" area, she will continue and increase the dispersion of her vital factories into that area and greatly increase her undisturbed production of war essentials. A "third front" must be established to prevent this increased power of resistance.

CLASSIFICATION CHANGED TO SECRET  
 DOD DIR 12900A, 27 SEP 59  
 E. H. [Signature]  
 NAME DATE

~~SECRET~~

~~SECRET~~  
 4 1136

0 8 0 3

~~SECRET~~

## D. Exploiting Mobility of USSTAF.

The above plan will most effectively exploit the extreme mobility of the USSTAF by forcing the Germans to further disperse their limited operational fighter forces and anti-aircraft defenses. With no surplus at present, such a dispersion will cause a decrease in defenses over any one given area and make the whole Reich more susceptible to attack.

## 3. Supplementary Operations.

## A. Constructing Heavy Bomber Bases.

(1) Plans for and construction of three operational heavy bomber bases in the Kiev area are nearing completion. Appendix B. A.T.C. Report.

(2) Station personnel have been moved in and established and supply lines have been arranged to supply the bases on a 60 day operational reserve level for a proposed 800 bomber sorties per month from these bases.

## B. Fighter Escort.

(1) As the number of German fighters are moved into this eastern area, the necessity for long range fighter escort correspondingly increases. Russia has consented to assist in this escort, but the difficulty of the assignment must be impressed upon her. General Spaatz arranged while in the Mediterranean that one U. S. fighter group would be included in initial force.

(2) Russia, at the present time, does not have a single long range fighter even remotely comparable to the present high altitude bomber escorts used by the USSTAF.

(3) The operation also requires the ultimate in cooperation and timing, and Russia has had no experience in such procedures.

## C. P.R.U.'s.

(1) In order to carry out the above plan, it is essential that complete photographic coverage be obtained for the proposed target areas as well as other areas when they are not open from the west.

(2) The Russians do not have the information necessary, or at least have not provided it, and seem to have no organization capable of obtaining the necessary information.

(3) P.R.U.'s will soon be established and operating in Russia to provide the necessary targeting material. They will be based on and operate from one of the three heavy bomber bases which are now nearing completion near Kiev.

(4) These P.R.U.'s will be used for both American and Soviet reconnaissance and all information obtained should be equally accessible to both parties, thus providing mutual benefits.

~~SECRET~~

4 1137

0 8 0 4

~~SECRET~~

4. Benefits Derived for Future Operations.

A. Psychological and Morale Factors.

(1) In the proposed operations, a precedent would be established for American-Soviet cooperation.

(2) The effectiveness of high altitude precision bombing by the USSTAF would be established.

(3) Targets could be selected and operations planned with the full cooperation of the Russians to the end that they would provide mutual benefits.

(4) The above mentioned items would tend to greatly increase international unity and agreement between Russia and the U. S. and establish relations very satisfactory for further cooperation.

B. Other Factors.

(1) The initial military and political contacts have been made and a knowledge has been gained of Russian political and military procedures which would be of great assistance in promoting further contacts and good will.

(2) If it should prove desirable and acceptable to enlarge the U. S. forces in Russia, the personnel now obtaining practice and training in the special techniques required in connection with operations in Russia ~~and~~ would prove very valuable in that expansion.

5. Command Problems.

General Lareen should be considered the Air Force Commander and should be stationed in Moscow. He would work through General Deane as necessary. Colonel Kessler would be the Combat Wing Commander.

C. P. CABELL,  
Brig. Gen., U.S.A.,  
Director of Plans

~~SECRET~~

4 1138

-3-

0 8 0 5



~~SECRET~~

DRAFT

FUTURE OPERATIONS AGAINST JAPAN

1. Aids:

The aid is first to obtain Russia's assurance that she will cooperate in the employment of USSTAF from Russian bases against Japan when the time comes. Next it is to lay the groundwork now which will lead to the most effective use of this air force. We therefore now only seek information upon which to base decisions as to size and type of forces deployable, supply arrangements, necessary, etc. We seek the opportunity to develop facility in cooperation between us and the Russians.

2. Forces:

What size and composition of forces? Would U. S. fighters be needed for escort? For local defense?

3. Bases:

To what extent will bases be available? Where? Type? Who will construct them? When? Will bombers and fighters be based together?

4. Supply and Movement:

What size force could be sustained?

What would be the supply routes?

What would be the routes for movement across Russia?

What particular element of supply would be limiting factor, if any?

5. Personnel:

Would the practice be continued of having the Russians provide the majority of ground personnel? This would be undesirable to U. S. What conditions would be imposed by Russians if this restriction were lifted?

~~SECRET~~  
PIC

~~SECRET~~

4 1133

0 8 0 6

COPY

~~SECRET~~

PROPOSED LIST OF TARGETS

Appendix "A"

- GDYNIA - It is the location of the two Kanneberg aircraft components and assembly factories which form a valuable contribution to German F.W. 190 fighter aircraft production. It is also a Baltic Sea port which is the base of some of Germany's most important naval installations and units.
- KREISING - Location of one of the most important factories in the production of F.W. 190 fighter components.
- POSEN - It is here that Focke-Wulf has a large aircraft factory which furnishes components to the various assembly points of the F. W. 190 Eastern Complex.
- SORAU - Location of several small components factories and an assembly plant which together represents valuable portion of F. W. 190 fighter aircraft production.
- BLECH-HANBER - Location of two of the enemy's largest synthetic oil plants.
- PILSEN - Location of the Skoda works - one of the largest armament manufacturers in the world.
- OSWIECIM - Location of a very large new synthetic oil and synthetic rubber plant.

4 1140

~~SECRET~~  
0807

~~SECRET~~  
SECRET

CHRONOLOGICAL RECORD OF "FRANTIC" PROJECT

- Feb.
- 6th Col. J. S. Griffith (Director of Maintenance) appointed C.O. for Project.
  - 8th Conference at General Spaatz's quarters outlines mission.
  - 9th Col. W.P. Youngs appointed co-ordinator for ASC planning in U.K.
  - 10th First joint staff meeting to furnish personnel and materiel for 200 B-17's per mission, four missions per month, plus 60 PRU sorties per month by P-38's. Supplies based on 30-45 day level for three airdromes.
  - 16th Detailed plans book completed.
  - 17th Col. Griffith and party departed by B-17 for Moscow. (First Echelon).
  - 20th Gen. Knerr directed 250 personnel be sent by air. (Third Echelon).
  - 25th Col. Griffith arrived Moscow.
  - 29th Second Echelon consisting of key staff officers ready for departure (awaiting Russian visas).
- Mar.
- 3rd Gen. Knerr directed total personnel be readied.
  - 13th Third Echelon (33 officers and 220 EM's) started moving via ATC.
  - 15th Second Echelon departed in one C-47 and one CB-24.
  - 20th Five cargo ships with supplies and 6 Transportation personnel left U.K. for Murmansk.
  - 24th Second Echelon arrived Moscow.
  - 25th Fourth Echelon (71 officers and 681 EM) departed U.K. via sea transport for Cairo. Will proceed from there by air.
  - 26th Diplomatic arrangements completed for AAF personnel to enter Russia without individual visas.
  - 28th Soviets authorized 30 trips by ATC into Russia from Teheran.
- Apr.
- 2nd Movement of Third Echelon from Cheddington completed.
  - 3rd Received War Department approval of future supply plan.
  - 5th Authority received for supply of aviation gasoline and oil from Abadan.
  - " Temporary camp supplies for Third Echelon started by rail from Teheran for Poltava. North convoy arrived at Archangel.
  - 9th War Department approval received for designation of Col. L.B. Hickam as Air Service Commander.
  - 10th Movement of Fifth Echelon (34 officers, 165 EM) started via ATC.
  - 12th Col. Griffith in B-17 departed Teheran for U.K.
  - " Fourth Echelon arrived Port Said.
  - 14th Gen. Deane concurred in need for 30 additional interpreters.
  - " Col. Kessler and Staff moving to Poltava.
  - 16th First train of supplies left Murmansk for Poltava.
  - 17th Griffith arrived in U.K. from Moscow.
  - 22nd Staff Engineer and 8 AACS personnel, first contingent of Third Echelon, departed from Teheran for Moscow in C-47. (Russian crew).
  - 23rd First contingent of Fourth Echelon (35 officers, 375 EM) departed Cairo for Haifa.
  - 27nd Col. L. B. Hickam, Air Service Commander, departed via ATC for Poltava and Moscow.
  - 28th Last contingent of Fifth Echelon, except 25 interpreters, departed U.K. via ATC.
  - 30th Two C-87's and one C-47 left Teheran for Poltava, carrying priority cargo. 42 additional trips for movement of personnel of Third and Fifth Echelons and cargo approved.

~~SECRET~~  
SECRET

As of 1300 hours 2 May.

4 1141

0 8 0 8

Appendix "B" (Cont)

~~SECRET~~ SECRET

CONTINUING PLANS

1. Priority material being forwarded by ATC.
2. Supplies to be shipped from U.K. for 60-day level on basis of 800 B-17 and 60 P-38 sorties per month being assembled to go on 23 May convoy to arrive Persian Gulf 27 June. Additional supplies being furnished from U.S. will arrive Persian Gulf Ports not later than 15 June.
3. Subsequent supplies will be requisitioned on PGC, except: Air Corps supplies, which will be requisitioned on U.K.; HM bombs and ammunition to be supplied by Soviets; PGL supplies to be furnished from Abadan.
4. Fourth Echelon scheduled to reach Hasadan 6 May. Movement from Hasadan to Tabriz will be by truck, to arrive 11 May. Onward movement from Tabriz being handled by Russians. Will arrive Poltava about 15 May.
5. Fifth Echelon movement from U.K. via ATC scheduled to be completed 10 May; tentative approval received to move Fifth Echelon via ATC C-37's from Teheran to Poltava.
6. Based on Reconnaissance report, anticipate use of fields at Poltava, Mirgorod and Dnyatin.
7. Estimated that all supplies from North convoy will be delivered at the bases by 20 May.
8. Housing facilities for 900 bodies will be provided at each base.

As of 1300 hours, 2 May.

~~SECRET~~ SECRET

4 1142

0 8 0 9

Appendix "B" (Cont.)

~~SECRET~~SUMMARY OF ASC PREPARATION FOR "FRANTIC"

1. Air Service Command planning for the "FRANTIC" Project was predicated on the assumption of 800 B-17 sorties per month, plus 60 PRU sorties by four P-38 aircraft per month, using three airdromes. An unknown amount of assistance in men and materiel would be provided by the Soviets.
2. Personnel to man the bases in Russia was moved in five echelons:
  - a. First Echelon--Colonels Griffith, Kessler and Cullen departed from the U.K. on 17 Feb., in a fully operational B-17 and arrived Moscow on 25 Feb.
  - b. Second Echelon consisting of 9 key Staff Officers and 1 EM, departed the U.K. 15 March by air, after waiting three weeks for visas, and arrived Moscow 21 March.
  - c. Third Echelon consisting of 31 officers and 219 EM, began departure Cheddington 17 March via ATC, through to Russian Base Areas.
  - d. Fourth Echelon consisting of 71 officers and 680 EM, staged at Stone, departed by surface vessel from U.K. 29 March and scheduled to arrive at Port Said 12 April; will be transported overland from Port of Debarkation to final destination.
  - e. Fifth Echelon. Departure began via ATC 11 April, and will consist of approximately 34 officers and 165 EM. Will complete personnel requirements to date and was necessitated by development of plans from our staff in Russia as well as replacements for personnel disqualified on previous echelons.
  - f. Three officers and 3 EM accompanied the shipment of supplies via North convoy departing U.K. 21 March.
  - g. Two Weather Officers have been assigned from the 15th Air Force; to proceed directly from Italy to Teheran. Concurrence from Kessler has been received for the shipment of 30 additional officers and men to act as interpreters. The total number of bodies presently assigned to the "FRANTIC" Project is 1221. (See Appendix "C").
3. Initial supplies and equipment were shipped in 5 Liberty-type vessels in a convoy which cleared U.K. ports 21 March and arrived Archangel 5 April. Approximately 3 weeks required to tranship to base areas. Materiel unavailable for loading on 21 March convoy is being transported by ATC and will arrive at base areas on or before 10 May. (60,000 lbs.) These shipments consisted of all type supplies and equipment required to support the operations for 30 days.
4. Supervisory personnel, supplies, and equipment dispatched provide the following services and facilities:

~~SECRET~~

- 1 -

4 1143

0 8 1 0

Appendix 7 (Cont)

~~SECRET~~ SECRET

a. Maintenance: First, Second and limited Third and Fourth Echelon will be accomplished. The extent of accomplishment of the above will be governed by our ability to utilize the personnel furnished by the Russians (Airplane and Engine Mechanics, Assistant Crew Chiefs, Sheet Metal Workers, Fabric Workers, and Propeller Specialists).

b. Ordnance: High explosive bombs and ammunition necessary for 30 days' operation have been supplied. 250 lb. HE bombs were substituted for 500 lb. HE bombs because of acute shortage of the latter at shipping date. A limited number of vehicles are provided and will be augmented by vehicles furnished by the Soviets.

c. Chemical: On a basis of 50% of the sorties carrying incendiary bombs, a 30-day supply of M-47A2 100 lb. incendiary bombs with all accessories is provided. Provision for chemical defense of permanent and casual personnel has been made.

d. Signal: This Headquarters in conjunction with Signal Airways Service, and Army Airways Communication System, is providing:

- (1) Radio Range: For long range navigational aid.
- (2) Long Range Radio Circuit: For operational, administrative and weather communication between Russian bases, U.K., and Caserta.
- (3) Airdrome Control: On 6440 Kc. ("darky"), and common VHF channels. Redline radio system also available for long range control of aircraft.
- (4) Compass Location Stations: Compass beacon each airfield.
- (5) Direction finding facilities: One VHF/DF Station provided at a Russian base for operations of PRU aircraft. VHF/DF facilities for each airfield. HF/DF equipment for bombers.
- (6) Wire facilities: Internal telephone communication on each base; also field-to-field wire circuits.
- (7) Local point-to-point radio: By supplementary radio net linking the three bases.
- (8) Additional facilities: Equipment on order from the U.S. will provide (a) standby or supplementary long range point-to-point channels, (b) long range compass homing stations, (c) long range air-to-ground channels for operational control.

e. Quartermaster: Class I, II, III, and IV supplies are provided for permanent and casual personnel.

~~SECRET~~ SECRET



Appendix "B" (Cont.)

~~TOP~~ SECRET

I. Engineer: 12,000 tons of steel plank provided for conditioning airdromes. Portable housing and storage building being investigated for use during winter months starting 1 October.

K. Medical: one 100-bed field hospital has been provided for each airfield. Special consideration has been given to disease peculiar to the area. A C-47 hospital ship has been loaned to the Soviets and will be operated by them for evacuating wounded from bomber bases to Teheran.

5. Supplies for additional 60 days' operation are now being assembled for shipment in a convoy departing U.K. 23 May, except the following items:

- A. Aviation gasoline and aircraft engine oil to be supplied from Abadan.
- B. Incendiary bombs to be supplied direct from the U.S.
- C. HE bombs and .50 caliber ammunition to be provided by the Soviets.

6. The plan for Maintenance supplies for the Project after the 90-day period provides for direct requisition on the Persian Gulf Command for all items except (a) Air Corps technical supplies which will be requisitioned on the U.K., (b) aviation gasoline and aircraft engine oil to be furnished from Abadan, (c) HE bombs and ammunition to be provided locally.

7. Investigation has revealed that most supplies to be requisitioned on the FGC are presently available. Those items not available in that area will be requisitioned by the FGC directly on the U.S. The above supply plan had been approved by the War Department and is concurred in by Gen. Deane and CG, FGC.

8. The Soviet organization at each base will include a Technical Battalion, Service and Housekeeping Battalion, and a Truck Battalion; total personnel approximately 1,400. Movement of this personnel to the bases started the last of March. Construction of runways, buildings, and facilities on the airdromes will be accomplished by Russian personnel under the supervision of the American Engineer personnel. These Soviet units will remain on the bases to provide housekeeping and guard details, and to render all assistance for which they are qualified. Bases have been selected at Poltava, Mirgorod and Piryatin. Reconnaissance of these bases revealed that practically no facilities are at present extant.

~~TOP~~ SECRET

4 1145

0 8 1 2





0 8 1 3



0 8 1 4



0 8 1 5



0 8 1 6

522.162-4  
44/07/24 - 1. 45  
44/09/25  
RETURN TO  
AFSHHC  
MAXWELL AFB AL 36112

5-2-47

7/5 message, withdrawn from folder  
Message message folder in box 11, 10/19/62

1029162

DECLASSIFIED  
EO 13526

0817

AIR

25 September 1944

M 21114

HQ. MAAF.

Walsh.

Message not recognizable

RJ

WALTON DEANE

Zinkand

~~XXXXXXXXXX~~

ZS1910Z

O. P.

TO: HQ. MAAF, signed DEANE.

Cannot recognize your message JW 126 IE dated 24 September  
by that number consequently your message JD 21 IE cannot be understood.

|   |                                  |
|---|----------------------------------|
| RETURN TO<br>AFSHIC<br>MAXWELL, AFB, TEX. | 522.162.6<br>44/07/24 - 44/09/25 |
|---|----------------------------------|

~~RECEIVED  
BY  
DATE~~

CLASSIFICATION CHANGED TO  
 E.O. 13526, 27 SEP 58  
 NAME:                      DATE:                     

1029162

0818



25 Aug 44

ACMAH, Washington  
Hq MAAF, Caserta

FRANTIC Expansion

Doane

Priority

~~TOP SECRET~~Amb:  
Hq:  
Army:  
Air: ✓

MX-20701

JRD

JWS

Carter

~~TOP SECRET~~251207Z  
251140Z

To ARNOLD information to BAKER for SPAATE at Caserta from DEANE TOPSEC

The Ambassador has received an informal advance indication from Molotov that an expansion of FRANTIC will not be approved at this time. Molotov stated that shuttle operations in the winter months will be impracticable and suggested that the bases be returned for Russian use.

I shall see Nikitin upon his return to Moscow in a day or two and hope to get a frank statement from him as to what is back of the Russian attitude. I shall be able to make definite recommendations after I have seen him.

I do not believe that winter operations from the Russian bases are impossible or impracticable. However, the tactical and strategic advantages assume decreased importance with the possibility of early establishment of bases in France and possibly in the Po Valley, together with capitulation of Rumania. Unless ESCOM is prepared for rugged living in dugout-type construction, complete winterization of the present three bases would be a project of questionable value.

The Ambassador and General Walsh feel the best solution at the moment is to maintain one base at Poltava throughout the winter for FEU operations, such small-scale shuttle bombing operations as the weather permits, for storage of material, and as a springboard for

~~TOP SECRET~~  
REVISION 1, SEC ARMY  
10 FEB 93 R

DATE 3/10/93  
DATE 3/10/93

~~TOP SECRET~~

0819



~~SECRET~~

future operations. This would retain the political and psychological advantages which accrue from FRANTIC. I concur with this view provided it can be effected after frank and friendly discussion with the Russians resulting in an understanding that we can resume larger scale operations in the spring at bases further west if desired.

Walsh is discussing the situation with Spetz at Caserte who will undoubtedly submit recommendations to you. Meanwhile, would appreciate your views on what you would like to have maintained here. Suggest that a firm decision be deferred until after you have heard General Spetz's recommendations and the results of my discussion with Nikitin.

~~SECRET~~

26 September 1944

Hq MAAF CASERTA

Target Objective

Walsh

Priority

Hq 1

Amb 1

Air 1

USCIB

*M 21116*

~~SECRET~~

To WAKER from WALSH signed DWAGE:

Following up your RS 1924 of September 19 and our reply M-Z 064 of September 22 had conference with Red Air Staff on September 23 and was assured would be given immediate reply reference this target. No reply yet received. Message was given to Soviets as you worded it. Suggest you reinstate target on your list until Russian front line as reported by USCIB is within 50 miles or until Soviets make specific request to delete. Will notify Soviets to this effect. From our information target is about 70 miles from front.

~~SECRET~~  
 BY 122 FEB 23 R 30

CLASSIFICATION CHANGED TO SECRET  
 GDC DIR 8200.8, 27 SEP 88  
 NAME \_\_\_\_\_ DATE \_\_\_\_\_

0 8 2 1

22 September 1944  
HQ MAAF, Caserta  
Conference with Krolenko

Asst:  
Sgt:  
Capt:  
Supt:  
Air: ✓

1121064

Breese

Cartier

~~Routine~~

~~SECRET~~

~~SECRET~~

To GENERAL RAGER from WALSH signed DEANE

For two days have requested conferences with General Krolenko of Red Air Force Operations Section and so far no answer. Request in your JW-122-IE now being forwarded in letter.

~~SECRET~~  
12 SEP 28 1944

~~SECRET~~

CLASSIFICATION CHANGED TO SECRET  
SEC. DEF. REGS., 27 SIM 52

1 (END)

0 8 2 2

22 Sept. 1944

AGHAN, Washington  
Supplies to Insurgents

Deane

Sooooo

Amb  
Eq.  
Gas  
Supply  
Air

Priority

~~Top~~ Secret~~TOP SECRET~~

To ARBOLD info SPAATE signed DEANE

Representative Soviet General Staff informed me that Soviets have been dropping food to Polish insurgents in Warsaw for the past 6 nights and that they will continue to do so as long as is necessary. He stated that he felt their efforts were sufficient to satisfy the Polish needs in Warsaw as far as food is concerned. I asked through the interpreter if the Soviets were dropping only food and the reply was that this was the case. However, press reports have indicated that they are dropping ammunition as well, and it is suggested that this might be clarified by requesting information from the Polish Government in London.

Soviet Representative General Staff stated that both British and Americans were flying at such high altitudes that at least 50 per cent of supplies dropped fell into the hands of the Germans and suggested that if further flights were made corrective action should be taken. He stated that Soviets dropped food from altitudes of 1500 to 2000 feet. While he did not indicate the size of their formations, he did say that they are small and that only light aircraft were used. This in reply to your WAR 33668 of 20 September 1944.

RECLASSIFIED BY 100-108 P 3  
CLASSIFICATION CHANGED TO SECRET  
DOD DIR 2300A, 22 SEP 88

NAME DATE

0 8 2 3

21 September 1944  
HQ USSTAF, London  
AGWAR, Washington  
Supplying Polish Insurgents

Amb:  
Hqs:  
Air: ✓  
G&S:

Deane

White

Routine

~~SECRET~~

~~SECRET~~

To SPAATZ information copy to GENERAL ARNOLD from DEANE.

General Arnold refers to an article in the New York Times indicating that the Red Air Forces have been dropping supplies to the Polish Patriots in Warsaw for the past week. He asked me to obtain official confirmation which I am trying to do. Meanwhile, it might be quicker if you could obtain this information from the Polish authorities in London and send it on to General Arnold.

CLASSIFICATION CHANGED TO SECRET  
DDO DIA 2200 & 22 SEP 58

NAME \_\_\_\_\_ DATE \_\_\_\_\_

SECURITY CLASSIFICATION  
R 30

~~SECRET~~

1 (END)

0 8 2 4

Hq, MAAP, Caserta

RS 1924

Operations

10 Sept 1944

amb    Hq    Gas    Sply    Air   

191707A

~~SECRET~~ SECRET

Type

~~Secret~~

741

WALSH (R) DEACT. > SEC.

Trasobina Altrad "Bynia Refinery 50°05' North 15°27' East believed to be active again and we would normally reinstate on list of targets for attack.

2. Request you point this out to Russians and suggest to them that in light of approach of their armies this area they may wish to attack this target since timing of such attack by them could be better coordinated with their advance. Highly desirable production this refinery be denied enemy.

3. In event no attack contemplated by Russians we will consider attacking. It is necessary however that we be advised as far ahead as possible of Soviet intention and bomb line to preclude attack when occupation by Russian forces imminent.

*Active Area*

CLASSIFICATION CHANGED TO UNCLASSIFIED  
DATE 08/25/00 BY SP4 JAC/STW

NAME DATE

~~SECRET~~ SECRET

0825

6 September 1944  
Hq USSTAF, London  
ACWAR, Washington  
Swedish Ball Bearings

Asst :  
Hq :  
Army :  
Air : ✓

11-20864

Deane

Carter

Routine

~~SECRET~~

~~SECRET~~ SECRET

For SPAATZ repeated to ARNOLD for information from DEANE TOPSEC  
Ambassador received instructions from State Department today  
that no further approach was to be made to the Soviet Foreign  
Office in regard to the transportation of Swedish ball bearings  
to the Soviet Union.

CLASSIFICATION CHANGED TO SECRET  
DATE 27 SEP 58  
NAME

~~SECRET~~  
R 30

~~SECRET~~ SECRET

1 (END)

0 8 2 6



5 September 1944  
Hq USSTAF, London  
FRANTIC Operations  
Deane  
Routine

Amb :  
Army :  
Eqs :  
Air : ✓

White

~~SECRET~~

~~SECRET~~ SECRET

For SPAATZ from DEANE TOPSEC

Ambassador, Walsh, and I are gratified to learn that FRANTIC SIX has been determined upon and that FRANTIC SEVEN is in prospect. To correct impression given in our number MX-20821 of 5 September that Mr. Harriman wanted only one more mission, we believe that the maximum use should be made of present bases as long as weather permits. Assuming Soviet concurrence, we believe that additional missions which can be justified tactically and strategically will strengthen our position with the Russians.

~~SECRET~~  
REVISIONS BY TAG 981 R 31

~~SECRET~~ SECRET

1 (END)

CLASSIFICATION CHANGED TO SECRET  
DDG DIR 8106.9, 27 SEP 88

NAME DATE

0 8 2 7

~~SECRET~~

HQ USSTAF, London

UX-67541

Frantic - Operations

4 Sept 44

Amb    Air  Army    Hdqs    Supply   

04/1240Z

JM

04/0926Z

White

~~SECRET~~

491

OPERATIONAL PRIORITY

To WALSH information WALTER DEANE signed SPAATZ cite DEANE'S MX-20821  
September 3.

Already planned is FRANTIC SIX and consideration being given for  
SEVEN. Flight plan for number SIX not repeat not filed as yet because  
of weather immediate future. You can expect this flight plan any time  
from now on.

New subject: In view of foregoing desire that no repeat no breakup  
of EASTCOM organization take place prior to 15 September in any case, and  
only on notice from this headquarters after that date mentioned.

*air*~~SECRET~~

CLASSIFICATION CHANGED TO  
TOP SECRET, 22 SEP 44  
DATE

1 (END)

~~SECRET~~

0 8 2 8

3 September 1944

Hq WCCOM, Poltava  
Hq USSTAF, London  
Operations - FRANTIC

Amb \_\_\_\_\_  
Air \_\_\_\_\_  
Army \_\_\_\_\_  
Hdqs \_\_\_\_\_  
Supply \_\_\_\_\_

*MX 20821*

Walsh

White

OPERATIONAL PRIORITY

~~SECRET~~ SECRET

To SPARTI information WCCOM from WALSH signed DEANE. TOP SECRET.

Harriman believes if practical that we should attempt one more shuttle operation by 8th Air Force prior to readjustment WCCOM for winter activities. There is no indication of Soviet approval of this mission and usually we do not ~~know~~ <sup>Receive</sup> answer until direct request is made for clearance.

1

~~SECRET~~  
H 30

CLASSIFICATION CHANGED TO SEC.  
DOD DIR 52009, 27 SEP 58

NAME \_\_\_\_\_ DATE \_\_\_\_\_

0 8 2 9

27 Aug 1944

Kurmansk

Northern Convoy

Send

PRIORITY

~~SECRET~~ SECRET

Amb \_\_\_\_\_  
Hq \_\_\_\_\_  
Army \_\_\_\_\_  
Supply \_\_\_\_\_  
Air

Phillips

290030

~~SECRET~~ SECRET

To FRANKS for BRUCKER from McHENRY signed DEANS.

Late information indicates that northern convoy being split and that the major portion of those ships on which ESCOM supplies are loaded will dock at Archangel. Captain Vincent is being sent there.

At your discretion, and when necessary work at Kurmansk is finished, suggest that you and Lasarchuk may desire to proceed to Archangel and coordinate work there with Vincent, Harshaw, and Soviets until finished.

Will keep you posted on developments.

CLASSIFICATION CHANGED TO SECRET  
RSD DIR 2500.2, 27 SEP 58

NAME \_\_\_\_\_ DATE \_\_\_\_\_

~~SECRET~~ SECRET

0 8 3 0

~~SECRET~~Kessler

1 June 1944

AGWAR, Washington  
Milattache, Amembassy, London

FRANTIC Operations

Deane Carter

PRIORITY

~~SECRET~~

*Gen Marshall and Gen Arnold*  
For Joint Chiefs-of-Staff for their eyes only and repeated to General Speatz for his eyes only from DEANE TOPSEC.

In his message number 13113 of 26 May General Speatz indicated that for the first FRANTIC missions it was desired to attack targets at Gelatz, Mielec, and Riga with alternate targets as the marshalling yards at five different localities. These proposals were submitted to the Red Army General Staff for approval and were finally disapproved by them on May 30. I had a long argument on the subject previously reported to General Arnold.

Early this morning I was again called by the Red Army General Staff for a discussion of the subject of targets. They were concerned that our operations might interfere with some of the plans for their ground and air operations. This seemed to be particularly true in the area south and east of Riga. They wished to know if we would be willing to change our plans if they informed us that our operations would interfere with their plans, also if we would be willing to attack targets on their request in order to assist them in their plans. Finally, they wanted a clearer interpretation of our conception of the temporary bomb line established

CLASSIFICATION CHANGED TO SECRET  
DOD ON 11/26/93 BY SP-4

NAME

DATE

Page 1

0831

in the Balkans. They have looked upon this line as being extremely rigid. I emphasized that the bomb line was temporary until adequate liaison could be established, but that even while the line existed we would be perfectly willing to have them operate west of it provided we were informed of their intentions and did not have plans to operate in the same area at the same time. General Slavin indicated that the General Staff was reconsidering their disapproval of our original request, and I rather expect that they will withdraw their objections to our hitting the targets at Galatz, Mielec, and perhaps at Riga. In the future I think it would be well if we would simply inform them of our plans as far in advance as possible without asking for specific approval, always being ready with alternative objectives if they request us not to attack a certain target for specific reasons.

General Slavin asked me to express these views in a letter to him. I have therefore written him a letter and present a paraphrase of it as follows. Request that you either confirm the views which I have expressed in the letter or instruct me as to how you wish the letter to be altered.

~~SECRET~~ SECRET

(M132)

Page 2

0 8 3 2

1

May I inform you in confirmation of our conversation of last night that the United States Chiefs of Staff earnestly desire to utilize United States aircraft to assist the advance of the Red Army to the fullest possible extent consistent with carrying out the American part of the combined bomber offensive.

The United States Chiefs of Staff also desire to avoid any action which will interfere with the operational plans of the Red Army. For this reason, we shall inform you of all targets which we propose to attack when operating from Russian bases or when operating to and from Russian bases as soon as they have been decided upon. Should you indicate in sufficient time that an American air attack on one of our proposed objectives will interfere with the operations of either the Red Army or the Red Air Force, I am certain that our attack will be shifted to another objective until your objections are withdrawn.

I have always felt that the temporary bomb line now established in Rumania is unnecessarily restrictive to both sides. May I therefore suggest that we try to arrange a Soviet-British-American agreement to establish close and daily liaison in Moscow in connection with Balkan air operations.

Page 3

(M 132)

0 8 3 3



~~SECRET~~

Colonel Gornly in Poltava has been sent to the USSR to serve as a liaison officer from the Anglo-American Mediterranean Air Forces. If the Red Army General Staff could select someone to meet with him daily, I believe it would be possible to do away with the temporary bomb line and effect coordination exclusively through liaison. We now have adequate communications between Moscow and Caserta for this purpose.

Because these matters are of such importance, I request that you do not take the views that I have expressed in this letter as commitments until I have had an opportunity to obtain confirmation from the United States Chiefs of Staff. I shall cable them today requesting such confirmation."

~~SECRET~~  
(M132)

Page 4 (END)

0 8 3 4

TOP SECRET

11 Aug 44  
 HSCOM, Poltava  
 POC, Teheran  
 Frantic Operations

Amb \_\_\_\_\_  
 Sq \_\_\_\_\_  
 Army \_\_\_\_\_  
 Supply \_\_\_\_\_  
 Air \_\_\_\_\_

MX 20777

McHenry Miller

Priority

~~Secret~~ Secret

To Walsh for Kessler from McHenry signed Leane info Connolly for  
 Walsh ~~SECRET~~

For your information, I quote Arnold to Leane WASH 88417, 30 August:  
 "Answered in your MX-20730, dated 28 August 44 by our WAB-88057,  
 dated 28 August 1944, which crossed currents and which concurs with  
 SPAATS proposal to reduce frantic operation to one base with 200 American  
 personnel. This is not to be construed as limiting personnel to this  
 number, in view of the 300 figure mentioned in your message. Advise  
 soonest possible Soviet Government's reaction to this proposal."

Concurred in by Spaats and Arnold, it has been proposed to Soviets  
 that after 1 November operations be restricted to one base, preferably  
 Poltava, for purpose of maintaining photographic reconnaissance through  
 the winter to care for American equipment now in Russia, and reduced  
 scale shuttle operations such as weather ray permit, and as a base  
 from which to resume larger scale operations in the spring if desirable,  
 and to be authorized a total personnel after 1 November of about 300.  
 Soviet concurrence has not yet been received. However, proposal is in  
 keeping with previous discussions with them regarding winter curtailment.

New Subject: Soviets told yesterday we will have no further  
 requirement bombs and aviation gas beyond that presently assigned, and

CLASSIFICATION CHANGED TO SECRET  
 DOD DR 11004 21 SEP 78

~~SECRET~~ SECRET

Page #1

0 8 3 5

~~TOP~~ SECRET

supplies at northern port other than hutments and approximately 10 tons Special Service supplies would be given them on Lend Lease, and the balance returned to England.

New Subject: Reference JN-2116, 31 August, due to other urgent matters, General Spalding may not be able to leave for Paltava on 1 September. Will advise later.

New Subject: Have been advised entry visas Walsh and Breeze in order. Continuing effort to clear same for Weis.

2 (100)

~~TOP~~ SECRET

0 8 3 6

28 Aug 1944

ESCOM, Poltava

Termination; Explor-  
ation Op; Supplies  
McHenry

Priority

Amb \_\_\_\_\_  
Hq \_\_\_\_\_  
Army \_\_\_\_\_  
Navy \_\_\_\_\_  
Air

Green

~~Secret~~

~~SECRET~~

To Walsh for Kessler from McHenry signed Deane ~~SECRET~~

This message received from Spatz paraphrased for your information:

\*AD AX 185, 27 August 1944, from Hq MAJF 880 from Spatz for Deane and Harriman.

Spatz agrees we should continue with a detachment in Russia preferably at one base. This in conference of Spatz, Baker, Knerr, and Walsh. We should request Soviet authorization to keep 300 personnel with an actual 200 contemplated. This detachment to be utilized for PMU operations, special or emergency operations, and for care of equipment pending possible Spring operations. An abrupt cessation of activities would thus be eliminated as well as eliminating termination being taken as an incident.

New Subject supplies for Soviet bases. Have asked Arnold's concurrence, and he will inform you direct in reference to supplies on Northern Convoy. Special service supplies and 39 hutments are all that are believed should be unloaded.

New subject exploration operations. Independently there is feeling here that we should not attempt to divert supplies needed in other theaters to exploration project, because project may be eliminated due to the time element as result of present Pacific advances. Same feeling

RECEIVED  
17 AUG 31 1944  
COMMUNICATIONS SECTION  
HEAD QUARTERS  
AIR FORCE  
WASHINGTON  
D.C.

~~SECRET~~

~~SECRET~~

1

E

R 30

0 8 3 7

~~SECRET~~

as indicated to you by Knerr indicated here.

Bombs and aviation gasoline now consigned to bases for our use is all we need. Please inform Soviets. Request you have at Teheran by 30 August information on plans for Walsh's B-17. He will be in Teheran 30 August. Reentry visa for Walsh for 31 August is requested."

New Subject: In view of above, suggest consideration immediate movement out of Russia of sufficient personnel to allow visas for 44 ferry personnel, reference your T 341 August 27. If not feasible inform me immediately and I will initiate action to obtain additional visas.

New Subject: Assuming Arnold's concurrence in above paraphrased cable, markings for return of GCI equipment have been requested. We are giving instructions to Brekke at Murmansk and Vincent at Archangel to move 39 barracks and special service supplies to Poltava. Our records do not include steel netting on this convoy, and General Knerr indicated when here that it had not been shipped.

~~SECRET~~

~~SECRET~~ SECRET

New Subject. Just received your JK 2363, August 28, and unless you have further information, will not forward, as instructions have already been sent to Brekke at Murmansk and Vincent at Archangel, same effect except to ship recreation equipment in addition to hutments in compliance Spatz's above paraphrase.

~~SECRET~~ SECRET

3 (SND).

0 8 3 9

26 August 1944

MAAF, USTAFF, AGWAR,  
POC, ESCOM  
Equipment

Bond

Priority

~~Top Secret~~

Amb \_\_\_\_\_  
Hq \_\_\_\_\_  
Army \_\_\_\_\_  
Supply \_\_\_\_\_  
Air \_\_\_\_\_

Tyno

~~SECRET~~ SECRET

Maker information Spaatz and Arnold and Connolly and Walsh from Mollenry signed Deane.

Ref your MX 29214, dated 26 Aug 44 on subject of fans and computers, decision contained in Arnold's cable WARK 86716, dated 26 Aug 44 obviously nullifies sending any of this equipment to Poltava. Apparently Arnold's cable crossed your MX 29214.

Walsh has all the information from this end on the 41 tons of GCI equipment and two GCI personnel now at Poltava; the two GCI personnel and possibly some GCI equipment at Tehran; and the 177 tons of GCI equipment enroute via the northern convoy.

Late information here reveals that two ships of the U.S. section of the northern convoy returned to the U.S. because of engine trouble and will join the next convoy if they were unable to rejoin the convoy now docking at Murmansk and Archangel. Information available to us indicates that the GCI equipment moving via the northern convoy is aboard one of these ships.

CLASSIFICATION CHANGED TO SECRET  
DDO, DIR 82089, 23 SEP 48

NAME \_\_\_\_\_ DATE \_\_\_\_\_

~~SECRET~~ SECRET

~~SECRET~~ SECRET

0 8 4 0



Hq USSTAF, London

German Intelligence

Hq ~~Army~~ Air ✓

JWS

Carter Office Number: 76

U-65785

2 August 1944

051640Z

021621Z

To Deane for Walsh from McDonald signed Speatz.

Enemy air activity on western front is considered in keeping with present actual strength and serviceability of units involved. Cite M-20316 July 27. Average daily single engine fighter sorties past week 345. However when weather has not curtailed operations, sorties have risen to 475 and were over 400 for four days straight. Estimate maximum possible sorties in any one day over battle area 555. Long range bomber actual strength 300. Average sortie per night 90. Mine laying off beaches principal activity with lately attacks on troop concentrations and local points behind battle front. Anti-shipping units employing HS-295 and FX-bombs operate when weather conditions permit both by day and night with average effort 10 to 15 aircraft per mission. These attacks have been ineffective and losses inflicted heavy. Torpedo aircraft attacks also curtailed by weather conditions, but operate 20 to 30 aircraft when missions possible. These have scored some successes against shipping but again losses to naval anti-aircraft and Allied night fighters have been severe. In defense of the Reich GAF can oppose 8th Air Force daylight penetrations with 100 to 120 twin-engine day fighters and 150 single engine, both day and night fighters. Against the 15th Air Force maximum effort estimated 80 twin engine and 150 single engine fighters. Against the RAF night attacks approximately 300 twin engine and 100 single engine night fighters are available and the twin engine night fighter branch of GAF considered to be at present its most effective one. Evidence of shortage of pilots in single engine fighters are seen from prisoner of war efforts and flow of replacement aircraft only sufficient to maintain strength against wastage. Loss of long range bomber force attributed to shortage both of aircraft and crews particularly strained crews. In Italy, GAF has been for all

TOP SECRET



Page 1

E

0 8 4 1

practical purposes withdrawn from active operations. Critical situation in Russia and growing threat from the west apparently dictated necessity to German High Command for withdrawal to these fronts of bulk GAF units from Mediterranean. In conclusion, Allied air superiority and overall weakness of GAF is reason for lack of effective enemy air activity which however still remains determined in spite of serious losses and admitted inferiority of Allied aircraft and anti-aircraft defense.

Second Subject: The reason for discrepancy between Anglo-American estimates and Russian photographic reconnaissance of strength of GAF on Russian front probably explained as follows: Our estimates include only planes considered operating in first line units and are thought to be accurate within 10 per cent for that classification. There are, however, a miscellaneous assortment of other planes which could certainly be photographed and may occasionally be used in combat. For example, HE-111, in addition to well identified bomb groups employing this type, there are many transport groups using the same on the Russian front. Night ground attack units--the Germans are known to employ obsolescent planes, notably Gotha-145, Arado-66, and HE-46 for night fighter bomber work. These are inadequate to daylight operations against competent defense and have principally been used against guerrillas but available in aggregate of possibly 250 aircraft. DO-217, JU-88, and FW-189, in addition to the usual Fieseler-156, are widely used for communications and light transport on the Russian front. JU-87 and HE-126 are used similarly and in addition for the towing of transport gliders. In addition to these, there are training stations and units throughout Poland and probably Rumania which would have many obsolescent planes of every type on their airfields. Finally there are well over 200 planes in the Hungarian and Rumanian Air Forces which have undoubtedly been photographed but are not part of GAF estimates. The aggregate of these miscellaneous classifications would certainly come to 1000 or 1200 planes, in addition to the 1600 to 1700 included in our estimate of GAF first line strength on the eastern front. Do not wish to disparage the value of photographic reconnaissance, obviously an extremely

~~SECRET~~

useful contributor to intelligence, but we must point out that photographic reconnaissance alone would indicate a strength of well over 1000 single engine fighters in Germany, whereas we currently estimate only about 500. The same would be substantially true of France or Northern Italy. Photographic evidence must be interpreted in the light of at least three other modifications:

- (1) The obvious possibility of duplication caused by movement of planes over a wide front.
- (2) Substantial numbers of damaged planes awaiting transport to repair.
- (3) The well-known German practice of leaving dummy aircraft around to be photographed. For the latter purpose they sometimes make very skillful use of hopelessly or slightly damaged real planes.

Third Subject: Lieutenant Colonel O'Hara has taken with him all information available you requested.

Fourth Subject: Allied landings in France achieved a distinct tactical surprise and GAF opposition to initial landings was non-existent. Germany quickly put into action apparently prearranged plan to move Luftwaffe forces to western front, especially single engine fighters. Within a week 425 single engine fighters reinforced west. This represented 14 Gruppen all of which with the exception of 1 Gruppe were withdrawn from Germany and Austria. During early stages attempts made to use single engine fighters as fighter bombers against ground targets but this policy quickly abandoned due to extremely high wastage incurred. Principal feature of twin engine fighter operations was use of JU-88 day fighters as ground attack aircraft. This resulted in total failure and severe losses. Units quickly withdrawn and returned to normal offensive reconnaissance duties over Bay of Biscay, since which one such unit has been moved to the Russian front. The single engine fighter bombers drawn from Italy suffered extremely heavy losses and soon forced to abandon task. These units also have since moved to Russian front. Long range bombers which had been steadily reinforced for some weeks prior to launching of overlord totaled about 400 aircraft in the west on D-Day, plus an additional 90 torpedo

~~SECRET~~

bombers in southeastern France and northern Italy, which immediately operated against shipping in the channel. Operations by anti-shipping units equipped with HE-177 and DO-217 and especially strengthened and trained during winter months to oppose our landings with glide bomb and radio controlled bombs failed dismally to put up anticipated scale of effort. Such attacks as were attempted resulted in severe losses and practically no successes were attained with little or no damage to Allied shipping and no interruption whatsoever caused in the flow of supplies across the channel. Normal long range bomber units based in northern France, after some initial efforts at bombing of shipping without success during which they incurred heavy losses, changed over to sea mining almost immediately recognizing this method was only possible means of achieving any success against Allied shipping in view of Allied air superiority and anti-aircraft defenses. In opposition to OVERLOAD the GAF has proven to be the most negligible factor involved due first to the results obtained from our attacks on aircraft production centers under POINTBLANK, resulting in an overall weakness in the GAF, to overwhelming Allied air superiority, to the disorganization in German airfield and supply organizations in France as a result of Allied bombing of these targets and anti-air force operations previous to D-Day and to the tactical surprise achieved by the Allied landing.

25 Aug 1944  
ACMAR, Washington  
Hq MAAF, Caserta  
FRANTIC Expansion

Amb \_\_\_\_\_  
Hq \_\_\_\_\_  
Army \_\_\_\_\_  
Sup \_\_\_\_\_  
Air

MX 20708

Deane

Carter

Priority

~~SECRET~~ SECRET

~~SECRET~~ SECRET

For GENERAL ARNOLD and repeated to BAKER FOR GENERAL SPAATE at Caserta  
from DEANE TOPREC

Reference your WAXX <sup>85979</sup> ~~85979~~ of 25 August please see my number MX-2701 <sup>20701</sup>  
of same date. With regard to directing night fighter squadron elsewhere  
and curtailing flow of supplies, I presume General Spaate will give you  
definite recommendation, but if not, I will submit recommendations as  
soon as I have talked to General Nikitin.

~~SECRET~~ SECRET

CLASSIFICATION CHANGED TO SECRET  
DDO 2ND 5400.8, 27 SEP 48

DATE

DATE

1 (END) E

0 8 4 5

INCOMING MESSAGE  
U S MILMIS, MOSCOW

**PARAPHRASE**

|              |                          |          |               |
|--------------|--------------------------|----------|---------------|
| From         | : AGWAR, Washington      | Number   | : WAR X47831  |
| Subject      | : Technical Info to USSR | Date     | : 8 June 1944 |
| Distribution | : Duplicate              | Received | : 06090955Z   |
| Decoded      | : DMW                    | Security | : TOP SECRET  |
|              |                          | Typed    | : Flavin      |

~~TOP SECRET~~

From the Joint Chiefs of Staff to Deane, repeated to Devers and Eisenhower.

1. The Combined Intelligence Committee has been directed by The Combined Chiefs of Staff to provide lists of technical information recommended for release to the USSR.

2. Pending completion of these lists, top secret, secret, and confidential items not previously approved for disclosure to the USSR will not be approved for disclosure to the USSR without reference to the Combined Sub Committee on Disclosure of Technical Information, or the Combined Intelligence Committee.

3. Regarding the disclosure of technical information to the USSR, the policy of the Joint Chiefs of Staff is as follows:

a. Technical information which may be released--information falling within the categories listed below may be furnished the USSR:

(1) Technical information pertaining to the improvement and maintenance of weapons, devices and equipment which are in use already by the USSR.

(2) Technical information concerning equipment, devices and weapons, manufacturing processes or designs intended for use by or from the USSR which are in production, field test or are standard authorized equipment.

(3) Technical information which is unclassified, or carrying a classification equivalent to US "restricted".

b. Technical information which may not be released--The USSR will not be furnished with technical information regarding items of equipment.

CLASSIFICATION CHANGED TO SECRET  
DDO DIR 5200.9, 27 SEP 55  
*[Signature]*  
NAME DATE

~~TOP SECRET~~

**PARAPHRASE**

0 8 4 6



~~SECRET~~

# PARAPHRASE

weapons, projects, devices, processes, or designs which fall in the following categories:

- (1) Items and processes, the disclosure of which may be specifically restricted by an established agency of either the Joint Chiefs of Staff or the Combined Chiefs of Staff.
- (2) Items in fields of scientific research which have not yet reached the stage at which their applicability to specific military or naval uses can yet be reasonably determined.
- (3) Items in the developmental, experimental, or laboratory stage.

4. In order to avoid misunderstanding of intent, the following interpretation of paragraph 3 a (2), above:

"Technical information may be furnished the USSR concerning devices, weapons, equipment, manufacturing processes or designs, which are in production, field test, or are standard authorized equipment, and which can be employed advantageously by the USSR in the prosecution of the war against Germany, with the following provisos:

- a. That strategic surprise in the employment of any item will not be jeopardized;
- b. That the information or equipment is appropriate to the general types of operation to be undertaken by Red Forces;
- c. That the information can be put to use by the USSR within the time limitations believed to exist;
- d. That the effectiveness of important US operations will not be jeopardized.

The USSR may be furnished with information concerning equipment, devices and weapons which are used by Allied forces operating from areas under USSR control.

(Except wherein contrary to paragraph 3 b (1), above.)

Page 2.

(END)

# PARAPHRASE

~~SECRET~~

7 7 5 0  
0 8 4 7  
1 2 5 2



*File*

Spaatz, London

Expansion Operations Russian Bases

Triplicate

DMW

13230

5 June 44

0806725Z

Flavin

P R I O R I T Y

To Deane information to Arnold from Spaatz.

Viewing expansion our operations from Russian bases am taking steps increase supplies effective 1 September to provide for 1600 heavy bomber sorties monthly thereafter. Fighter sorties contemplated roughly 900 monthly. Above indicated increase not dependent outcome of following, but believe time at hand when talks should commence on permanently basing United States air units near Russian Western Front. Size of force initially to be three heavy bombardment groups and one fighter group. Airplanes will be B-17's and P-51's. Initial planning assumes these units will be based on the three fields now occupied by EASTCOM plus one additional field or on four new more advanced fields. Contemplated base organization is along lines of old air base set up formerly used in States. One group at each field, with such service units as are necessary. The overall personnel figures will be forwarded later, for airplanes are bombers 144 with 36 in reserve, for fighters 75 with 20 in reserve. Anticipate above force can be made available for entry into Russia during September this year. Please send copy this message to Walsh by your next courier. Request your comments on the above bearing in mind that we have a force of air division magnitude in mind for eventual placement in Russia should need for such action arise. Request also you endeavor to obtain official Russian attitude toward above proposal. Particular study of Russian supply carrying capacity which can be made available is indicated. Aviation fuel appears so far to be greatest supply problem.

(END)

0 8 4 8

*Col. K... ..*

JCS  
 PRANTIC Publicity  
 Triplicate

Book Mag  
 3 June 44  
 06030800Z

MAB

~~TOP SECRET~~  
 Feldstein

~~TOP SECRET~~

To EISENHOWER and DEANE from the JOINT CHIEFS OF STAFF

When the joint Chiefs of Staff approved the instructions to Spaatz and Deane contained in their message of 31 March 1944 (WARK 16975) respecting publicity for PRANTIC, it was intended that unless major issues were involved, necessary coordination should be achieved directly between the concerned agencies in U.K. and USSR without further combined or Joint Chiefs of Staff approval. In line with this policy we are referring Eisenhower's dispatch, number S-52394, to Deane for his information with suggestion that the following be added under propoganda themes "Need of Germany to regroup her already strained air defense system spread thin by air attacks from bases in Great Britain and Italy. The operation again proves that agreements reached at Teheran are being fully implemented by United Nations."

Suggest that agreed propoganda theme as finally coordinated by Deane be transmitted to London and Washington for information.

~~TOP SECRET~~  
 RECEIVED BY THE ARMY  
 30 1 R 30

CLASSIFICATION CHANGED TO SECRET  
 (SIC) (SIC) (SIC) (SIC) (SIC) (SIC)

NAME DATE

15

~~TOP SECRET~~

7  
 0 8 4 9  
 1 2 3 4 5 6

EQ MAAF

FRANTIC Publicity

Triplicate

VIA BRITISH CHANNELS

M 19116

2 June 1944

021340B

~~SECRET~~ SECRET

Carter

~~SECRET~~ SECRET

From Baker 30 Mission to DEANE

No acknowledgement received of receipt of my M-19034 regarding  
GWT of press release.

~~SECRET~~

CLASSIFICATION CHANGED TO SECRET  
DDI DIR 820943, 22 MAR 58  
*[Signature]*  
NAME DATE

10

~~SECRET~~ SECRET

7 4 7  
0 8 5 0

Militia, Embassy, London

13170

FRANTIC operations

1 June 1944

Triplicate

06020750Z

MAD

~~SECRET~~  
Carter~~SECRET~~URGENT

Action DEAME info to ARNOLD, EAKER, AND KESSELER as SPAATZ U62986

Position re initial FRANTIC operation to you to make known to Russians if you deem advantageous is: We are operating into East, June 2 if weather does not deteriorate, hitting Braeov and/or other transportation along line you indicated on way. Unless other targets suitable for attack by gasing at Poltava are cleared in meantime, Air Commander might decide return to home bases soon as possible taking another target along specified line on way home. This decision rests with Air Commander. We feel operating from and returning to Poltava against specified line of targets not feasible since more efficient we take them from Italian bases. Letter will be done by 15th Air Force often as overall situation permits in any case.

~~SECRET~~  
PEABODYCLASSIFICATION CHANGED TO SECRET  
EOG DR 2200A, 22 SEP 58

NAME

DATE

(7)

~~SECRET~~

0851

CE Kessen  
HQ MAAF, Caserta  
FRANTIC Operations  
Triplicate

BT751  
1 June 1944  
011842B  
~~SECRET~~  
Carter

VIA BRITISH CHANNELS

~~SECRET~~

30 MISSION for DEANE from RAKER

As at 1600 hours GMT, initial FRANTIC operation continues to be scheduled for 2 June repeat 2 June. There is no change in details previously forwarded to you.

~~SECRET~~

CLASSIFICATION CHANGED TO UNCLASSIFIED  
DOD DIR 8200.6, 21 SEP 98

DATE 01/11/98 BY 3411/07

(5)

~~SECRET~~

0 8 5 2

HQ, MAAP

FRANTIC Operations

Triplicate

VIA BRITISH CHANNELS

M-19049

1 June 1944

011715/31

~~TOP SECRET~~

Carter

~~TOP SECRET~~

30 MISSION, Moscow, for DEANE from KAKER

Route, altitudes, and time remain as indicated in our D4IE and D5IE 31 May. After crossing (?) Dnieper River bombers will descend to 6,000 feet and fighters to 7,000 feet as indicated in cited message or repeat or below the clouds if overcast conditions prevail. Please confirm that Soviet coordination is complete for operation on 2 June repeat 2 June.

~~TOP SECRET~~  
1

CLASSIFICATION CHANGED TO UNCLASSIFIED  
DOD DIR 8200.22 22 SEP 82

NAME DATE

(4)

~~TOP SECRET~~

0 8 5 3

HQ HQAF

FRANTIC Publicity

Triplicate

VIA BRITISH CHANNELS

*Handwritten:*  
Lester  
C. R. Kessler

M19034

1 June 1944

011615/1

~~SECRET~~

Carter

~~SECRET~~

30 MESSAGE pass to GENERAL DEANE, Moscow, from EAKER

It is most important that you let me know here, as soon as known to you, the time and date of press release on the operation in order that a short general release may be made by AFHQ subsequent to Moscow release. Please advise the time on GMT. Acknowledge. This message is TOP SECRET.

~~TOP SECRET~~  
R 30

RECEIVED  
BY THE  
R 30

(3)

~~SECRET~~

0 8 5 4



Milletsche, Embassy, London

13169

FRANTIC Personnel

1 June 1944

Triplicate

00000000

~~SECRET~~

MAB

Carter

~~SECRET~~

Information DEANE action KESSLER information ARNOLD and CONNELLY  
as SPAATZ UL2980

About 40 radio maintenance enlisted men assembled by Maintenance Division, this headquarters, and similar number assembled by Signal Section and both groups shipped is shown by recheck of personnel records. Request outstanding men this category from both groups be retained and those not needed for essential functions be returned here. Report to this headquarters and Persian Gulf Command necessary personnel data. Shipment to you of additional personnel requested and still remain within 1250 limit will thereby be permitted. Request your views on this and also on following: Complete personnel survey desired to be conducted from same viewpoint as above and submit by radio your desires pertinent to replacements plus necessary personnel information on each person and recommendation as to how their rotation may be effected. Personnel overages certain categories, serious illness, incompetence, or need for personnel with other qualifications higher in priority than persons available are only reasons to be used for rotation recommendations. All addressees particularly Deane cite 181 please note 30 P-51 fighter mechanics coming with operational bombers from Italy and will stay as part of permanent staff at East Command. Passage through Teheran of this personnel not contemplated.

FRABODY

CLASSIFICATION CHANGED TO  
TOP SECRET, 12 MAR 88  
DATE 3/21/88  
NAME [Signature] DATE [Signature] ~~SECRET~~

R 30  
Page 1 (END)

0 8 5 5

HQ MAAF, Caserta

Colors and letters of the day

Triplicate

British Air Ministry

RS-559 D-5 IE

1 June 1944

06/01/1120B

~~TOP~~ SECRET

White

~~TOP~~ SECRET

EMERGENCY

Thirty Mission for DEANE from HQ MAAF Special Signals Office signed  
BAKER RS-559 D-5 IE TOP SECRET JUNE 1.

Russian colors and letters of the day for initial operation have  
been urgently requested from Kessler but no reply yet received. Can  
you expedite this information via Thirty Mission Signals.

NO SIG.

~~TOP SECRET~~

CLASSIFICATION CHANGED TO SECRET  
600 DIR 8200A, 27 SEP 88  
*[Signature]*  
NAME DATE

~~TOP~~ SECRET

0 8 5 6

*File*  
8 June 1944

Milattache, Amembassy, London  
AGWAR, Washington

FRANTIC Operations

Deane

Carter

URGENT

~~TOP SECRET~~

~~TOP SECRET~~

For General Spantz repeated to General Arnold for information from Deane TOPSEC

Early this morning received request from General Eaker who is at Poltava to obtain Russian clearance for an attack against Constanza on return to home bases in Italy. He indicates photo-reconnaissance has established a large concentration of transports in the port. Red General Staff has promised to send reply to General Perminov at Poltava this afternoon, and if reply is favorable they will indicate the best available route to follow.

I told the Soviets that General Eaker wished to have Buzal as an alternate target for today through Tirasopol. However I did not receive your number 13246 dated the seventh until eleven a.m. Moscow time on the eighth. I therefore requested that this be designated as an alternate target for Constanza for either the ninth or the tenth..

My communications with Poltava are almost impossible and will be until Saturday, June 10, when I expect to open operations between the station now being installed in Moscow direct with Poltava. Once these are in, I will be able to coordinate very quickly. Between now and Saturday, the fastest way to communicate with me is to have General

CLASSIFICATION CHANGED TO SECRET  
DOD DIR 92206, 27 SEP 54

~~TOP SECRET~~

Page 1

NAME

DATE

(M139)

BY THE PAR 95 R 30

0857

SECRET

~~SECRET~~

Perninov send the message from Poltava over Soviet channels, but even  
this is slow and unsatisfactory. Request that this message be repeated  
to ESCOM.

~~SECRET~~

(M139)

Page 2 (END)

0 8 5 8

*File*

3 June 1944

MILATTACHE, Amembassy, London  
AGWAR, Washington  
FRANTIC publicity

Deane White

Routine

~~SECRET~~ SECRETTo General EISENHOWER repeated to JOINT CHIEFS OF STAFF, TOPSEC.  
from DEANE

Following is with reference to WAR 45116 and book message both received from the Joint Chiefs of Staff dated 3 June 1944.

Publicity in connection with FRANTIC was difficult to coordinate. As you know I had prepared a plan a long while ago but was never able to get full Russian collaboration. The reason was that the General Staff would not touch the subject nor would they allow me to approach the press people for security reasons. As a result I had to handle it the best I could but it has not been satisfactory in all respects. I handled the British and American correspondents somewhat independent of the Soviet correspondents, although I made every effort to include the Soviets. I emphasized to our correspondents that we should give: (1) Full credit to the Russians. (2) The harmony existing between Soviet and American personnel. (3) Give credit to high-ranking Soviet Officers. (4) Only authorized use of Kessler's name as the American in charge. (5) The additional burden that was put on the Soviet war machine. (6) The effects of shuttle bombing such as opening up new target areas, causing redistribution of German fighter defense, assistance to Russian advances,

CLASSIFICATION CHANGED TO SECRET  
BY SP-6 JRS/STP/STP  
DATE 27 SEP 88  
NAME John Thomas 3/11/52  
MAIL

(M138)

Page 1

JUN 23 1944

0859

morale effect, and pattern of future Russian-American cooperation.  
(7) Emphasize the part the British played on the western end of the shuttle bombing to indicate that this was a combined operation even though the Americans were carrying out the operations.

I prohibited our people from mentioning the location or number of operational bases, the number of aircraft, the methods of operation, the number of personnel, any description that would identify the location of the bases, any comments on Russian defenses of the bases.

I concur with the propaganda program indicated in War Department message 48116. I think that you will find that much of it has already been carried out in the stories which have been allowed to go out. I shall take up the matter of the leaflets, but it takes the Russians a long time to come to a decision on matters of this sort. Meanwhile, I think you are perfectly safe in carrying out the propaganda program outlined and recommend that you do so.

(M138)

Page 2 (END)

0 8 6 0

Col. Kercher

2 June 1944  
HQMAAF, Caserta  
MILATTACHE, Embassy, London  
ATTNAR, Washington  
Press Release - PRANTIC

White

URGENT

~~TOP SECRET~~

To WAKER, SPAATE, and ARNOLD signed DEANE. ~~TOP SECRET~~

Initial PRANTIC press release authorized in Moscow at fourteen  
M-1911L  
zero zero george mike tare time two june pd Answers M-1911L and M-19034 pd

CLASSIFICATION CHANGED TO SECRET  
DDO DIR, SECDEF, 27 SEP 58

*E. Thomas* 3 Mar 59  
NAME DATE

Page 1 (END)

(M136)

0861



~~TOP SECRET~~ SECRET

5 June 1944

AOMAR, Washington

FRANTIC Operations

Deane Carter

URGENT

~~TOP SECRET~~ SECRET

For General Arnold's eyes only from DEANE ~~TOP SECRET~~

First FRANTIC operation considered by all a huge success. General Baker appeared to be well pleased with the arrangements at the bases.

Present plan is Mielec on June 5 and airdromes in the Gelatz area on June 6 en route to Italian bases.

Delighted that Walsh has arrived and he has already started taking over. He is at Poltava at the time and will remain there until first mission is completed.

I will get to work at once with Mr. Harriman on carrying out the views you expressed to him when he was in Washington.

CLASSIFICATION CONTAINED IN SECRET  
THIS COPY SHOULD BE KEPT IN  
NAME *James 3/10/20* DATE

~~TOP SECRET~~ SECRET  
(M135) ④

0 8 6 2

*Robert  
C. Kessler*

2 June 1944  
ER MAAP  
Milatzeche, Amembassy, London  
AGWAR, Washington  
FRANTIC Publicity

Crist Carter

URGENT

~~SECRET~~ SECRET

~~SECRET~~ SECRET

To BAKER, SPAATZ, and ARNOLD from CRIST signed DEANE TOPSEC

Correspondents given hold for release statement on initial operation.  
Release planned immediately upon landing between 1030 and 1200 hours today  
GMT, but stories now with Soviet censors and no repeat no indication  
when Soviet approval forthcoming. Pressing for action and will advise  
immediately when and for what time release cleared by Soviets.

~~SECRET~~ SECRET

(M134)

(3)

*3/16/50*

Page 1 (END)

0863

1 June 1944

CG PGC Teheran

Teheran-Poltava couriers

Crist Jacques

Routine

~~TOP SECRET~~ SECRET

To Connolly from Deane TOPSEC.

Have received information from Soviet Foreign Office that American couriers will be permitted to operate courier service from Teheran to Poltava. The American Embassy in Teheran is being instructed to get in touch with the Soviet Embassy this for instructions covering documentations to be furnished the couriers, and also methods required for making up the pouches for forwarding cryptographic materials.

It is requested that prior to use of this method that I be informed of all details which the American Embassy receives from the Soviet Embassy in Teheran. Upon receipt of favorable information I will advise the Signal Security Agency to furnish you the package numbers so that your headquarters may intercept the cryptographic documents destined for these bases and reship by means of this authorized courier service instead of routing them through Moscow.

~~TOP SECRET~~  
R 30  
(M133) *Deane 3/10/55*

0 8 6 4

~~SECRET~~ *air*

17 August 1944

USSTAF, London  
ESCOM, Poltava  
Russian Reconnaissance Summary

de Sakhnoffsky Typist: Miller

Routine

~~SECRET~~ Secret*Mx 2-066**RE*To Spaatz for Macdonald from McHenry signed Deane info Walsh ~~SECRET~~

Russian Reconnaissance Summary of 15 August 1944.

Northwest Sector: In spite of unfavorable meteorological conditions, enemy aircraft in groups of 14 to 18 JU-87s escorted by fighters, and in groups of 10 FW-190s operated against our units on the front lines and immediate rear. Fighters in groups of 8 aircraft acted as ground unit cover.

Aerial reconnaissance registered: Vyartailya - 12 fighters.

Central Sector: Enemy fighters in groups of 4 aircraft acted as cover for the ground troops and immediate rear.

Aerial reconnaissance registered: Insterburg - 80 aircraft.

Kemokshy - 12 aircraft. Letsen - 48 aircraft. On the airdrome 5 km south of Ciechanov - 35 aircraft. Lykk - 17 aircraft. Aris - 5 aircraft. Mostken - 12 aircraft. Gr. Shimanen - 15 aircraft. Bayaldovo - 40 aircraft. Rastenburg - 25 aircraft. Ortelsburg - 18 aircraft. Flotak - 40 bombers. Modlin - 25 aircraft. Krotchevo - 16 fighters. Naselsk - 10 bombers and 20 fighters. Sokhatchev - 75 aircraft, of which 58 fighters. Vvarshawa (Central) - 18 FW-190. Vvarshawa (South) - 3 JU-52. Jrupets - 40 aircraft. Melinsk - 25 aircraft. Pyastov - 15 aircraft. Radom - 70 aircraft.

Southern Sector: Khushki - 45 aircraft. Kishinev - 18 aircraft. Leipzig - 10 aircraft.

~~SECRET~~CLASSIFICATION CHANGED TO SECRET  
DO NOT DISSEMINATE EXCEPT AS AUTHORIZED*Shimanen 240159**M122*

0 8 6 5

~~SECRET~~ SECRET

Buzau - 51 aircraft, of which 25 fighters. Yanka - 6 aircraft. Galati - 23 aircraft.

Recco summary for 12 August 1944.

Northmost Sector: On the 12th of August enemy bombers in groups of 13 Ju-87s attacked our troops along the front lines. Fighter aircraft in groups of 10 FW-190 kept up an intensive offensive.

Central Sector: Recco showed: Instertburg (South) - 100 aircraft, mainly single engine. Bucharest - 10 aircraft. Gerdauen - 52 aircraft, of which 21 Ju-87. Torn - 120 aircraft. Lodz - 35 aircraft. Ortelburg - 45 aircraft.

Southern Sector: Recco showed: Galnye - 1 aircraft, Mushi - 15 aircraft, mostly fighters.

M122

~~SECRET~~ SECRET

CLASSIFICATION CHANGED TO SECRET  
BY *Thomas* *M. H. B.*  
NAME DATE

2 (end)

0 8 6 6

14 August 1944 DISTRIBUTION: Amb \_\_\_\_\_  
Hq \_\_\_\_\_  
HQ USSTAF, London Air \_\_\_\_\_  
Convoy deadline Army \_\_\_\_\_  
Supply \_\_\_\_\_  
Walsh TYPIST: White

PRIORITY

~~SECRET~~

~~SECRET~~ SECRET

To SPAATZ from WALSH signed DRANT. TOPSEC.  
Reference UX-65968.

Soviet authorities have not repeat not replied to formal letter  
and information verbally given them that August 14 was deadline date  
for loading on next convoy for PRANTIC expansion.

M1108

~~SECRET~~ SECRET

1 (END)

0867

~~TOP SECRET~~ SECRET

## DISTRIBUTION:

 Amb \_\_\_\_\_  
 Hq \_\_\_\_\_  
 Army \_\_\_\_\_  
 Supply \_\_\_\_\_  
 Air \_\_\_\_\_

11 August 1944

 USSTAF, London  
~~XXXXXXXXXXXXXXXXXXXX~~  
 Easoon, Poltava  
 Russian Recco Summary

de Galchenoffsky

Typist: Miller

Routine

~~TOP SECRET~~

M 20591

To Spaatz for Macdonald info Walsh signed Deane TOPSECRET

Russian recco summary for 11 August 1944.

Northwest Sector. On August 11 groups up to 12 Bf-109 attacked troops on the front lines. Recco showed: Solvassero - 25 aircraft. Tishkosero - 3 aircraft. Ioasca - 23 aircraft. Vyartasylya - 18 aircraft. Rystilakhti - 25 aircraft. Amphibious base at Tallin - 10 aircraft. Tartu - 26 aircraft.

Central Sector. In the 11th groups of 8 to 25 aircraft escorted by fighters attacked troops. Fighters in groups up to 15 protected enemy troops, railroad centers, etc. Recco showed: Instertburg - 50 aircraft. Restenburg - 52 aircraft. Letson - 15 fighters. Lomja - 10 aircraft. Lytk - 4 aircraft. Pzayanyas - 35 bombers. Osiekhanov - 64 aircraft, of which 59 bombers. Makov - 5 fighters. Krotebevo - 52 aircraft, of which 32 Bf-11 and 20 fighters. Modlin - 20 fighters. Krakow - 180 aircraft, second recco - 150 aircraft.

Southern Sector. Roman - 5 aircraft. Bakau - 50 aircraft, of which 32 fighters. Fokshani - (on two airdromes) - 70 aircraft. Khushi (two airdromes) - 60 aircraft. Kishinev - 30 aircraft. Komrat - 20 aircraft. Byrlad - 5 aircraft. Tokhouchi - 20 aircraft. Leiptsig - 15 aircraft. Matka - 12 Bf-110. Myndroshti - 2 aircraft. Sikkhaya - 20 aircraft. Rymnikul - Serat - 2 aircraft. Boboka - 30 aircraft, of which 49 fighters.

 NAME Thomas J. Walsh  
 GRADE MAJ

105

~~TOP SECRET~~ SECRET

1 R-30

0868



14 Aug 1944

HQ USSTAF, London

FRANTIC Mission

Walsh

URGENT

~~TOP SECRET~~

Amb 1  
Air 2  
Hdqs 1  
Army

White

~~TOP SECRET~~

To SPARTZ from WALSH signed DEANE. ~~TOP SECRET~~

Have requested immediate appointment with Red Air Staff and ESCOM through Perminov will coordinate operational features. For your information approval this mission may be involved because of requests by British on highest level for Russians to accomplish a similar mission and also possible recent political considerations may be involved in securing Soviet approval. Harriman and I exerting strongest pressure for clearance here. Request immediate advice on any change in plans.

(M 103 - M 105 - SEE M 70)

M 102

~~TOP SECRET~~

REVISION CHANGED TO SECRET (TOP)  
DATE 27 SEP 48  
*Thomas Snows*

0869

Casablanca

W-857

B-17 in Teheran

14 August 1944

Amb \_\_\_ Air  Army \_\_\_ Hq \_\_\_ Army \_\_\_

14/0930Z

RC

13/1750Z

Zinkand

Office No. 219

~~SECRET~~ SECRET

~~SECRET~~ SECRET

TO: Deane from KRISTOFFERSON signed STOWELL:

Unable according to Teheran are United Kingdom special cargo B-17s to get clearance to go to Russia. These B-17s are now in Teheran. Since B-17s have often flown route it is difficult to understand the reason for this inability to get clearance. Because of existant backlogs in this area these planes are needed and as soon as mission is finished must return to United Kingdom by way of Teheran base.

Action: Air Div.

R 30

*Thomas Stowell*

0 8 7 0

~~SECRET~~

10 Aug 44  
 USSTAF, London  
 German Order of Battle

Amb \_\_\_\_\_  
 Hq \_\_\_\_\_  
 Army \_\_\_\_\_  
 Supply \_\_\_\_\_  
 Air \_\_\_\_\_

20530

de Sakhnoffsky

Miller

Routine

~~SECRET~~

To SPAATZ for MACDONALD signed DEASE

Follows Russian information on German Air order of battle as of

2 August 1944:

Northwest Sector:

Rakvere - 1st and 2nd Gruppe 54th Fighter Geschwader.

Central Sector:

Koenigsberg - 1st, 5th and 6th Gruppe 100th Night Fighter Geschwader,  
4th and 5th Staffeln, 1st twin engined Fighter Geschwader.

Suwalki - 1st Gruppe 51st Fighter Geschwader.

Lopsha - 3rd Staffel 100th Night Fighter Geschwader.

Southwest Sector:

Plotsk - 4th and 12th Staffeln 100 Night Fighter Geschwader.

Krakow - 10th Staffel 2nd Night Fighter Geschwader.

Undetermined location - 3rd Gruppe 51st Fighter Geschwader and  
6th Staffel 1st twin engined Fighter Geschwader.

Southern Sector:

Kishinev - 1st Gruppe 52nd Fighter Geschwader.

Gialats - 2nd Gruppe 52nd Fighter Geschwader.

Isaail - 3rd Gruppe 52nd Fighter Geschwader.

CLASSIFICATION CHANGED TO SECRET  
 ON 04 APR 82 BY SP5  
 [Signature] DATE

~~SECRET~~

M 84

0871

HQ USSTAF, London

Personnel &amp; Convoys

Amb \_\_\_ Air  Hqs \_\_\_ Army \_\_\_

EIS

Zinkand

Office No. 147

UX-66030

9 August 1944

09/1245E

07/1046Z

MEMOR for KNEER Information WALSH signed SPAATZ, UX-66030, reference GURAD U-35997 which was paraphrase of war I-79533 and Reourad U-35968 reported to MAAP as M-51738.

Being sent to you for your information is following:

- (a) Alert orders changed directing all units take complete TE and OEL.
- (b) Approximately 4000 personnel scheduled leave by southern convoy to 24 August. Deadline for cancellation 15 August.
- (c) TE and OEL plus 90 day maintenance supply level to be shipped from UK on northern convoy leaving 13 September. Deadline for cancellation 15 August.
- (d) Cancellation of either or both convoys will cause minimum delay of 30 days depending on availability of shipping and congestion. Terminal port facilities.
- (e) Units being shipped from this theater not affected by above but probably will be likewise delayed if Soviet approval not given promptly.
- (f) Engineer BN Equipment being loaded now and cannot be stopped.
- (g) Engineer personnel going on 24 August convoy and can be stopped with other personnel.
- (h) Survey being made on availability 90 days supply level in UK but do not believe full level here. However confident sufficient supplies available to implement expansion.
- (i) Supply of winter housing for personnel now at Russian bases now enroute from United States. Remainder must come from United States and will take 3 to 4 months after Soviet approval.
- (j) Another problem is entry of personnel and material into our bases during winter if lack of Soviet approval delays our program.

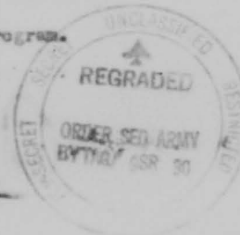

0 8 7 2

*To East ...*

|                          |                       |
|--------------------------|-----------------------|
| Hq USSTAF, London        | U-65785               |
| German Intelligence      | 2 August 1944         |
| Hq Army Air              | 051640Z               |
| JWS                      | 021621Z               |
| Carter Office Number: 76 | <del>XXXXXXXXXX</del> |

*WHL*

To Deane for Walsh from McDonald signed Speats.

Enemy air activity on western front is considered in keeping with present actual strength and serviceability of units involved. Cite M-20316 July 27. Average daily single engine fighter sorties past week 345. However when weather has not curtailed operations, sorties have risen to 475 and were over 400 for four days straight. Estimate maximum possible sorties in any one day over battle area 550. Long range bomber actual strength 300. Average sortie per night 90. Mine laying off beaches principal activity with lately attacks on troop concentrations and local points behind battle front. Anti-shipping units employing HS-293 and FX-bombs operate when weather conditions permit both by day and night with average effort 10 to 15 aircraft per mission. These attacks have been ineffective and losses inflicted heavy. Torpedo aircraft attacks also curtailed by weather conditions, but operate 20 to 30 aircraft when missions possible. These have scored some successes against shipping but again losses to naval anti-aircraft and Allied night fighters have been severe. In defense of the Reich GAF can oppose 8th Air Force daylight penetrations with 100 to 120 twin-engine day fighters and 150 single engine, both day and night fighters. Against the 15th Air Force maximum effort estimated 80 twin engine and 150 single engine fighters. Against the RAF night attacks approximately 300 twin engine and 100 single engine night fighters are available and the twin engine night fighter branch of GAF considered to be at present its most effective one. Evidence of shortage of pilots in single engine fighters are seen from prisoner of war efforts and flow of replacement aircraft only sufficient to maintain strength against wastage. Loss of long range bomber force attributed to shortage both of aircraft and crews particularly strained crews. In Italy, GAF has been for all

REGRADED

Page 1

ORDER SEC ARMY

0 8 7 3

practical purposes withdrawn from active operations. Critical situation in Russia and growing threat from the west apparently dictated necessity to German High Command for withdrawal to these fronts of bulk GAF units from Mediterranean. In conclusion, Allied air superiority and overall weakness of GAF is reason for lack of effective enemy air activity which however still remains determined in spite of serious losses and admitted inferiority of Allied aircraft and anti-aircraft defenses.

Second Subject: The reason for discrepancy between Anglo-American estimates and Russian photographic reconnaissance of strength of GAF on Russian front probably explained as follows: Our estimates include only planes considered operating in first line units and are thought to be accurate within 10 per cent for that classification. There are, however, a miscellaneous assortment of other planes which could certainly be photographed and may occasionally be used in combat. For example, HE-111, in addition to well identified bomb groups employing this type, there are many transport groups using the same on the Russian front. Night ground attack units-- the Germans are known to employ obsolescent planes, notably Gotha-145, Arado-66, and HE-46 for night fighter bomber work. These are inadequate to daylight operations against competent defense and have principally been used against guerrillas but available in aggregate of possibly 250 aircraft. DO-217, JU-88, and FW-189, in addition to the usual Fiesler-156, are widely used for communications and light transport on the Russian front. JU-87 and HE-126 are used similarly and in addition for the towing of transport gliders. In addition to these, there are training stations and units throughout Poland and probably Rumania which would have many obsolescent planes of every type on their airfields. Finally there are well over 200 planes in the Hungarian and Rumanian Air Forces which have undoubtedly been photographed but are not part of GAF estimates. The aggregate of these miscellaneous classifications would certainly come to 1000 or 1200 planes, in addition to the 1600 to 1700 included in our estimate of GAF first line strength on the eastern front. Do not wish to disparage the value of photographic reconnaissance, obviously an extremely



~~TOP SECRET~~

useful contributor to intelligence, but we must point out that photographic reconnaissance alone would indicate a strength of well over 1000 single engine fighters in Germany, whereas we currently estimate only about 500. The same would be substantially true of France or Northern Italy. Photographic evidence must be interpreted in the light of at least three other modifications:

- (1) The obvious possibility of duplication caused by movement of planes over a wide front.
- (2) Substantial numbers of damaged planes awaiting transport to repair.
- (3) The well-known German practice of leaving dummy aircraft around to be photographed. For the latter purpose they sometimes make very skillful use of hopelessly or alightly damaged realy planes.

Third Subject: Lieutenant Colonel O'Mara has taken with him all information available you requested.

Fourth Subject: Allied landings in France achieved a distinct tactical surprise and GAF opposition to initial landings was non-existent. Germany quickly put into Serion apparently prearranged plan to move Luftwaffe forces to western front, especially single engine fighters. Within a week 425 single engine fighters reinforced west. This represented 14 Gruppen all of which with the exception of 1 Gruppe were withdrawn from Germany and Austria. During early stages attempts made to use single engine fighters as fighter bombers against ground targets but this policy quickly abandoned due to extremely high wastage incurred. Principal feature of twin engine fighter operations was use of JU-88 day fighters as ground attack aircraft. This resulted in total failure and severe losses. Units quickly withdrawn and returned to normal offensive reconnaissance duties over Bay of Biscay, since which one such unit has been moved to the Russian front. The single engine fighter bombers drawn from Italy suffered extremely heavy losses and soon forced to abandon task. These units also have since moved to Russian front. Long range bombers which had been steadily reinforced for some weeks prior to launching of overlord totaled about 400 aircraft in the west on D-Day, plus an additional 90 torpedo



bombers in southeastern France and northern Italy, which immediately operated against shipping in the channel. Operations by anti-shipping units equipped with HE-177 and D9-217 and especially strengthened and trained during winter months to oppose our landings with glide bomb and radio controlled bombs failed dismally to put up anticipated scale of effort. Such attacks as were attempted resulted in severe losses and practically no successes were attained with little or no damage to Allied shipping and no interruption whatsoever caused in the flow of supplies across the channel. Normal long range bomber units based in northern France, after some initial efforts at bombing of shipping without success during which they incurred heavy losses, changed over to sea mining almost immediately recognizing this method was only possible means of achieving any success against Allied shipping in view of Allied air superiority and anti-aircraft defenses. In opposition to OVERLOED the GAF has proven to be the most negligible factor involved due first to the results obtained from our attacks on aircraft production centers under POINTBLANK, resulting in an overall weakness in the GAF, to overwhelming Allied air superiority, to the disorganization in German airfield and supply organizations in France as a result of Allied bombing of these targets and anti-air force operations previous to D-Day and to the tactical surprise achieved by the Allied landing.

M-76

0876

29 July 1944

USSTAF, London

Russian Intelligence Information

de Sakhnoffsky TYPIST: White

Priority

~~SECRET~~~~SECRET~~
 Distribution: Amb \_\_\_\_\_  
 Hq \_\_\_\_\_  
 Army \_\_\_\_\_  
 Supply \_\_\_\_\_  
 Air 

M 20358

TO HQ TO ECIM

K-100

To SPAATE for MACDONALD signed DEANE. ~~SECRET~~

Information supplied by Russian intelligence as follows:

KARELIAN FRONT: On the 26th of July enemy aircraft have carried out a recon of the front lines and the rear. Recon was made by single JU-88 planes and groups of four fighters. 22 sorties have been recorded. Our recon has discovered at Khavuvara - 4 fighters. Vyartsilya - 15 fighters.

LENINGRAD FRONT: On the 26th of July enemy aircraft has tried to interfere with the work of our aircraft. Singly and in pairs they carried out recon of the Karelian Isthmus in the direction of Narva. 35 sorties were recorded.

Our recon has found: Kakhula (photo) - 3 fighters. Rakvere (photo) - 36 fighters, of which 27 single engine. Tapa (photo) - no planes. Tallinn (photo) - 14 fighters. Tartu (photo) - 28 fighters, of which 21 JU-87a. Vykhma (photo) - no planes. Audru (photo) - 7 Mesch - 126.

THIRD NEAR BAL TIC FRONT - On the 26th of July enemy aircraft singly and in pairs, day and night, have carried out recon up to the boundaries of Karashevo, Shikhachevo. Two DO-215 bombed the station of Karashevo. 17 sorties were registered.

Aerial recon on 26th of July discovered: Porkhova - 6 fighters. Gulbene (photo) - 23 Mesch - 126.

SECOND, NEAR BAL TIC FRONT: On the 26th of July enemy aircraft in groups up to 16 FW-190 and ME-109 attacked ground forces in the regions of Resekne, Dvinsk

1

0877

SECRET

Enemy recon by single planes and fighter pairs was carried out in the region of Velikye Luki, Nevel. 172 sorties were registered, of which there were 97 MiG-109, 53 FW-190. Totalized results for July 25th give 196 sorties, of which 156 FW-190.

Our recon of July 26th discovered: Gulbene - 29, GO-145, and AR-56. Taukuli - 22 planes, of which 16 FW-190.

FIRST, NEAR BALTIC FRONT: On the 25th of July enemy aircraft in groups of 12 FW-190 attacked our ground units in the Shauli direction. Single aircraft carried out recon of the front lines and the rear. 100 sorties were registered.

Aerial recon of July 25th discovered: Dvinsk (west) - 15 FW-190, Krustpils - 15 aircraft. MZ. Birzha - 80 aircraft, of which 20 bombers. Keydany - 20 fighters.

SECOND BYALORUSSKY FRONT: On the 26th of July enemy aircraft in a group of 14 Ju-87s attacked our units on the front lines. Their fighters tried to interfere with the work of our aircraft. Singly and in pairs recon was carried out of the front lines and the rear. 44 sorties registered.

Aerial recon of July 26th discovered: Suvalki - 10 single engine aircraft. Ltzen - 6 twin-engine aircraft. No aircraft were discovered on the following airbases: XXII Aris, Kolno, Ossovets, Lomsha.

FIRST BYALORUSSKY FRONT: July 24th there was no enemy aerial activity.

SECRET

2

M49

0878

SECRET

No data on enemy sorties. Aerial recon of July 24th discovered: Bryansk - 15 fighters.

FIRST UKRAINIAN FRONT: July 25th enemy fighter aircraft tried to interfere with the work of our aerial units. Singly and in pairs they carried out recon of the front lines and the rear. 30 sorties were registered.

Aerial recon of July 25th discovered: Lisiatytshe - 42 aircraft. Strij - 30 aircraft.

July 26th enemy aircraft composed of small bomber groups attacked our troops on the front lines. Groups of fighters escorted group units and single planes carried out recon of the front lines. 74 sorties were registered.

Aerial recon of July 26th did not discover any planes on the airdromes of Baltovn, Sandomir.

SECOND UKRAINIAN FRONT: On the 26th of July enemy fighter aircraft, singly and in pairs, carried out recon front line and rear. 62 sorties were registered.

Aerial recon of July 27th: Roman - 16 aircraft. Sakau (photo) - 25 aircraft of which 19 JU-87. Klushi - 50 aircraft. Kishinev - 20 aircraft.

THIRD UKRAINIAN FRONT: On July 26th enemy fighter aircraft, singly and in pairs, carried out recon up to 100 km in depth. Groups up to 3 ME-109s covered the regions of Komrat, Bessarabysaa. 20 sorties were registered. More precise data of July 25th gave 28 sorties.

THIRD BYALORUSSKY FRONT: July 26th enemy aircraft bombed and attacked our

SECRET

M49

SECRET

ground units and ferries across the River Nieman. In pairs and in fours PB-190's carried out recon of the front lines and the rear. 50 sorties were registered. Additional data for July 25th registered 76 sorties. Aerial recon for July 26th established: Koneigsberg - up to 30 aircraft, Aris - 7 aircraft, Lykk - 1 aircraft.

Additional data on the front against the USSR: On July 25th 811 sorties were registered. July 26th - 496 sorties were registered.

Miscellaneous: According to the latest information recently a great number of German aircraft units have been concentrated on the airdrome UTII. Aircraft are carefully camouflaged on the outskirts of the woods surrounding the airdrome. Largest number of aircraft is usually noticed between 11 and 13 hours.

Aerial recon of air bases has discovered: Subalki - one group first bomber fighter Geschwader (previously at Warsaw). Tomashuv - 2 groups 56th bomber Geschwader (previously at Demblin). Zheshuv - 8 squadron 10th group of tactical recon, 1st squadron 21st group tactical recon, and 5th squadron 32nd group tactical recon. Krosno - 3rd group 53rd bomber Geschwader (previously Strij). Byriad - 5th group 3rd bomber Geschwader Roumanian (previously at Konstantza). Buda-pest - 2nd group 3rd night fighter Geschwader (previously aircraft operated in the region of the Mediterranean). Operations of one group of 101st bomber Geschwader has been confirmed on the airdrome of Riga. 2nd group 4th bomber Geschwader on the airdrome of Insterburg, and 3rd squadron 121st recon group on the airdrome of Tekhutchi have also been confirmed.

SECRET

4

M49

0880

Conclusions:

1. Within the boundaries of Resakne, Vistki the enemy continues to move units by auto transport towards the west.
2. In the region of Grodno the enemy has brought in by auto transport additional reserves from the west, simultaneously some of the units in the region west of Grodno have been moved west.
3. Within the boundaries of Khodorov, Kaluzs enemy ~~continues~~ continues to move its units to the west.
4. Within the boundaries of Krasnystav, Zamostie the enemy is moving troops in large units to the west.

This data supplied by WSCOM. Please advise your reaction to the above information, when the ~~Russians~~ Russians supply it do you wish it in full or if not indicate which part.

British here very anxious this information reaches Air Ministry without delay.

M 48  
5 (END)

ADMAR Washington

Frankie

S

JWS

Feldstein

~~SECRET~~*East Co.*

WARI 71823

27 July 44

282320E

272029E

~~SECRET~~  
Priority

AFM. Pass to Baker information Connolly Spaatz Deane

Freezing of that part of mission 18 personnel and equipment originating in MTO which is scheduled to move by air, until Soviets have approved entry into USSR, is satisfactory. Reference your MX 26083 dated 26 July 44. However, suggest that you continue movement of personnel and equipment listed as part 3 of your MX 72223 dated 14 July 44, which is scheduled to proceed by ship and overland to PCC. Similarly, 427th Night Fighter Sq now enroute by ship from US to North African Ports should be permitted to proceed, as ATO has made all arrangements to move this squadron immediately upon debarkation. Expect Soviet approval for entry by time this squadron and that part of your personnel moving by water arrives at Teheran. If not, as indicated in his MX 17091, Connolly will have to temporarily accommodate this personnel.

*Lifo*~~SECRET~~

0882



*Ex Com*

24 July 1944

M20273

Hq USSTAF

Swedish Ball Bearings

Gen Walsh/cw

Routine

~~Secret~~ Secret

*John  
ops*

To Spatz from Walsh signed Deane ~~SECRET~~

Ambassador has contacted foreign office notifying our willingness to accomplish project transferring ball bearings from Sweden to Russia and stating conditions under which we will have to operate. Soon as project approved foreign office assume we will contact air officials and work out details. Deane delayed and due back from Russian front today. It is possible he may not be able to depart tomorrow. He will be briefed on subject prior departure here

ALL INFORMATION CONTAINED HEREIN IS UNCLASSIFIED  
DATE 27 SEP 88 BY Thomas / Mals  
NAME DATE

~~SECRET~~  
R30

M22

0883

24 July 1944

# 20283

USSTAF

SMW

Frantic Operations

WLS

Walsh Typist: Feldstein

Operational Priority

242080Z

~~SECRET~~

CC

Personal for Spaatz from Walsh signed Deane ~~SMW~~ SMW

From Escom sent you a radio reference future program and indicated we should have maximum operations to about September 15th and restricted or reduced operations during fall then bases should be moved to forward locations. Harriman and Deane concur but prior making formal request to Foreign Office Harriman desires concurrence you and General Arnold.

*Harriman*

M 20

0 8 8 4



0 8 8 5



0 8 8 6



0 8 8 7



0 8 8 8



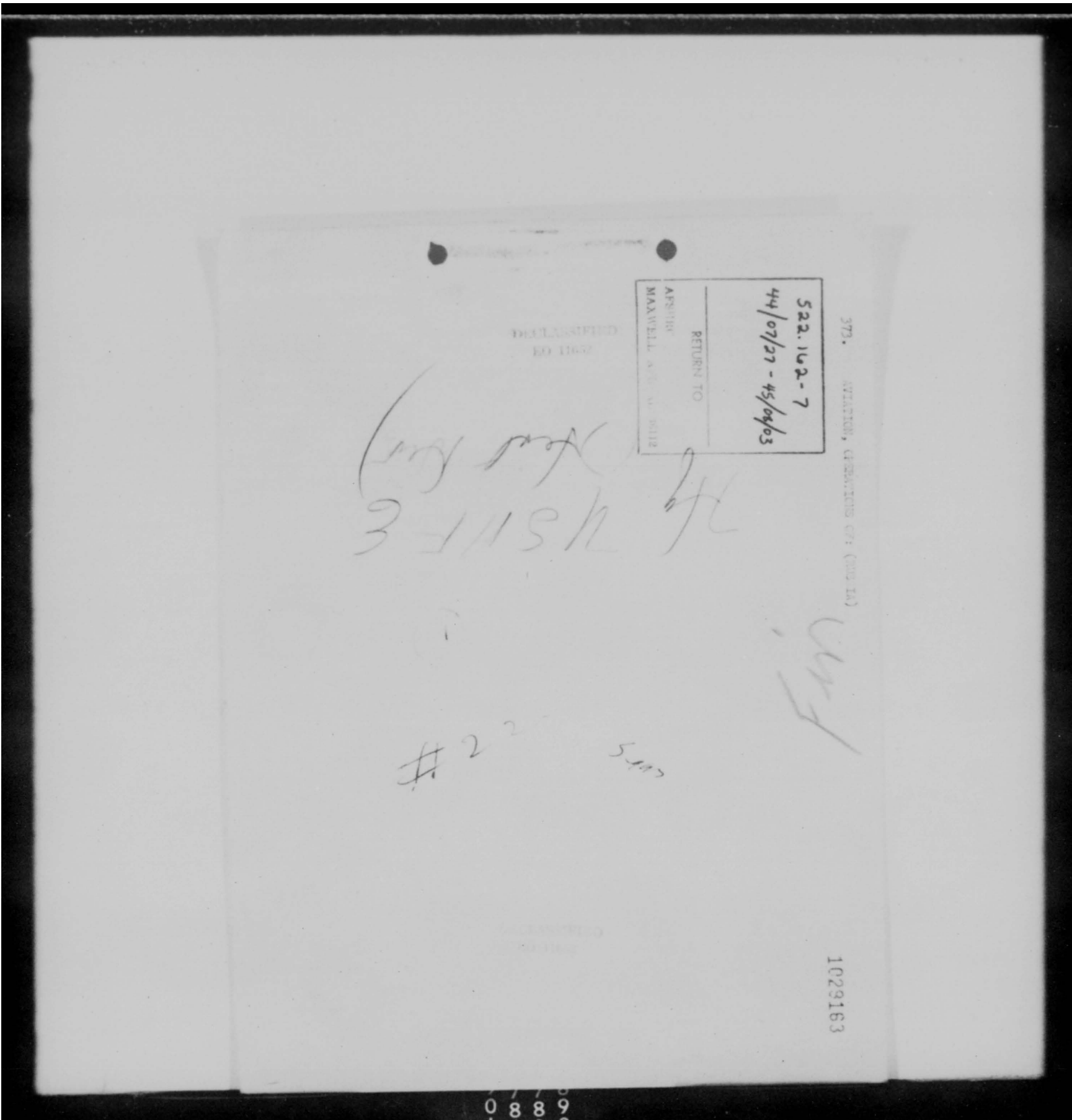



**CONFIDENTIAL**

HQ, US STRATEGIC AIR FORCES IN EUROPE

**INCOMING MESSAGE**

EDITED LITERAL TEXT

ROUTINE ~~SECRET~~

|                                  |           |                        |
|----------------------------------|-----------|------------------------|
| ASSIGNED<br>MANWELL AIR AT 2011R | RETURN TO | 522.162-7              |
|                                  |           | 44/07/27 -<br>45/08/03 |

IN REPLY CITE: MX 58568

3 AUG

FROM: AAF WFO 031456B

INTERNAL ADDRESS:

TO : HQ USSTAF 032045B

TO : CG USSTAF MAIN AND REAR  
FROM: CG AAF HSD

Movement of 10 C-47 loads of Russian Nationals Bolzano to Pilsen on 30 July and 1 C-47 with 14 Czech Air Evacuation patients Verona to Pilsen on 2 August completed without incident. Airbase at Pilsen found to be in good condition, no radio contact, no flying personnel at field, base operations conducted by ground personnel of 3rd Army, 3000 foot runway and no servicing facilities. No difficulties were experienced and the only Russian personnel encountered were drivers of trucks meeting the aircraft.

D/PH Planning  
Master File Copy

USSTAF DISTRIBUTION:

ACTION: A-3

INFO : AG RECORDS

A-2  
A-5  
A-1  
C/S  
CG

USSTAF IN 53034

|         |   |
|---------|---|
| A       |   |
| 4/1 N30 |   |
| 3       |   |
| LA      |   |
| A       | B |
| Be      | C |

1029163



DECLASSIFIED  
EO 13526

EXEMPT FROM AUTOMATIC  
DECLASSIFICATION AND  
DOWNGRADING BY THE  
SECRETARY OF DEFENSE

THE MAKING OF AN EXACT COPY OF THIS MESSAGE OR ANY PART THEREOF IS FORBIDDEN IF ADDITIONAL COPIES ARE NECESSARY, THEY WILL BE PARAPHRASED VERSIONS AND WILL BE MARKED WITH THE SECURITY CLASSIFICATION INDICATED HEREON THE COPY WILL BE SAFEGUARDED WITH THE GREATEST OF CARE.

~~CONFIDENTIAL~~

0890



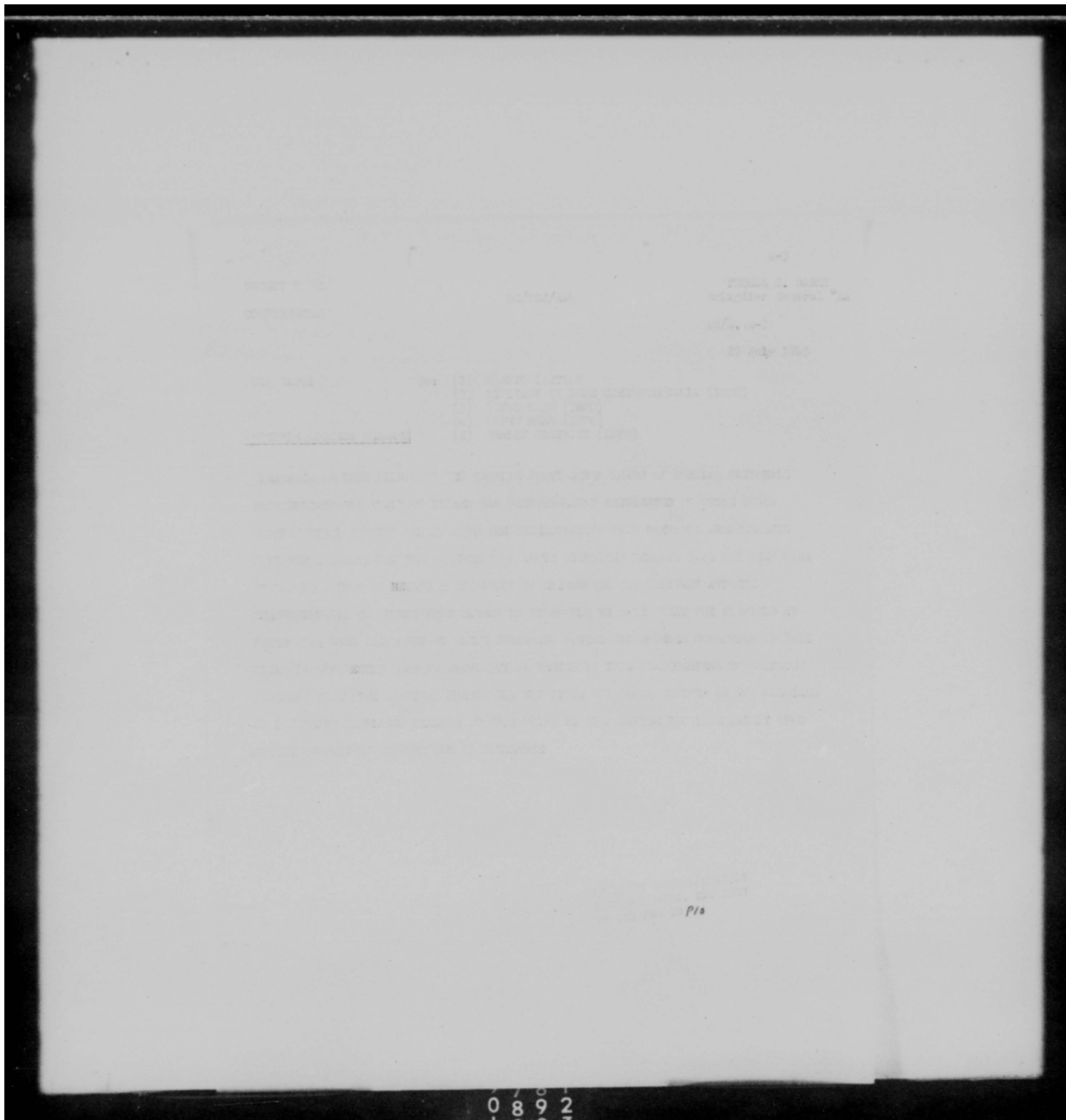

0 8 9 2

**CONFIDENTIAL**  
 HQ, US STRATEGIC AIR FORCES IN EUROPE  
**INCOMING MESSAGE**  
 EDITED LITERAL TEXT

|            |                               |
|------------|-------------------------------|
| DATE       | 20/7 AM                       |
| TIME       | 3                             |
| CLASS      | —                             |
| INITIALS   | <i>[Handwritten initials]</i> |
| STATUS     | OK                            |
| FILE       |                               |
| SEARCHED   |                               |
| INDEXED    |                               |
| SERIALIZED |                               |
| FILED      |                               |

OF PRIORITY      CONFIDENTIAL

In reply to: IS 512 July 29

FROM: HQ USAF CASERTA

TO : USSTAF

INTERNAL ADDRESS:

FROM: HQ NATO TRAFFIC NAPLES  
 FOR: USAF  
 TO: G4 AFHQ, HQ USAF OPS,  
 USEET MAIN FRANKFORT,  
 USEET REAF PARIS,  
 CONTINENTAL FILING CONTROL,  
 AIRCRAFT SAFETY CENTER IN FRANCE,  
 USSTAF, BASE OPS BOLZANO ITALY,  
 BASE OPS PILSEN AIRFIELD  
 CZECHOSLOVAKIA, 5TH ARMY SURGEON  
 FOR COLONEL CARNADELLA,  
 PILSEN RECEPTION CENTRE PILSEN  
 (USSTAF MAIN PSE PASS 5TH 9TH AND  
 11TH ADDRESSES)

This TOO 291710Z. As requested by 5th Army Surgeon thru G4 AFHQ NATO will move 10 C-47 loads of Russian Nationals from Bolzano to Pilsen on 30 July. Vertical clearance received from USAF Ops for flight on 29 July. Aircraft will depart Bolzano 0600Z arrive Pilsen 0800Z unload and return to home base in Italy same day. Contact at Bolzano is Colonel Carnadella Hq 5th Army. Contact at Pilsen is Pilsen Reception Center

USSTAF DISTRIBUTION:

ACTION: A-3

INFO: A-2

A-1

A-5 ✓

ATSEC

C/S

USSTAF : BY

AG RECORDS

USSTAF IN 51044



THE MAKING OF AN EXACT COPY OF THIS MESSAGE, OR ANY PART THEREOF, IS FORBIDDEN. IF ADDITIONAL COPIES ARE NECESSARY, THEY WILL BE PARAPHRASED VERSIONS AND WILL BE MARKED WITH THE SECURITY CLASSIFICATION INDICATED HEREON. THE COPY WILL BE SAFEGUARDED WITH THE GREATEST OF CARE.

**CONFIDENTIAL**

0 8 9 3

~~TOP SECRET~~

HQ, US STRATEGIC AIR FORCES IN EUROPE  
INCOMING MESSAGE  
EDITED LITERAL TEXT

PRIORITY ~~TOP SECRET~~

In reply cite: W 79416 9 May 45

From: SAC

Internal address:

To: AICG JCS JJJ JMS

To : Eisenhower  
For : Spotts  
Info : Deane  
From : McFarney  
Sgt : Marshall

Re: MX 24203 (USSTAF MAIN IN 35264 T.S.)

Policy outlined in Deane's MX 24203 approved.

It is desired that you have Spotts take necessary action as requested in paragraph 4 of subject message to evaluate Poltava.

USSTAF MAIN DISTRIBUTION:

Action: D/Ops (5)

Info : D/C USAF  
D/Class (3)  
D/Pers  
D/Intel (5)  
AICG  
Gen. Knerr  
D/Supply  
C/S  
USSTAF ADV  
E. S. Cantel

USSTAF MAIN IN 35264

373.52

|          |
|----------|
| 10/5     |
| 3        |
| -        |
| A-G      |
| WESLEY A |
| B        |
| C-3      |
| C-1      |
| SPR C-7  |

TS-13764

6-0763

THE MAKING OF AN EXACT COPY OF THIS MESSAGE OR ANY PART THEREOF IS FORBIDDEN IF ADDITIONAL COPIES ARE NECESSARY, THEY WILL BE PARAPHRASED, REPHRASED AND WILL BE MARKED WITH THE SECURITY CLASSIFICATION INDICATED HEREON. THE COPY WILL BE SAFEGUARDED WITH THE GREATEST OF CARE.

TOP-SECRET

0894

| FILE CHARGE-OUT CARD   |                 |  |
|--|-----------------|--|
| TAKEN BY   | DATE            | IDENTIFICATION OF RECORD   |
| ARUNSKI  | 9 OCT 52        | WT 5085 200  |
|  |                 | WT 6403 201  |
|  |                 | WT 6403 208  |
|  |                 | WT 6403 207  |
|  |                 | WT 6403 206  |
|  |                 | WT 6403 210  |
|  |                 | WT 6403 212  |
| <p><i>[Faint handwritten notes]</i></p>  |                 |  |
| <p>MS 14650 doctrop car file CW 4890-229330 <i>[illegible]</i> 10/11/54</p>                  |                 |  |
| <p>Compt AIRS<br/>i of <i>[illegible]</i> to 44205</p>                                       | <p>11/11/54</p> | <p>7 folders - Port John F. Thorsow<br/>12 Jan 49 - 3 Jan 50</p> |
| <p><i>[Faint handwritten notes]</i></p>  |                 |  |
| <p>For Messages Top Level Control<br/>Regiment No G-0738, G-0740, G-0660<br/>See TS # 37</p> |                 |  |

SECRET

HQ US STRATEGIC AIR FORCES IN EUROPE

INCOMING MESSAGE

EDITED LITERAL TEXT

Lack

PRIORITY SECRET

IN REPLY CITE: H-23734 7 April 1945.

FROM : USMILMIB MOSCOW 071415Z INTERNAL ADDRESS:  
 TO : USSTAF 071727B TO : SPAATZ  
 FROM : HULL  
 SGT : Deane

REF: DA-23516 March 29 is USSTAF IN 26595

Have decided to carry into effect my suggestion made in my DA-23516, 29 March, regarding the relief of Colonel Thomas K. Hampton from Command of the Poltava Air Base. As the retention of Lt Col Mervin L. Alexander would result in an inversion of rank, have decided to relieve him also. This will leave Major Michael H. Kosal in Command.

Information is requested earliest possible as to whether it is desired that Hampton and Alexander be returned to the United States or to USSTAF. If you desire former action, request appropriate orders be issued. If the latter, I will issue necessary orders immediately upon receipt of indication of your desires. Hampton and Alexander have been alerted this date.

USSTAF MAIN DISTRIBUTION:

ACTION : *PERS*  
~~MILITARY~~ (3) ✓ *Copy H*

INFO : D/OPS (5)  
 D/CG OPS  
 USSTAF ADV  
 GEN MGRM  
 C/S  
 AG RECORDS

| DATE RECEIVED |    |
|---------------|----|
| 7/1           | 20 |
| 7/2           | 3  |
| 7/3           |    |
| 7/4           |    |
| 7/5           |    |
| 7/6           |    |
| 7/7           |    |
| 7/8           |    |
| 7/9           |    |
| 7/10          |    |
| 7/11          |    |
| 7/12          |    |
| 7/13          |    |
| 7/14          |    |
| 7/15          |    |
| 7/16          |    |
| 7/17          |    |
| 7/18          |    |
| 7/19          |    |
| 7/20          |    |
| 7/21          |    |
| 7/22          |    |
| 7/23          |    |
| 7/24          |    |
| 7/25          |    |
| 7/26          |    |
| 7/27          |    |
| 7/28          |    |
| 7/29          |    |
| 7/30          |    |
| 7/31          |    |

D. PH. P. [unclear]  
 [unclear] 37357

USSTAF MAIN IN 28515

THIS MESSAGE IS AN EXACT COPY OF THIS MESSAGE, OR ANY PART THEREOF, IS FORWARDED IF ADDITIONAL COPIES ARE NECESSARY, THEY WILL BE PARAPHRASED AND WILL BE MARKED WITH THE SECURITY CLASSIFICATION INDICATED HEREIN. THIS COPY WILL BE SAFEGUARDED WITH THE GREATEST OF CARE.

SECRET

0896







| FILE CHARGE-OUT CARD                               |                    |  |
|--|--------------------|--|
| TAKEN BY   | DATE               | IDENTIFICATION OF RECORD   |
| <del>Shaw</del>                                    | 11/1/55            | 50's 1950<br>#194-000  |
| WALWON AHS   | 1-23-55            | <del>WALWON AHS</del><br><del>CHARGE-OUT TO</del><br><del>WALWON AHS</del> |
| <del>WALWON AHS</del>                              | <del>1-23-55</del> | <del>WALWON AHS</del><br><del>CHARGE-OUT TO</del><br><del>WALWON AHS</del> |
| Gates Loan to dig etc                              | 3-5-56             | TL 6278-6279 (2)<br>K. Gates Property - Aug 1975<br>Plot 2                 |
| Chuney case  | 24 Sept 56         | outbill<br>WV 6600501-600  |
| Low-For KC Dist Group                              | 26 Nov 56          | Ents 380.01 Safeguards<br>Military Information Vol 2                       |
| For Files Manager TSCR#<br>102A, 103A, 105A, e-100 |                    |  |
| In TSA 37  | 26 Feb 57          | Emergins   |

OUT  
 25/126  
 U-7041

21 Sept 56  
 Army PM A  
 5/15/57

P/10/10

traffic bases

1. Present to verbal request of Col Miller for comments of W/Flms on proposal of closing out the "Cratic" bases the following comments are offered:

2. Present to verbal request of Col Miller for comments of W/Flms on proposal of closing out the "Cratic" bases the following comments are offered:

a. It is desirable to retain cratic bases in the DOD areas of responsibility for:

- (1) Production of R's and have been issued by the DOD.
- (2) To law legislation support to DOD bases. DOD has been placed on their side for controlling all DOD bases introduced into Soviet controlled areas with general DOD in charge.
- (3) Leading all and expansion of heavy DOD areas which have been forced into Soviet controlled areas.
- (4) Possible source of favorable effect in establishment of Air Transport Command bases in DOD.
- (5) Giving all all possible and logistical and administrative support of DOD special missions.
- (6) Furtherance of the American Soviet relationship into closer friendship and serving as direct DOD liaison with the Soviets.

373.52

*cut*  
*NY*

373.54

3. It is recommended that consideration be given to the above comments with reference to the proposal of closing out "Cratic" bases.

Walter B. SMITH  
Colonel, U.S.A.  
Director, Staff Plans

SECRET

*Handwritten initials*

0890

**SECRET**  
**US STRATEGIC AIR FORCES IN EUROPE**  
**INCOMING MESSAGE**  
 EDITED LITERAL TEXT

URGENT SECRET ROUTINE

IN REPLY CITE: CS 742 JB 31ST MARCH

31 Mar 45

FROM: CASERTA 311433A VIA USSTAF REDLINE  
 311510A

INDIVIDUAL ADDRESS:

TO : SPATZ BEINS

TO : USSTAF MAIN 311503A

FROM: GANDON

REF: UM6696

Reference your UM6696, reference establishment of bases in the Budapest area, I have taken this up with General McMorney and he heartily concurs that the need no longer exists for these bases. I am in complete accord with the opinion of your headquarters that immediate steps should be taken to inform the Russians that the Budapest area bases no longer constitute operational requirements. Upon further word from you, I will inform Hall to return to Italy immediately.

USSTAF MAIN DISTRIBUTION:

ACTION: 1/OPS (5)

INFO : D/C OPS  
 D/INTEL  
 USSTAF ADV  
 C/S  
 TS CONTR  
 D/PLANS (3)  
 ATCE (2)  
 GEN ENHR

USSTAF MAIN IN 26910

FOR THE DIRECTOR  
 AIR FORCE  
 WASHINGTON, D. C.



THIS MESSAGE IS AN EXACT COPY OF THE ORIGINAL. NO PART THEREOF IS TO BE REPRODUCED OR TRANSMITTED IN ANY MANNER WITHOUT THE WRITTEN PERMISSION OF THE AIR FORCE. IF ADDITIONAL COPIES ARE NECESSARY, THEY WILL BE PARAPHRASED AND WILL BE MARKED WITH THE SECURITY CLASSIFICATION INDICATED HEREIN. THE COPY WILL BE SAFEGUARDED WITH THE GREATEST OF CARE.

0901

**SECRET**

RE/79/21

Bi-Monthly Report on US Combat Aircraft  
Forced-landed in Soviet-Occupied Territory in the  
European T of Opns.

1 D/PHP D/Int 30 Mar  
Attn: 1945  
Lt.Col.  
Alexander

Attached hereto is letter, subject: Bi-  
Monthly Report on US Combat Aircraft Forced-  
landed in Soviet-Occupied Territory in the  
European Theater of Operations", Hq, Eastern  
Command, 1 March 1945, for your information.  
Please return.

GEORGE C. McDONALD  
Brigadier General, U.S.A.  
Director of Intelligence.

1 Incl:  
Letter, as noted.

D/I D/Plans 1 April  
1945

Noted by Lt. Col. Alexander.

1 Incl: n/c

THOMAS McDONALD Jr.  
Major AC  
Administrative Officer, Plans

**SECRET**

0902

SECRET

HQ US STRATEGIC AIR FORCES IN EUROPE  
INCOMING MESSAGE  
EDITED LITERAL TEXT

URGENT SECRET DELINE

IN REPLY DATE: 08 742 JS 31ST MARCH

31 Mar 45

FROM: CASERTA 311433A VLA USSTAF DELINE  
311530A

INTERNAL ADDRESS:

TO : USSTAF MAIN 311533A

TO : SPAATE RHINE

FROM: GAYDON

REF: UA66696

Reference your UA66696, regarding establishment of bases in the Budapest area, I have taken this up with General McKinney and he heartily concurs that the need no longer exists for these bases. I am in complete accord with the opinion of your headquarters that immediate steps should be taken to inform the Russians that the Budapest area bases no longer constitute operational requirements. Upon further word from you, I will inform Hall to return to Italy immediately.

USSTAF MAIN DISTRIBUTION:

ACTION: W/OPS (5)

INFO : D/C OIG  
D/INTEL  
USSTAF ADV  
C/S  
TS COMTL  
D/PLANS (3)  
W/SEC (2)  
OIG: W/SEC

USSTAF MAIN LN 26919

1/4 0930  
3

D/PA A-✓

A-1

C

1/4 0930  
3

THIS MESSAGE IS AN EXACT COPY OF THE ORIGINAL MESSAGE. IF ADDITIONAL COPIES ARE NECESSARY, THEY WILL BE MADE FROM THE ORIGINAL MESSAGE AND WILL BE MARKED WITH THE SECURITY CLASSIFICATION INDICATED HEREON. THE COPY WILL BE SAFEGUARDED WITH THE SAME CLASSIFICATION.

SECRET

0903



HEADQUARTERS  
U. S. STRATEGIC AIR FORCES  
IN EUROPE

Date \_\_\_\_\_

FROM \_\_\_\_\_ Ext \_\_\_\_\_

TO:

MAJ GEN F. L. ANDERSON

COLONEL I. C. ODUM \_\_\_\_\_

COLONEL R. L. SNIDER *RLS*

MAJ J. S. PITTINGER \_\_\_\_\_

LT R. A. HOLME \_\_\_\_\_

CG \_\_\_\_\_ DCG/Adm \_\_\_\_\_

C/S \_\_\_\_\_ Dep C/S \_\_\_\_\_

D/O \_\_\_\_\_ D/PH \_\_\_\_\_

D/I \_\_\_\_\_ D/NS \_\_\_\_\_

FOR: *Approval*

Information \_\_\_\_\_

File \_\_\_\_\_

Action \_\_\_\_\_

*Has been coordinated  
with D/O.*

*This has been approved  
by Gen Anderson & Gen Gandy  
To be dispatched 1700 hrs  
1 Apr 50*

0 9 0 4

PRIORITY

W/RW

URGENT

DONALD B. SMITH  
Colonel, MC  
Director

30 MAR 45

Approved for S/G Operations \_\_\_\_\_

1AX 66802

US MIL KES (JMS)  
JSHL

ARRIVING IN FOR WILL TO EASTERN COMMAND WOULD BE AT TWO THREE FIVE AM ALL DATES  
 TWO NINE THREE IN WOULD BE AT TWO THREE FIVE AM FOR COOPERATION UNDER YOUR COMMAND  
 THREE MAJOR GENERAL WILL FORM TO EASTERN IN YOUR BASE COMMAND. FORM TO BE  
 INFO CANNOT BEHOLD SPARE PARTS UNDER YOUR COMMAND. FORM WILL CONTINUE TO  
 COMMAND ALL BASES IN REGIONAL TERRITORY UNDER THE NAME OF EASTERN COMMAND TO  
 POLKAVA BASES SHOULD NOT BE CLOSED UNTIL THE BASES IN THE MIDWEST AREA ARE READY TO  
 ADMINISTRATIVE RESPONSIBILITY FOR GETTING UP THE MIDWEST BASES AND GIVING LOGISTICAL  
 SUPPORT TO THE BASES HAS BEEN DELEGATED TO NINE AIR FORCE AND FIFTEENTH AIR FORCE  
 BUT WILL REMAIN UNDER YOUR COMMAND AS EASTERN COMMAND TO NINE AIR FORCE IN  
 CONFERENCE WITH YOU HAVE DELEGATED GENERAL HALL AS BASE COMMANDER OF BOTH BASES TO  
 THIS ONE HOWEVER ONE WILL NOT RELIEVE YOU OF YOUR RESPONSIBILITY AS  
 COMMANDER OF EASTERN COMMAND TO COME IN YOUR NEGOTIATIONS FOR RELIEVING HALL



D/PP



0905

| <br><b>CARRIER SHEET</b><br>HQ US STRATEGIC AIR FORCES IN EUROPE<br><small>Must remain with attached papers</small> |       |         |         |   |
|--|-------|---------|---------|---|
| <small>NUMBER EACH MEMO OR REPLY IN LEFT BORDER    DRAW LINE UNDER EACH AND INITIAL IN RIGHT BORDER<br/>           USE ENTIRE WIDTH OF PAGE</small>  |       |         |         |   |
| No   | TO    | FROM    | DATE    | SUBJECT    Eastern Command.   |
|  |       |         |         | <small>Enter File Classification AG</small>   |
| 1.   | D/PHP | D/C Ops | 30/3/45 | <p>1. The following information is quoted from this morning's staff meeting for your information:</p> <p>"1. <u>EASTERN COMMAND</u>. Reference was made to message from General Hill, USSTAF IN 26595 (MX 23516). It was decided that there is no wish to concur in General Hill's recommendation that Eastern Command be turned over to MAAF; also that the Poltava base should not be closed until the bases in the Budapest area are ready. Further, that MAAF is responsible for setting up and supplying the Budapest bases, but command will be under General Hill, as Eastern Base Commander, with General Hall as base commander of the two bases. A message to this effect, also saying that Hampton can be relieved, if General Hill deems that action necessary, will be dispatched immediately."</p> <p style="text-align: right;"><i>R. L. Snider</i><br/>R. L. SNIDER<br/>Colonel, Air Corps<br/>Executive</p> <hr style="border-top: 1px dashed black;"/> <p style="text-align: center;"><i>map. Approved -<br/>File in to be<br/>action taken<br/>HVP</i></p> <p style="text-align: right;">REGRADED<br/>ORDER OF THE<br/>SECRETARY OF DEFENSE</p> <p style="text-align: right;">373.52</p> <p style="text-align: right;">TOP SECRET</p> <p style="text-align: right;">73-985</p> |
| <small>PAGE No. _____    LIFT HERE    USE OTHER SIDE</small>   |       |         |         |   |

0906

**SECRET**
  
 HQ US STRATEGIC AIR FORCES IN EUROPE  
**INCOMING MESSAGE**  
 EDITED LITERAL TEXT  
 PRIORITY TOP-SECRET

IN REPLY CITE: WK 55532

19 MARCH

FROM: WAR 192140A

INTERNAL ADDRESS:

TO : JBUS 2001A1A  
 CASERTA  
 NAPLES

TO : EAKER  
 INFO: SPAATZ  
 FEEL: ARNOLD

REF : F 46017 NOT IDENTIFIED

Noted is Mc Narneys cited cable of 19 March 45 relative revised frantic plan.

Request that a copy of revised plan be sent to this Headquarters by Courier as soon as possible. Assume you are arranging with Deane direct for your and Hall's trip to Moscow.

USSTAF DISTRIBUTION:

ACTION: MAAF

INFO : D/OPS (5)  
 D/CS OPS  
 D/PHP (3)  
 D/INT (5)  
 C/S  
 USSTAF ADW  
 T.S. CONTROL

USSTAF IN 24409

|      |
|------|
| 70/3 |
| 3    |
| -    |
| ✓ A  |
| ✓ A  |
| B    |
| C    |
| C    |
|      |
|      |
|      |

THE MARKING OF AN EXACT COPY OF THIS MESSAGE OR ANY PART THEREOF IS FORBIDDEN IF ADDITIONAL COPIES ARE NECESSARY, THEY WILL BE PARAPHRASED PERSONS AND WILL BE MARKED WITH THE SECURITY CLASSIFICATION INDICATED HEREON. THE COPY WILL BE SAFEGUARDED WITH THE GREATEST OF CARE.

TOP-SECRET

0907



SECRET

HQ US STRATEGIC AIR FORCES IN EUROPE  
INCOMING MESSAGE  
EDITED LITERAL TEXT

373,52



19972

File  
acc.

THE MAKING OF AN EXACT COPY OF THIS MESSAGE, OR ANY PART THEREOF, IS FORBIDDEN IF ADDITIONAL COPIES ARE NECESSARY, THEY WILL BE PARAPHRASED VERSIONS AND WILL BE MARKED WITH THE SECURITY CLASSIFICATION INDICATED HEREON. THE COPY WILL BE SAFEGUARDED WITH THE GREATEST OF CARE.

0909





THIS PAGE IS DECLASSIFIED IAW EO 13526



0911

THIS PAGE IS DECLASSIFIED IAW EO 13526



HQ US STRATEGIC AIR FORCES IN EUROPE  
INCOMING MESSAGE  
EDITED LITERAL TEXT

373.52

373.52

SECRET  
BY 0913



NO PART OF THIS MESSAGE OR ANY PART THEREOF IS FORWARDED IF ADDITIONAL COPIES ARE NECESSARY, THEY WILL BE MARKED  
REASON AND WILL BE MARKED WITH THE SECURITY CLASSIFICATION INDICATED HEREIN THE COPY WILL BE RECLASSIFIED WITH THE

SECRET  
0913

HEADQUARTERS  
 U. S. STRATEGIC AIR FORCES IN EUROPE 114M  
 Office of  
 THE DEPUTY COMMANDER  
 for  
 OPERATIONS

Date 29/7/44  
 From Exec Ext. 153

To:

Maj. Gen. F.L. Anderson

*Col. Deane*  
 Lt. Col. W. J. Wrigglesworth

Major J. S. Pittenger

Lt. M. K. McCord

Com. Gen.  D/C Admin.

C/S  Dep. C/S

D/O  D/Plans

D/I  D/WS

For:

Information

File

Action

*Submitted as agenda for  
 meeting with Gen. Deane  
 at Gen. Anderson's  
 request.*

4 1125

SECRET

BL/VLI/lf

29 July 1944

D/PIANS

SUBJECT: Attachment of USSR Liaison officer to Hq. USSTAF  
TO : Major General J. R. Deane

1. Eastern Command, USSTAF, has since its inception steadily increased in size and importance. In future plans, Eastern Command is expected to assume a position of even greater influence and to play a greater part in our strategic bomber offensive.
2. As Eastern Command becomes a permanent force and the number of its operational missions increases, the need for direct and effective coordination between the USSR, Eastern Command and Hq. USSTAF becomes more apparent.
3. In order that all our relationships with the USSR can be coordinated directly, with the consequent improvement in speed and effectiveness, it would be desirable to have a liaison officer from the USSR attached to Hq. USSTAF.
4. The liaison officer should, if possible, be a Red Air Force officer who has had wide operational experience as well as one who is well versed in staff duties and procedures as practiced in the USSR.
5. It is requested that you immediately initiate the necessary action to accomplish this project.

F. L. ANDERSON  
Major General, U.S.A.  
Deputy Commander, Operations

CLASSIFICATION  
AUTH. AND DATE  
BY 100 93PIC

4 1124

SECRET

0915

SECRET

MEMORANDUM  
 UNITED STATES DEPARTMENT OF DEFENSE  
 Office of the Director of Intelligence

AF 34 306  
 HQ 33, U.S. Army  
 29 July 1944

SECRET  
 SUBJECT: Exchange of Information and Intelligence between U.S. Forces, Eastern  
 Germany and Russia.

TO : General Gurnea

1. Substantial progress has already been made in the exchange of intelligence and related information between U.S. Forces Headquarters, Eastern Germany and the Russian authorities. Extremely valuable material has been received through Eastern Germany and a considerable volume of important intelligence has been sent from this Directorate of Intelligence to Russia. However, it is realized that this greatly needed exchange of information has only just begun and that every effort should be made to increase and expedite it, with the view of obtaining the maximum possible exchange of air intelligence between the interested parties.

2. In order to provide you with some assistance as to the detailed information particularly desired by this Headquarters, the various sections of the Directorate of Intelligence have furnished references on their respective needs. These references are attached hereto as follows:

Enclosure "A" - Operational Intelligence  
 Enclosure "B" - Target Intelligence  
 Enclosure "C" - Follow-up on I/O and Deception  
 Enclosure "D" - Psychological Warfare  
 Enclosure "E" - Photographic Reconnaissance

3. While all of the information covered by the above Enclosures should be helpful it is suggested that perhaps first priority should be accorded the target intelligence on all. It is very much hoped that valuable assistance can be obtained from officials of Polish authorities who should have been in Russian hands.

4. One other matter which has given us concern is the apparent inability of Russian forces to recognize our aircraft, particularly single aircraft engaged on photographic reconnaissance missions. Information from both the 15th and 5th Air Forces indicates that some 24 pilots have been captured, or engagements have been suggested, by Soviet pilots in spite of the compliance with recognition signals and flight patterns. Accordingly, it is suggested that every effort be made to promote the training of Russian airmen in the recognition of the types of our aircraft operating on the Eastern Front.

SECURITY INFORMATION  
 EXCLUDED FROM THE LIST  
 OF UNCLASSIFIED INFORMATION  
 BY THE FBI 1/10

4 1126

SECRET

0916

SECRET

Memorandum to General Deane (cont'd)

29 July 1941

5. The imminent mission to Russia of Lt. Colonel O'Hara, of this Directorate of Intelligence, is also of great importance to this Headquarters. It is hoped that every effort will be made to insure that he has access to all available information. He is fully informed on all CASACOM subjects and is authorized to exchange information and views with the Russian authorities.

*George C. McDaniel*

GEORGE C. MCDANIEL  
Brigadier General, U.S.A.  
Director of Intelligence

3 incls.  
(Identified in body of memorandum)

SECRET

4 1127

0917



SECRET

EXHIBIT "A"

HEADQUARTERS  
UNITED STATES STRATEGIC AIR FORCES IN EUROPE  
Office of the Director of Intelligence

29 July 1944

OPERATIONAL INTELLIGENCE.

1. The Operational Intelligence Section is now furnishing the Eastern Command with the following information:
  - a. Weekly, by cable, the disposition and strength of the GAF on the Western and Mediterranean fronts, information regarding disposition and strength of German fighters on the Russian front which is available to us, changes in the GAF order of battle, and sorties by types flown by the GAF on the Western and Mediterranean fronts.
  - b. Monthly, by cable, estimates of GAF production and wastage.
  - c. Quarterly, by mail, the complete order of battle of the GAF.
  - d. Any specific requests from the Eastern Command are supplied promptly by cable, if practicable.
2. We are now receiving from Eastern Command the following information:
  - a. GAF order of battle and strength on the Eastern front from Russian sources.
  - b. GAF Prisoner of War information regarding order of battle, strength, and serviceability of units.
  - c. Sorties flown by the GAF on the Eastern front and estimates of wastage incurred.
  - d. Airfield interpretation reports based on photo reconnaissance.
3. Information already obtained through the Russian Command has been most helpful, and the flow of information is steadily improving. However, the following additional information is particularly desired for operational purposes:
  - a. Intelligence, revised and kept current from time to time, on the development and occupation of new airfields by the GAF on the Eastern Front.
  - b. Copies of detailed Prisoner of War Interrogation Reports of GAF personnel captured on the Russian Front.
  - c. Any appreciations of the fighting value of the GAF made from time to time by Russian Intelligence.

SECURITY CLASSIFICATION  
REVIEWED APRIL 1984  
BY SAS PER SSP/O

SECRET

-1-

4 1128

0918

SECRET

4. Request has previously been made for detailed information on German aircraft which have landed or crashed behind the Russian lines, or which have been captured in the course of the Russian advance. We have particularly desired "works numbers", especially from operational GAF types, and such other information derived from captured aircraft as might assist us in estimating production. A certain amount of this information has already been furnished through Eastern Command, but in most instances "works numbers" did not appear to be from recently captured aircraft. The importance of obtaining this information on as current types as possible cannot be over-emphasized.

4 1123

SECRET

0 9 1 9

**SECRET**

HEADQUARTERS  
UNITED STATES STRATEGIC AIR FORCES IN EUROPE  
Office of the Director of Intelligence

EXHIBIT "B".

TARGET INFORMATION

1. It is highly desirable from a Target Angle to obtain intelligence on the German oil situation from officials of Polish Refineries which are now in or may be in Russian possession in the near future. The information urgently desired is as follows:

- a. What is the German policy of refinery repairs.
- b. What Oil Refinery equipment is the most difficult to repair or obtain under present conditions.
- c. What particular product from Crude Oil is Germany stressing to refineries.
- d. What is known of Strategic Oil Stocks.
- e. To what extent is gasoline being doped with alcohol.
- f. Are there synthetic oil plants in Poland? How many? What is the production of each?
- g. Any information possible on the German oil position with regard to Production, Stocks, Consumption and planned substitutes.

EXHIBIT "B" - TARGET INFORMATION  
REFINERY EQUIPMENT  
PI/C

4 1130

**SECRET**

0 9 2 0

**SECRET**

HEADQUARTERS  
UNITED STATES STRATEGIC AIR FORCES IN EUROPE  
Office of the Director of Intelligence

EXHIBIT "C"

PRISONER OF WAR AND ESCAPE

1. The following matters relating to the above subject require consideration:

a. Establishment of a standard operating procedure whereby the Russians will cooperate with the U.S. Army Air Forces in the evacuation of escapers and evaders from country taken by the Russian armies or from adjacent countries where the evader has either made his own way or has been helped by partisan forces.

b. The acquisition of pertinent information re escape and evasion concerning the countries adjacent to Russia, and possibility of obtaining information on the number of American airmen down and in hiding in various Eastern European countries.

c. The proper personnel in Russia to handle these matters.

d. Security arrangements re escapers and evaders and arrangements for interrogation and prompt dissemination of such interrogation to this Headquarters. In lieu of interrogation and facilities for rehabilitation, is it possible for them to be returned expeditiously to the UK?

e. Status of negotiations in regard to seven American airmen now known to be held by Polish partisans.

2. While it is impossible to estimate the number of U.S. Army Air Force airmen who will go through Russia, it is believed that the present rate of Russian advance and the possibility of increased U.S. Army Air Force operation from territories adjacent to Russia will create a condition where there is at least strong likelihood of a considerable number of U.S. Army Air Force personnel coming into Russian hands. Accordingly, the whole subject of escape and evasion should be considered carefully and a sound operating procedure evolved in cooperation with the proper Russian authorities.

3. It is suggested, that, in so far as possible, plans should be laid along lines which would permit American authorities, in cooperation with the Russians, to operate in this field independently of other Allied agencies.

*p/0*

**SECRET**

4 1131

0 9 2 1

SECRET

HEADQUARTERS  
UNITED STATES STRATEGIC AIR FORCES IN EUROPE  
Office of the Director of Intelligence

SUBMIT #2

PSYCHOLOGICAL WARFARE

1. The advance of the Russian armies is being exploited to the fullest extent by the various U.S. agencies engaged in Psychological Warfare. This propaganda is being carried into Germany by U.S. Strategic Air Forces in Europe planes that drop leaflets over German cities.
2. It is requested that the above be brought to the attention of Russian Psychological Warfare Agencies and the possibilities of a mutual exchange of pertinent information on Psychological Warfare be discussed.
3. Close cooperation between those Russian agencies and the U.S. agencies, such as now exists between the U.S. and British agencies, would undoubtedly further the psychological warfare efforts.
4. It is requested that there be a regular exchange of:
  - a. Information on special events that afford particular Psychological Warfare opportunities.
  - b. General lines of propaganda.
  - c. Leaflets.

SECRET  
REF ID: A66000  
PIU

4 1132

SECRET

0 9 2 2  
1 2 7 7

SECRET

EXHIBIT "F"

HEADQUARTERS  
UNITED STATES STRATEGIC AIR FORCES IN EUROPE  
Office of the Director of Intelligence  
Photo Reconnaissance Sub-Section.

29 July 1944

1. It is recommended that steps be taken to insure the prompt flow of photographs and intelligence reports resulting from photo reconnaissance accomplished at Eastern Command to USSTAF and Eighth Air Force Headquarters. Intelligence material resulting from sorties flown by the Fifteenth Air Force has been reaching this Headquarters in a most expeditious manner, but no photographs and no intelligence material, with the exception of first-phase interpretation reports have been received from Eastern Command.
2. According to information received from Colonel Polifka, Commanding Officer, MAPPW, aerial film from Eastern Command, which has been forwarded to his Headquarters for second and third phase interpretation, preparation of target charts, etc., has, in several cases, been unaccompanied by pilot traces, plots, or even sortie or print numbers. It is felt that a lack of trained personnel and an inadequacy of necessary equipment are seriously handicapping operations at Eastern Command laboratory.
3. In view of the shortage of trained photographic personnel at Eastern Command it is recommended that every effort be made to obtain the necessary authority from the Soviet Government to increase our personnel by at least three more Laboratory Technicians and one additional Camera repairman.

P/O

SECRET

4 1133

-1-

0 9 2 3

COPY

SECRET

HEADQUARTERS  
UNITED STATES STRATEGIC AIR FORCES IN EUROPE  
Office of the Deputy Commander, Operations.  
APO 633

27 July 1944

MEMORANDUM FOR: Director of Plans

SUBJECT: Proposed establishment of a Russian  
Liaison Office in USSTAF

It seems to be desirable that a Russian Liaison Officer be attached to USSTAF in order that all our relationships with the Russians can be coordinated direct. In view of the fact that we with the Eastern Command have the only operating U. S. Forces in Russia, and due to the fact that most of our administrative contacts are air contacts, it is believed that this is necessary. Prepare the necessary papers for General Knerr to take to Russia to arrange this situation and also, a letter to General Eisenhower obtaining his concurrence prior to the departure of General Knerr.

F.L.A.  
F. L. ANDERSON  
Major General, U.S.A.  
Deputy Commander, Operations

Papers attached.

C.G.W.

PIU

SECRET

4 1134

0 9 2 4





0925



0926



0927



0 9 2 8

|                     |             |
|---------------------|-------------|
| 522.162-8           | APR 1962 TO |
| 44/05/02 - 44/10/02 | APR 1962 TO |
|                     | APR 1962 TO |

DECLASSIFIED  
13526

5-44

1029164

0929

2 October 1944

USSTAF, London

Aid to Poles in Warsaw

Walsh

URGENT

Asb:  
Eqs:  
CAS:  
Air: ✓  
Walsh:

Chluzsky (Carter)

~~SECRET~~

021850Z

To SPAATZ from DEANE and WALSH

M-21298

Follows resume and opinion requested in UX-68766: When Mikolaichik was in Moscow early in August it is understood Marshal Stalin informed him that he would send assistance to the Poles in Warsaw. We were informed that an effort to send Soviet liaison officers to contact the Poles in Warsaw had been unsuccessful and that the liaison officers who dropped were presumably killed or at least disappeared.

On 13 August, we received a memorandum from the British Military Mission stating that Warsaw had informed London that immediate aid was necessary, otherwise there would be a collapse of the Polish underground army in a few days.

On August 14 we received a cable from you stating that you intended to drop aid to Warsaw in FRANTIC 6 and asked for Soviet clearance. Our Ambassador contacted the Soviet Foreign Office and the Military Mission contacted the Soviet military authorities with the result that on 15 August we sent you a message stating that the Foreign Office had informed the Ambassador that the Soviet Government did not concur in using FRANTIC 6 to drop supplies to Warsaw. Both the American and British Ambassadors protested the Soviet decision but the Soviets stood firm describing the

CLASSIFIED BY 6880  
DECLASSIFIED TO SECRET  
DATE 11 SEP 88  
BY 6880

~~SECRET~~

EXCLUDED FROM AUTOMATIC  
DECLASSIFICATION  
BY 6880 25 H 3 1

0930



~~SECRET~~ SECRET

the Warsaw uprising as "adventuristic." Later the President sent a message to Stalin making a personal appeal to the Soviets to give assistance to the Polish partisans or to assist us in doing so. This appeal was rejected in a personal reply from Marshal Stalin and the matter was considered closed for the time being.

On 10 September the Soviet Government informed the British Government that if the British insisted the Soviets were prepared with reluctance to act jointly with the Americans and British in a plan to be concerted for dropping weapons, food, and other supplies for the assistance of the partisans in Warsaw. This was in response to a letter which had been sent to the Soviet Government by the British Government. Accordingly you were informed of this on 10 September in our MX-20918. In response to a directive which you received from General Marshall, FRANTIC 7 was organized originally for 13 September and received immediate Soviet approval. It was postponed because of weather several times but was finally run on September 18, the Soviets giving their concurrence for each day in the interim.

The Soviet agreement with the British indicated that a concerted plan should be worked out between the Americans, British, and Soviets. Burrows and Deane attempted to contact the Russians on several occasions to work out a concerted plan but the General Staff refused to meet with us. The Russians themselves started dropping supplies in small quantities during the night of 13 September and have continued to do so intermittently ever since. Apparently they thought approval of our flight plus what they were doing themselves eliminated the necessity for a concerted plan despite the fact that they themselves had said such a plan was necessary.

The Soviet attitude with regard to the partisans had apparently undergone

~~SECRET~~ SECRET

Page #2

0931



~~SECRET~~ SECRET

certain readjustments because the Ambassador had information from the highest Soviet authorities that the uprising on the part of the partisans was the result of a German ultimatum that all male citizens of Warsaw were to be evacuated to German concentration camps. Therefore they did not have much choice as it appeared they found death whether they were evacuated by the Germans or remained to fight. The Soviet authorities still deplored the fact they were not informed of the uprising in advance so they could coordinate with it and condemned Gen. Bor rjt Bor.

The Soviet General Staff indicated that FRANTIC 7 was not highly successful because over 50 per cent of the supplies drifted into German hands and suggested that we should change our technique if we contemplated another mission.

When FRANTIC 8 was requested on 30 September, it was approved promptly. We have no information concerning their refusal to approve the mission on October 2 other than that given to you in Kessler's T-1271 of 1 October. However on receipt of your UI-63765, a request was immediately sent to the General Staff telling them of the decision that had been given to Kessler were correct and asking for a reply not later than tonight. So far we have not received confirmation of the decision given to Kessler but will transmit it to you as soon as received.

The Soviet authorities have informed Kessler that all of the Polish partisans in Warsaw have been evacuated. The highest Soviet authorities have informed the Ambassador a week ago that there were not more than 3000 partisans fighting in Warsaw and that they were isolated in several small groups. We do not know how these reports may compare with those you have received through the Polish Government in London.

~~SECRET~~ SECRET

Page #3

0 9 3 2

~~SECRET~~ SECRET

Pending receipt of confirmation of the decision given to Kealar we feel we must accept it as expressing the Soviet attitude, and if it is we do not feel that they will change from it. We are reticent about persuading them to change their attitude for fear that they might grant approval provided we would guarantee that we fly low enough to insure the maximum amount of supplies reaching the Polish partisans. In this case we would strongly recommend that no changes be made in our technique. As the situation now stands we are in the favorable position of wanting to run the mission but unable to do so because of Soviet disapproval. On the other hand, if they approve under conditions that we are not prepared to accept, this will strengthen the Soviet position and put us in the light of not doing everything possible to aid the Poles.

~~SECRET~~ SECRET

Page #4 (KND)

0933

5 October 1944  
 Hq USSTAF, London  
 Aid to Poles in Warsaw  
 Walsh-Broese  
 Operational Priority  
 TOP SECRET

Amb:  
 Hqs:  
 G&S:  
 Air:  
 Walsh:

Carter

V-21254

~~SECRET~~ SECRET

To SPAATZ from DEANE and WALSH TOPSEC

Supplementing information and opinion forwarded in M-21258.

Morning paper has prominent article summarized as follows:

"Colonel Montier, Commander of Home Army in Warsaw (Armja Krajowa), in name of General Bor rpt Bor, has decided to capitulate in Warsaw handing over personnel and weapons to the Germans. He has rejected idea of breaking out of Warsaw, but some units who have refused to capitulate are fighting their way out. The first group, which after bitter fighting has broken out of Zoliborz, has already reached the right bank of the Vistula. Thus the leaders of uprising who did not consult the Soviets in beginning are continuing to follow only own selfish interests and they are ending the uprising by capitulating, without regard for the fate of the heroes who have risen and they prefer to surrender them to the Germans, rather than unite with the Polish forces in battle."

Harrison believes this explains Soviet refusal for FRANTIC 8 as stated in Keesler's radio T-1291 and that obviously Soviets will not approve further Warsaw missions.

CLASSIFICATION CHANGED TO SECRET  
 505 D.M. 2800 2, 27 SEP 52

S. Haines 3 Nov 54  
 NAME DATE

~~SECRET~~ SECRET

1 (END)

0934

~~TOP SECRET~~ SECRET

15 October 1944  
HQ USAFIB, Cairo  
Ankara  
Ambassador's Party

Amb  
Hq  
Caf  
Air  
Sup

MR 21356

Bond Friedman  
Priority  
Top Secret

~~TOP SECRET~~ SECRET

To BILBY and to TYNDAL from BOND signed DEANE

Ambassador's party in B-17 departing from Moscow, Tuesday, 17 October 1944, at 0800Z for Cairo viaoltava. Route fromoltava to Cairo is non-stop via Ankara, Adana and Beirut. Weather permitting, WPA at North Turkish Coast as now planned is 1010Z, 17 October 1944. Will attempt CW contact with Ankara on frequencies as given in your previous wire.

If any objections or difficulties ensue as result of above plan suggest you wire us immediately.

~~TOP SECRET~~

RECEIVED  
15 OCT 17 1944  
AIR

~~TOP SECRET~~ SECRET

1 (20)

0935

MAAF, Caserta

4-34339

Thalati's Departure

16 October 1944

MAB

16/12452

Orlansky

17/0900A

1194

~~SECRET~~

~~SECRET~~  
URGENT

To DEANE from WALSH signed SACER

Departing Caserta October 17 will meet Harrison in Casablanca  
on 18th.

*Information*

CLASSIFICATION CHANGED TO SECRET  
BY THE SEC. OF AIR OR  
DATE

~~SECRET~~  
BY THE SEC. OF ARMY

0936

ARM AIRWAYS COMMUNICATIONS SYSTEM  
MESSAGE FORM (Originator)

NAV DEPARTMENT  
MSG FORM NO. 24-A  
REVISED 1-1-42

The transmission of the following message is authorized: *Karl A. Langford*  
By order of the C.O. (Signature of Authorized originator) *Capt A.C.D. AFG*

|  |                        |  |
|--|------------------------|--|
| CRYPTO SECTION ACTION                      | MESSAGE CENTER RECEIPT | ORIGINATOR                                 |
| SECRET <input type="checkbox"/>            |                        | CAPT. M.H. GLICK                           |
| SENT CONFIDENTIAL <input type="checkbox"/> |                        | DATE                                       |
| IN CODE <input type="checkbox"/>           |                        | 22 MAY 1944                                |
| RESTRICTED <input type="checkbox"/>        | ROUTINE                | CLASSIFICATION                             |
| CRYPTOGRAPHY BY                            |                        | SECRET <input checked="" type="checkbox"/> |
| DATE TIME                                  |                        | RESTRICTED <input type="checkbox"/>        |
|  |                        | CONFIDENTIAL <input type="checkbox"/>      |
|  |                        | CLEAR <input type="checkbox"/>             |

|                |             |           |          |
|----------------|-------------|-----------|----------|
| MESSAGE NUMBER | ACTION      | ADDRESSER | PRIORITY |
| 3033           | WYUK        |           | P        |
|                | INFORMATION |           |          |

81 TENTS AND TOILET PAPER REFERRED TO IN YOUR CABLE TWO ZERO  
MAY NUMBER THREE FOUR FOUR ONE STILL REQUIRED PD KESSLER  
TO CONNALLY ~~SECRET~~ SECRET PD ALL OTHER ITEMS MAY BE CANCELLED  
PD TOILET PAPER ONE FIVE CASES URGENTLY REQUIRED SHIP  
IMMEDIATELY VIA AIR COLON TENTS ARE TO BE INCLUDED IN RAIL  
SHIPMENT PD NEW SUBJECT CONTENTS OF YOUR CABLE MAY TWO ZERO  
NUMBER THREE FOUR EIGHT NINE CONCURRED IN

CLASSIFICATION CHANGE TO SECRET  
USED AIR #200.9, 23 SEP 44  
*Edgar* *3/20/47*  
NAME DATE

MC-2  
23-0758 2

THE SECURITY OF THIS MESSAGE WILL BE SAFEGUARDED ACCORDING TO AR380-5-40, 41, 42.





0 9 3 8





0939



0940



0941

DECLASSIFIED  
EO 13526

522.162-9  
44/05/23 - 44/05/31  
RETURN TO  
AFSHRC  
MANWELL AFB AL 36112

*But  
message - 23 may - 31 may*

5-4945

1029165

0942

M/A London

Trip to Eastern Command by  
General Spalding reverse L/L  
Triplicate

MAB

13180

31 May 44

08010755Z

~~TOP SECRET~~  
Flavin

Deane, repeated to Arnold, from Spatz, signed Peabody.

To discuss matters re-handling reverse Lend Lease, Kessler requests  
General Spalding visit Eastern Command if duties permit and will send  
plane to pick him up Moscow any time you say. Please advise.

|                      |           |
|----------------------|-----------|
| 522.162-9            | RETURN TO |
| 44/05/23-44/05/31    |           |
| AFSHHC               |           |
| MAXWELL AFB TX 76112 |           |

227

1029165

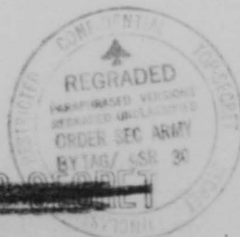

0943

PGC, Tehran

Communications Personnel

Duplicate *TRIPPLICATE*

MAB

*C. Kessler*  
PX14701

31 May 44

05312215Z

TOP SECRET

Flavin

P R I O R I T Y

Deane for Jewett, Kessler for Kilcoyne, from Ingles cite SPSGC-2 from Thomas, signed Connolly.

Golubowsky SGT and three men departed Tehran daylight. This completes shipment of personnel with exception of Colonel Thomas, one lieutenant and three men of PGC who are awaiting visas. 300 pounds of equipment destined for Poltava still on hand with departure now scheduled in two or three days.

*226*

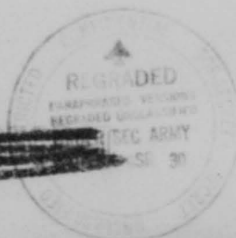

0944



546

HQ, MAAF

31 May 44

Route FRANTIC

Triplicate

05312310B

TOP SECRET

VIA BRITISH CHANNELS

Flavin

~~SECRET~~ SECRET

30 Mission for Deane from Hq, MAAF signed Baker.

Times and route referred to in my preceding message are:

Debrecen 0756GMT, Kotomyja 0822GMT, Paryatin 1005GMT, Mirgorod 1021GMT,

Poltava 1037GMT. Further details will follow. Acknowledge receipt

giving date and hour.

225

CLASSIFICATION CHANGED TO SECRET  
DDO DIR, A200-9, XI SER 22  
*E. H. Jones* Jan 17  
NAME DATE

SECRET

~~SECRET~~ SECRET

30

0945



HQ, MAAF  
Route PRANTIC  
Triplicate

VIA BRITISH CHANNELS

548  
31 May 44  
05312305B  
TOP SECRET  
Flavin

~~SECRET~~

30 Mission for Deane from HQ, MAAF Special Sigs Office signed BAKER.

Route and altitudes referred to in my earlier message are from base to Debrecen(4732 North 2139 East) to Kotomyja (4832 North 2503 East) to Piryatin to Mirogorod to Poltava. Fighters rendezvous with bombers at Debrecen and accompany them as far as Piryatin. Fighters altitude at Debrecen is 22,000 feet. Fighters altitude at Kotomyja is 25,000 feet. Bombers altitude at Kotomyja is 20,000 feet. At Kotomyja fighters and bombers start losing altitude at once, bombers descend to 10,000 feet, fighters to 11,000 feet. They will maintain these altitudes until reaching Dnieper IVEL. Bombers will then descend to 6,000 feet and fighters to 7,000 feet and will maintain these altitudes until bases are reached. Request you notify necessary authorities and acknowledge time of receipt of this message. This is the third of three messages on this subject.

CLASSIFIED BY 1045/1045/1045/1045  
DATE 22 SEP 88  
3/2/44  
1045

229  
~~SECRET~~  
R 30

~~SECRET~~

HQ, MAAF  
Route FRANTIC  
Triplicate

VIA BRITISH CHANNELS

*W. Kessler*  
D2(21 E 31(31May)

31 May 44

05312150B

~~SECRET~~

Flavin

~~SECRET~~

30 Mission for Deane from HQ, MAAF signed EAKER D2(21 E 31(31 May)

The execution date is 2 June. Please advise proper authorities.  
This information is being passed to Kessler by separate message. Details  
of routes and times will follow in next message. Acknowledge receipt  
giving time.

DECLASSIFICATION AUTHORITY  
DATE FOR REVIEW 11/11/00  
*E. Thomas* 1 Nov 79

223  
SECURITY CLASSIFICATION  
REVIEWED BY SEC AUTH  
BY 123 21 11 8 30  
~~SECRET~~

0947

*Weather  
Bill*

~~SECRET~~  
ARMY AIRWAYS  
COMMUNICATIONS SYSTEM

MESSAGE FORM (ADDRESSEE)

|                                       |  |
|---------------------------------------|--|
| RECEIVED IN:<br>SECRET CODE.... XXXXX | CRYPTOGRAPHY BY:<br>STEVENSON & HICKEY                   |
| CONFIDENTIAL CODE _____               | DATE/TIME:<br>28/1305Z                                   |
| RESTRICTED CODE _____                 |  |
| CLEAR TEXT..... _____                 |  |
| M 18528<br>.....<br>MSG NBR           | TO: KESSLER FOR MUNDALL                                  |
|                                       | FROM: BART (MMDQ)<br>MILLER SGD EAKER<br>FILED: 27/1529B |

**ROUTINE**

RECEIVED IN SECRET CODE

CONFUSION OF ADDRESSE CAUSING PAREN TO SPAAZ FOR YATES KESSLER FOR  
MUNDALL FROM MILLER SIGNED EAKER REF NR MIKE ONE EIGHT FIVE TWO  
EIGHT PAREN DIFFAULTY PD ALL ORDINARY WEATHER TRAFVXC MUST BE  
ADDRESSED TO WILLZWX UNCLE ROGER CHARLIE RPT WURC AT NAPLES  
PD ALL ADMINISTRATIVE MESSAGES FOR REGIONAL CONTROL TWELFNL  
WEATSER ADDRESSED IIG JIG HOW LOVE BEE JHNL CASERTA MUST

*Jan 17*  
*EX*

~~SECRET CLASSIFICATION  
REVIEWED BY THE SAC ARMY  
BY 1200 R 00~~

THE SECURITY OF THIS MESSAGE WILL BE  
SAFEGUARDED ACCORDING TO AR380-5:40.41

C-22 NR30 WURC 27

~~SECRET~~ SECRET

*28 1310*  
*149*

0948

~~SECRET~~  
ARMY AIR  
COMMUNICATIONS SYSTEM

MESSAGE FORM (ADDRESSEE)

|                                       |                        |                                |
|---------------------------------------|------------------------|--------------------------------|
| RECEIVED IN:<br>SECRET CODE.....XXXXX | MESSAGE CENTER RECEIPT | CRYPTOGRAPHY BY:<br>W.D.HICKEY |
| CONFIDENTIAL CODE _____               |                        | DATE/TIME:<br>26/1140Z         |
| RESTRICTED CODE _____                 | <b>PRIORITY</b>        |                                |
| CLEAR TEXT.....                       | PRECEDENCE             |                                |
| CS: 738<br>.....<br>MSG NBR           | TO: KESSLER            | FROM: MAAF<br>FILED: 280101B   |

THIS IS A PARAPHRASE BY MAAF CHPTO PD COMMUNICATIONS DATA FOR  
FRANTIC OPERATION IS SUBJECT BOTH LETTERS REFFED TO HEREIN OD XX  
TO SPAATZ CMA EAKER CMA KESSLER POLTAVA CMA AND DEANE U S MILITARY  
MISSION MOSCOW CMA MAAF CHARLIE SUGAR SEVEN THREE FIGEN NAN TARE  
UMA ITEM EASY ONE ZERO ONE FOUR NAN TAXE XX REFERENCE LETTER  
FIFTEENTH AIRFORCE DATED SEVEN MAY PARAGRAPH TWO CMA CALL SIGNS  
ASSIGNED FOR USE BY BOMB GROUP TO BE BASED AT PIRYATIN CALL BE  
USED BY SECOND BOMB GROUP WHO WILL BE BASED AT MIRGOROD LD CALL  
SIGNS ASSIGYLD FOR USE BY BOMB GROUP TO BE BASED AT MIRGOROD  
WILL BE USED BY FOUR SIX THREE BOMB GROUP WHO WILL BE BASED AT  
MIRGOROD PD CALL SIGNS ASSIGNED FOR BOMB GROUP TO BE BASED AT  
POLTAVA WILL BE USED BY NINE NINE BOMB GROUP WHO WILL BE BASED  
AT POLTAVA PD REFERENCE LETTER FIFTEENTH AIR FORCE DATED ONE  
THREE MAY PARAGRAPH ONE CMA CALL SIGNS ASSIGNED IN THIS PARAGRAPH  
WILL BE BY NINE SEVEN BOMB GROUP WHO WILL BE BASED AT POLTAVA  
PD FIGHTERS WILL AT PIRYATIN BE BASED

THE SECURITY OF THIS MESSAGE WILL BE  
SAFEGUARDED ACCORDING TO AR380-5:40,41

SECURITY CLASSIFICATION  
REVIEWED AUTH: ARMY  
BY 100 PER 95 R 30

~~SECRET~~

2811442

171

~~SECRET~~  
 ARMY AIRWAYS  
 COMMUNICATIONS SYSTEM

MESSAGE FORM (ADDRESSEE)

|                                       |                         |                                 |
|---------------------------------------|-------------------------|---------------------------------|
| RECEIVED IN:<br>SECRET CODE....XXXXXX | MESSAGE CENTER RECEIPT  | CRYPTOGRAPHY BY:<br>W.D. HICKEY |
| CONFIDENTIAL CODE _____               | <b>OP</b><br>PRECEDENCE | DATE/TIME:<br>29/2035Z          |
| RESTRICTED CODE _____                 |                         |                                 |
| CLEAR TEXT.....                       | TO: DUBITSKY            | FROM: NAPLES WURC<br>ASH        |
| ...NES. 7321.....<br>MSG NBR          |                         | FILED: 29/1126Z                 |

## RECEIVED IN SECRET CODE

WHAT YOU WANT IS THIS DUBITSKY FROM ASH SEE YOUR TOO TWO FIVE  
 ONETHROFIVEFIVEBAKER REFERENCE CALL SIGNS PD THESE ARE DIRECT  
 CONTACTS CMA MIKE MIKE DOG QUEEN CMA MIKE ABLE ABLE FOX SLANT  
 HOW QUEEN PD JIG JIG HOW LOVE CMA MIKE ABLE ABLE FOX REDLINE  
 CIRCUIT PD LOVE XRAY CHARLIE XEBRA CMA ONE TWO ABLE ABLE FOX  
 SUGAR CHARLIE PD MIKE JIG ABLE QUEEN CMA PETER BAKER SUGAR PD  
 LOVE DOG CHARLIE FOX CMA ABLE ABLE FOX SUGAR CHARLIE SLANT MIKE  
 TARE OBOE PD LOVE CHARLIE CHARLIE MIKE CMA SIX TWO FIGHTER WING  
 PD LOVE VICTOR CHARLIE XRAY CMA SIX FOUR FIGHTER WING PD ONE  
 TWO WEATHER HOW QUEEN PD RETRANSMISSIONS ARE NECESSARY FOR THE  
 FOLLOWING STATIONS CMA MIKE XRAY XEBRA CHARLIE CMA ABLE FOX  
 HOW QUEEN ADVANCE PD ABLE FOX HOW QUEEN REAR CMA WILLIAM YOKE  
 QUEEN LOVE PD LOVE DOG BAKER EASY CMA ONE FIVE ABLE ABLE FOX PD  
 LOVE XRAY BAKER YOKE CMA ONE FIVE ABLE FOX SUBAR CHARLIE PD  
 LOVE EASY WILLIAM ABLE CMA ONE TWO PD IS THIS SUFFICIENT PD  
 REQUEST ALL COMMUNICATIONS REGARDING ABLE ABLE CHARLIE SUGAR  
 FACILITIES TXMS STATION BE ADDRESSED THIS STATION COMPREHEND

THE SECURITY OF THIS MESSAGE WILL BE  
 SAFEGUARDED ACCORDING TO AR380-5:40,41 C-15 NR17 WURC 29

CLASSIFICATION CHANGED TO SECRET  
 EDD DIR. SEC. 5, 27 SEP 82

18 Jan 77  
 NAME DATE

292032  
 SECURITY CLASSIFICATION  
 REVIEWED WITH SEC ARMY  
 BY 120 PER 95 R 30

~~SECRET~~

0950



0951





0952





0953



0954

DECLASSIFIED  
EO 13526

|                                  |
|----------------------------------|
| 522.162-D<br>44/02/14 - 44/05/02 |
| RETURN TO                        |
| ATSHDC<br>MAXWELL AFB AL 36112   |

5 247

*This message withdrawn from file  
1468-22 msg*

1029166

0955

STANDARD FORM No. 14A  
APPROVED BY THE PRESIDENT  
MARCH 10, 1926

*File*

# TELEGRAM

OFFICIAL BUSINESS—GOVERNMENT RATES

FROM: WAR DEPARTMENT  
BUREAU

|        |           |                     |
|--------|-----------|---------------------|
| MAJSEC | RETURN TO | 522.162-10          |
| MAJVER | ARR. AT   | 44/02/14 - 44/02/22 |

FROM: NAPLES TO: POLTAVA FLD 22093PZ  
NES6252

ESSENTIAL WE KNOW COM FROM CUJO ~~SECRET~~ STATUS OF INSTALLATION  
OF THIS DATE CMA ALSO INFORMATION ON FREQUENCIES AVAILABLE FOR  
CONTACT CMA CONTACTS OVER TWO FOUR HOUR PERIOD MY RELIABLE AT  
PRESENT TIME CMA REQUEST INFORMATION IMMEDIATELY.

CLASSIFICATION CONTROL  
DOD DIR. 8200.9, 27 SEP 88  
*E. Thomas* 22/11/52  
NAME DATE

~~SECRET~~

*42 51*

*22/11/52*

*GFG*  
*22/11/52*

1029165

~~SECRET~~

STANDARD FORM NO. 14 A  
 APPROVED BY THE PRESIDENT  
 MARCH 10, 1932

*File*  
**TELEGRAM**

OFFICIAL BUSINESS—GOVERNMENT RATES

~~SECRET~~  
 FROM: WAR DEPARTMENT

BUREAU \_\_\_\_\_

FROM: JBPD - YATES

PRIORITY

C-10

TO : MUNDELL

~~SECRET~~  
 FILED: 221154Z

WILL USE GRID SYSTEM AND CODES YOU SUGGEST ED CMA HOWEVER  
 SUGGEST YOU CONSIDER CODE NOW HELD BY NICHOLSON WHICH IS  
 BEING USED FOR FORECAST EXCHANGE BETWEEN HERE AND FIFTEENTH  
 AIR FORCE WHICH HAS PROVEN SATISFACTORY PD COPY YOUR CODES  
 AS FURNISHED US IS BEING FURNISHED ITALY PAREN TOP SEC TO  
 KESSLER FOR MUNDELL FROM YATES SGD SPAATZ UNCLE SIX TWO FOUR  
 SEVEN TWO CITE ROGER ONE ONE SIX DATED TWO ZERO MAY PAREN  
 CODES AND INDICATORS BEING FORWARDED IN LETTER PD INDICATORS  
 AS REQUESTED ABLE ZERO ZERO ZERO SEVEN SEVEN OR ALTERNATE  
 CMA BAKER EIGHT FOUR FOUR FOUR EIGHT CMA CHARLIE EIGHT ONE  
 ONE ONE EIGHT CMA DOG EIGHT TWO TWO TWO EIGHT CMA EASY ZERO  
 ONE ZERO ONE ZERO CMA FOX ZERO THREE ZERO THREE ZERO CMA GEORGE  
 ZERO EIGHT ZERO EIGHT ZERO CMA HOW EIGHT THREE THREE THREE  
 EIGHT CMA ZERO ZERO ZERO THREE THREE FOR PRESSURE ALTITUDE  
 DATA IS INDICATOR CMA INDICATORS FOR ANALYSIS MESSAGES AS  
 FURNISHED NICHOLSON WILL BE USED WITH THE FOLLOWING ADDITIONS  
 P  
 CMA UPHER WARM FRONT FOUR SIX FIVE FIVE SEVEN CMA UPPER COLD  
 FRONT SEVEN FIVE ONE SIX ONE PD THE INDICATOR FOUR FOUR FOUR  
 NINE NINE WILL BE PLACED AT RANDOM WITHIN THE FIRST TEN GROUPS

CLASSIFIED IN CHANGED TO SECRET  
 DOB BY 14004 27 SEP 84

DATE  
 NAME

SECRET  
 DEPARTMENT OF THE ARMY  
 WASHINGTON, D. C. 20315

~~SECRET~~

59

0957

STANDARD FORM NO. 14 A  
 APPROVED BY THE PRESIDENT  
 MARCH 10, 1925

**TELEGRAM**

OFFICIAL BUSINESS—GOVERNMENT RATES

FROM: WAR DEPARTMENT

BUREAU \_\_\_\_\_

(PAGE TWO - U62472)

OF OUR TRANSMISSION OF THE ANALYSIS PD FOR EXAMINATION OF ANALYSIS  
 SEE  
 EE PAGE FIVE EIGHT DIGEST BRITISH CODES PD PREBARATIC SAME FORM  
 EXCEPT TIME GROUP ADVANCED TWO FOUR HOURS PD WILL BE PREPARED TO  
 SEND YOU BARATIC S FOR FOUR MAIN MAPS TWO FOUR HOUR PREBARATIC FOR  
 ONE THREE ZERO ZERO ZEBRA CMA OUR EXCHANGE D FORECAST WITH ITALY  
 WHICH IS IN CODE FORM SIMILAR TO THAT HELD BY NICHOLSON CMA  
 DAILY ANALOGUES CMA AREA FORECAST AS YOU REQUEST THEM AND GENERAL  
 SUMMARY OF WEATHER OVER EUROPE PD ADVISE WHEN YOU WISH TO BEGIN  
 TRANSMISSION OF FORECASTS AND WEATHER INFORMATION PD WILL ENDEAVOR  
 TO OBTAIN YOUR REQUESTED SYNOPSIS CMA CLEARANCE FROM BRITISH WILL  
 BE NECESSARY PD HAVE SERIES ONE SEVEN THREE DASH ONE SEVEN SEVEN  
 BEEN RECEIVED PD RECOMMEND THEY BE HELD FOR ANY TRANSMISSIONS OF WHICH  
 ARE NOT ISSUED TO SOVIETS PD CIPHER TO BE USED FOR OUT ENGLAND  
 SIGTOY SERIES ONE SEVEN DASH TWO TWO WHICH YOU HOLD PD MORE TO  
 COME

~~SECRET~~ SECRET

59

0958



STANDARD FORM NO. 14 A  
 APPROVED BY THE PRESIDENT  
 MARCH 10, 1925

*File*  
**TELEGRAM**

OFFICIAL BUSINESS—GOVERNMENT RATES

~~SECRET~~  
 FROM: WAR DEPARTMENT

BUREAU \_\_\_\_\_

C-14

PRIORITY

~~SECRET~~

FILED: 222200

FROM: TEHRAN

TO :

TEH3519

ROUTE FORECAST TEHRAN POLTAVA TWO THREE NAY ZERO SIX DASH  
 ONE SEVEN LCLRPMLCL HIGH SCOTD AS CMA GOING SCOTD TO BRKN  
 AC CMA LWR SCOTD SEC OVER MTS SCOTD THDR SHOWERS FROM  
 BRKN CU AFTR ONE FOUR UCRO ZERO LCL TOP SEC PD CASPIAN AREA  
 HIGH SCOTD TO BRKN CMA LWR SCOTD PD OLD IN EAST HIGH BRKN  
 CMA LWR BRKN CUROST OV TO POLTAVA WITH THDR SHOWERS  
 LLTRPRTN PD VS BY SIX TO ONE TWO LWRNG TO TRO IN PRECIP PD  
 WINDS ALOFT ~~XXXXXX~~ COLON AT EIGHT ZERO ZERO ZERO COLON TWO  
 NINE ZERO AT ONE FOUR TO MAKAHALA CMA TWO FOUR ZERO AT  
 ONE FIVE DASH TWO ZERO INCRSNG TO TWO ZERO DASH TWO SIX  
 LATTER HALF MAKAHALA POLTAVA

CLASSIFICATION CHANGED TO SECRET  
 DDG DIA 22024, 22 MAR 58

*S. Thomas*  
 NAME DATE

~~SECRET~~

2222452

(69)

~~SECRET~~

0959



*Col. Kessler*  
*Castro*

*File*

HQ MAAF  
Weather  
Triplicate

21 May 1944  
VIA  
BRITISH  
CHANNELS

~~SECRET~~

Kessler for Mandell

Letter delivered by Thomas. Short talk with Cullen. Visited Yates but lack complete data on your needs. Will transmit Baratic and forecast from central station here. Queries: Do you receive WTQL? What grid system do you use? We receive all except your 0030Z transmission. Will employ SIGTOY cipher series 29. We classify intercept data here as secret only in order to use data successfully. Please reply to insure establishment of communications. Sending letter also.

Hope duplication of WTQL will not be necessary. Just received your message of May 20. Cannot decipher your data here as we must operate in conjunction with Allies. Query: Do British have SIGTOY or G ciphers? We can load red line circuit with specials and pertinent pilot reports if you request same. Recommend additional operators be requested to enable intercept of blind broadcasts since selection of reports and preparation for retransmission is beyond our capabilities.

CLASSIFICATION CHANGED TO SECRET  
SEC DIR. 5200.9, ET 117 43  
*B.H.* *7/27/79*  
NAME DATE

~~SECRET~~

0960

STANDARD FORM NO. 14 A  
APPROVED BY THE PRESIDENT  
MARCH 10, 1925

*Jill*  
**TELEGRAM**  
OFFICIAL BUSINESS—GOVERNMENT RATES

~~SECRET~~  
FROM: WAR DEPARTMENT

BUREAU \_\_\_\_\_

*20 May 44*

FROM: TEHRAN FLD 201450Z ROUTINE

TO : POLTAVA

TEH 3442

PUSHED ON BY US TO POLTAVA ALL THE WILCOX NINE SIX CHARLIE  
TRANSMITTER AND ASSOCIATED EQUIPMENT WHICH YOU SECURED THROUGH  
COL DEIGERT IN CAIRO WITH EXCEPTION OF ONE SMALL GENERATOR PD  
TO DEANE INFO KESSLER TOP SEC FROM CONNOLLY THIS REMAINING  
ITEM IS EXPECTED TO DEPART SOON PD QUOTE ATTENTION COL KNOLL  
AAC STATION FIVE FIVE NINE UNQUOTE WAS MARKING ON EQUIPMENT  
PD IN CASE NECESSARY FOR USE IN SHUTTLE SERVICE MOSCOW POLTAVA  
WE ARE ARRANGING USE OF C EIGHT SEVENS AND THEY MAY BE USED  
TO MOVE YOUR STUFF TO DESTINATION

**ROUTINE**

CLASSIFICATION CHANGED TO SECRET  
DOD DIR 8700.9, 27 SEP 58  
*Schme* *Jan 59*  
NAME DATE

*20 2110 Z*

C-9

~~SECRET~~  
R 30  
7CP  
MAY 22 1944  
*21082*  
*44*

~~SECRET~~

0961

STANDARD FORM NO. 14A  
 APPROVED BY THE PRESIDENT  
 MARCH 10, 1925

~~TOP SECRET~~  
**TELEGRAM**

OFFICIAL BUSINESS—GOVERNMENT RATES

20 MAY 1950  
 FROM: WAR DEPARTMENT

BUREAU

File 20581

TO: COL KESSLER

FROM: TEHRAN FLD 201300 PRIORITY

TEH3486

QOSSIZLE TO BE USED ON MOSCOW SHUTTLE ZNOXTZC SEVEN NBR  
 ZERO FIVE FIVE ONE IF YOU DESIRE TO MOVE GEN DEANES  
 EPNIPMEVT PAREN TO KESSLER FROM JOHNSON TOPSECRET PAREN  
 MUST BE IN TEHRAN ON TWO FIVE PD ZERO SIX TWO TWO OCH  
 TWK FIVE PC FOR THE BALANCE OF THE MISSION IS ZERO SIX TWO  
 TWS OUT OF SERVICE

MSG. BADLY GARBLED - WILL ASK FOR

REPEAT IF DESIRED.

20 1333Z

C-6

~~TOP SECRET~~

CLASSIFIED  
 BY: CFC  
 DATE: 20 May 1980  
 13304

STANDARD FORM NO. 14-A  
 APPROVED BY THE PRESIDENT  
 MARCH 10, 1926

*JH*  
**TELEGRAM**  
 OFFICIAL BUSINESS—GOVERNMENT RATES

~~SECRET~~  
 FROM: V R DEPARTMENT

BUREAU \_\_\_\_\_

FROM: SPAATZ - JBPD  
 TO : KESSLER  
U62369

~~SECRET~~  
 PRIORITY  
 FILED 201025Z

*20 May 44*

CARRIED OUT FOLLOWING ACTION ON DOCUMENTS AND DATA REFERRED TO  
 IN OUR UNCLE ONE TWO SIX FOUR THREE APRIL SEVENTEEN PD LT  
 RICHARD HILL LEFT UNITED KINGDOM ON APRIL TWO SEVEN ACCOMPANY-  
 ING COL LOVE BAKER HICKAM TRAVELING ON AIR PRIORITY ONE BOUND  
 FOR POLTAVA PD TOPSEC TO KESSLER SIGNED SPAATZ UNCLE SIX TWO  
 THREE SIX NINE REUR ROGER ONE ONE FOUR MAY EIGHTEEN PD HE IS  
 KNOWN TO HAVE BEEN IN CAIRO ON MAY TWELVE PD HE IS CARRYING PACKAGE  
 ADDRESSED TO COMMANDING OFFICER DETACHMENT FIVE ATTN MAJOR  
 SPAULDING THROUGH UNITED STATES MILITARY MISSION MOSCO<sup>W</sup> PD THIS  
 PACKAGE CONTAINS DOG SLANT FOX VERIFICATION TABLES FOR MONTH  
 OF MAY CMA CURRENT EIGHTH AIR FORCE PROCEDURES AND SIGNAL  
 OPERATIONS INSTRUCTIONS INCLUDING SPLASHER BEACON SCHEDULE FOR  
 MAY AND SQUADRON CODE LETTER ASSIGNMENTS FOR EIGHTH AIR FORCE  
 BOBBARDMENT SQUADRONS PD IT IS SUGGESTED THAT LT HILL BE CON-  
 TACTED IMMEDIATELY UPON HIS ARRIVAL AND INSTRUCTED TO DELIVER  
 PACKAGE DIRECT TO YOU WITHOUT GOING THROUGH MOSCOW PD OTHER  
 PUBLICATIONS WERE SENT IN SEVEN POUCHES ENTRUSTED TO LT EUGENE  
 ROGER ZEVIM WHO LEFT UNITED KINGDOM MAY NINE BY AIR WITH GROUP  
 OF INTERPRETERS PD THESE POUCHES CONTAIN BOMBER CODE AND DOG

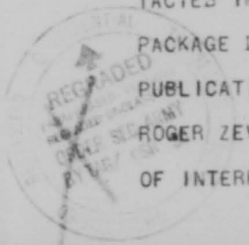

~~SECRET~~  
*46*

0963

STANDARD FORM NO. 14 A  
APPROVED BY THE PRESIDENT  
MARCH 18, 1924

*File*  
**TELEGRAM**

OFFICIAL BUSINESS—GOVERNMENT RATES

-(PAGE TWO - JBPD 201025Z - U62369)

~~SECRET~~  
FROM: V R DEPARTMENT

BUREAU: \_\_\_\_\_

*Priority*

SLANT FOX VERIFICATION SIGNALS FOR USE DURING JUNE AND CALL  
SIGNS FOR EIGHTH AIR FORCE BOMBERS PD HE IS ALSO CARRYING  
CRYPTOGRAPHIC EQUIPMENT FOR ENCODING MESSAGES SENT ON POINT  
TO POINT NETWORK PD LATTER INCLUDES ONE TIME PADS NECESSARY  
FOR DECODING MESSAGES CONTAINING COLORS OF THE DAY PD SPECIAL  
AIR GROUND CODE AND EXTRA CRYSTALS FOR FIFTEENTH AIR FORCE  
AIRCRAFT HAVE JUST BEEN RECEIVED AT THIS HQ AND ARE BEING  
FORWARDED TO YOU AT ONCE

*24*  
*16*  
~~SECRET~~  
SECRET

0964

S. C. Form No. 7

*JL* ~~SECRET~~ **SECRET**  
Signal Corps, United States Army

Received at

**ROUTINE**

FROM: WIDEWING FILED 190921Z

20 MAY 1944

19

TO: EAKER INFO: KESSLER REF: DEANE INFO: ARNOLD

CLASSIFICATION CHANGED TO SECRET  
DOD DIR. 5200.9, 22 SEP 55

FROM: KNERR SIGNED SPAATZ

E. H. HARRIS Jan 17  
NAME DATE

DESIGNED IN ORDER TO EXPEDITE INITIAL SHIPMENT PAREN EAKER  
INFO ARNOLD INFO KESSLER FROM KNERR TOP SECRET SIGNED SPAATZ  
REFERENCE DEANE ONE FIVE FOUR PAREN OF SUPPLIES FOR FIVE ZERO  
TO SEVEN ZERO PETER FIVE ONE AIRCRAFT CAN YOU INITIATE THIS  
SHIPMENT USING ATC FACILITIES QUERY ADDITION OF ANY SHORTAGES  
SO THAT THESE MAY BE FILLED FROM STOCKS IN U K PD RECOMMEND THAT  
INITIAL SHIPMENT BE BASED ON THREE ZERO DAY LEVEN CMA COMBAT  
TECHNICAL SUPPLIES PD THERE ARE SUFFICIENT ~~XXX~~ POL CMA HOUSE-  
KEEPING CMA MEDICAL CMA ORDNANCE AND OTHER SUPPLIES ALREADY  
AVAILABLE AT RUSSIAN BASES PD SUPPLY ITEMS COMMON TO BAKER ONE  
SEVEN AND PETER FIVE ONE AIRCRAFT AND THOSE RECENT EXPERIENCE  
HAS SHOWN LOW OR ZERO CONSUMPTION SHOULD NOT BE INCLUDED PD  
MAINTENANCE PERSONNEL SENT TO RUSSIA FROM U K ARE SPECIALISTS  
~~XXXXXXXXXX~~ FOR BAKER ONE SEVEN ON B K WITH FEW ADDITIONAL

~~SECRET~~ **SECRET**

45 pages

MORE

0965



~~SECRET~~  
PAGE 2

SECRET

ROUTINE

PERSONNEL TO HANDLE PETER THREE EIGHT PHLTR RECONNIASSANCE  
AIRCRAFT PD STRONGLY RECOMMEND THAT YOU ARRANGE AIR SHIPMENT MINIMUM  
NUMBER ADDITIONAL PERSONNEL TO HANDLE PETER FIVE ONE MAINTENANCE  
REQUIREMENTS PD THERE IS NO NECESSITY FOR SENDING ANY OTHER  
PERSONNEL THAN CREW CHIEFS PLUS FEW ARMAMENT SPECIALISTS PD HOWEVER  
TOTAL PERSONNEL YOU SEND MUST NOT EXCEED THREE ZERO RPT THREE ZERO  
PD ADVISE ACTION TAKEN ON PERSONNEL AND MATERIAL

CRYPTOGRAPHED

BY Growing Hester  
DATE May 20 '44  
TIME 1128Z

20 MAY 1944

C-5  
20/1136

~~SECRET~~

0966



S. C. Form No. 7

~~SECRET~~  
Signal Corps, United States Army

Received at

20 MAY 1944

U. S. GOVERNMENT PRINTING OFFICE 7-5087

TO:

FROM: TEHERAN

TEH3472 FLD 191435Z

**PRIORITY**

19

PRIORITY PRD PETER ONE FOUR TWO EIGHT EIGHT TO KESSLER FROM  
 CONNOLLY TOP SECRET PRD MESSAGE BEGINS HERE E PRD FOLLOWING  
 PARAPHRASE OF MESSAGE RECEIVED THIS DATE QUOTE TO KESSLER  
 REPEAT ED TO CONNOLLY PRD CITE UNCLE DASH SIX TWO THREE ZERO  
 ZERO FOUR ROGER OF TWELFTH DAY MAY PRD LEFT ETEL<sup>NG</sup> AND VIA ABLE  
 TARE CHARLIE ON MAY SEVENTH CAPTAIN EDWARD<sup>J</sup> S STIMPSON OBOE  
 TWO EIGHT FOUR SEVEN NINE NINE MIKE CHARLIE PRD HIS DESTINATION  
 IS TEHERAN PRD HE IS A FULLY QUALIFIED SURGEON AND IS A REPLACEMENT~~MENT~~  
 FOR ROUNDTREE PRD SPAATZ UNQUOTE PRD CAPTAIN STIMPSON HAS  
 ARRIVED TEHERAN PRD WILL FORBARD<sup>W H</sup> INSIGH GEAR

CLASSIFICATION CHANGED TO SECRET  
 (REF. DIR. 5800.2, 22 APR 43)  
 Ed  
 DATE 2 Jun 47

~~SECRET~~  
 REF 38

CR  
 JAH  
 DATE 20  
 TIME 0724Z

200725

~~SECRET~~

44

0967

U. S. Form No. 7

~~SECRET~~  
Signal Corps, United States Army

Received at

**ROUTINE**

FROM: TEHERAN FLD 191300Z NR6  
TO:

TEH3463

ARRANGEMENTS ARE BEING MADE FOR SHUTTLE TRIP OF HAREDMAN CHARLIE  
DASH EIGHTY SEVEN FROM POLTAVA TO MOSCOW TO TRANSPORT SIGNAL  
EQUIPMENT CONSIGNED TO DEANE PRD SUGGEST YOU SEGREGATE ALL SUCH  
CARGO NOW ON HAND POLTAVA PRD TO KESSYER FROM MARTIN SIANE  
CONNALLY TOP SEC PRD NEW SUBJECT RADIO FROM WASHINGTON DATED  
MAY EIGHTEENTH ADVISES RUSSIAN ENGLISH METEOROLOGICAL DICTION-  
ARIES BEING FORWARDED VIA AIR MAIL PRD NEW SUBJECT DEANE IS  
BEING REQUESTED TO OBTAIN AUTHORITY FOR THE CONTINUED USE OF  
GROUP VISAS APPROVED BY LOCAL RUSSIAN REPRESENTATIVES TEHERAN IS  
TERMINAL FRANTIC FORCE OF ONE TWO ZERO ZERO HAS ENTERED RUSSIA  
PRD WE ANTICIPATE NECESSARY FOR OCCASIONAL TRIPS OF PGC PERSONNEL  
TO AND FROM TEHERAN AS WELL AS SPECIAL INDIVIDUALS TRAVELING TO  
POLTAVA IN CONNECTION WITH YOUR OPERATIONS PRD OBTAINING REGULAR  
VISAS WILL CAUSE UNDUPLICATE DELAY AND MAY HINDER YOUR OPERATIONS  
PRD THEREFORE WE COMMAND YOU DO DO ANYTHING POSSIBLE TO ASSIST

~~SECRET~~

20:0600  
APR 30

C.7

0968

~~SECRET~~

IN OBTAINING THIS AUTHORITY FOR ONE <sup>Z</sup>ZERO <sup>I</sup>ZERO ADDITIONAL ENTRIES  
 BE OBTAINED PRD THIS IN ACTION O THE ONE ZERO ZERO <sup>R</sup>REQUIBED TO  
 GET THE <sup>A</sup>BKLANCE OF YOUR PERMANENT FORCE <sup>M N</sup>ICTO <sup>N</sup>RUSSIA PRD NEW SUB-  
 JECT RECOMMEND YOU INITIATE ACTION TO <sup>OB</sup>AXTAIN AUTHORITY FOR PHE  
 CONTINUED USE OF REGULARLY SCHEDULED ABLE TARE CHARLIE FLIGHT B  
 FROM TEHERAN TO <sup>L</sup>POWTAVA PD DO NOT FEEL THE PRESEUTLY SCHEDULED  
 CHARLIE DASH FOUR SEVEN FLIGHT <sup>E</sup>QACH WEEK UNDER RUSSIAN CONTROS  
 WILL BE ADEBATE <sup>Q F</sup>FOR YOUR NEEDS NOR DEPENDABLE SINCE RUSSIANS  
 ARE <sup>R</sup>LELUCTANT <sup>T</sup>XO FLY IN <sup>HEP</sup>WEATVSA THAT OUR <sup>I T</sup>PQLOUS FEEL SAFE PRD  
 IF IT IS POSSIBLE TO OBTAKN SUCH AUTHORITY THIS HEADQUARTERS  
 FEELS CERTAIN YOU WILL FIND IT TO YOUR ADVANTAGE PRD THIS INFO  
<sup>E</sup>BGING FOR WARDED TO DEANE ALSO

CRYPTOGRAPHED

BY WJA-GFCDATE 20TIME 0552Z~~SECRET~~

13

0969

S. C. Form No. 7

~~SECRET~~  
Signal Corps, United States Army

Received at

TO KESSLER  
FROM TEHERAN  
TEH3442

CLASSIFICATION CHANGED TO SECRET  
RFD 01K 20009, 27 SEP 58

NAME: [Signature]  
DATE: 10/1/58

*File* *20 MAY 1944* *File*  
*20-5-44* *Ally* *C-3*

AWAITING NOW AT TEHERAN FOR PERMISSION AND VISAS TO ENTER RUSSIAN IS ONE BAKER DASH ONE SEVEN GEORGE NBR FOUR TWO DASH ONE ZERO SEVEN ONE SIX TWO PD TO KESSLER FROM MARTIN SGND CONNOLL PD TOP SECRET PD NEW SUBJECT COL HICKAM NOW IN TEHERAN WILL DEPART FOR POLTAVA WAY ONE NINE PD NEW SUBJECT RUSSIAN CONSUL TEHERAN ADVISE HE HAS APPROVED VISAS FOR ONE TWO ZERO ZERO ENTRIES AND CAN APPROVE NO MORE PD SOME OF THESE WERE CANCELLED PRIOR TO ENTRY OF INDIVIDUALS PD OUR RECORDS SHOW A TOTAL OF ONE ONE EIGHT SIX ARE NOW ASSIGNED TO THE PROJECT PD OF THESE ONE ZERO THREE FIVE ARE IN RUSSIA CMA HERE AT TEHERAN ARE FOUR SEVEN CMATWO ARE SICK IN CAIRO CMA AND TWO SICK AT HAIFA PD OF THOSE ON HAND IN TEHERAN FIVE ONE HAVE VISAS APPROVED PD BALANCE ON HAND OF NINE SIX PLUS FOUR DUE TO ARRIVE MAKE TOTAL OF ONE ZERO ZERO MORE VISAS REQUIRED PD REQUEST YOU OBTAIN OFFICIAL REPORT FROM RUSSIAN AUTHORITIES POLTAVA AS TO EXACT NBR ENTRIES ON THEIR RECORDS AND ADVISE BY RADIO PD ALSO HAVE RUSSIANS POLTAVA REPORT THIS FIGURE TO THEIR AUTHORITIES MOSCOW AND TEHERAN PD

~~SECRET~~  
10/1/58

20 MAY 1944  
19  
C-3

42  
~~SECRET~~

0970

S. C. Form No. 7

~~SECRET~~  
Signal Corps, United States Army

Received at

U. S. GOVERNMENT PRINTING OFFICE 7-5021

19

TEH3442 (PAGE TWO)

RUSSIANS CONSULT TEHERAN MUST BE INSTRUCTED TO CREDIT HIS  
RECORDS FOR NUMBER DELATED FROM APPROVED VISXS OR ADDITIONAL VISA  
AUTHORITY OBTAINED BY RUSSIAN CONSUL PD ODEANE HAS BEEN REQUESTED  
TO OBTAIN AUTHORITY FOR ONE ONE ZERO MORE VISAS PD IF YOU CAN  
ASSIST IN ANY WAY DO SO PLEASE

X  
~~SECRET~~  
SECRET

C-3

190942

12

0971

S. G. Form No. 7

*file*

~~SECRET~~  
Signal Corps, United States Army

Received at

U. S. GOVERNMENT PRINTING OFFICE 1-5481

FROM: TEHRAN FLD 181451Z  
TO: COL KESSLER, HQ MIS 11

19

TEH3443  
CULLEM

PRELEY REQUESTED PUBLICATIONS SUCH AS TIME MAGAZINE CMA NE SHEEK  
R  
CMA LIFE CMA READERS DIGEST CMA NEW YORK TIMES WEEKLY EDITION  
A  
CMA AND OTHERS BEFORWARDED TO YOU PD TO KESSLER SIGNED CONNOLLY PD  
SINCE RUSSIAN S HAVE DIFFERENT CENSORSHIP REGULATIONS SUGGEST  
YOU TAKE NECESSARY ACTION TO OBTAIN PERMISSION FOR ENTRY OF  
DESINED PUBLICATIONS AND NOTIFY THIS HEADQUARTERS THAT AUTHORITY  
FOR THEIR ENTRY HAS BEEN OBTAINED PD UPON RECEIPT OF THIS  
AUTHORITY AND YOUR REQUISITION WE WILL TAKE ACTION TO FORWARD  
MATERIALS TO YOU

~~SECRET~~  
CLASSIFICATION  
GROUP 1  
EXCLUDED FROM AUTOMATIC  
DOWNGRADING AND  
DECLASSIFICATION

CLASSIFICATION CHANGED TO SECRET  
DDG DA. 8200A, 27 SEP 55  
2/25/56  
10/21/55

DATE: *Jan 18*  
TIME: *2316Z*

~~SECRET~~

*182220Z*  
*155*

0972

- ✓ 10. Handling crates + boxes.  
(paper to be reviewed)
- ✓ 11. Stripps as Special Service Officer
- ✓ 12. Keep clean of girls (order)
- ✓ 13. Trip accident at Mirgorod.
- ✓ 14. Russian restaurants at each town.

1. Use of hospital? See Joe.

2. Cemetery. See James.

3. Progress photos.

4. Camp places.

5. Wood gates at Palans.  
(bonds)

at other station

6. Bond requirements for each  
Station cabinet!

7. Mattings at Pryatun.

⑧ Send to Prig + Prig (req)

✓ 9. Copies in Pryatun + Mirgorod.  
(23/00) special passes for personal  
designated by me.

Blackout

0973



*End Kessler Copy*  
*① CW3*  
*② adj. file*

INCOMING MESSAGE  
U S MILMIS, MOSCOW

From : Persian Gulf Command, Teheran Number : P-1424  
Subject : Incendiary bombs for FRANTIC Date : 18 May 1944  
Distribution: Triplicate Received: 05/19/0700Z  
Decoded : MAB Security: ~~SECRET~~ SECRET  
Typed : White

~~SECRET~~  
SECRET

CG for Kessler from Graham TOPSEC

Answering your letter subject "Incendiary Bomb Shipments" dated 16 May. London states there is no shipment of incendiary bombs from U.K. to PGC for you.

CONNOLLY.

CLASSIFICATION CHANGED TO SECRET  
BY *E. Th...* 3 JUN 47  
DATE

~~SECRET~~  
SECRET  
R 30

~~SECRET~~  
SECRET

39

*Col. K...*  
*(M)*

INCOMING MESSAGE  
U S MILMIS, MOSCOW

From : Milattache, Amembassy, London      Number : 12959  
Subject : Anderson's Schedule                      Date : 12 May 1944  
Distribution: Triplicate                              Received: 05/13/0931Z  
Decoded : BR    Security: ~~SECRET~~  
Typed : White

~~SECRET~~  
SECRET

URGENT

To Deane information repeated AGWAR action from Spatz.

Answering your 35359.

Tentative schedule for Anderson, expect to depart for U. K. 13 May  
with stop over at Eaker Headquarters. Anderson will send you detailed  
itinerary.

PEABODY.

CLASSIFICATION CHANGED TO UNCLASSIFIED  
BY DMR. SPGCA, AT SEP 88  
*E.H.*      *3-10-79*  
DATE      DATE

~~SECRET~~  
SECRET

*25*  
*1*

Milattache, Amembassy, London

12937

Whereabouts of Colonel Hickam

11 May 1944

Triplicate

05/12/14422

~~SECRET~~

BR

White

~~SECRET~~

To Deane for Kessler from Knerr and Spaatz.

Reur 139.

No information available here on whereabouts of Colonel Laurence  
B. Hickam. Hickam departed U.K. via ATC 27 April. ATC checking their  
stations to determine where he is. Will advise you when further in-  
formation is available.

PEARODY.

CLASSIFICATION AUTHORITY  
DATE FOR REVIEW BY  
*S. H.* *3/11/53*  
BY DATE

~~SECURITY INFORMATION  
EXCLUDED FROM ALLY  
BY DATE 5 30~~

~~SECRET~~

0976

*File*

Milattache, Amembassy, London

12884

Weather ciphers for FRANTIC

5 May 1944

Triplicate

05/06/0730Z

~~SECRET~~

BR

White

~~SECRET~~  
**SECRET**

For Mundell repeated to Arnold for Bassett from Yates.

Addressed to Staff Weather Office Detachment 5 U. S. Strategic Air Forces in Europe, Washington sent ciphers 3 May to your headquarters. This is a paraphrase of cable U61732 sent to Connolly. Through courier diplomatic to Moscow U. S. WILMISSION, Moscow believed best method of delivery. Please advise if method not most practical and secure.

PEABODY.

~~SECRET~~  
SEC ARMY  
30 1

CLASSIFICATION CHANGED TO SECRET  
DDO DNR 8200X, 22 SEP 84  
*Edwards* *Jan 79*  
NAME DATE

~~SECRET~~  
**SECRET**

65

0977

*File*  
TRUE TEXT

INCOMING MESSAGE  
U S MILITARY, MOSCOW

From: Milantache, Ambassador, London Number: 17851  
 Subject: Weather Date: 5 May 44  
 Distribution: Triplicate Received: 05060724Z  
 Action to: Security: ~~SECRET~~  
 Decoded: SP/IAS Typed: Plain

~~SECRET~~  
**SECRET**

22 For Daniels repeated Arnold Cross Yates.

Cite our 18774.

Dispatched from Washington May 3 SINTOX Ciphers series 17 through 34. These ciphers for redline weather exchange. Series 17 through 22 marked out England, series 23 through 28 marked out Italy, series 29 through 34 marked out Russia. Replacements will be forwarded when available, production presently in progress.

PEACOCK

X

CLASSIFIED BY [unclear]  
 Edms 3455  
 NAME DATE

~~SECRET~~  
 R 30

66

~~SECRET~~  
**SECRET**

0978

**SECRET**

INCOMING MESSAGE

TRUE TEXT

From: Millettche, Amembassy, London

Number 12049

Subject: Anderson's proposed trip

Date: 5 May 1944

To Desne repeated Arnold from Anderson ~~██████████~~

Definitely coming. Expect arrive Teheran May 8 with party of twelve in B-17 G number 42-102642 c/n 12058. Request group entry and exit visas be obtained for immediate continuance of flight to Moscow and clearance, Russian navigator and radio operator for airplane be arranged. Party by name rank serial number place and date of birth occupation:

F. L. Anderson, Major General, O-17175, Kingston, New York,  
4 October 1905, Deputy CG USSTAF.

E. P. Curtis, Brigadier General, O-140277, Rochester, New York,  
14 January 1897, Chief of Staff USSTAF.

F. J. Sutterlin, Colonel, O-21633, Frankfort, Kentucky, 24 Sep-  
tember 1911.

L. P. Weicker, Colonel, O-908797, Stamford, Conn., 14 October  
1903, Staff.

Elliot Roosevelt, Colonel, O-396475, New York, New York, 23  
September 1910, Staff.

J. A. Thomas, Colonel, O-21569, Virginia, 17 March 1909, Staff.

J. A. Leuro, Captain, O-389236, Brooklyn, New York, 26 September  
1918, Pilot.

INFORMATION CONTAINED  
 HEREIN IS UNCLASSIFIED  
 DATE 11/17/01 BY 3025  
 [Signature]

~~SECRET~~

~~SECRET~~  
 DECLASSIFIED ON  
 11/17/01  
 BY 3025

0979

~~SECRET~~  
SECRET

D. F. Bertholf, Captain, O-662276, Denver, Colo., 24 November  
1920, Navigator.

J. C. Bagone, Captain, O-341583, Philadelphia, Penna., 18 July  
1916, Navigator.

M. H. Kovel, Lieutenant, O-799771, Clifton, New Jersey, 30 October  
1917, Co-Pilot.

G. C. Layne, M/Sgt, 3504070, Biloxi, Miss., 14 September 1919,  
Engineer.

J. D. Setser, T/Sgt, 5825114, Sulphur Springs, Ark., 15 January  
1921, Radio Operator.

Flight plan will follow immediately. Imperative trip not be  
delayed Teheran account entrance arrangements. Am also sending above  
to Knoll at Teheran to save time on communications. Request you have  
Kessler meet me Moscow Monday night.

FEARODY

~~SECRET~~  
SECRET

0 9 8 0



INCOMING MESSAGE

~~SECRET~~TRUE TEXT

From: Milletteche, Embassy, London

Number: 12870

Subject: Anderson's Trip

Date: 5 May 1944

URGENT

Desne from Anderson and Speaks repeated information Arnold [redacted]  
 Your S 245. Absolutely essential this trip be made very quickly.  
 We are departing in accordance flight plan furnished you our 12869 as  
 Ambassador Harriman advised leave even if final confirmation had not  
 been received. Hope delay Teheran will not be over three hours in order  
 expedite travel and have freedom of action desire use own airplane with  
 Russian navigator and radio operator procured Teheran. Also recent  
 model airplane and arrangements in airplane will be of interest. We  
 can land any place C-47 can land. Not necessary but desirable land  
 all three airdromes. We are also bringing you many documents and  
 baggage which may cause inconvenience and result in delay if necessary  
 change airplanes at Teheran. Appreciate very much your interest and  
 help.

FEABODY

CLASSIFICATION CHANGED TO SECRET  
 500-DM-12008, 22 DEC 52S. [redacted] 12-17  
 NAME DATE~~SECRET~~~~SECRET~~  
 H 30

0981

## INCOMING MESSAGE

U S MILMIS, MOSCOW

From : Persian Gulf Command                      Number : Px-13200  
 Subject : FRANTIC Status Report                      Date : 17 April 1944  
 Distribution:    Received: 04/18/0845Z  
 Action to :    Security: ~~SECRET~~ SECRET  
 Decoded :    Typed : Flavin

To Deane for Kessler information Spaatz for Knerr from Knoll signed  
 Connolly.

Following is status report as of 09:00 hours today: Third echelon  
 12 nurses, 229 enlisted men, 36 officers; crew for mission 18 enlisted  
 men 28 officers.

New subject: A-2 officer, Major A. V. de Sakhnoffsky has reported.  
 Priority for him requested. He states he has full information for  
 briefing Russian pilots for airplane identification. Spaatz has issued  
 him directive regarding his particular function. After gathering certain  
 information, he will return to brief American crews in the United Kingdom.

PARAPHRASE

CLASSIFICATION CHANGED TO SECRET  
 DOD DIR 5800.9, 21 APR 58  
 [Signature] [Signature]  
 NAME DATE

Initials:

0982

NO. USSAFS  
INCOMING MESSAGE

~~SECRET~~

Action Copy to: Dir Weather  
Info Copies to: Dir Opns  
D/C Ops (2)

Priority *File*

Secret

Reference no. and Date F-203

16 Feb 41

From WAR  
To AWW

To : Spaatz  
Per : Yates  
Ass to Mundell  
From : Bassett  
Signed : Arnold  
Reurad : W-10890/4487

Excellent linguistic ability

2nd Lt Leo J Zainkowski  
2nd Lt Stanley J. Szevesak (11)  
Sgt Albert E. Barkenbilt  
S/Sgt Arnold Malin  
Cpl Andrew P. Rowdill

Fair linguistic ability

2nd Lt. John J Beckish (11)      S/Sgt Nicholas Fusack  
2nd Lt Leo Neuschwander      Cpl Hanson S. Powsner  
2nd Lt. Bill Obradorich (10)    Sgt Joseph Maurin  
2nd Lt. Michael J Graycar      Sgt Don A. Sanchez  
2nd Lt. Samuel Koziar          Cpl John W. Durko  
2nd Lt. Basil B. Dolinsky      Cpl John Kalasza  
2nd Lt. Lewis F. Sokol

Poor linguistic ability

2nd Lt Ralph E. McCormack  
2nd Lt Charles F. Alex  
2nd Lt Carl D. Mayes  
2nd Lt John P Kotlewskk

Assigned to 10th Mes Reg is Lt. Obradorich., to 11th  
is Lts Beckish Szevesak and McCormack and to 18th is Lt  
Sokol. All others in US. Sanchez born in Bulgaria, Malin  
in USSR others in US.

CLASSIFICATION CHANGED TO SECRET  
DATE 01 JUN 88  
3 James June 88  
DATE

~~SECRET~~



0983

Hq. USSAF  
INCOMING MESSAGE

~~SECRET~~

Act: Copy to Weather  
Info Copies to: Dir Cps  
S/C Cps (2)  
C/S

Routine

Secret

Reference No. and Date F-240

14 Feb 44

From WAR

To AWW

To : Yates  
For : Mundell  
From : Bassett  
Signed : Arnold

Already in effect is limited weather exchange between London and Moscow. Synoptic Soviet data originates in Tiflis and Moscow in one way pad cyphers of British origin. Our RCO Twelfth Weather Region and AAF in Teheran have indicated to local British representatives that they desire this data. They need the one way pad to receive it. If Soviets agree to USAAF holding these pads British indicate they will not object. Soviet broadcasts can be received but must have cypher in order to use. Apparently no obstacle in communications. Further investigation of exchange suggested, also effort to obtain ~~the~~ these pads for our units at Roggic and Teheran. British will furnish pads if approval is obtained. Acknowledge receipt of this message.

CLASSIFICATION CHANGED TO SECRET  
SEC. 1.4, 1.5, 1.6, 1.7, 1.8, 1.9, 2.1, 2.2, 2.3, 2.4, 2.5, 2.6, 2.7, 2.8, 2.9, 3.1, 3.2, 3.3, 3.4, 3.5, 3.6, 3.7, 3.8, 3.9, 4.1, 4.2, 4.3, 4.4, 4.5, 4.6, 4.7, 4.8, 4.9, 5.1, 5.2, 5.3, 5.4, 5.5, 5.6, 5.7, 5.8, 5.9, 6.1, 6.2, 6.3, 6.4, 6.5, 6.6, 6.7, 6.8, 6.9, 7.1, 7.2, 7.3, 7.4, 7.5, 7.6, 7.7, 7.8, 7.9, 8.1, 8.2, 8.3, 8.4, 8.5, 8.6, 8.7, 8.8, 8.9, 9.1, 9.2, 9.3, 9.4, 9.5, 9.6, 9.7, 9.8, 9.9, 10.1, 10.2, 10.3, 10.4, 10.5, 10.6, 10.7, 10.8, 10.9, 11.1, 11.2, 11.3, 11.4, 11.5, 11.6, 11.7, 11.8, 11.9, 12.1, 12.2, 12.3, 12.4, 12.5, 12.6, 12.7, 12.8, 12.9, 13.1, 13.2, 13.3, 13.4, 13.5, 13.6, 13.7, 13.8, 13.9, 14.1, 14.2, 14.3, 14.4, 14.5, 14.6, 14.7, 14.8, 14.9, 15.1, 15.2, 15.3, 15.4, 15.5, 15.6, 15.7, 15.8, 15.9, 16.1, 16.2, 16.3, 16.4, 16.5, 16.6, 16.7, 16.8, 16.9, 17.1, 17.2, 17.3, 17.4, 17.5, 17.6, 17.7, 17.8, 17.9, 18.1, 18.2, 18.3, 18.4, 18.5, 18.6, 18.7, 18.8, 18.9, 19.1, 19.2, 19.3, 19.4, 19.5, 19.6, 19.7, 19.8, 19.9, 20.1, 20.2, 20.3, 20.4, 20.5, 20.6, 20.7, 20.8, 20.9, 21.1, 21.2, 21.3, 21.4, 21.5, 21.6, 21.7, 21.8, 21.9, 22.1, 22.2, 22.3, 22.4, 22.5, 22.6, 22.7, 22.8, 22.9, 23.1, 23.2, 23.3, 23.4, 23.5, 23.6, 23.7, 23.8, 23.9, 24.1, 24.2, 24.3, 24.4, 24.5, 24.6, 24.7, 24.8, 24.9, 25.1, 25.2, 25.3, 25.4, 25.5, 25.6, 25.7, 25.8, 25.9, 26.1, 26.2, 26.3, 26.4, 26.5, 26.6, 26.7, 26.8, 26.9, 27.1, 27.2, 27.3, 27.4, 27.5, 27.6, 27.7, 27.8, 27.9, 28.1, 28.2, 28.3, 28.4, 28.5, 28.6, 28.7, 28.8, 28.9, 29.1, 29.2, 29.3, 29.4, 29.5, 29.6, 29.7, 29.8, 29.9, 30.1, 30.2, 30.3, 30.4, 30.5, 30.6, 30.7, 30.8, 30.9, 31.1, 31.2, 31.3, 31.4, 31.5, 31.6, 31.7, 31.8, 31.9, 32.1, 32.2, 32.3, 32.4, 32.5, 32.6, 32.7, 32.8, 32.9, 33.1, 33.2, 33.3, 33.4, 33.5, 33.6, 33.7, 33.8, 33.9, 34.1, 34.2, 34.3, 34.4, 34.5, 34.6, 34.7, 34.8, 34.9, 35.1, 35.2, 35.3, 35.4, 35.5, 35.6, 35.7, 35.8, 35.9, 36.1, 36.2, 36.3, 36.4, 36.5, 36.6, 36.7, 36.8, 36.9, 37.1, 37.2, 37.3, 37.4, 37.5, 37.6, 37.7, 37.8, 37.9, 38.1, 38.2, 38.3, 38.4, 38.5, 38.6, 38.7, 38.8, 38.9, 39.1, 39.2, 39.3, 39.4, 39.5, 39.6, 39.7, 39.8, 39.9, 40.1, 40.2, 40.3, 40.4, 40.5, 40.6, 40.7, 40.8, 40.9, 41.1, 41.2, 41.3, 41.4, 41.5, 41.6, 41.7, 41.8, 41.9, 42.1, 42.2, 42.3, 42.4, 42.5, 42.6, 42.7, 42.8, 42.9, 43.1, 43.2, 43.3, 43.4, 43.5, 43.6, 43.7, 43.8, 43.9, 44.1, 44.2, 44.3, 44.4, 44.5, 44.6, 44.7, 44.8, 44.9, 45.1, 45.2, 45.3, 45.4, 45.5, 45.6, 45.7, 45.8, 45.9, 46.1, 46.2, 46.3, 46.4, 46.5, 46.6, 46.7, 46.8, 46.9, 47.1, 47.2, 47.3, 47.4, 47.5, 47.6, 47.7, 47.8, 47.9, 48.1, 48.2, 48.3, 48.4, 48.5, 48.6, 48.7, 48.8, 48.9, 49.1, 49.2, 49.3, 49.4, 49.5, 49.6, 49.7, 49.8, 49.9, 50.1, 50.2, 50.3, 50.4, 50.5, 50.6, 50.7, 50.8, 50.9, 51.1, 51.2, 51.3, 51.4, 51.5, 51.6, 51.7, 51.8, 51.9, 52.1, 52.2, 52.3, 52.4, 52.5, 52.6, 52.7, 52.8, 52.9, 53.1, 53.2, 53.3, 53.4, 53.5, 53.6, 53.7, 53.8, 53.9, 54.1, 54.2, 54.3, 54.4, 54.5, 54.6, 54.7, 54.8, 54.9, 55.1, 55.2, 55.3, 55.4, 55.5, 55.6, 55.7, 55.8, 55.9, 56.1, 56.2, 56.3, 56.4, 56.5, 56.6, 56.7, 56.8, 56.9, 57.1, 57.2, 57.3, 57.4, 57.5, 57.6, 57.7, 57.8, 57.9, 58.1, 58.2, 58.3, 58.4, 58.5, 58.6, 58.7, 58.8, 58.9, 59.1, 59.2, 59.3, 59.4, 59.5, 59.6, 59.7, 59.8, 59.9, 60.1, 60.2, 60.3, 60.4, 60.5, 60.6, 60.7, 60.8, 60.9, 61.1, 61.2, 61.3, 61.4, 61.5, 61.6, 61.7, 61.8, 61.9, 62.1, 62.2, 62.3, 62.4, 62.5, 62.6, 62.7, 62.8, 62.9, 63.1, 63.2, 63.3, 63.4, 63.5, 63.6, 63.7, 63.8, 63.9, 64.1, 64.2, 64.3, 64.4, 64.5, 64.6, 64.7, 64.8, 64.9, 65.1, 65.2, 65.3, 65.4, 65.5, 65.6, 65.7, 65.8, 65.9, 66.1, 66.2, 66.3, 66.4, 66.5, 66.6, 66.7, 66.8, 66.9, 67.1, 67.2, 67.3, 67.4, 67.5, 67.6, 67.7, 67.8, 67.9, 68.1, 68.2, 68.3, 68.4, 68.5, 68.6, 68.7, 68.8, 68.9, 69.1, 69.2, 69.3, 69.4, 69.5, 69.6, 69.7, 69.8, 69.9, 70.1, 70.2, 70.3, 70.4, 70.5, 70.6, 70.7, 70.8, 70.9, 71.1, 71.2, 71.3, 71.4, 71.5, 71.6, 71.7, 71.8, 71.9, 72.1, 72.2, 72.3, 72.4, 72.5, 72.6, 72.7, 72.8, 72.9, 73.1, 73.2, 73.3, 73.4, 73.5, 73.6, 73.7, 73.8, 73.9, 74.1, 74.2, 74.3, 74.4, 74.5, 74.6, 74.7, 74.8, 74.9, 75.1, 75.2, 75.3, 75.4, 75.5, 75.6, 75.7, 75.8, 75.9, 76.1, 76.2, 76.3, 76.4, 76.5, 76.6, 76.7, 76.8, 76.9, 77.1, 77.2, 77.3, 77.4, 77.5, 77.6, 77.7, 77.8, 77.9, 78.1, 78.2, 78.3, 78.4, 78.5, 78.6, 78.7, 78.8, 78.9, 79.1, 79.2, 79.3, 79.4, 79.5, 79.6, 79.7, 79.8, 79.9, 80.1, 80.2, 80.3, 80.4, 80.5, 80.6, 80.7, 80.8, 80.9, 81.1, 81.2, 81.3, 81.4, 81.5, 81.6, 81.7, 81.8, 81.9, 82.1, 82.2, 82.3, 82.4, 82.5, 82.6, 82.7, 82.8, 82.9, 83.1, 83.2, 83.3, 83.4, 83.5, 83.6, 83.7, 83.8, 83.9, 84.1, 84.2, 84.3, 84.4, 84.5, 84.6, 84.7, 84.8, 84.9, 85.1, 85.2, 85.3, 85.4, 85.5, 85.6, 85.7, 85.8, 85.9, 86.1, 86.2, 86.3, 86.4, 86.5, 86.6, 86.7, 86.8, 86.9, 87.1, 87.2, 87.3, 87.4, 87.5, 87.6, 87.7, 87.8, 87.9, 88.1, 88.2, 88.3, 88.4, 88.5, 88.6, 88.7, 88.8, 88.9, 89.1, 89.2, 89.3, 89.4, 89.5, 89.6, 89.7, 89.8, 89.9, 90.1, 90.2, 90.3, 90.4, 90.5, 90.6, 90.7, 90.8, 90.9, 91.1, 91.2, 91.3, 91.4, 91.5, 91.6, 91.7, 91.8, 91.9, 92.1, 92.2, 92.3, 92.4, 92.5, 92.6, 92.7, 92.8, 92.9, 93.1, 93.2, 93.3, 93.4, 93.5, 93.6, 93.7, 93.8, 93.9, 94.1, 94.2, 94.3, 94.4, 94.5, 94.6, 94.7, 94.8, 94.9, 95.1, 95.2, 95.3, 95.4, 95.5, 95.6, 95.7, 95.8, 95.9, 96.1, 96.2, 96.3, 96.4, 96.5, 96.6, 96.7, 96.8, 96.9, 97.1, 97.2, 97.3, 97.4, 97.5, 97.6, 97.7, 97.8, 97.9, 98.1, 98.2, 98.3, 98.4, 98.5, 98.6, 98.7, 98.8, 98.9, 99.1, 99.2, 99.3, 99.4, 99.5, 99.6, 99.7, 99.8, 99.9

~~SECRET~~

~~SECRET~~

0984



0 9 8 5



0986





0987





0988

## DOCUMENT TO ROLL INDEX

| Frame Number | Classification Number | Date Period | Vol | Pt. | Title   | Security Classification | Remarks |
|--------------|-----------------------|-------------|-----|-----|---|-------------------------|---------|
| 6            | 1029150               | 44/05-44/07 |     |     | Neptune Arges #28-38 Intelligence Reports                     | U                       |         |
| 278          | 1029151               |             |     |     | European Theater Of Operations Inspection Of Soviet Airdromes | U                       |         |
| 319          | 1029152               |             |     |     | Plan For Retaliatory Gas Attack On Germany                    | U                       |         |
| 339          | 1029153               |             |     |     | Letter From American Embassy In Moscow                        | U                       |         |
| 346          | 1029154               | 44/09-44/09 |     |     | Frantic VII Mission Messages                                  | U                       |         |
| 480          | 1029155               | 45/06-45/07 |     |     | Denmark, SHAEF Mission Fortnightly Progress Report 19         | U                       |         |
| 516          | 1029156               | 44/07-44/08 |     |     | USSTAF Miscellaneous Messages                                 | U                       |         |
| 720          | 1029157               | 45/04-45/05 |     |     | Messages Concerning Evacuation Of Airbase At Poltava          | U                       |         |
| 728          | 1029158               | 45/03-45/03 |     |     | Messages Concerning Operation Frantic                         | U                       |         |
| 738          | 1029159               | 45/04-45/04 |     |     | " " " " " " " " " "   | U                       |         |
| 747          | 1029160               | 44/10-45/02 |     |     | Messages Concerning Liaison With                              |                         |         |

